

## Table of Contents

---

Affidavit of Application .....	1
Certificate of Applicant Status .....	3
Clearing and Grading Permit Application Worksheet .....	6
Vicinity Information .....	9
Narrative Description of Project .....	11
Site Plans.....	15
SEPA Checklist .....	18
Wetland Report .....	31



# Permit Application; Applicant Affidavit

Project Information			
PARCEL NUMER(S) 0425079017,0425079016		PERMIT NUMBER	
ADDRESS OF PROPOSED WORK <input type="checkbox"/> Address not yet assigned 8519 CARNATION DUVALL RD NE		RELATED PERMITS OR PRE-APP SR1449605 (Group B Well)	PROJECT VALUATION
SUMMARY OF PROPOSED WORK Connect three existing homes to a new well source. Project includes trenching of approximately 466 l.f. of 2" HOPE pipe and bore of approximately 180' of 2" HOPE pipe under Harris Creek to avoid impact to stream and stream buffer. See attached plan.			

Property Owner			
FULL NAME Julie Gaisford		PHONE NUMBER 206-963-4203	EMAIL ADDRESS GaisfordLaw@Centurytel.net
MAILING ADDRESS 8519 Carnation Duvall Rd NE		CITY Carnation	STATE WA
		ZIP CODE 98014	

Applicant <input checked="" type="radio"/> Same as Owner <input type="radio"/> Homeowner doing own work			
FULL NAME		PHONE NUMBER	EMAIL ADDRESS
MAILING ADDRESS		CITY	STATE   ZIP CODE
			WA

Contractor <input type="radio"/> Same as Applicant			
FULL NAME Brandon Simonds		PHONE NUMBER 206.786.5273 (M)	EMAIL ADDRESS BS@trenchlessconstruction.com
MAILING ADDRESS PO Box 3372		CITY Arlington	STATE   ZIP CODE WA   98223
CONTRACTOR NUMBER: TRENCCS013MW		EXPIRATION DATE: 11/2/2021	

# Permit Application; Applicant Affidavit, continued

I further certify that I am familiar with King County's Community Trails Preservation Program,

I am interested in granting a voluntary easement for a rural equestrian trail,

I am not interested in granting a voluntary easement for a rural equestrian trail.

Owner Affidavit In Lieu of Contractor Registration: required for a property owner doing all of the work under this permit themselves.

**D** I certify under penalty of perjury that I am the property owner and I am exempt from the requirements of the Contractor Registration laws, RCW 18.27, (Definitions, RCW 18.27.010 and Exemptions, RCW 18.27.090) and I will do all my own work.

### Critical Area Compliance:

The undersigned applicant declares: 1.) That the applicant is competent to be a witness herein; 2.) That the applicant is the applicant for the above project; 3.) That to the best of the applicant's knowledge, the critical areas on the development proposal site have not been illegally altered; and 4.) That the applicant has not previously been found in violation of critical areas regulations for any property in King County, or alternatively, that if there have been any violations, such violations have been cured to the satisfaction of King County.

I am submitting for a permit authorized by the international building, residential, fire, or mechanical codes and in anticipation of having it approved or approved with conditions, I have read the following statement and understand that failure to comply with all conditions once construction is begun may necessitate an immediate work stoppage until such time as compliance with the stipulated conditions is attained. I certify that I have made a diligent inquiry regarding the need for concurrent state or federal permits to engage in the work requested under this building permit, and no such permits are required or I will have obtained the required permits prior to issuance of this permit. I understand that the granting of this permit shall not be construed as satisfying the requirements of other applicable federal, state or local laws or regulations. In addition, I understand and agree that this permit does not authorize the violation of regulations. In addition, I understand and agree that this building permit does not authorize the violation of the Endangered Species Act as set forth at 16 U.S.C. § 1531-1543, including the prohibition on the "take" of threatened or endangered species. "Take" is defined at 16 U.S.C. § 1532(19). I fully understand that it is my sole responsibility to determine whether such "take" restrictions would be violated by work done pursuant to this permit, and I understand that I am precluded by Federal Law from undertaking work authorized by this permit if that work would violate the "take" restrictions set forth at 16 U.S.C. §1538, 50 C.F.R. §17.21, 50 C.F.R. §17.31, 50 C.F.R. §223, and 50 C.F.R. §224.

I certify under penalty of perjury and under the laws of the State of Washington, the foregoing is true and correct. I further certify that all easements, deed restrictions, or other encumbrances restricting the use of the property are shown on the site plans submitted with this application. We (I) have been given authorization from the property owner to obtain this permit.

I am the legal owner of this parcel, or have obtained authorization from the legal owner and agree that King County permitting staff may access the site for all project related purposes, including but not limited to necessary inspections

I accept financial responsibility for all fees associated with this permit or approval and will receive any applicable billings and/or refunds. As applicant, I will receive and be responsible for all correspondence related to this permit record.

APPLICANT SIGNATURE OR PRINTED NAME 	DATE 
--	---



# Applicant Status, Individual

PERMIT NUMBER	PERMIT NAME

## For Individual(s)

By signing this document, I certify that I am/we are an owner of the property(ies) affected by this permit.

Owner One				
FULL NAME	PHONE NUMBER	EMAIL ADDRESS		
Julie Gaisford	206-963-4203	gaisfordlaw@centurytel.net		
MAILING ADDRESS		CITY	STATE	ZIP CODE
8501 CARNATION DUVALL RD NE		Carnation	WA	98014
SIGNATURE OF OWNER ONE				

Owner Two				
D Same contact information as Owner One				
FULL NAME	PHONE NUMBER	EMAIL ADDRESS		
MAILING ADDRESS		CITY	STATE	ZIP CODE
SIGNATURE OF OWNER TWO		DATE		

Complete additional Certification of Applicant Status, Individual forms for any additional owners

Continued

# Applicant Status, Individual, continued

Applicant Information		<input type="checkbox"/> If other than property owners		
FULL NAME	PHONE NUMBER	EMAIL ADDRESS		
MAILING ADDRESS		CITY	STATE	ZIP CODE

I certify that I am the Applicant for this permit. As the Applicant, I am financially responsible for all fees, and I will receive any applicable refunds. I will remain the Applicant for as long as this permit is valid, unless I transfer my applicant status. The Applicant shall remain for the duration of this permit, unless the Applicant transfers its status in writing to the Department of Local Services, Permitting Division.

By signing as the Applicant or the Applicant's Agent, I certify under penalty of perjury under the laws of the State of Washington that the information provided above is true and correct.

I authorize Permitting to return plans directly to the engineer, architect or other consultant(s) for the limited purpose of making corrections as designated on the Authorized Consultant page.

SIGNATURE OR PRINTED NAME OF APPLICANT 	DATE 06/14/2021
--	--------------------

Authorized Consultant List,  
continued on next page

# Applicant Status, Individual, continued

## Authorized Consultants:

BUSINESS NAME		
Garrison Engineering		
CONTACT NAME	PHONE NUMBER	EMAIL ADDRESS
Carl Garrison	360-404-5058	carlg@gecorp.net
BUSINESS NAME		
MacWhinney Environmental Consulting		
CONTACT NAME	PHONE NUMBER	EMAIL ADDRESS
Betsy MacWhinney	206/794-2249	Betsy@MacWhinneyAssociates.com
BUSINESS NAME		
CONTACT NAME	PHONE NUMBER	EMAIL ADDRESS
-----	-----	-----
BUSINESS NAME		
CONTACT NAME	PHONE NUMBER	EMAIL ADDRESS
BUSINESS NAME		
CONTACT NAME	PHONE NUMBER	EMAIL ADDRESS
BUSINESS NAME		
CONTACT NAME	PHONE NUMBER	EMAIL ADDRESS
BUSINESS NAME		
CONTACT NAME	PHONE NUMBER	EMAIL ADDRESS
BUSINESS NAME		
CONTACT NAME	PHONE NUMBER	EMAIL ADDRESS
BUSINESS NAME		
CONTACT NAME	PHONE NUMBER	EMAIL ADDRESS



**King County**  
**Department of Permitting**  
**and Environmental Review**  
35030 SE Douglas St., Ste. 210  
Snoqualmie, WA 98065-9266  
**206-296-6600** TTY Relay: 711  
www.kingcounty.gov

**Clearing and Grading  
Permit Application  
Worksheet**

**PART I:** Project Information – To be filled out by applicant:

**Project Name:** Gaisford Well

**Street Address:** 8519 Carnation Duvall Road NE

**Pre-Application File No.:** \_\_\_\_\_

**Clearing/Grading Permit Application No.:** \_\_\_\_\_

**Other Related Application/Permit Nos.:** \_\_\_\_\_

**Property Information:**

Parcel No(s) : 0425079017, 0425079016

Zoning: A35

Community Plan: Snoqualmie Valley Lot size: 10.2, 0.85

Thomas Guide Page: 539 Other: \_\_\_\_\_

**Project Description:**

Connect three existing homes to a new well source. Project includes trenching of approximately 466 l.f. of 2" HDPE pipe and bore of approximately 180' of 2" HDPE pipe under Harris Creek to avoid impact to stream and stream buffer. See attached plan.

**Project Area & Volumes:**

Total Area Cleared/Graded:	_____ ac.	Volume of Excavation:	_____ c.y.
Total New Impervious Surface:	<u>0</u> s.f.	Volume of Fill (Exported):	<u>0</u> c.y.
Total New Pervious Surface:	<u>0</u> s.f.	Volume of Fill (Imported):	<u>20</u> c.y.

**Applicant:** Julie Gaisford  
8519 Carnation Duvall Rd NE  
Carnation, WA 98014

Phone No.: 206-963-4203

E-Mail: gaisfordlaw@centurytel.net

**Owner:** same as above  
**Address:** \_\_\_\_\_  
 \_\_\_\_\_  
**Phone No:** \_\_\_\_\_  
**E-Mail:** \_\_\_\_\_

**Agent:** \_\_\_\_\_  
**Address:** \_\_\_\_\_  
 \_\_\_\_\_  
**Phone No:** \_\_\_\_\_  
**E-Mail:** \_\_\_\_\_

**PART II:** Submittal Requirements – To be filled out by DPER staff:

Permit Type: \_\_\_\_\_ DPER Staff Assigned: \_\_\_\_\_

Submittal Requirements:

- \_\_\_\_\_ Affidavit for Application Form
- \_\_\_\_\_ Clearing / Grading Plan (Scaled & Dimensioned)
- \_\_\_\_\_ Temporary Erosion Sedimentation Control Plan (TESC)
- \_\_\_\_\_ Drainage Plan and Calculations
- \_\_\_\_\_ Grading Earthwork Calculations
- \_\_\_\_\_ Environmental Checklist including Green House Gas Emission Worksheet
- \_\_\_\_\_ Environmental Determination
- \_\_\_\_\_ Critical Area Plan & Studies
- \_\_\_\_\_ Soil Amendment Plan
- \_\_\_\_\_ Fee Application Worksheet
- \_\_\_\_\_ Other: \_\_\_\_\_
- \_\_\_\_\_ Other: \_\_\_\_\_

**Part III:** Property Information – To be filled out by DPER staff:

Have critical area reports been prepared for this or adjoining properties?  yes  no  
 Has a critical area notice on title been recorded on this or adjoining property?  yes  no

Critical Area	Contains		Abuts		Comments
	Yes	No	Yes	No	
Wetlands					
Aquatic Areas					
Steep Slope					
Landslide Hazard					
Erosion Hazard					
Seismic Hazard					
Coalmine Hazard					
Floodplain					
Critical Aquifer Recharge					
Channel Migration					
Wildlife Habitat					
Wildlife Corridor					



**Part IV:** Additional Permits Required for Proposal – To be filled out by DPER staff

Types	Required Y/N	Received Y/N	Comments
Building Permit			
Demolition Permit			
Forest Practice Permit			
ROW Use Permit			
Critical Area Exception			
Shorelines SSDP or Exemption			
Franchise ROW Use Permit			
USACE Permit			
WSDOT Access Permit			
HPA from WDFW			
NPDES			
JARPA			
Other?			
Other?			

**Part V:** Documents Routed for Review:

	Required Y/N	To:	Comments
Clearing / Grading			
Drainage			
Traffic			
Wetlands / Streams			
Geotechnical			
Flood Hazard			
Planning			
Building / Structural			
Other?			
Other?			

Project: Gaisford Well  
Applicant: Julie Gaisford  
E-mail: [gaisfordlaw@centurytel.net](mailto:gaisfordlaw@centurytel.net)

**Legal Description(s):**

**0425079017:** POR OF SE 1/4 - BEG INTSN OF WLY R/W MGN OF ST HWY NO 15-B & THE N LN OF SE 1/4 OF SE 1/4 TH WLY ALG SD N LN 680 FT TH N 00-12-00 W TAP ON SLY R/W MGN OF ST HWY NO 15-B TH SELY ALG SD R/W MGN TO POB LESS BEG ON E LN OF SE 1/4 1757.01 FT N OF SE COR OF SEC TH W 116.34 FT TO WLY MGN OF HWY & TPOB TH N 39-04-26 W ALG SAID WLY MARGIN 242.80 FEET TH S 36-42-26 W 176.76 FT TH S 23-55-27 W 40.80 FT TH S 64-08-48 E 198.10 FT TH N 51-24-27 E 123.77 FT TO TPOB LESS ELY 50 FT FOR PUGET SOUND POWER & LIGHT CO R/W - CLASSIFIED AS OPEN SPACE "FARM & AGRICULTURAL" PURSUANT TO RCW 84.34

**0425079016:** BAAP ON E LN OF SE 1/4 1757.01 FT N OF SE COR OF SEC TH W 116.34 FT TO WLY MGN OF HWY & TPOB TH N 39-04-26 W ALG SD WLY MGN 242.80 FT TH S 36-42-26 W 176.76 FT TH S 23-55-27 W 40.80 FT TH S 64-08-48 E 198.10 FT TH N 51-24-27 E 123.77 FT TO TPOB

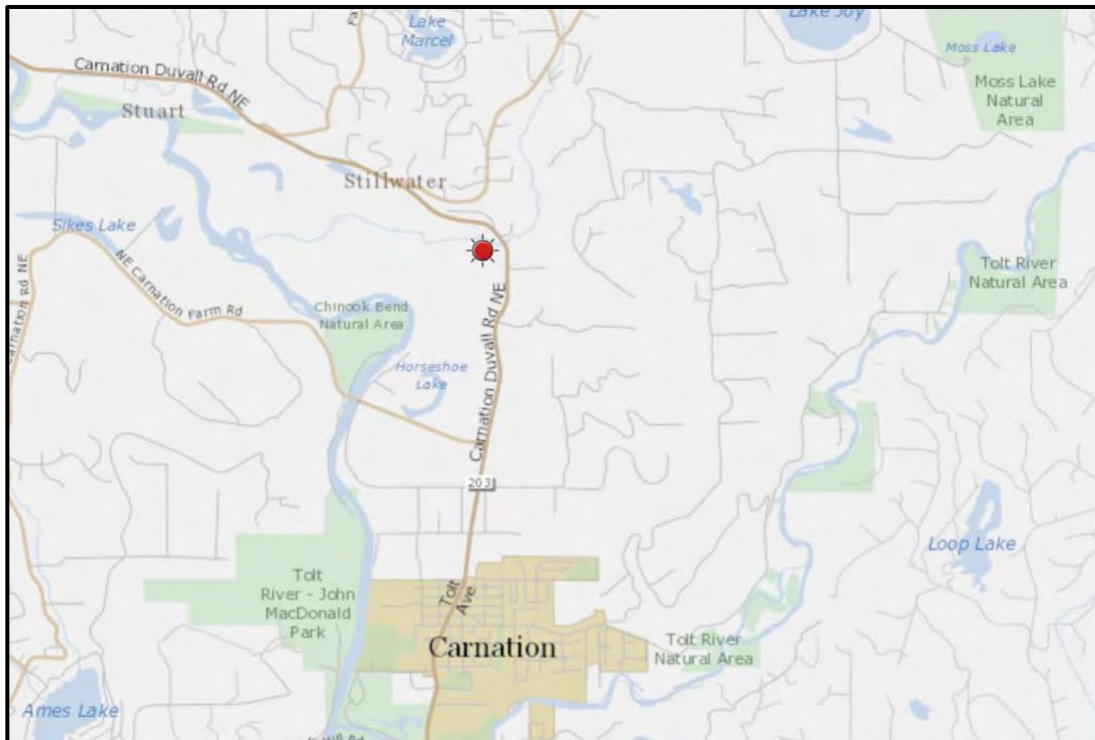

Figure 1. Vicinity Map.

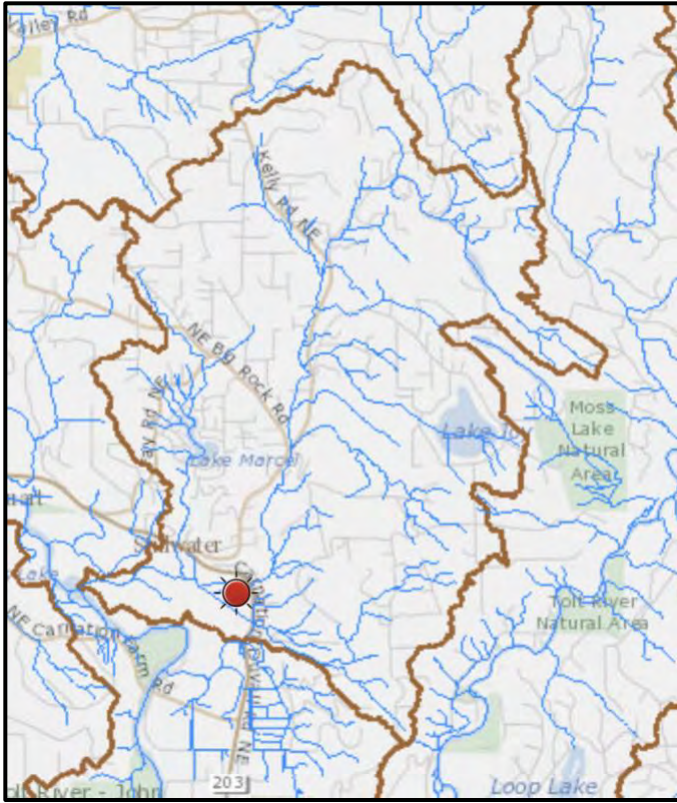

Figure 2. Drainage Basin Map.

## *CLEARING & GRADING PERMIT, GAISFORD WATER LINE*

This brief document provides information regarding the purpose, need, and details of the above-referenced project. This information was prepared by Betsy MacWhinney, MacWhinney Environmental Consulting based on information provided by the Julie Gaisford, the landowner, and Carl Garrison, PE, Garrison Engineering.

### **Project Description**

The Gaisford farm consists of four parcels that have been farmed for generations, beginning in the early 1900's. The farm is situated entirely on the west side of State Route (SR) 203. Two of the parcels are developed with houses. Parcel 042507-9017 has two homes, and parcel 042507-9016 has one home. All three homes have been served by a documented surface water right from a property east of SR 203, not owned by the farm. At least since 1935, surface water was provided to all three homes including parcel -9016, north of Harris Creek. The surface water failed several years ago, and at that time, existing water lines were connected to an old well that does not meet the Health Code due to the presence of farm buildings within the 100-foot well radius. In order to remedy this situation, the landowner recently applied for, and received a permit for a new from the King County Health Department (SR1449605). Of significance to this application is that parcel 9016 is on the north side of Harris Creek; the other two homes are on the south side of Harris Creek.

The new well will be drilled on parcel -9017 and connected to the existing waterline infrastructure to serve the two houses on parcel -9017. This connection requires installation of approximately 55 feet of new waterline.

The current connection to the house on parcel -9016 is a line suspended over Harris Creek. That line has been suspended in this location for more than 60 years. Currently it is attached to the State Bridge. This line was installed originally by prior owners without permission or permits and was in place in 1997 when the current owners purchased the property. In order to deliver safe water to the house (parcel 9016) without harming Harris Creek or the vegetated portion of the regulatory buffer, the applicant proposes to bore under Harris Creek at a depth of 15 feet. KCC 21A.24.045 D 60 lists criteria for a waterline within a critical area or buffer. These criteria are provided in Table 1.

Table 1. Criteria for Utility Placement

Criteria	Comment
a. there is no alternative location with less adverse impact on the critical area or the critical area buffer;	Alternatives were evaluated and determined to be impractical.
b. the residential utility service distribution lines meet all of the following, to the maximum extent practical:	
(1) are not located over habitat used for salmonid rearing or spawning or by a species listed as endangered or threatened by the state or federal government unless the department determines that there is no other feasible crossing site;	Utility line will be under stream and will not affect salmonid rearing areas.
(2) not located over a type S aquatic area;	Criterion met. Trench will be under stream.
(3) paralleling the channel or following a down-valley route near the channel is avoided;	Criterion met.
(4) the width of clearing is minimized;	No clearing of native vegetation will be necessary.
(5) the removal of trees greater than twelve inches diameter at breast height is minimized;	No trees will be removed.
(6) an additional, contiguous and undisturbed critical area buffer, equal in area to the disturbed critical area buffer area is provided to protect the critical area;	n/a
(7) access for maintenance is at limited access points into the critical area buffer.	Criterion met.
(8) the construction occurs during approved periods for instream work;	No instream work proposed.
(9) bored, drilled, or other trenchless crossing is encouraged, and shall be laterally constructed at least four feet below the maximum depth of scour for the base flood; and	Lateral bore will be 15-feet below channel.
(10) open trenching across Type O or Type N aquatic areas is only used during low flow periods or only within aquatic areas when they are dry.	N/A

## Alternatives Analysis

Three alternatives were considered. Each is described below.

1. Obtain water from Water District 119 from the east side of SR 203, within the State right of way. This option was evaluated and is cost prohibitive. Estimated costs exceed \$325,000 without administrative costs, costs of state supervision and the cost of running a line across Harris Creek on the east side of SR 203. It would require more than 900 feet of pipeline installation and associated impacts. It would also be necessary to cross Harris Creek for the water district to run its line to serve the two homes on parcel 9017. This alternative would also require boring under the state highway to service the homes at expense and inconvenience to commuting traffic. Due to the cost and considerable social and environmental impact, this alternative was eliminated.
2. Obtain a permission from WSDOT to attach the current line to the bridge over Harris Creek. WSDOT has plans to replace the bridge and which will disrupt water service to 9017. The

Water District informed the owner that WSDOT will not allow a water line suspended over the Creek. Therefore, this alternative was eliminated as not viable.

3. Bore under Harris Creek. Entrance and exit to and from the bore tunnel will be within existing disturbed lawn areas. This alternative was determined to be the least impactful, practical solution. A depth of 15 feet has been determined to be more than adequate to protect Harris Creek from potential impact.

## Impacts to Critical Areas

The general area of the new waterline contains critical areas, including a wetland and Harris Creek. Each critical area and potential impacts resulting from the proposal are discussed below. These areas are shown on the accompanying site plan.

### Wetland

A Critical Areas Designation was approved by King County (CADS20-0348). Based on this partial review of the site, one Category III wetland with 60-foot buffers is present. The wetland is dominated by reed canarygrass (*Phalaris arundinacea*).

No activity is proposed within the wetland. The well and a portion of the new well line is within the 60-foot wetland buffer. However, this area has been disturbed and developed with farm buildings and adjacent maintained areas for more than a century. Upon completion of the project, the area is anticipated to be similar in character and function to the existing buffer area. A photograph of the impact area is provided in Figure 1. The water line will be placed immediately adjacent to the left (north) of the existing road in an area that is vegetated with domestic grasses and pockets of Himalayan blackberry (*Rubus armeniacus*). Upon completion of pipe installation, the area will be replanted with grass.



Figure 1. Vicinity of well and water line.

## Harris Creek

Harris Creek is a Type F stream that enters the Snoqualmie River approximately 1.5 miles west of the subject property. This fish-bearing stream has a forested riparian corridor associated with it. A photograph of the area is provided in Figure 2. As shown, the area is vegetated with red alder (*Alnus rubra*), with an understory of Japanese knotweed (*Polygonum cuspidatum*). The stream provides excellent habitat for salmonids, with overhanging vegetation, gravel substrate.

The waterline in this area will be installed by boring below the bottom of the creek bed. The pipeline will begin in an area of existing lawn on the north side of Harris Creek. The temporary surface impact will be an approximately 42" wide by 8' long and 4' deep. The bore will originate from the north side of the creek in an existing graveled area next to the barns in a bore pit that is 42" wide



Figure 2. Harris Creek.

## Regulatory Framework

The following permits have been or will be applied for:

1. King County Clearing and Grading Permit
2. King County Health Department Permit (Approved)
3. SEPA Determination
4. Hydraulic Project Approval. **Note:** This cannot be applied for until a SEPA determination has been issued by King County.

# BLACKACRE GROUP B WATER SYSTEM

## CARNATION, WASHINGTON

### PROJECT REFERENCES:

**REVIEW AGENT**

WASHINGTON STATE DEPARTMENT OF HEALTH

**OWNER**

JULIE GAISFORD  
PO BOX 54  
8519 CARNATION-DUVAL RD  
CARNATION, WA 98014  
206-963-4203  
gaisfordlaw@centurytel.net

**SATELLITE MANAGEMENT AGENCY**

PENDING

**ENGINEER OF RECORD**

GARRISON ENGINEERING  
CARL GARRISON, PE  
PH: 360-404-5058  
carlg@gecorp.net

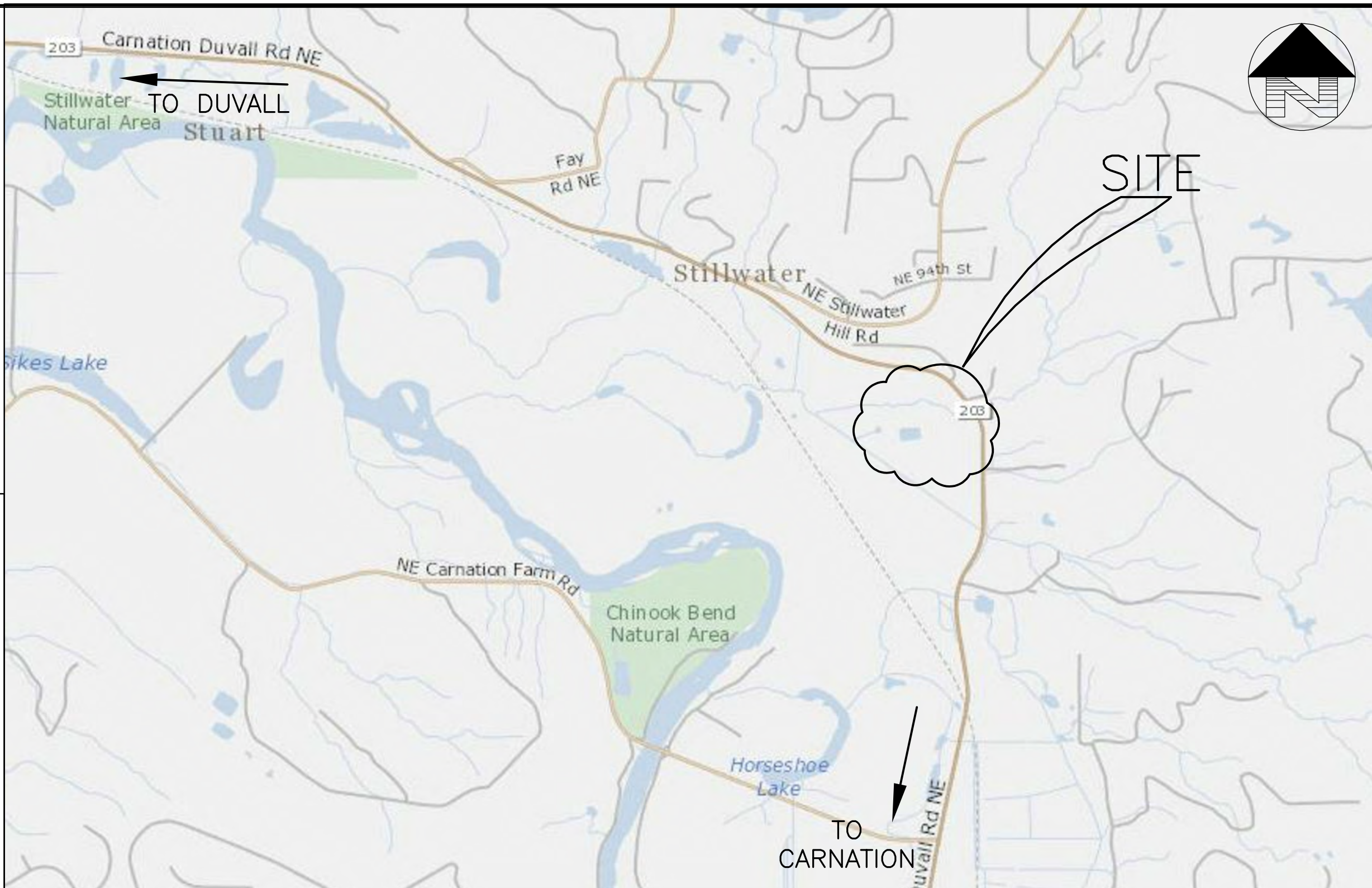

KING C. PARCEL VIEWER - VICINITY MAP  
NTS

**GENERAL NOTES AND SPECIFICATIONS**

**GENERAL REQUIREMENTS:** ALL PROJECT RELATED GENERAL REQUIREMENTS INCLUDING BIDDING, BONDING, INSURANCES, CONTRACTING AWARDS, WORK SCOPE, CONTROL OF WORK, CONTROL OF MATERIAL, LEGAL ISSUES, PROSECUTION AND PROGRESS, AND MEASUREMENT AND PAYMENT SHALL BE PER THE OWNER OR THEIR CONTRACTING OFFICER. THE CONTRACTOR SHALL BE RESPONSIBLE FOR UNDERSTANDING ALL GENERAL REQUIREMENTS PRIOR TO BIDDING OR PROSECUTION OF THE WORK. DOCUMENTS SUPPLIED BY THE CONTRACTING OFFICER IN THESE REGARDS, IF ANY, SHALL TAKE PRECEDENCE OVER ANY OTHER WRITTEN OR IMPLIED GENERAL REQUIREMENTS.

**CODES AND STANDARDS:** ALL WORK PERTAINING TO THE CONSTRUCTION OF THE FACILITIES SHOWN HEREIN SHALL BE IN ACCORDANCE WITH THESE PLANS AND SPECIFICATIONS, AND THE REVIEWING AGENCY REGULATIONS AND SPECIFICATIONS. THE TECHNICAL PROVISIONS (BUT NOT GENERAL REQUIREMENTS, AS LISTED ABOVE) OF WASHINGTON STATE DEPARTMENT OF TRANSPORTATION (WSDOT), UNIFORM BUILDING CODE (UBC), AND AMERICAN WATER WORKS ASSOCIATION (AWWA) SPECIFICATIONS (LATEST EDITIONS) ARE ALSO INCORPORATED INTO THESE SPECIFICATIONS AND PLANS BY REFERENCE. IN THE EVENT OF CONFLICTS, THE MORE STRINGENT STANDARDS SHALL GOVERN.

**PERMITS:** THE CONTRACTOR SHALL BE RESPONSIBLE FOR APPLYING, PAYING, AND OBTAINING ALL PERMITS UNLESS OTHERWISE NOTED IN THE BID DOCUMENTS, OR UNLESS OTHERWISE INSTRUCTED BY THE OWNER. CONTRACTOR SHALL BE RESPONSIBLE FOR COMPLYING WITH ALL PERMIT REQUIREMENTS.

**EXISTING UTILITIES:** THE CONTRACTOR SHALL BE RESPONSIBLE FOR NOTIFICATION OF ALL UTILITY COMPANIES WHICH MAY HAVE UNDERGROUND UTILITIES IN THE WORK AREA. CONTRACTOR SHALL, AT A MINIMUM, USE THE ONE CALL LOCATE SERVICE AT (800) 424-5555, TO VERIFY ALL UNDERGROUND UTILITY LOCATIONS WHICH ARE INVOLVED, OR WHICH MAY CONFLICT WITH THE WORK HEREIN, AND SHALL BE RESPONSIBLE FOR REPAIR OF ANY KNOWN UTILITIES WHICH ARE DAMAGED AS A RESULT OF THIS WORK.

**UNFORESEEN PHYSICAL CONDITIONS:** IF THE CONTRACTOR ENCOUNTERS CONDITIONS AT THE SITE WHICH ARE SUBSURFACE OR OTHERWISE CONCEALED, UNKNOWN OR UNUSUAL IN NATURE, THEN IT IS THE CONTRACTOR'S RESPONSIBILITY TO NOTIFY THE OWNER IMMEDIATELY. THE CONTRACTOR SHALL NOT PROCEED WITH FURTHER CONSTRUCTION UNTIL APPROVED BY THE OWNER.

**CLEAN UP:** THE CONTRACTOR SHALL CLEAN ALL AREAS DISTURBED BY CONSTRUCTION TO A NEAT AND TIDY APPEARANCE. ALL DIRT, MUD, GARBAGE, AND DEBRIS SHALL BE REMOVED FROM SITE, AND ALL NEW OR EXISTING PAVED OR GRAVELED SURFACES DIRTIED BY CONSTRUCTION SHALL BE WASHED CLEAN. PIPING SYSTEMS AND CATCH BASINS FILLED 5% OR MORE WITH DIRT, SILT, OR MUD SHALL BE CLEANED AT THE CONTRACTOR'S EXPENSE.

**WORKING HOURS:** UNLESS OTHERWISE APPROVED BY THE OWNER, THE CONTRACTOR SHALL LIMIT ALL WORKING HOURS TO DAYLIGHT HOURS, BETWEEN 7:00 AM AND 5:00 P.M., MONDAY THROUGH FRIDAY. THE CONTRACTOR SHALL NOT WORK ON NATIONALLY RECOGNIZED HOLIDAYS, UNLESS PRIOR APPROVAL BY THE OWNER HAS BEEN GRANTED.

**DEMOLITION/SALVAGE:** IN GENERAL, ALL ITEMS TO BE DEMOLISHED UNDER THIS PROJECT SHALL BE REMOVED FROM SITE BY THE CONTRACTOR AT THE CONTRACTOR'S EXPENSE. UNDERGROUND PIPE THAT WILL BE ABANDONED IN PLACE SHALL BE EXEMPT FROM THIS PARAGRAPH. THE OWNER RESERVES THE RIGHT TO RECLAIM ANY DEMOLISHED OR REMOVED ITEMS. IF THE CONTRACTOR EXPENDS EXTRA EFFORT IN SUCH SALVAGE FOR THE CONTRACTING OFFICER, THE CONTRACTOR SHALL NEGOTIATE WITH THE CONTRACTING OFFICER A CHANGE ORDER TO COMPENSATE THE CONTRACTOR FOR THE EXTRA COSTS INVOLVED IN THE SALVAGE. THE CONTRACTOR'S PROPOSED ON-SITE LOCATION(S) OF DEMOLISHED MATERIALS SHALL BE CLEARED WITH THE CONTRACTING OFFICER PRIOR TO ANY DEMOLITION OR STOCKPIPING.

**REQUESTS FOR INFORMATION (RFI):** SHOULD ANY ITEM IN THE PLANS REQUIRE CLARIFICATION OR ADDITIONAL INFORMATION; OR IF THE CONTRACTOR DISCOVERS AN ERROR OR OMISSION IN THE PLANS, THE CONTRACTOR SHALL IMMEDIATELY NOTIFY THE CONTRACTING OFFICER. THE CONTRACTOR MAY BE REQUIRED TO PUT SUCH NOTIFICATION IN WRITING IN THE FORM OF AN RFI, WHICH SHALL BE EMAILED TO THE ENGINEER.

**GRUBBING AND CLEARING:** THE CONTRACTOR SHALL REMOVE ALL VEGETATION AND ROOT SYSTEMS FROM AREAS OF EXCAVATION OR FILL (TRENCHES) AS NECESSARY. THE CONTRACTOR SHALL HAUL VEGETATION AND WOOD WASTE OFF SITE TO A LEGAL DUMPING OR SLASH BURNING AREA AT THE EXPENSE OF THE CONTRACTOR.

**ON-SITE CONSTRUCTION SURVEYING:** THE OWNER OR ENGINEER SHALL APPROVE OF ALL VALVE AND PIPELINE LOCATIONS PRIOR TO THE START OF WORK. THE CONTRACTOR SHALL BE RESPONSIBLE FOR OBTAINING APPROVAL FROM THE OWNER PRIOR TO THE START OF WORK.

**DAMAGED ITEMS BY CONTRACTOR:** ANY DAMAGED CONCRETE, ASPHALT, STRUCTURES, ETC. SHALL BE REMOVED AND REPLACED AT THE CONTRACTOR'S EXPENSE. SUCH REMOVAL/REPLACEMENT ACTIVITIES SHALL BE COORDINATED WITH THE OWNER PRIOR TO WORK BEING PERFORMED. PAINT OR OTHER COATING SYSTEMS DAMAGED BY THE CONTRACTOR SHALL BE REPAIRED WITH SIMILAR COATING SYSTEMS AT THE CONTRACTOR'S EXPENSE. DAMAGED FENCES, DRIVEWAYS, TREES, FLOWERS AND SHRUBS SHALL BE REPLACED WITH SIMILAR PLANTS APPROVED BY THE OWNER.

**SITE RESTORATION:** ALL DENUDED SOIL AREAS SHALL BE HYDROSEEDED BY THE CONTRACTOR WITH A SEED/BINDER/FERTILIZER MIX SUITABLE FOR THE PARTICULAR APPLICATION, AND APPROVED BY THE OWNER.

**WATER**

**STANDARD SPECIFICATIONS:** STANDARD SPECIFICATIONS TO BE THE MOST CURRENT VERSION OF THE WASHINGTON STATE DEPARTMENT OF TRANSPORTATION STANDARD SPECIFICATIONS FOR ROAD, BRIDGE, AND MUNICIPAL CONSTRUCTION, AND AWWA CURRENT STANDARDS.

**CONTRACTORS:** CONTRACTORS SHALL NOTIFY AND COORDINATE WITH THE OWNER PRIOR TO CONSTRUCTION.

**SUBMITTALS:** ALL EQUIPMENT, FITTINGS, AND PIPE SUBMITTALS TO BE APPROVED BY THE ENGINEER PRIOR TO CONSTRUCTION.

**MAIN PIPELINE MATERIALS:** USE DR-11 HDPE PIPE FOR DISTRIBUTION. CLASS 200 POLY MAY BE SUBSTITUTED.

**VALVES:** ALL WATER MAIN GATE VALVES SHALL BE AWWA C500, RESILIENT WEDGE TYPE, PER STANDARD SPECIFICATIONS CH. 9-30.

**ALL WATER MAIN INSTALLATIONS REQUIRE A 36" MINIMUM COVER AND MAXIMUM OF 48" TRENCH DEPTH BELOW PROPOSED FINISHED GRADE.**

**MARKING TAPE:** MARKING TAPE SHALL BE PLACED 12" BELOW GRADE OVER ALL MAINS AND POLYETHYLENE SERVICES. THE TAPE SHALL BE OF THE DETECTABLE TYPE WITH METALIC FOIL LAMINATE AND PLASTIC JACKET, 6" WIDE, BLUE COLOR WITH WORDING "WATER LINE".

**LOCATE WIRE:** COPPERHEAD HIGH STRENGTH TRACER WIRE, PART # 1230B-HS, OR EQUAL.

**MINIMUM SPACING:** FOR SEPTIC & SEWER PIPES, MAINTAIN A MINIMUM OF 18 INCH VERTICAL SEPARATION AND 10-FOOT HORIZONTAL SEPARATION BETWEEN WATERLINE AND NON-POTABLE LINES. MINIMUM OF 1-FOOT SEPARATION BETWEEN WATERLINE AND ALL OTHER UTILITIES.

**TRENCHING, BEDDING AND BACKFILL:** USE MATERIALS AND METHODS PER TRENCH DETAILS.

**PRESSURE TEST NEW PIPELINE, INCLUDING SERVICE LINES AT 130 PSI FOR 2 HOURS AND AS PER WSDOT STANDARDS; ENGINEER TO WITNESS PRESSURE TEST.**

**TEST DATE \_\_\_\_\_ TEST PRESSURE \_\_\_\_\_**  
**TIME START \_\_\_\_\_ TIME END \_\_\_\_\_**  
**PRESSURE DROP \_\_\_\_\_ MAKE UP WATER \_\_\_\_\_**

**DISINFECTION:** ALL PERMANENT EQUIPMENT AND MATERIALS USED IN THE WELL SHALL BE CHLORINATED PER WSDOT AND AWWA STANDARDS (ANSI/AWWA C654-13) FOR DISINFECTION OF WELLS. ALL EQUIPMENT INSTALLED IN THE WELL SHALL BE CHLORINATED PRIOR TO INSTALLATION. ALL EQUIPMENT SURFACES SHALL BE SPRAYED WITH A SOLUTION HAVING A CHLORINE RESIDUAL OF NOT LESS THAN 200 mg/L.

**AFTER PERMANENT EQUIPMENT IS INSTALLED, THE WELL SHALL BE DISINFECTED BY CIRCULATING CHLORINATED WATER WITHIN THE WELL CASING AND PUMP COLUMN, AND PUMPING THE WELL TO WASTE TO REMOVE THE CHLORINATED WATER. THIS SHALL BE DONE USING THE FOLLOWING PROCEDURE:**

1. THE WATER IN THE CASING SHALL BE TREATED WITH AN AVERAGE 100 mg/L JET-LUBE STERILE SOLUTION THROUGH THE ENTIRE VOLUME OF WATER IN THE CASING. SEE DOSAGE CHART ON PRODUCT CONTAINER. THE DOSED WATER SHALL BE ALLOWED TO REST IN THE CASING AND ANY SYSTEM PIPING FOR 4-24 HOURS.
2. TO CIRCULATE THE TREATED WATER, A PRESSURE TIGHT CONNECTION SHALL FIRST BE MADE FROM THE PUMP TO THE CASING VENT. THE PUMP SHALL THEN BE OPERATED AGAINST A THROTTLED DISCHARGE VALVE TO RETURN A FLOW OF WATER DOWN THE WELL CASING WHILE THE REST OF THE PUMPED WATER IS DISCHARGED TO WASTE. IN LOW-PRODUCING WELLS, THE RATE OF RETURN NEED NOT EXCEED ONE HALF THE MAXIMUM RATE OF PRODUCTION OF THE WELL. TAKE CARE THAT THE DISCHARGE VALVE NOT BE THROTTLED TO THE EXTENT THAT THE PRESSURE DEVELOPED WILL DAMAGE EQUIPMENT OR PIPE-RESTRAINING TIES.
3. WHEN PURGING THE SYSTEM OF CHLORINE RESIDUAL, THE DISCHARGE WATER SHALL BE DE-CHLORINATED USING VITA-D-CHLOR. DO NOT DISCHARGE DIRECTLY TO ANY WATER WAY. USE A 55 GALLON DRUM WITH ADEQUATE VITA-D-CHLOR PRIOR TO NEUTRALIZE ANY CHLORINE PRIOR TO DISCHARGE. THE WATER ENTERING THE 55 GALLON DRUM SHALL BE TESTED PERIODICALLY FOR FREE CHLORINE. WHEN ZERO CHLORINE RESIDUAL IS MEASURED, THE WELL SHALL CONTINUE TO BE PUMPED TO WASTE FOR AT LEAST 15 MINUTES. THE WELL SHALL THEN BE SAMPLED FOR BACTERIOLOGICAL EVALUATION AND THE RESULTS SENT TO GARRISON ENGINEERING AND THE OWNER.

**UNDERGROUND PIPING:** ALL NEW WATER MAINS AND SERVICES, REPAIRED PORTIONS, AND EXTENSIONS TO EXISTING MAINS SHALL BE CHLORINATED PER WSDOT AND AWWA STANDARDS (ANSI/AWWA C651-05) FOR DISINFECTING WATER MAINS. PLACE 1 OUNCE OF HI-TEST HYPO-CHLORITE GRANULES IN WATERLINE FOR EVERY 100 FEET OF 1/2 INCH PIPE. FLUSH AFTER LETTING SOAK A MINIMUM OF 24-HOURS AND PER WSDOT AND AWWA STANDARDS. USE A 0-200 PPM HACH CHLORINE TEST KIT. CONTRACTOR TO TEST THE DISINFECTED PIPE AT START OF 24 HOUR SOAK AND AGAIN AT THE END. TEST THE CONCENTRATION (PPM) OF CHLORINE AND PROVIDE START AND END CONCENTRATIONS TO THE ENGINEER. THE TARGET RANGE IS >50 PPM AT THE BEGINNING AND >20 PPM AT THE END OF THE SOAK.

**ABOVE GROUND PIPING AND REPAIRS:** ALL NEW PIPE OR REPAIRED PORTIONS SHALL BE CHLORINATED PER WSDOT AND AWWA STANDARDS (ANSI/AWWA C651-05) FOR DISINFECTING WATER MAINS. THE NEW PIPE, FITTINGS, AND VALVE(S) REQUIRED FOR CONNECTION MAY BE SPRAY-DISINFECTED OR SWABBED WITH A MINIMUM 1 PERCENT SOLUTION OF CHLORINE JUST PRIOR TO BEING INSTALLED AND FLUSHED.

**DECHLORINATION:** USE ASCORBIC ACID (VITAMIN C) TO DECHLORINATE OR NEUTRALIZE THE HEAVILY CHLORINATED WATER. DURING DECHLORINATION, MAINTAIN A RATIO OF A MINIMUM OF 2.5 POUNDS OF ASCORBIC ACID PER ONE POUND OF CHLORINE IN SOLUTION TO NEUTRALIZE THE HEAVILY CHLORINATED WATER PRIOR TO DISCHARGING TO AN OPEN DITCH. WHEN FLUSHING CHLORINATED WATER, DO NOT ALLOW ANY UN-NEUTRALIZED CHLORINATED WATER TO FLOW INTO ANY CREEK OR SURROUNDING CATCH BASIN. CONTRACTOR TO USE A 0-3.5 PPM HACH CHLORINE TEST KIT, CN-68F OR EQUAL, TO CONFIRM THAT NO FREE CHLORINE IS PRESENT AFTER DECHLORINATION.

**INSPECTION:** CONTRACTOR SHALL NOTIFY AND COORDINATE WITH THE OWNER PRIOR TO ANY EXCAVATION, INSTALLATION, OR CONNECTION TO EXISTING FACILITIES. THE ENGINEER SHALL INSPECT ALL PIPE PRIOR TO BURIAL. FAILURE TO COMPLY WILL RESULT IN RE-EXCAVATION AND BEDDING OF THE PIPE AT THE EXPENSE OF THE CONTRACTOR.

**BACTERIOLOGICAL TESTS:** TEST RESULTS CERTIFYING THE WATER SAMPLED FROM EACH LEG OR SECTION OF THE DISINFECTED WATER MAIN TO BE FREE OF COLORFUL BACTERIA CONTAMINATION AND TO HAVE A BACTERIOLOGIC WATER QUALITY LEVEL THAT MEETS THE W.S.D.O.H. SEND BACTERIOLOGICAL RESULTS TO GARRISON ENGINEERING. APPROVAL SHALL BE OBTAINED BEFORE FINAL CONNECTION. COORDINATE ALL SHUTDOWN, FLUSHING, AND HEALTH SAMPLES WITH THE OWNER.

**TESC**

**GENERAL:** IN ALL AREAS OUTSIDE OF THE ROAD EDGES, ANY DITCH WORK, AND ANY ROAD EDGE AREAS THAT ARE LEFT UNCOVERED FOR MORE THAN TWO DAYS, THE FOLLOWING TESC MEASURES WILL BE APPLIED:

**ALL SHALL BE IN ACCORDANCE WITH THE LATEST VERSION OF THE WASHINGTON STATE DEPARTMENT OF ECOLOGY STORM WATER MANAGEMENT MANUAL FOR WESTERN WASHINGTON.**

**APPROVAL OF THIS TEMPORARY EROSION AND SEDIMENTATION CONTROL (TESC) PLAN DOES NOT CONSTITUTE AN APPROVAL OF PERMANENT ROAD OR DRAINAGE DESIGN (E.G. SIZE AND LOCATION OF ROADS, PIPES, RESTRICTORS, CHANNELS, RETENTION FACILITIES, UTILITIES, ETC.)**

**THE IMPLEMENTATION OF THESE TESC PLANS AND THE CONSTRUCTION, MAINTENANCE, REPLACEMENT, AND UPGRADING OF THESE TESC FACILITIES IS THE RESPONSIBILITY OF THE CONTRACTOR UNTIL ALL CONSTRUCTION IS APPROVED.**

**THE TESC FACILITIES SHOWN ON THIS PLAN MUST BE CONSTRUCTED PRIOR TO OR IN CONJUNCTION WITH ALL CLEARING AND GRADING SO AS TO ENSURE THAT THE TRANSPORT OF SEDIMENT TO SURFACE WATERS, DRAINAGE SYSTEMS, AND ADJACENT PROPERTIES IS MINIMIZED.**

**THE TESC FACILITIES SHOWN ON THIS PLAN ARE THE MINIMUM REQUIREMENTS FOR ANTICIPATED SITE CONDITIONS. DURING THE CONSTRUCTION PERIOD, THESE TESC FACILITIES SHALL BE UPGRADED AS NEEDED FOR UNEXPECTED STORM EVENTS AND MODIFIED TO ACCOUNT FOR CHANGING SITE CONDITIONS (E.G. ADDITIONAL CATCH BASIN FILTER FABRIC, RELOCATION OF STRAW WATTLES, AND SILT FENCES AS APPLICABLE).**

**THE TESC FACILITIES SHALL BE INSPECTED DAILY BY THE CONTRACTOR AND MAINTAINED TO ENSURE CONTINUED PROPER FUNCTIONING. WRITTEN RECORDS SHALL BE KEPT OF WEEKLY REVIEWS OF THE TESC FACILITIES DURING THE WET SEASON (OCTOBER 1 TO MARCH 31) AND OF MONTHLY REVIEWS DURING THE DRY SEASON (APRIL 1 TO SEPTEMBER 30).**

**ANY AREAS OF EXPOSED SOILS, INCLUDING ROADWAY EMBANKMENTS, THAT WILL NOT BE DISTURBED FOR TWO DAYS DURING THE WET SEASON OR 14 DAYS DURING THE DRY SEASON SHALL BE IMMEDIATELY STABILIZED WITH THE APPROVED TESC METHODS (E.G. SEEDING, MULCHING, PLASTIC COVERING, STRAW, CRUSHED ROCK).**

**SITE RESTORATION: (BMP C120) ALL DENUDED SOIL AREAS SHALL BE SEEDED BY THE CONTRACTOR WITH A MIX SUITABLE FOR THE PARTICULAR APPLICATION. THE SEED MIX SHALL BE AS RECOMMENDED BY A QUALIFIED HORTICULTURIST, AND APPROVED BY THE ENGINEER. THE CONTRACTOR SHALL BE RESPONSIBLE FOR SEED GERMINATION AND MAINTENANCE OF ALL SUCH SEEDED AREAS UNTIL NEW GRASS IS THICK AND A HEIGHT OF 1 INCH MINIMUM.**

**WETS AND BLANKETS: BMP C122 - USE AS RECOMMENDED IN AREAS GREATER THAN 2:1 SLOPE AND WITH MORE THAN 10' OF VERTICAL RELIEF TO STABILIZE SEEDING AND EROSION.**

**ANY AREA NEEDING TESC MEASURES THAT DO NOT REQUIRE IMMEDIATE ATTENTION SHALL BE ADDRESSED WITHIN 14 DAYS.**

**CONTRACTOR SHALL ENSURE THAT ALL SOIL, MUD, SILT DEBRIS, ETC. GENERATED BY THIS PROJECT IS KEPT OFF OF AND OUT OF ALL ROADS AND DRIVEWAYS. CONTRACTOR SHALL CLEAN AT HIS OWN EXPENSE ANY PUBLIC OR PRIVATE PROPERTY (ROAD, LAWN, DRIVEWAY, EMBANKMENT, DITCH, ETC.) WHICH IS SOILED, MUDDIED, OR DISTURBED AS A RESULT OF THIS PROJECT.**

**TEAR DOWN: REMOVE COMPLETELY ALL TEMPORARY EROSION CONTROL STRUCTURES ONLY AFTER PERMANENT EROSION CONTROL STRUCTURES AND PAVED AREAS ARE COMPLETED AND ALL NEW GRASS SEED HAS TAKEN ROOT AND HAS GROWN TO A THICK MAT CONDITION, AT LEAST 1-INCH IN LENGTH.**

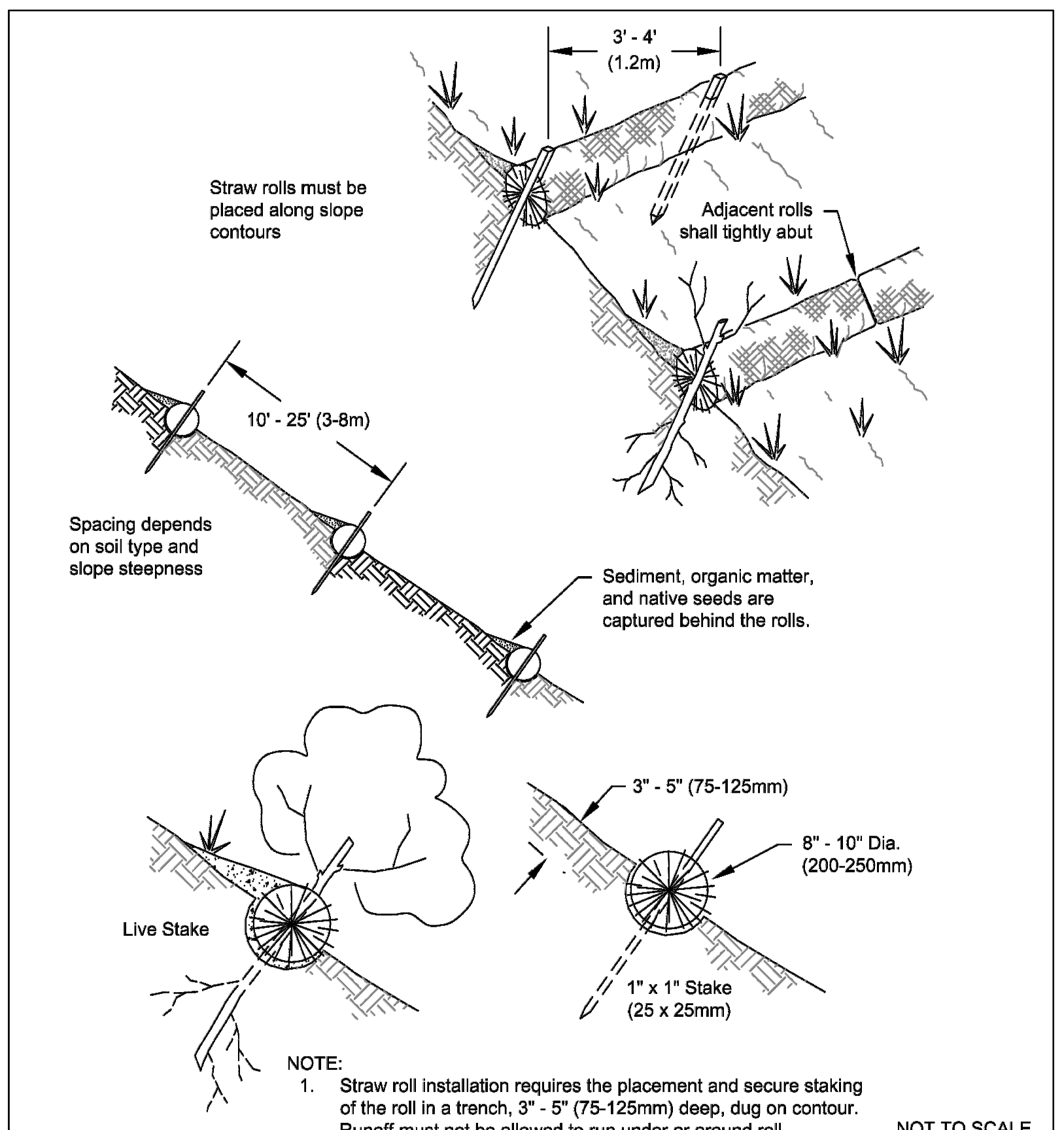

**PLAN SHEETS IN SET:**

1. COVER SHEET AND TESC DETAILS
2. WATER SYSTEM SITE PLANS
3. STREAM UNDERCROSSING AND PROFILE
4. PUMPHOUSE AND PROCESS DIAGRAM (NOT YET PART OF SET)
5. DETAILS (IF NEEDED)

**DEPARTMENT OF ECOLOGY**  
State of Washington

**BMP C235 Figure II-4.2.14**  
**Wattles**

Revised November 2015

Please see <http://www.ecy.wa.gov/copyright.html> for copyright notice including permissions, limitation of liability, and disclaimer.

1	1/13/21	CG	UPDATED CONTACT INFORMATION
No.	DATE	INIT.	REVISION



PO BOX 99 SEDRO-WOOLLEY, WA ~ WWW.GECORP.NET ~ 360-404-5058

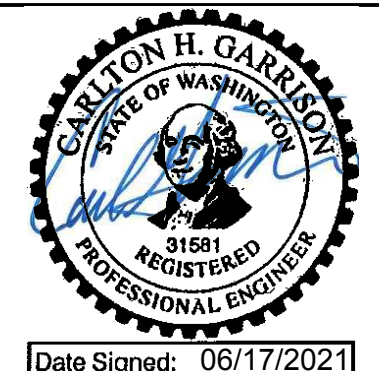

**BLACKACRE GROUP B WATER SYSTEM**

**CARNATION, WA**

**COVER SHEET**

**AND TESC NOTES AND DETAILS**

DRAWN/DESIGNED BY:	CAD FILE NUMBER:
CG	...SITE PLANS - 20042...
CHECKED BY:	COUNTY:
CG	KING COUNTY
DATE:	JOB NUMBER:
6/18/21	20042
SCALE:	
HORIZONTAL SEE PLAN	
VERTICAL N/A	
1 OF 4	



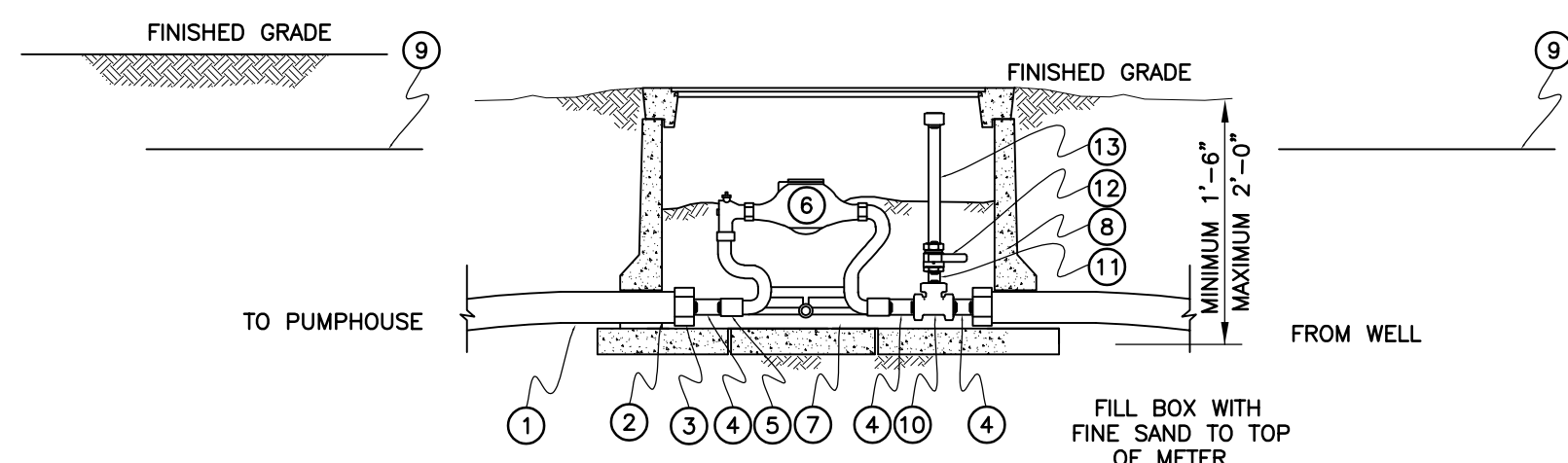

**NOTES:**  
 1. FLUSH OUT PIPE AND LINESSETTER BEFORE INSTALLING METER. DO NOT ALLOW MUD OR FOREIGN MATERIAL TO ENTER ANY TUBING OR FITTINGS.  
 2. LOCATE WIRE NOT SHOWN, SEE TRENCH DETAIL

SOURCE\_METER\_DETAIL  
NTS

BILL OF MATERIALS		
NO.	NOMENCLATURE	REQ'D.
1	2" HDPE PIPE	2
2	2" ADAPTER, HDPE HEAT FUSED BY 2" IPT	2
3	2" x 1" BRASS BUSHING	2
4	1" x 1-1/2" LONG NO LEAD BRASS NIPPLE	3
5	1" THREADED COUPLER (IF REQUIRED), NO LEAD BRASS	2
6	METER, 1" SENSUS OR EQUAL	1
7	METER SETTER, 1", A.Y. MCDONALD OR EQUAL	1
8	CONCRETE OR PLASTIC METER BOX & COVER	1
9	MAGNETIC MARKING TAPE	1
10	1" x 1/2" x 1" TEE, NO LEAD BRASS - INSTALL ON WELL SIDE OF METER	2
11	1/2" NIPPLE, NO LEAD BRASS	1
12	1/2" NO LEAD BRASS BALL VALVE, A.Y. MACDONALD OR EQUAL	1
13	1/2" x 12" NIPPLE AND CAP, NO LEAD BRASS. UNSCREW CAP FOR SOURCE WATER SAMPLING	1

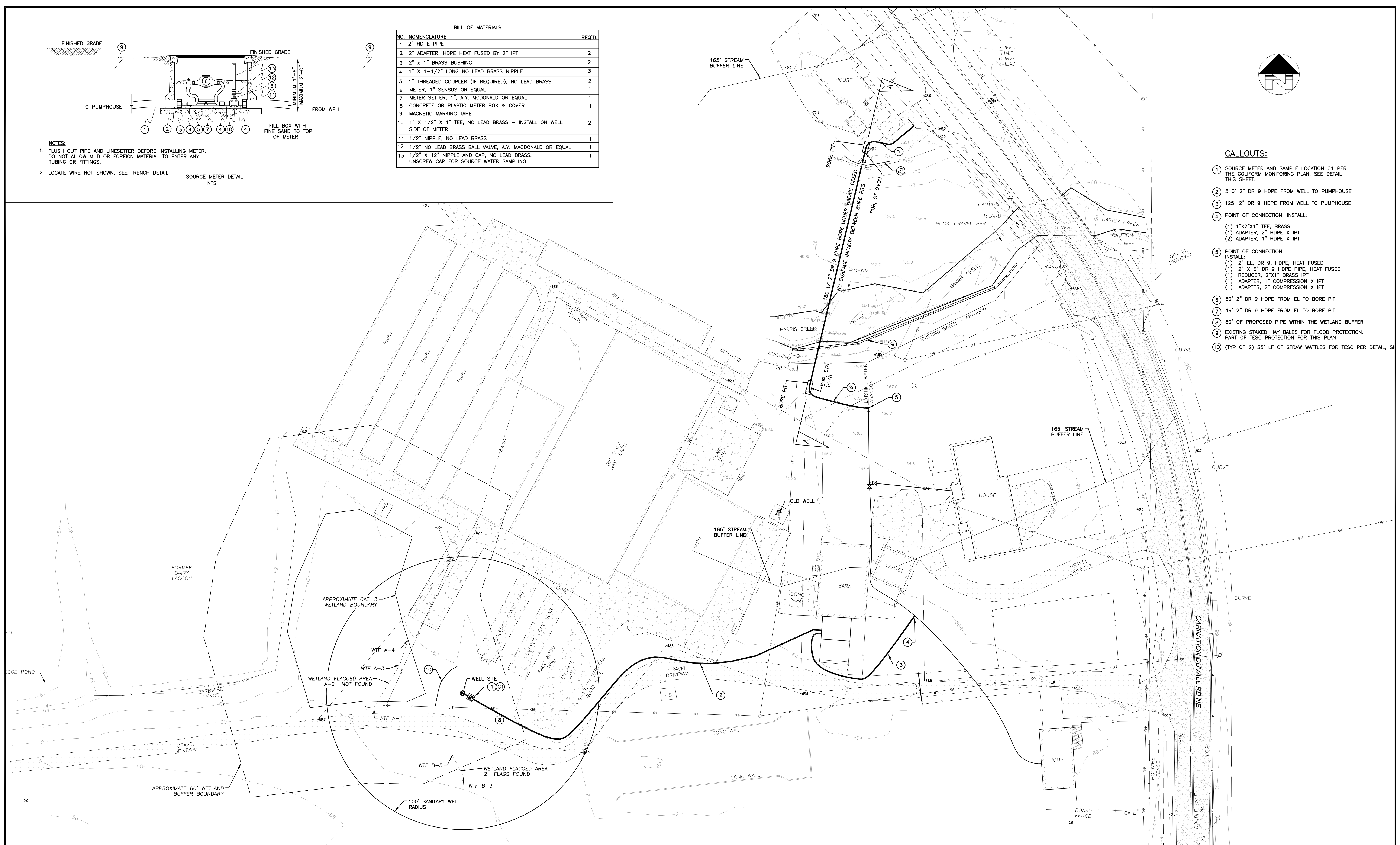

- CALLOUTS:**
- ① SOURCE METER AND SAMPLE LOCATION C1 PER THE COLIFORM MONITORING PLAN, SEE DETAIL THIS SHEET.
  - ② 310' 2" DR 9 HDPE FROM WELL TO PUMPHOUSE
  - ③ 125' 2" DR 9 HDPE FROM WELL TO PUMPHOUSE
  - ④ POINT OF CONNECTION, INSTALL:  
 (1) 1"x2"x1" TEE, BRASS  
 (1) ADAPTER, 2" HDPE X IPT  
 (2) ADAPTER, 1" HDPE X IPT
  - ⑤ POINT OF CONNECTION INSTALL:  
 (1) 2" EL, DR 9, HDPE, HEAT FUSED  
 (1) 2" x 6" DR 9 HDPE PIPE, HEAT FUSED  
 (1) REDUCER, 2"x1" BRASS IPT  
 (1) ADAPTER, 1" COMPRESSION X IPT  
 (1) ADAPTER, 2" COMPRESSION X IPT
  - ⑥ 50' 2" DR 9 HDPE FROM EL TO BORE PIT
  - ⑦ 46' 2" DR 9 HDPE FROM EL TO BORE PIT
  - ⑧ 50' OF PROPOSED PIPE WITHIN THE WETLAND BUFFER
  - ⑨ EXISTING STAKED HAY BALES FOR FLOOD PROTECTION. PART OF TESC PROTECTION FOR THIS PLAN
  - ⑩ (TYP OF 2) 35' LF OF STRAW WATTLES FOR TESC PER DETAIL, SH

#	DATE	BY	REVISIONS
1	6/8/21	CG	ADDED BIOLOGIST'S MARKUPS
No.	DATE	INIT.	REVISION

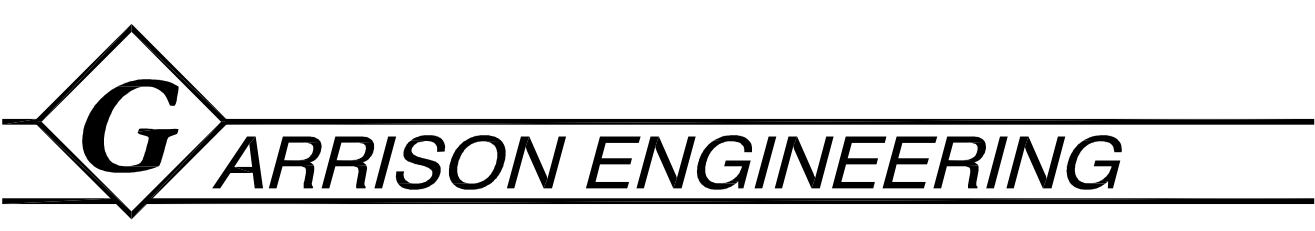

PO BOX 99 SEDRO-WOOLLEY, WA - WWW.GECORP.NET

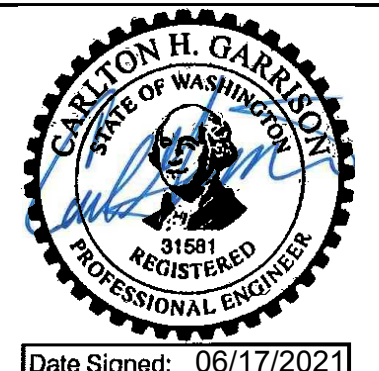

BLACKACRE GROUP B WATER SYSTEM  
 CARNATION, KING COUNTY, WA  
 WATER SYSTEM SITE PLAN

DRAWN/DESIGNED BY: CG	CAD FILE NUMBER: SITEPLAN...
CHECKED BY: CG	COUNTY: KING COUNTY
DATE: 5/4/21	JOB NUMBER: 20042
SCALE: HORIZONTAL 1"=30' VERTICAL N/A	2 OF 4

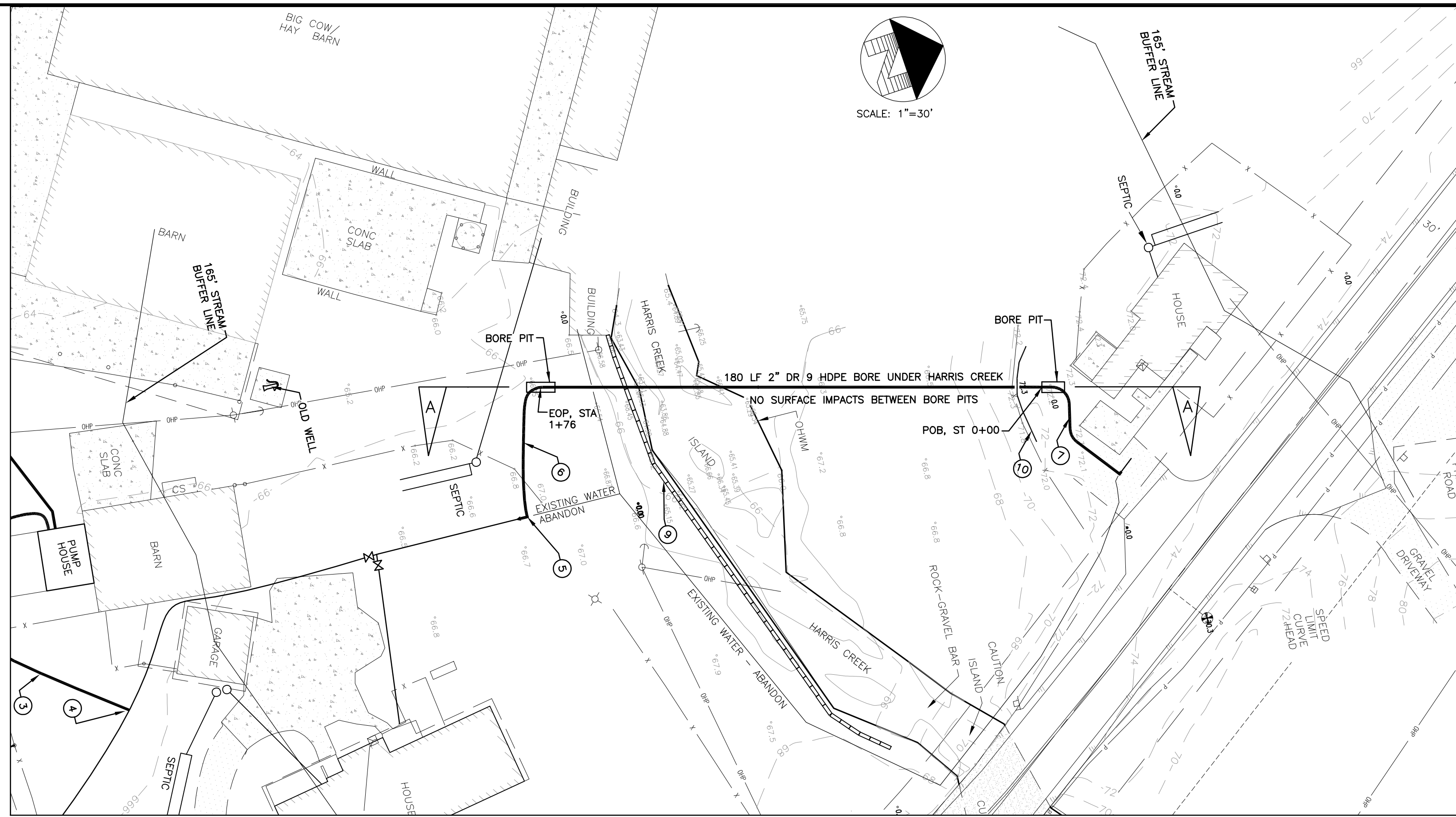

HARRIS CREEK 2" PIPELINE UNDERCROSSING - PLAN VIEW

SCALE: 1"=30'

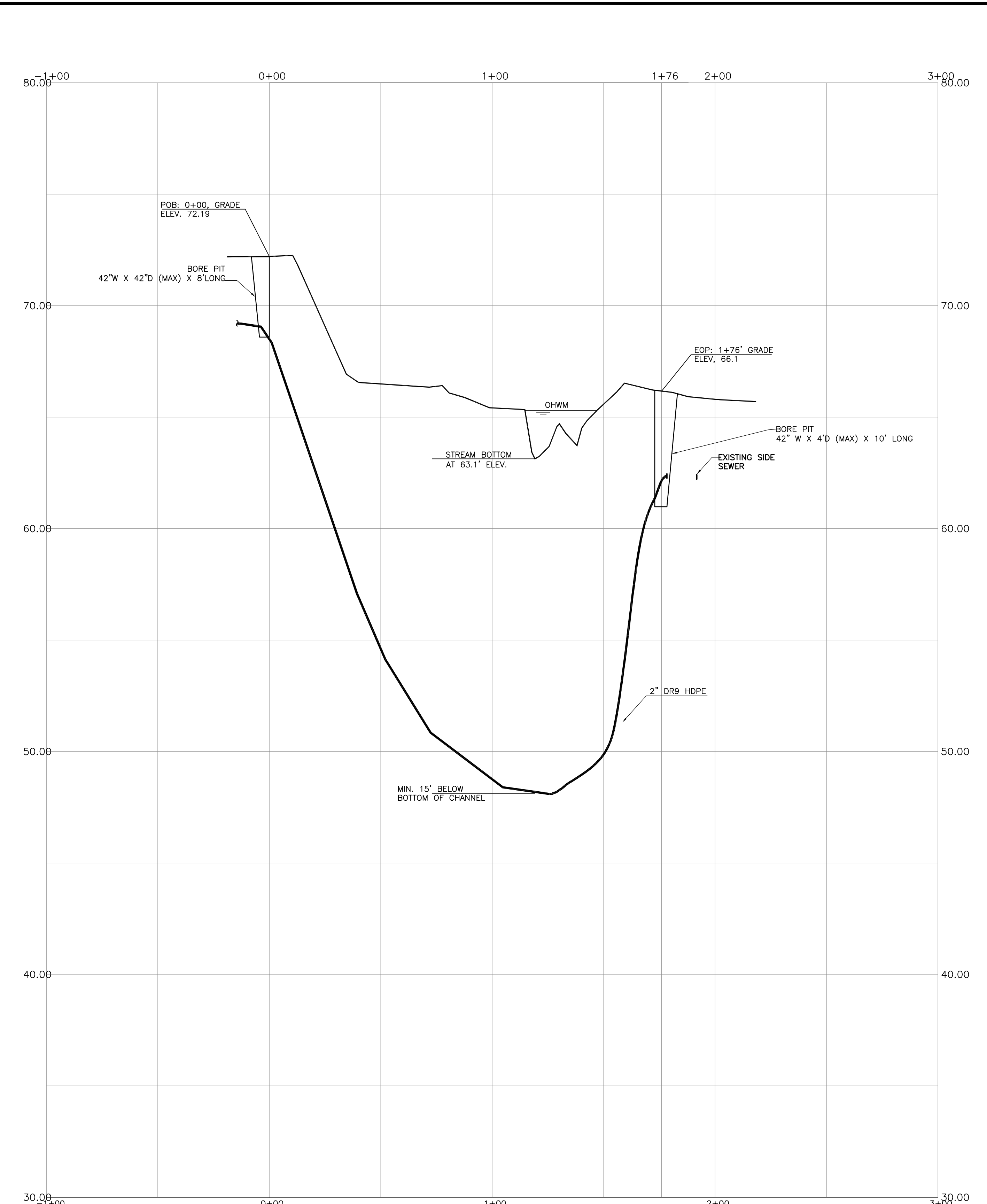

HARRIS CREEK 2" PIPELINE UNDERCROSSING  
PROFILE VIEW - SECTION A-A

SCALE:  
1"=30' HORIZONTALLY  
1"=3' VERTICALLY

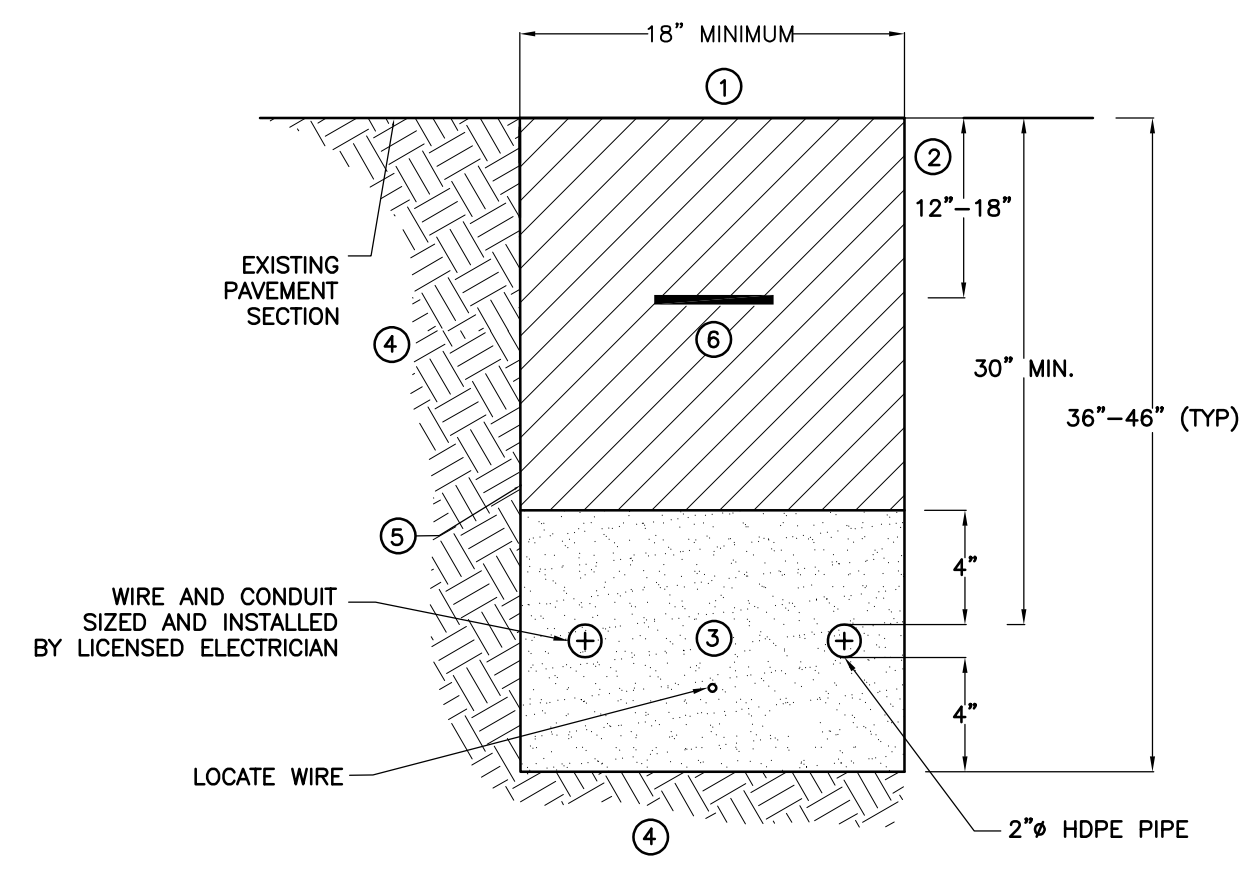

TRENCH DETAIL -- LAWN AREAS

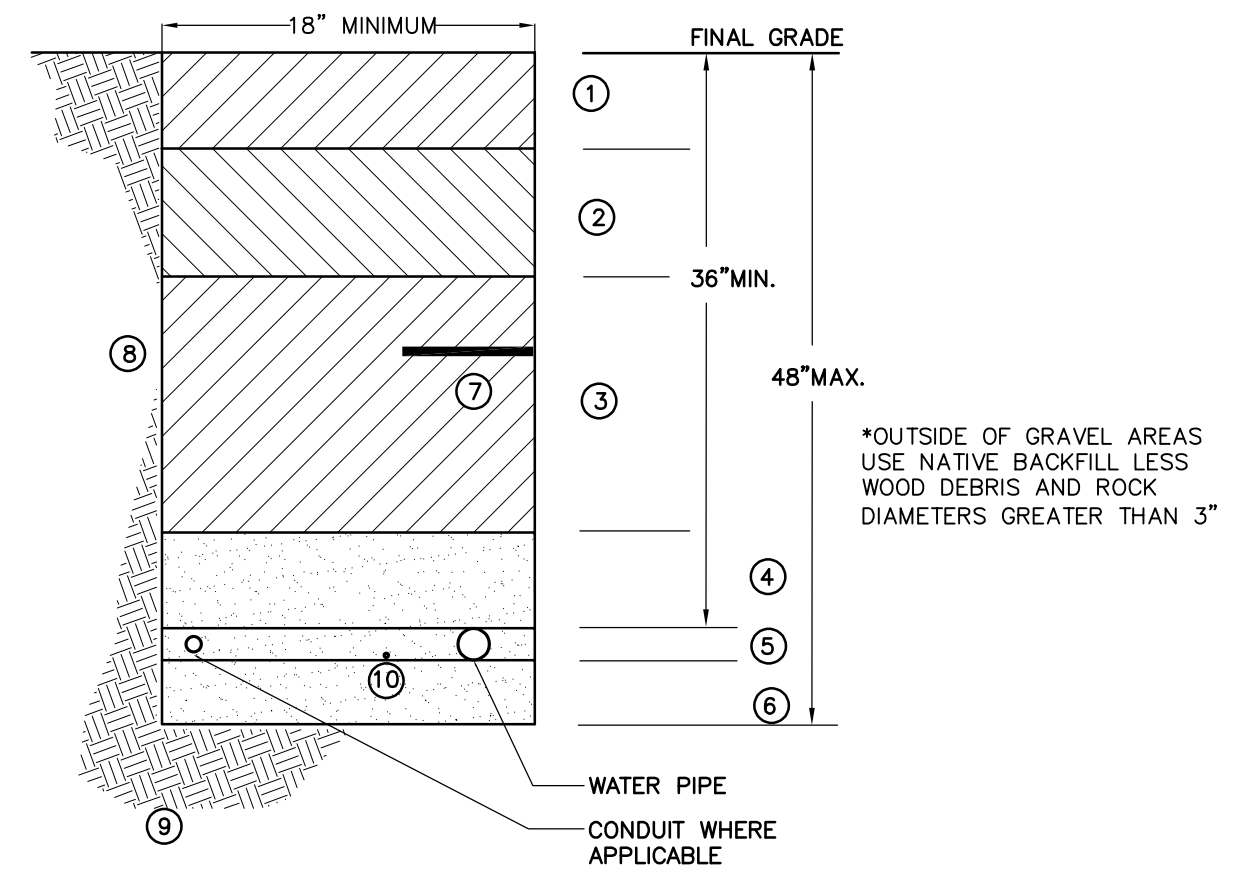

TRENCH DETAIL -- GRAVEL AREAS

- TRENCH NOTES:**
- RESTORATION: OUTSIDE OF ROAD AREAS, RESTORATION OF SURFACE SHALL CONSIST OF NATIVE SOIL WITH THE EXEMPTION OF ALL ROCKS GREATER THAN 3 INCH DIAMETER, BLENDING THE TOP OF TRENCH WITH SURROUNDING GRADE, REMOVING ALL SPOILS FROM THE SITE, AND RESEEDING ALL EXCAVATED AREAS.
  - BACKFILL SHALL BE NATIVE MATERIAL COMPACTED IN 8" LIFTS. IN CASES WHERE THE MATERIAL IS TOO WET OR UNSUITABLE, PIT RUN GRAVEL SHALL BE USED. IF THE SOIL IS UNSUITABLE, OR IF PIT RUN USED, THE TOP 6" SHALL BE IMPORTED TOP SOIL.
  - SAND OR BUCKSHOT GRAVEL TO BE FILLED TO 4"-6" ABOVE TOP OF PIPE. COMPACT WITH VIBRATORY PLATE COMPACTOR.
  - UNDISTURBED EARTH
  - TRENCH LINE: TRENCH WIDTH SHALL BE IN ACCORDANCE WITH CURRENT WSDOT STANDARD SPECIFICATION
  - BURY ALL WATER PIPE WITH 6" BLUE MAGNETIC MARKING TAPE LABELED "WATER" 12"-18" BELOW GRADE.
- NOTES:**
- 12" MINIMUM SPACING BETWEEN ALL PIPES AND CONDUITS
  - IF PIPE CROSSES A SEPTIC PIPE, SLEEVE WATER PIPE AT CROSSING WITH 20' SECTION OF 3" PVC PIPE CENTERED ON SEPTIC PIPE.

- TRENCH NOTES:**
- ON GRAVEL ROAD AREAS AND EDGES, 3" MINUS GRAVEL IN ACCORDANCE WITH WSDOT SPECIFICATION 9-03.10 TO A DEPTH OF 6".
  - ON GRAVEL ROAD AREAS AND EDGES, GRAVEL BASE IN ACCORDANCE WITH WSDOT SPECIFICATION 9-03.10 TO A DEPTH OF 8".
  - 8" CRUSHED, PIT RUN, OR NATIVE BACKFILL IF WELL DRAINED AND COMPACTABLE TO 95% IN ACCORDANCE WITH WSDOT SPECIFICATION 9-03.19
  - 4"-6" OF SAND BACKFILL TO BE HAND COMPACTED ABOVE CROWN OF PIPE.
  - HAND COMPACTED SAND BACKFILL TO BE TAMPED AROUND PIPE. THICKNESS EQUALS OUTSIDE DIAMETER OF PIPE.
  - 4"-6" OF COMPACTED SAND BACKFILL
  - METALLIC LOCATE TAPE
  - TRENCH LINE. TRENCH WIDTH SHALL BE IN ACCORDANCE WITH WSDOT STANDARD SPECIFICATION 7-09.3 (7)
  - UNDISTURBED EARTH
  - LOCATE WIRE, COPPERHEAD HIGH STRENGTH TRACER WIRE, PART # 1230B-FS, OR EQUAL.
- NOTES:**
- 12" MINIMUM SPACING BETWEEN ALL PIPES AND CONDUITS
  - IF PIPE CROSSES A SEPTIC PIPE, SLEEVE WATER PIPE AT CROSSING WITH 20' SECTION OF 3" PVC PIPE CENTERED ON SEPTIC PIPE.

#	DATE	BY	REVISIONS
No.	DATE	INIT.	REVISION



PO BOX 99 SEDRO-WOLLEY, WA - WWW.GECORP.NET

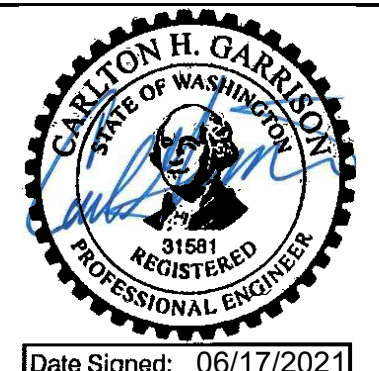

BLACKACRE GROUP B WATER SYSTEM  
CARNATION, KING COUNTY, WA  
STREAM UNDERCROSSING PLAN AND PROFILE

DRAWN/DESIGNED BY: CG	CAD FILE NUMBER: SITEPLANS...
CHECKED BY: CG	COUNTY: KING COUNTY
DATE: 5/4/21	JOB NUMBER: 20042
SCALE: HORIZONTAL VERTICAL	SEE PLAN SEE PLAN
3 OF 4	

# SEPA ENVIRONMENTAL CHECKLIST

## ***Purpose of checklist:***

Governmental agencies use this checklist to help determine whether the environmental impacts of your proposal are significant. This information is also helpful to determine if available avoidance, minimization or compensatory mitigation measures will address the probable significant impacts or if an environmental impact statement will be prepared to further analyze the proposal.

## ***Instructions for applicants:***

This environmental checklist asks you to describe some basic information about your proposal. Please answer each question accurately and carefully, to the best of your knowledge. You may need to consult with an agency specialist or private consultant for some questions. You may use "not applicable" or "does not apply" only when you can explain why it does not apply and not when the answer is unknown. You may also attach or incorporate by reference additional studies reports. Complete and accurate answers to these questions often avoid delays with the SEPA process as well as later in the decision-making process.

The checklist questions apply to all parts of your proposal, even if you plan to do them over a period of time or on different parcels of land. Attach any additional information that will help describe your proposal or its environmental effects. The agency to which you submit this checklist may ask you to explain your answers or provide additional information reasonably related to determining if there may be significant adverse impact.

## ***Instructions for Lead Agencies:***

Please adjust the format of this template as needed. Additional information may be necessary to evaluate the existing environment, all interrelated aspects of the proposal and an analysis of adverse impacts. The checklist is considered the first but not necessarily the only source of information needed to make an adequate threshold determination. Once a threshold determination is made, the lead agency is responsible for the completeness and accuracy of the checklist and other supporting documents.

## ***Use of checklist for nonproject proposals:***

For nonproject proposals (such as ordinances, regulations, plans and programs), complete the applicable parts of sections A and B plus the [SUPPLEMENTAL SHEET FOR NONPROJECT ACTIONS \(part D\)](#). Please completely answer all questions that apply and note that the words "project," "applicant," and "property or site" should be read as "proposal," "proponent," and "affected geographic area," respectively. The lead agency may exclude (for non-projects) questions in Part B - Environmental Elements –that do not contribute meaningfully to the analysis of the proposal.

## ***A. Background*** [\[HELP\]](#)

1. Name of proposed project, if applicable: Gaisford Waterline
2. Name of applicant: Julie Gaisford
3. Address and phone number of applicant and contact person:

8519 SR 203  
Carnation, WA 98014  
206-963-4203

4. Date checklist prepared: May 20, 2021
5. Agency requesting checklist: King County
6. Proposed timing or schedule (including phasing, if applicable): Immediately after permit issuance.

7. Do you have any plans for future additions, expansion, or further activity related to or connected with this proposal? If yes, explain. No

8. List any environmental information you know about that has been prepared, or will be prepared, directly related to this proposal.

A critical area report prepared by Altmann Oliver Associates identified a Category III in the vicinity of the new well; this was confirmed in CADS20-0348. Harris Creek is within the project area. An HPA Permit will be applied for by MacWhinney Environmental Consulting, LLC to address the pipeline crossing of the Harris Creek. It isn't possible to apply for an HPA without a SEPA determination, so upon receipt of King County's SEPA determination, the HPA application will be submitted.

9. Do you know whether applications are pending for governmental approvals of other proposals directly affecting the property covered by your proposal? If yes, explain.  
None.

10. List any government approvals or permits that will be needed for your proposal, if known. Well approval was received from King County Department of Health (Activity SR1449605, approved 4/20/21). Hydraulic Project Approval will be requested from the WDFW upon receipt of SEPA determination from King County.

11. Give brief, complete description of your proposal, including the proposed uses and the size of the project and site. There are several questions later in this checklist that ask you to describe certain aspects of your proposal. You do not need to repeat those answers on this page. (Lead agencies may modify this form to include additional specific information on project description.)

This SEPA Checklist is being prepared in support of a new water distribution line to serve three homes. The current well was not legally installed and is not able to be approved due to its proximity to buildings. A new well was approved by the King County Health Department (Activity SR1449605) on 4/20/21.

Connecting the three homes to this new well will involve two components:

- a) A section of new waterline will be installed from the new well to the existing waterlines. This will be adequate to provide water to house 8519 and 8501. This new pipeline will be installed by excavating a trench adjacent to an existing gravel road within a disturbed / developed area of the farm. This portion of the project is exempt from SEPA.
- b) In order to provide water to the house at 8629 NE Carnation Duvall Road, it is necessary to cross Harris Creek, a Type F stream. The existing waterline crosses the creek as a suspended pipe attached to a state-owned bridge on S.R. 203; permission from the state was never granted for this pipeline. For a variety of reasons, it is not feasible to use this route. The WADOT is planning

to replace the bridge, and the waterline must be removed. Additionally, the owner has explored purchasing water from Water District 119, but this option, at an estimate of at least \$325,000, was cost-prohibitive; additionally, it would require crossing Harris Creek. The option being proposed is to excavate a 3-foot by 3-foot hole in the lawn of 8629 property. The excavation will be 15-feet deep, and will facilitate a directional bore under Harris Creek. The 2" waterline will be inserted in the bore line, and will be connected to the waterline on the south side of Harris Creek. Surface impacts include two excavations, one on either side of Harris Creek, within existing lawn areas.

12. Location of the proposal. Give sufficient information for a person to understand the precise location of your proposed project, including a street address, if any, and section, township, and range, if known. If a proposal would occur over a range of area, provide the range or boundaries of the site(s). Provide a legal description, site plan, vicinity map, and topographic map, if reasonably available. While you should submit any plans required by the agency, you are not required to duplicate maps or detailed plans submitted with any permit applications related to this checklist.

The site address is 8519 Carnation Duvall Road, tax parcel number 0425079017 and 8625 Carnation Duvall Road, tax parcel number 0425079016 in SE Section 4 Township 25 N Range 07E.

## **B. Environmental Elements** [\[HELP\]](#)

### **1. Earth** [\[help\]](#)

#### a. General description of the site:

The main property is 10 acres; the smaller parcel 0.85 acres. The parcels have been developed for a century as a dairy farm, and contain three houses and several farm buildings.

(circle one): Flat, rolling, hilly, steep slopes, mountainous, other rolling

#### b. What is the steepest slope on the site (approximate percent slope)?

Approx.1%

#### c. What general types of soils are found on the site (for example, clay, sand, gravel, peat, muck)? If you know the classification of agricultural soils, specify them and note any agricultural land of long-term commercial significance and whether the proposal results in removing any of these soils.

Soils on the site are mapped as Barneston gravelly ashy coarse sand, Nooksack silt loam, and Seattle Muck.

#### d. Are there surface indications or history of unstable soils in the immediate vicinity? If so, describe.

No.

#### e. Describe the purpose, type, total area, and approximate quantities and total affected area of any filling, excavation, and grading proposed. Indicate source of fill.

No fill is necessary to install the waterline. Materials excavated will be replaced after pipe installation. It is possible that up to 20 cubic yards of gravel will be placed in the new trench that will connect the new well and the existing waterlines. This portion of the project is exempt from SEPA, however.

#### f. Could erosion occur as a result of clearing, construction, or use? If so, generally describe.

Erosion is not expected.

g. About what percent of the site will be covered with impervious surfaces after project construction (for example, asphalt or buildings)?

The proposed waterline installation will not change the impervious surface over existing condition.

Proposed measures to reduce or control erosion, or other impacts to the earth, if any:

## 2. Air [\[help\]](#)

a. What types of emissions to the air would result from the proposal during construction, operation, and maintenance when the project is completed? If any, generally describe and give approximate quantities if known.

Dust and engine exhaust during construction and automobile exhaust when the project is under construction. This is anticipated to take approximately two weeks.

b. Are there any off-site sources of emissions or odor that may affect your proposal? If so, generally describe.

No.

c. Proposed measures to reduce or control emissions or other impacts to air, if any:

During construction equipment will be turned off when not in use.

## 3. Water [\[help\]](#)

a. Surface Water: [\[help\]](#)

1) Is there any surface water body on or in the immediate vicinity of the site (including year-round and seasonal streams, saltwater, lakes, ponds, wetlands)? If yes, describe type and provide names. If appropriate, state what stream or river it flows into.

Harris Creek, a Type F tributary to the Snoqualmie River, is within the project area.

2) Will the project require any work over, in, or adjacent to (within 200 feet) the described waters? If yes, please describe and attach available plans.

Yes, a 2-inch pipe will be placed 15-feet below the bottom of the stream channel. Please refer to the civil engineering plans by Garrison Engineering.

3) Estimate the amount of fill and dredge material that would be placed in or removed from surface water or wetlands and indicate the area of the site that would be affected. Indicate the source of fill material.

None

4) Will the proposal require surface water withdrawals or diversions? Give general description, purpose, and approximate quantities if known.

No

5) Does the proposal lie within a 100-year floodplain? If so, note location on the site plan.

Yes, the majority of the project is within the 100-year floodplain of the Snoqualmie River. See accompanying plan.

6) Does the proposal involve any discharges of waste materials to surface waters? If so, describe the type of waste and anticipated volume of discharge.

No

b. Ground Water: [\[help\]](#)

- 1) Will groundwater be withdrawn from a well for drinking water or other purposes? If so, give a general description of the well, proposed uses and approximate quantities withdrawn from the well. Will water be discharged to groundwater? Give general description, purpose, and approximate quantities if known.

No

- 2) Describe waste material that will be discharged into the ground from septic tanks or other sources, if any (for example: Domestic sewage; industrial, containing the following chemicals. . . ; agricultural; etc.). Describe the general size of the system, the number of such systems, the number of houses to be served (if applicable), or the number of animals or humans the system(s) are expected to serve.

None.

c. Water runoff (including stormwater):

- 1) Describe the source of runoff (including storm water) and method of collection and disposal, if any (include quantities, if known). Where will this water flow? Will this water flow into other waters? If so, describe.

The project will not create new impervious surface. No runoff is anticipated.

- 2) Could waste materials enter ground or surface waters? If so, generally describe.  
None expected or anticipated.

- 3) Does the proposal alter or otherwise affect drainage patterns in the vicinity of the site? If so, describe.

Not expected or anticipated.

d. Proposed measures to reduce or control surface, ground, and runoff water, and drainage pattern impacts, if any:

**4. Plants** [\[help\]](#)

a. Check the types of vegetation found on the site:

- deciduous tree: alder, maple, aspen, other  
 evergreen tree: fir, cedar, pine, other  
 shrubs  
 grass  
 pasture  
 crop or grain  
 Orchards, vineyards or other permanent crops.  
 wet soil plants: cattail, buttercup, bullrush, skunk cabbage, other  
 water plants: water lily, eelgrass, milfoil, other  
 other types of vegetation

b. What kind and amount of vegetation will be removed or altered?

To install the water pipeline under the stream, two surface excavations within existing lawn areas will be necessary. These holes will provide access for directional boring under the stream, and will affect 9 square feet of lawn on each side of Harris Creek (total 18 s.f. of lawn temporarily disturbed.)

c. List threatened and endangered species known to be on or near the site.

Bald eagles, which are federally listed a species of concern are incidental visitors to the general area. No nests are known. Harris Creek supports coho, steelhead/rainbow, and cutthroat trout. Steelhead and coho are listed as threatened.

d. Proposed landscaping, use of native plants, or other measures to preserve or enhance vegetation on the site, if any:

None anticipated.

e. List all noxious weeds and invasive species known to be on or near the site.

Japanese knotweed (*Polygonum cuspidatum*)

reed canarygrass (*Phalaris arundinacea*)

Himalayan blackberry (*Rubus armeniacus*)

## 5. **Animals** [\[help\]](#)

a. List any birds and other animals which have been observed on or near the site or are known to be on or near the site.

birds: **hawk, heron, eagle, songbirds**, other: birds native to Western Washington

mammals: **deer, bear, elk, beaver, small mammals**: mammals native to Western Washington

fish: , **salmon, trout**,

b. List any threatened and endangered species known to be on or near the site.

Coho salmon and steelhead migrate through Harris Creek

c. Is the site part of a migration route? If so, explain.

Salmon migrate through Harris Creek seasonally.

d. Proposed measures to preserve or enhance wildlife, if any:

Using directional boring to go under Harris Creek is designed to avoid impact to fish and fish habitat. The depth of 15-feet was determined by the project engineer to be sufficiently deep to avoid dewatering the stream.

e. List any invasive animal species known to be on or near the site.

None known

## 6. **Energy and Natural Resources** [\[help\]](#)

a. What kinds of energy (electric, natural gas, oil, wood stove, solar) will be used to meet the completed project's energy needs? Describe whether it will be used for heating, manufacturing, etc.

The completed project will not alter the energy needs of the site.



b. Would your project affect the potential use of solar energy by adjacent properties?

If so, generally describe.

No.

c. What kinds of energy conservation features are included in the plans of this proposal?

List other proposed measures to reduce or control energy impacts, if any:

None proposed.

## **7. Environmental Health** [\[help\]](#)

a. Are there any environmental health hazards, including exposure to toxic chemicals, risk of fire and explosion, spill, or hazardous waste, that could occur as a result of this proposal?

If so, describe. No

1) Describe any known or possible contamination at the site from present or past uses.

None known.

2) Describe existing hazardous chemicals/conditions that might affect project development and design. This includes underground hazardous liquid and gas transmission pipelines located within the project area and in the vicinity.

None known.

3) Describe any toxic or hazardous chemicals that might be stored, used, or produced during the project's development or construction, or at any time during the operating life of the project.

None anticipated.

4) Describe special emergency services that might be required.

None anticipated.

5) Proposed measures to reduce or control environmental health hazards, if any: None proposed.

### **b. Noise**

1) What types of noise exist in the area which may affect your project (for example: traffic, equipment, operation, other)?

Construction noises at 80 to 90 DBA range from 50' from noise sources may be expected during work hours for one to two days.

2) What types and levels of noise would be created by or associated with the project on a short-term or a long-term basis (for example: traffic, construction, operation, other)? Indicate what hours noise would come from the site.

Construction equipment will be turned off when not in use. Construction activities will be limited to daytime hours and will adhere to restrictions set forth in King County Code 12.86.520 (noise ordinance).

- 3) Proposed measures to reduce or control noise impacts, if any: Limit operation of equipment during business hours.

**8. Land and Shoreline Use** [\[help\]](#)

- a. What is the current use of the site and adjacent properties? Will the proposal affect current land uses on nearby or adjacent properties? If so, describe.

Residential single-family, land uses will be unaffected with this proposal.

- b. Has the project site been used as working farmlands or working forest lands? If so, describe. How much agricultural or forest land of long-term commercial significance will be converted to other uses as a result of the proposal, if any? If resource lands have not been designated, how many acres in farmland or forest land tax status will be converted to nonfarm or nonforest use?

Not to our knowlege

- 1) Will the proposal affect or be affected by surrounding working farm or forest land normal business operations, such as oversize equipment access, the application of pesticides, tilling, and harvesting? If so, how:

No

- c. Describe any structures on the site.

There are three existing single-family homes, barns, sheds, and other agricultural buildings on the parcels.

- d. Will any structures be demolished? If so, what?

No structures will be demolished.

- e. What is the current zoning classification of the site?

A35

- f. What is the current comprehensive plan designation of the site?

Agriculture

- g. If applicable, what is the current shoreline master program designation of the site?

Not Applicable

- h. Has any part of the site been classified as a critical area by the city or county? If so, specify. Critical areas have been identified by King County, including CARA II, Seismic Hazard Area, Category III Wetland, Type F stream, FEMA Floodplain, and Resource Shoreline.

- i. Approximately how many people would reside or work in the completed project?

The completed project will not change the number of residents. Currently, three family homes are present onsite.

- j. Approximately how many people would the completed project displace?

None.

- k. Proposed measures to avoid or reduce displacement impacts, if any:

None proposed.

L. Proposed measures to ensure the proposal is compatible with existing and projected land uses and plans, if any:

None Proposed .

m. Proposed measures to reduce or control impacts to agricultural and forest lands of long-term commercial significance, if any:

None Proposed.

## **9. Housing** [\[help\]](#)

a. Approximately how many units would be provided, if any? Indicate whether high, middle, or low-income housing.

No new net units will be provided.

b. Approximately how many units, if any, would be eliminated? Indicate whether high, middle, or low-income housing.

None.

c. Proposed measures to reduce or control housing impacts, if any:

None proposed.

## **10. Aesthetics** [\[help\]](#)

a. What is the tallest height of any proposed structure(s), not including antennas; what is the principal exterior building material(s) proposed?

N/A.

b. What views in the immediate vicinity would be altered or obstructed?

N/A.

b. Proposed measures to reduce or control aesthetic impacts, if any:

None proposed.

## **11. Light and Glare** [\[help\]](#)

a. What type of light or glare will the proposal produce? What time of day would it mainly occur?

N/A.

b. Could light or glare from the finished project be a safety hazard or interfere with views?  
No.

c. What existing off-site sources of light or glare may affect your proposal?  
None to our Knowledge .

d. Proposed measures to reduce or control light and glare impacts, if any:  
None proposed.

## **12. Recreation** [\[help\]](#)

- a. What designated and informal recreational opportunities are in the immediate vicinity?  
None.
- b. Would the proposed project displace any existing recreational uses? If so, describe.  
No.
- c. Proposed measures to reduce or control impacts on recreation, including recreation opportunities to be provided by the project or applicant, if any:  
None proposed.

## **13. Historic and cultural preservation** [\[help\]](#)

- a. Are there any buildings, structures, or sites, located on or near the site that are over 45 years old listed in or eligible for listing in national, state, or local preservation registers? If so, specifically describe.  
Historic barn onsite. Will not be impacted by proposal.
- b. Are there any landmarks, features, or other evidence of Indian or historic use or occupation? This may include human burials or old cemeteries. Are there any material evidence, artifacts, or areas of cultural importance on or near the site? Please list any professional studies conducted at the site to identify such resources.  
None to our knowledge.
- c. Describe the methods used to assess the potential impacts to cultural and historic resources on or near the project site. Examples include consultation with tribes and the department of archeology and historic preservation, archaeological surveys, historic maps, GIS data, etc.  
None.
- d. Proposed measures to avoid, minimize, or compensate for loss, changes to, and disturbance to resources. Please include plans for the above and any permits that may be required.  
None proposed.

## **14. Transportation** [\[help\]](#)

- a. Identify public streets and highways serving the site or affected geographic area and describe proposed access to the existing street system. Show on site plans, if any.  
Site is served by SR 203.
- b. Is the site or affected geographic area currently served by public transit? If so, generally describe. If not, what is the approximate distance to the nearest transit stop?  
No. The closest transit stop is in Carnation, approximately two miles away.
- c. How many additional parking spaces would the completed project or non-project proposal have? How many would the project or proposal eliminate?  
N/A.
- d. Will the proposal require any new or improvements to existing roads, streets, pedestrian, bicycle or state transportation facilities, not including driveways? If so, generally describe (indicate whether public or private).

None proposed.

- e. Will the project or proposal use (or occur in the immediate vicinity of) water, rail, or air transportation? If so, generally describe.  
No.
- f. How many vehicular trips per day would be generated by the completed project or proposal? If known, indicate when peak volumes would occur and what percentage of the volume would be trucks (such as commercial and nonpassenger vehicles). What data or transportation models were used to make these estimates?  
No net additional trips are expected to be generated by the completed project.
- g. Will the proposal interfere with, affect or be affected by the movement of agricultural and forest products on roads or streets in the area? If so, generally describe.  
No.
- h. Proposed measures to reduce or control transportation impacts, if any:  
None.

**15. Public Services** [\[help\]](#)

- a. Would the project result in an increased need for public services (for example: fire protection, police protection, public transit, health care, schools, other)? If so, generally describe.  
None anticipated.
- b. Proposed measures to reduce or control direct impacts on public services, if any.  
None proposed.

**16. Utilities** [\[help\]](#)

- a. Circle utilities currently available at the site:  
electricity, natural gas, water, refuse service, telephone, sanitary sewer, septic system,  
other \_\_\_\_\_
- c. Describe the utilities that are proposed for the project, the utility providing the service, and the general construction activities on the site or in the immediate vicinity which might be needed.  
No new utilities are proposed

**C. Signature** [\[HELP\]](#)

The above answers are true and complete to the best of my knowledge. I understand that the lead agency is relying on them to make its decision.

Signature: \_\_\_\_\_

Name of signee

Position and Agency/Organization \_\_\_\_\_

**D. Supplemental sheet for nonproject actions** [\[HELP\]](#)

(IT IS NOT NECESSARY to use this sheet for project actions)

Because these questions are very general, it may be helpful to read them in conjunction with the list of the elements of the environment.

When answering these questions, be aware of the extent the proposal, or the types of activities likely to result from the proposal, would affect the item at a greater intensity or at a faster rate than if the proposal were not implemented. Respond briefly and in general terms.

1. How would the proposal be likely to increase discharge to water; emissions to air; production, storage, or release of toxic or hazardous substances; or production of noise?

None

Proposed measures to avoid or reduce such increases are:

None

2. How would the proposal be likely to affect plants, animals, fish, or marine life?

None

Proposed measures to protect or conserve plants, animals, fish, or marine life are:  
Boring under Harris Creek has been proposed to minimize impacts to the stream and associated buffer..

3. How would the proposal be likely to deplete energy or natural resources?

None.

Proposed measures to protect or conserve energy and natural resources are:

None.

4. How would the proposal be likely to use or affect environmentally sensitive areas or areas designated (or eligible or under study) for governmental protection; such as parks, wilderness, wild and scenic rivers, threatened or endangered species habitat, historic or cultural sites, wetlands, floodplains, or prime farmlands?

The water line will cross under a stream to avoid impact to the stream and riparian habitat.

Proposed measures to protect such resources or to avoid or reduce impacts are:  
Waterline will be installed 15' below the bottom of the channel of the Type F watercourse.

5. How would the proposal be likely to affect land and shoreline use, including whether it would allow or encourage land or shoreline uses incompatible with existing plans?

Not applicable.

Proposed measures to avoid or reduce shoreline and land use impacts are:  
Directional boring under the stream is proposed to reduce impacts.

6. How would the proposal be likely to increase demands on transportation or public services and utilities?

None anticipated.

Proposed measures to reduce or respond to such demand(s) are:  
None.

7. Identify, if possible, whether the proposal may conflict with local, state, or federal laws or requirements for the protection of the environment.

None known.



October 28, 2020

AOA-6309

Julie Gaisford  
gaisfordlaw@centurytel.net

**SUBJECT: Partial Critical Areas Designation for Gaisford Well  
8501 Carnation Duvall Road, Parcel 042507-9017  
King County, WA**

Dear Julie:

On October 7, 2020 I conducted a wetland reconnaissance throughout the vicinity of a proposed well located in the southern portion of the subject property utilizing the methodology outlined in the May 2010 *Regional Supplement to the Corps of Engineers Wetland Delineation Manual: Western Mountains, Valleys, and Coast Region (Version 2.0)*.

One wetland (Wetland A) was identified and delineated to the west of the proposed well during the field investigation. **Attachment A** contains data sheets prepared for a representative location in both the wetland and upland. These data sheets document the vegetation, soils, and hydrology information that aided in the wetland boundary delineation.

### **Wetland A**

Wetland A consists of a shallow isolated topographic Depressional Hydrogeomorphic (HGM) class wetland that appears to be hydrologically supported by a high groundwater table.

Wetland A has been heavily disturbed through historic an on-going farming practices and at the time of the delineation vegetation within Wetland A consisted entirely of monotypic reed canarygrass (*Phalaris arundinacea*) with a fringe of Himalayan blackberry (*Rubus armeniacus*).

Wetland A meets the criteria for a Category III wetland with 5 Habitat Points (**Attachment B**). Category III wetlands with 5 Habitat Points require a standard 60-foot buffer plus 15-foot building setback from the wetland edge adjacent moderate impact land uses.



Julie Gaisford  
October 28, 2020  
Page 2

**Potential Wetland South of Farm Road**

During the reconnaissance, a potential wetland was observed to the south of the proposed well and existing farm road. Determining the presence of a wetland in this area would require a wetland hydrology review during the wet season. Since the proposed well is currently already located within the buffer of Wetland A, I did not conduct a definitive delineation or rating of the area south of the farm road.

If you have any questions regarding the delineation or rating, please give me a call.

Sincerely,

ALTMANN OLIVER ASSOCIATES, LLC

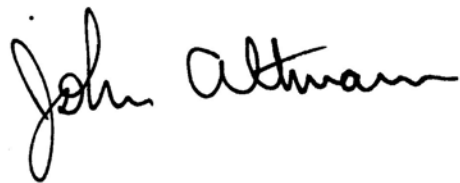
A handwritten signature in black ink that reads "John Altmann". The signature is written in a cursive, flowing style.

John Altmann  
Ecologist

Attachments

# Critical Areas Map

AOA - 6309

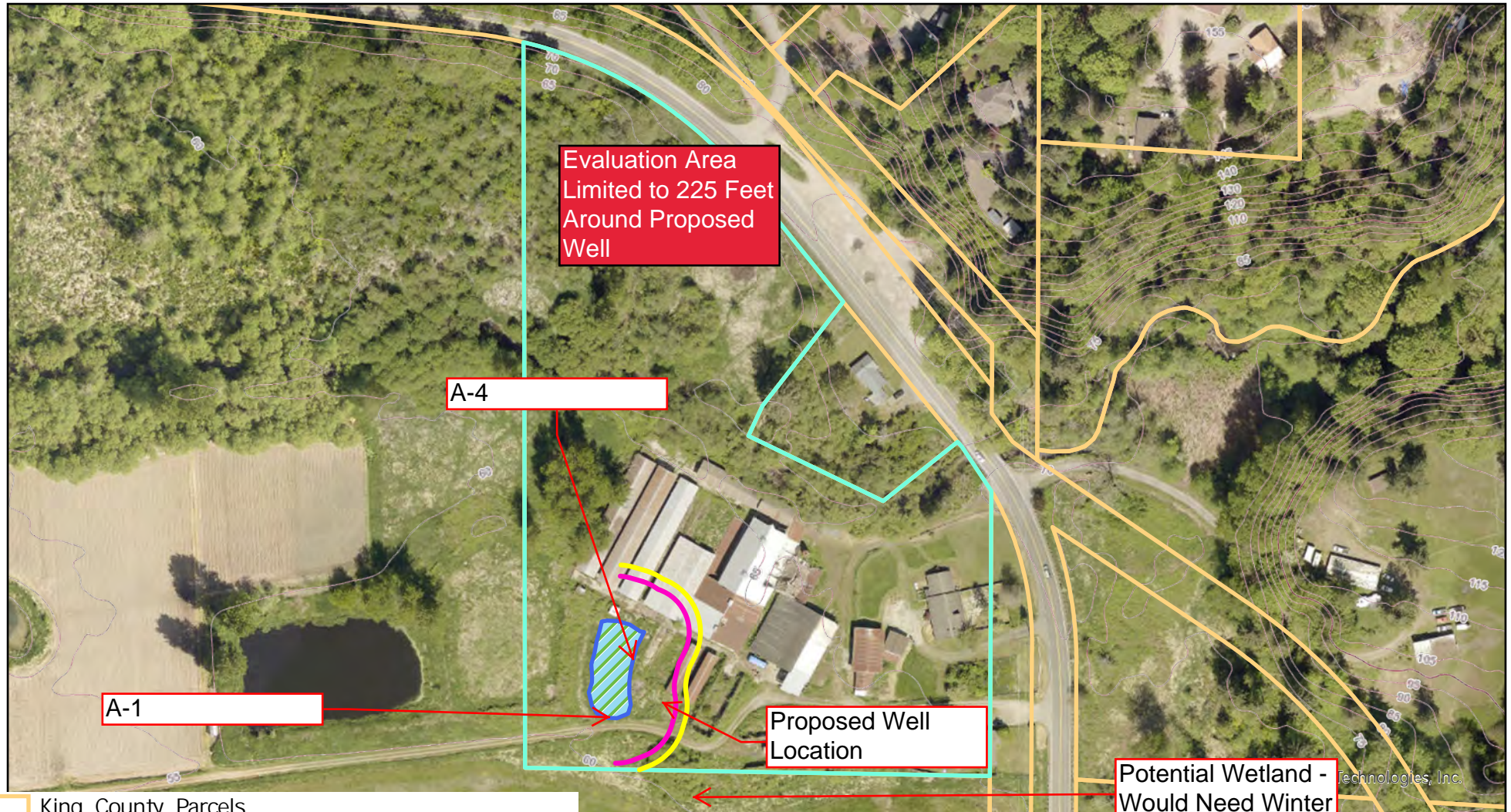

- King\_County\_Parcels
- Subject Property Parcel: 042507-9017
- Approximate Wetland A Cat. III
- Approximate 60' Buffer for Wetland A
- Approximate 15' Building Setback for Wetland A Buffer

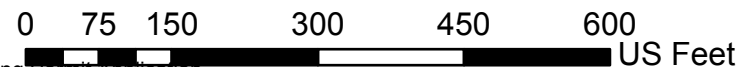

Gaisford Clearing & Grading Permit Application



# **ATTACHMENT A**

# **DATA SHEETS**

**WETLAND DETERMINATION DATA FORM – Western Mountains, Valleys, and Coast Region**

Project Site: Parcel: 042507-9017 City/County: King County/ Sampling Date: 10-7-20  
 Applicant/Owner: Gaisford State: WA Sampling Point: DP#1  
 Investigator(s): John Altmann Section, Township, Range: S4, T25, 7E  
 Landform (hillslope, terrace, etc.): \_\_\_\_\_ Local relief (concave, convex, none): \_\_\_\_\_ Slope (%): \_\_\_\_\_  
 Subregion (LRR): A Lat: 47.67799 Long: -121.90886 Datum: \_\_\_\_\_  
 Soil Map Unit Name: 157 NWI classification: N/A  
 Are climatic / hydrologic conditions on the site typical for this time of year? Yes  No  (If no, explain in Remarks.)  
 Are Vegetation , Soil , or Hydrology , significantly disturbed? Are "Normal Circumstances" present? Yes  No   
 Are Vegetation , Soil , or Hydrology , naturally problematic? (If needed, explain any answers in Remarks.)

**SUMMARY OF FINDINGS – Attach site map showing sampling point locations, transects, important features, etc.**

Hydrophytic Vegetation Present?	Yes <input checked="" type="checkbox"/>	No <input type="checkbox"/>	<b>Is the Sampled Area within a Wetland?</b>	Yes <input checked="" type="checkbox"/>	No <input type="checkbox"/>
Hydric Soil Present?	Yes <input checked="" type="checkbox"/>	No <input type="checkbox"/>		Yes <input checked="" type="checkbox"/>	No <input type="checkbox"/>
Wetland Hydrology Present?	Yes <input checked="" type="checkbox"/>	No <input type="checkbox"/>		Yes <input checked="" type="checkbox"/>	No <input type="checkbox"/>
Remarks: Located 10' into Wetland off of A-4					

**VEGETATION – Use scientific names of plants**

Tree Stratum (Plot size: _____)	Absolute % Cover	Dominant Species?	Indicator Status	Dominance Test Worksheet:																
1. _____	_____	_____	_____	Number of Dominant Species That Are OBL, FACW, or FAC: _____ (A)  Total Number of Dominant Species Across All Strata: _____ (B)  Percent of Dominant Species That Are OBL, FACW, or FAC: _____ (A/B)																
2. _____	_____	_____	_____																	
3. _____	_____	_____	_____																	
4. _____	_____	_____	_____																	
50% = _____, 20% = _____	_____	= Total Cover		<b>Prevalence Index worksheet:</b>  <table style="width: 100%; border: none;"> <tr> <td style="text-align: center;"><u>Total % Cover of:</u></td> <td style="text-align: center;"><u>Multiply by:</u></td> </tr> <tr> <td>OBL species _____</td> <td>x1 = _____</td> </tr> <tr> <td>FACW species _____</td> <td>x2 = _____</td> </tr> <tr> <td>FAC species _____</td> <td>x3 = _____</td> </tr> <tr> <td>FACU species _____</td> <td>x4 = _____</td> </tr> <tr> <td>UPL species _____</td> <td>x5 = _____</td> </tr> <tr> <td>Column Totals: _____ (A)</td> <td>_____ (B)</td> </tr> <tr> <td colspan="2" style="text-align: center;">Prevalence Index = B/A = _____</td> </tr> </table>	<u>Total % Cover of:</u>	<u>Multiply by:</u>	OBL species _____	x1 = _____	FACW species _____	x2 = _____	FAC species _____	x3 = _____	FACU species _____	x4 = _____	UPL species _____	x5 = _____	Column Totals: _____ (A)	_____ (B)	Prevalence Index = B/A = _____	
<u>Total % Cover of:</u>	<u>Multiply by:</u>																			
OBL species _____	x1 = _____																			
FACW species _____	x2 = _____																			
FAC species _____	x3 = _____																			
FACU species _____	x4 = _____																			
UPL species _____	x5 = _____																			
Column Totals: _____ (A)	_____ (B)																			
Prevalence Index = B/A = _____																				
<u>Sapling/Shrub Stratum</u> (Plot size: _____)																				
1. _____	_____	_____	_____																	
2. _____	_____	_____	_____																	
3. _____	_____	_____	_____																	
4. _____	_____	_____	_____																	
5. _____	_____	_____	_____																	
50% = _____, 20% = _____	_____	= Total Cover																		
<u>Herb Stratum</u> (Plot size: 10')																				
1. <u>Phalaris arundinacea</u>	<u>100</u>	<u>yes</u>	<u>FACW</u>																	
2. _____	_____	_____	_____																	
3. _____	_____	_____	_____																	
4. _____	_____	_____	_____																	
5. _____	_____	_____	_____																	
6. _____	_____	_____	_____																	
7. _____	_____	_____	_____																	
8. _____	_____	_____	_____																	
9. _____	_____	_____	_____																	
10. _____	_____	_____	_____																	
11. _____	_____	_____	_____																	
50% = <u>50</u> , 20% = <u>20</u>	<u>100</u>	= Total Cover																		
<u>Woody Vine Stratum</u> (Plot size: _____)																				
1. _____	_____	_____	_____																	
2. _____	_____	_____	_____																	
50% = _____, 20% = _____	_____	= Total Cover																		
% Bare Ground in Herb Stratum _____																				
<b>Hydrophytic Vegetation Indicators:</b> <input checked="" type="checkbox"/> 1 – Rapid Test for Hydrophytic Vegetation <input type="checkbox"/> 2 - Dominance Test is >50% <input type="checkbox"/> 3 - Prevalence Index is ≤3.0 <sup>1</sup> <input type="checkbox"/> 4 - Morphological Adaptations <sup>1</sup> (Provide supporting data in Remarks or on a separate sheet) <input type="checkbox"/> 5 - Wetland Non-Vascular Plants <sup>1</sup> <input type="checkbox"/> Problematic Hydrophytic Vegetation <sup>1</sup> (Explain)  <sup>1</sup> Indicators of hydric soil and wetland hydrology must be present, unless disturbed or problematic.																				
<b>Hydrophytic Vegetation Present?</b> Yes <input checked="" type="checkbox"/> No <input type="checkbox"/>																				

Remarks:

**SOIL**

Sampling Point: DP#1

**Profile Description: (Describe to the depth needed to document the indicator or confirm the absence of indicators.)**

Depth (inches)	Matrix		Redox Features				Texture	Remarks
	Color (moist)	%	Color (moist)	%	Type <sup>1</sup>	Loc <sup>2</sup>		
0-4	10 YR 3/2	100					loam	
5-15"	10 YR 4/1	90	10 YR 4/3	10			Clay/Loam	

<sup>1</sup>Type: C= Concentration, D=Depletion, RM=Reduced Matrix, CS=Covered or Coated Sand Grains.      <sup>2</sup>Location: PL=Pore Lining, M=Matrix

**Hydric Soil Indicators: (Applicable to all LRRs, unless otherwise noted.)**

- Histosol (A1)
- Histic Epipedon (A2)
- Black Histic (A3)
- Hydrogen Sulfide (A4)
- Depleted Below Dark Surface (A11)
- Thick Dark Surface (A12)
- Sandy Mucky Mineral (S1)
- Sandy Gleyed Matrix (S4)
- Sandy Redox (S5)
- Stripped Matrix (S6)
- Loamy Mucky Mineral (F1) **(except MLRA 1)**
- Loamy Gleyed Matrix (F2)
- Depleted Matrix (F3)
- Redox Dark Surface (F6)
- Depleted Dark Surface (F7)
- Redox Depressions (F8)

**Indicators for Problematic Hydric Soils<sup>3</sup>:**

- 2 cm Muck (A10)
- Red Parent Material (TF2)
- Very Shallow Dark Surface (TF12)
- Other (Explain in Remarks)

<sup>3</sup>Indicators of hydrophytic vegetation and wetland hydrology must be present, unless disturbed or problematic.

**Restrictive Layer (if present):**

Type: \_\_\_\_\_  
 Depth (inches): \_\_\_\_\_

**Hydric Soils Present?**      Yes        No   

Remarks:

**HYDROLOGY**

**Wetland Hydrology Indicators:**

Primary Indicators (minimum of one required; check all that apply)

- Surface Water (A1)
- High Water Table (A2)
- Saturation (A3)
- Water Marks (B1)
- Sediment Deposits (B2)
- Drift Deposits (B3)
- Algal Mat or Crust (B4)
- Iron Deposits (B5)
- Surface Soil Cracks (B6)
- Inundation Visible on Aerial Imagery (B7)
- Sparsely Vegetated Concave Surface (B8)
- Water-Stained Leaves (B9) **(except MLRA 1, 2, 4A, and 4B)**
- Salt Crust (B11)
- Aquatic Invertebrates (B13)
- Hydrogen Sulfide Odor (C1)
- Oxidized Rhizospheres along Living Roots (C3)
- Presence of Reduced Iron (C4)
- Recent Iron Reduction in Tilled Soils (C6)
- Stunted or Stresses Plants (D1) **(LRR A)**
- Other (Explain in Remarks)

Secondary Indicators (2 or more required)

- Water-Stained Leaves (B9) **(MLRA 1, 2, 4A, and 4B)**
- Drainage Patterns (B10)
- Dry-Season Water Table (C2)
- Saturation Visible on Aerial Imagery (C9)
- Geomorphic Position (D2)
- Shallow Aquitard (D3)
- FAC-Neutral Test (D5)
- Raised Ant Mounds (D6) **(LRR A)**
- Frost-Heave Hummocks (D7)

**Field Observations:**

Surface Water Present?    Yes        No        Depth (inches): \_\_\_\_\_  
 Water Table Present?    Yes        No        Depth (inches): 15"  
 Saturation Present?  
 (includes capillary fringe)    Yes        No        Depth (inches): 10"

**Wetland Hydrology Present?**      Yes        No   

Describe Recorded Data (stream gauge, monitoring well, aerial photos, previous inspections), if available:

Remarks:

~5' into upland at A-4

**WETLAND DETERMINATION DATA FORM – Western Mountains, Valleys, and Coast Region**

Project Site: Parcel: 042507-9017 City/County: King County/ Sampling Date: 10-7-20  
 Applicant/Owner: Gaisford State: WA Sampling Point: DP#2  
 Investigator(s): John Altmann Section, Township, Range: S4, T25, 7E  
 Landform (hillslope, terrace, etc.): \_\_\_\_\_ Local relief (concave, convex, none): \_\_\_\_\_ Slope (%): \_\_\_\_\_  
 Subregion (LRR): A Lat: 47.67799 Long: -121.90886 Datum: \_\_\_\_\_  
 Soil Map Unit Name: 157 NWI classification: N/A  
 Are climatic / hydrologic conditions on the site typical for this time of year? Yes  No  (If no, explain in Remarks.)  
 Are Vegetation , Soil , or Hydrology , significantly disturbed? Are "Normal Circumstances" present? Yes  No   
 Are Vegetation , Soil , or Hydrology , naturally problematic? (If needed, explain any answers in Remarks.)

**SUMMARY OF FINDINGS – Attach site map showing sampling point locations, transects, important features, etc.**

Hydrophytic Vegetation Present?	Yes <input checked="" type="checkbox"/>	No <input type="checkbox"/>	<b>Is the Sampled Area within a Wetland?</b>	Yes <input type="checkbox"/>	No <input checked="" type="checkbox"/>
Hydric Soil Present?	Yes <input type="checkbox"/>	No <input checked="" type="checkbox"/>		Yes <input type="checkbox"/>	No <input checked="" type="checkbox"/>
Wetland Hydrology Present?	Yes <input type="checkbox"/>	No <input checked="" type="checkbox"/>		Yes <input type="checkbox"/>	No <input checked="" type="checkbox"/>
Remarks: Located 5' into upland off of A-4					

**VEGETATION – Use scientific names of plants**

Tree Stratum (Plot size: _____)	Absolute % Cover	Dominant Species?	Indicator Status	Dominance Test Worksheet:	
1. _____	_____	_____	_____	Number of Dominant Species That Are OBL, FACW, or FAC:	3 (A)
2. _____	_____	_____	_____	Total Number of Dominant Species Across All Strata:	3 (B)
3. _____	_____	_____	_____	Percent of Dominant Species That Are OBL, FACW, or FAC:	100 (A/B)
4. _____	_____	_____	_____		
50% = _____, 20% = _____	_____	= Total Cover			
<b>Sapling/Shrub Stratum (Plot size: 5')</b>					
1. <u>Rubus armeniacus</u>	90	yes	FAC	<b>Prevalence Index worksheet:</b>	
2. _____	_____	_____	_____	<u>Total % Cover of:</u>	
3. _____	_____	_____	_____	OBL species _____	x1 = _____
4. _____	_____	_____	_____	FACW species _____	x2 = _____
5. _____	_____	_____	_____	FAC species _____	x3 = _____
50% = 45, 20% = 18	90	= Total Cover		FACU species _____	x4 = _____
Herb Stratum (Plot size: 5')					
1. <u>Phalaris arundinacea</u>	20	yes	FACW	UPL species _____	x5 = _____
2. <u>Urtica dioica</u>	20	yes	FAC	Column Totals: _____ (A)	_____ (B)
3. <u>Conium maculatum</u>	10	yes	FAC	Prevalence Index = B/A = _____	
4. _____	_____	_____	_____	<b>Hydrophytic Vegetation Indicators:</b>	
5. _____	_____	_____	_____	<input type="checkbox"/> 1 – Rapid Test for Hydrophytic Vegetation	
6. _____	_____	_____	_____	<input checked="" type="checkbox"/> 2 - Dominance Test is >50%	
7. _____	_____	_____	_____	<input type="checkbox"/> 3 - Prevalence Index is ≤3.0 <sup>1</sup>	
8. _____	_____	_____	_____	<input type="checkbox"/> 4 - Morphological Adaptations <sup>1</sup> (Provide supporting data in Remarks or on a separate sheet)	
9. _____	_____	_____	_____	<input type="checkbox"/> 5 - Wetland Non-Vascular Plants <sup>1</sup>	
10. _____	_____	_____	_____	<input type="checkbox"/> Problematic Hydrophytic Vegetation <sup>1</sup> (Explain)	
11. _____	_____	_____	_____	<sup>1</sup> Indicators of hydric soil and wetland hydrology must be present, unless disturbed or problematic.	
50% = 25, 20% = 10	50	= Total Cover			
<b>Woody Vine Stratum (Plot size: _____)</b>					
1. _____	_____	_____	_____	<b>Hydrophytic Vegetation Present?</b>	
2. _____	_____	_____	_____	Yes <input type="checkbox"/>	No <input type="checkbox"/>
50% = _____, 20% = _____	_____	= Total Cover			
% Bare Ground in Herb Stratum _____					

Remarks:

**SOIL**

Sampling Point: DP#2

**Profile Description: (Describe to the depth needed to document the indicator or confirm the absence of indicators.)**

Depth (inches)	Matrix		Redox Features				Texture	Remarks
	Color (moist)	%	Color (moist)	%	Type <sup>1</sup>	Loc <sup>2</sup>		
_____	_____	_____	_____	_____	_____	_____	_____	_____
_____	_____	_____	_____	_____	_____	_____	_____	_____
_____	_____	_____	_____	_____	_____	_____	_____	_____
_____	_____	_____	_____	_____	_____	_____	_____	_____
_____	_____	_____	_____	_____	_____	_____	_____	_____
_____	_____	_____	_____	_____	_____	_____	_____	_____
_____	_____	_____	_____	_____	_____	_____	_____	_____
_____	_____	_____	_____	_____	_____	_____	_____	_____

<sup>1</sup>Type: C= Concentration, D=Depletion, RM=Reduced Matrix, CS=Covered or Coated Sand Grains.      <sup>2</sup>Location: PL=Pore Lining, M=Matrix

**Hydric Soil Indicators: (Applicable to all LRRs, unless otherwise noted.)**

- Histosol (A1)
- Histic Epipedon (A2)
- Black Histic (A3)
- Hydrogen Sulfide (A4)
- Depleted Below Dark Surface (A11)
- Thick Dark Surface (A12)
- Sandy Mucky Mineral (S1)
- Sandy Gleyed Matrix (S4)

- Sandy Redox (S5)
- Stripped Matrix (S6)
- Loamy Mucky Mineral (F1) **(except MLRA 1)**
- Loamy Gleyed Matrix (F2)
- Depleted Matrix (F3)
- Redox Dark Surface (F6)
- Depleted Dark Surface (F7)
- Redox Depressions (F8)

**Indicators for Problematic Hydric Soils<sup>3</sup>:**

- 2 cm Muck (A10)
- Red Parent Material (TF2)
- Very Shallow Dark Surface (TF12)
- Other (Explain in Remarks)

<sup>3</sup>Indicators of hydrophytic vegetation and wetland hydrology must be present, unless disturbed or problematic.

**Restrictive Layer (if present):**

Type: \_\_\_\_\_  
 Depth (inches): \_\_\_\_\_

**Hydric Soils Present?**      Yes      No  

Remarks:    Soil made up of fill material and woody debris

**HYDROLOGY**

**Wetland Hydrology Indicators:**

Primary Indicators (minimum of one required; check all that apply)

- Surface Water (A1)
- High Water Table (A2)
- Saturation (A3)
- Water Marks (B1)
- Sediment Deposits (B2)
- Drift Deposits (B3)
- Algal Mat or Crust (B4)
- Iron Deposits (B5)
- Surface Soil Cracks (B6)
- Inundation Visible on Aerial Imagery (B7)
- Sparsely Vegetated Concave Surface (B8)
- Water-Stained Leaves (B9) **(except MLRA 1, 2, 4A, and 4B)**
- Salt Crust (B11)
- Aquatic Invertebrates (B13)
- Hydrogen Sulfide Odor (C1)
- Oxidized Rhizospheres along Living Roots (C3)
- Presence of Reduced Iron (C4)
- Recent Iron Reduction in Tilled Soils (C6)
- Stunted or Stresses Plants (D1) **(LRR A)**
- Other (Explain in Remarks)

Secondary Indicators (2 or more required)

- Water-Stained Leaves (B9) **(MLRA 1, 2, 4A, and 4B)**
- Drainage Patterns (B10)
- Dry-Season Water Table (C2)
- Saturation Visible on Aerial Imagery (C9)
- Geomorphic Position (D2)
- Shallow Aquitard (D3)
- FAC-Neutral Test (D5)
- Raised Ant Mounds (D6) **(LRR A)**
- Frost-Heave Hummocks (D7)

**Field Observations:**

Surface Water Present?    Yes      No       Depth (inches): \_\_\_\_\_  
 Water Table Present?    Yes      No       Depth (inches): \_\_\_\_\_  
 Saturation Present?  
 (includes capillary fringe)    Yes      No       Depth (inches): \_\_\_\_\_

**Wetland Hydrology Present?**      Yes      No  

Describe Recorded Data (stream gauge, monitoring well, aerial photos, previous inspections), if available:

Remarks:    Dry

# **ATTACHMENT B**

# **WETLAND RATING**



# RATING SUMMARY – Western Washington

Name of wetland (or ID #): Parcel 042507-9017 Date of site visit: 10/7/2020

Rated by Altmann Trained by Ecology?  Yes  No Date of training 03/08 & 03/15

HGM Class used for rating Depressional & Flats Wetland has multiple HGM classes?  Yes  No

**NOTE: Form is not complete with out the figures requested (figures can be combined).**  
 Source of base aerial photo/map King County iMAP

**OVERALL WETLAND CATEGORY** III (based on functions  or special characteristics )

**1. Category of wetland based on FUNCTIONS**

- Category I - Total score = 23 - 27
- Category II - Total score = 20 - 22
- X   Category III - Total score = 16 - 19
- Category IV - Total score = 9 - 15

**Score for each function based on three ratings**  
 (order of ratings is not important)

9 = H, H, H  
 8 = H, H, M  
 7 = H, H, L  
 7 = H, M, M  
 6 = H, M, L  
 6 = M, M, M  
 5 = H, L, L  
 5 = M, M, L  
 4 = M, L, L  
 3 = L, L, L

FUNCTION	Improving Water Quality	Hydrologic	Habitat	
<i>List appropriate rating (H, M, L)</i>				
Site Potential	M	M	L	
Landscape Potential	M	M	M	
Value	H	H	M	<b>Total</b>
<b>Score Based on Ratings</b>	7	7	5	<b>19</b>

**2. Category based on SPECIAL CHARACTERISTICS of wetland**

CHARACTERISTIC	Category
Estuarine	
Wetland of High Conservation Value	
Bog	
Mature Forest	
Old Growth Forest	
Coastal Lagoon	
Interdunal	
None of the above	<b>X</b>

**DEPRESSIONAL AND FLATS WETLANDS****Water Quality Functions** - Indicators that the site functions to improve water quality

<b>D 1.0. Does the site have the potential to improve water quality?</b>		
<b>D 1.1. Characteristics of surface water outflows from the wetland:</b>		
Wetland is a depression or flat depression (QUESTION 7 on key) with no surface water leaving it (no outlet).	points = 3	3
Wetland has an intermittently flowing stream or ditch, OR highly constricted permanently flowing outlet.	points = 2	
<input type="checkbox"/> Wetland has an unconstricted, or slightly constricted, surface outlet that is permanently flowing	points = 1	
<input type="checkbox"/> Wetland is a flat depression (QUESTION 7 on key), whose outlet is a permanently flowing ditch.	points = 1	
<b>D 1.2. The soil 2 in below the surface (or duff layer) is true clay or true organic (use NRCS definitions).</b>	Yes = 4 No = 0	0
<b>D 1.3. Characteristics and distribution of persistent plants (Emergent, Scrub-shrub, and/or Forested Cowardin classes):</b>		
Wetland has persistent, ungrazed, plants > 95% of area	points = 5	5
Wetland has persistent, ungrazed, plants > 1/2 of area	points = 3	
Wetland has persistent, ungrazed plants > 1/10 of area	points = 1	
Wetland has persistent, ungrazed plants < 1/10 of area	points = 0	
<b>D 1.4. Characteristics of seasonal ponding or inundation:</b>		
<i>This is the area that is ponded for at least 2 months. See description in manual.</i>		
Area seasonally ponded is > 1/2 total area of wetland	points = 4	0
Area seasonally ponded is > 1/4 total area of wetland	points = 2	
Area seasonally ponded is < 1/4 total area of wetland	points = 0	
<b>Total for D 1</b>	<b>Add the points in the boxes above</b>	<b>8</b>

**Rating of Site Potential** If score is:  12 - 16 = H  6 - 11 = M  0 - 5 = L Record the rating on the first page

<b>D 2.0. Does the landscape have the potential to support the water quality function of the site?</b>		
<b>D 2.1. Does the wetland unit receive stormwater discharges?</b>	Yes = 1 No = 0	0
<b>D 2.2. Is &gt; 10% of the area within 150 ft of the wetland in land uses that generate pollutants?</b>	Yes = 1 No = 0	1
<b>D 2.3. Are there septic systems within 250 ft of the wetland?</b>	Yes = 1 No = 0	0
<b>D 2.4. Are there other sources of pollutants coming into the wetland that are not listed in questions D 2.1 - D 2.3?</b>		0
Source	Yes = 1 No = 0	
<b>Total for D 2</b>	<b>Add the points in the boxes above</b>	<b>1</b>

**Rating of Landscape Potential** If score is:  3 or 4 = H  1 or 2 = M  0 = L Record the rating on the first page

<b>D 3.0. Is the water quality improvement provided by the site valuable to society?</b>		
<b>D 3.1. Does the wetland discharge directly (i.e., within 1 mi) to a stream, river, lake, or marine water that is on the 303(d) list?</b>	Yes = 1 No = 0	0
<b>D 3.2. Is the wetland in a basin or sub-basin where an aquatic resource is on the 303(d) list?</b>	Yes = 1 No = 0	1
<b>D 3.3. Has the site been identified in a watershed or local plan as important for maintaining water quality (answer YES if there is a TMDL for the basin in which the unit is found)?</b>	Yes = 2 No = 0	2
<b>Total for D 3</b>	<b>Add the points in the boxes above</b>	<b>3</b>

**Rating of Value** If score is:  2 - 4 = H  1 = M  0 = L Record the rating on the first page

**DEPRESSIONAL AND FLATS WETLANDS****Hydrologic Functions** - Indicators that the site functions to reduce flooding and stream degradation

<b>D 4.0. Does the site have the potential to reduce flooding and erosion?</b>		
<b>D 4.1. Characteristics of surface water outflows from the wetland:</b>		
Wetland is a depression or flat depression with no surface water leaving it (no outlet)	points = 4	4
Wetland has an intermittently flowing stream or ditch, OR highly constricted permanently flowing outlet	points = 2	
Wetland is a flat depression (QUESTION 7 on key), whose outlet is a permanently flowing ditch	points = 1	
Wetland has an unconstricted, or slightly constricted, surface outlet that is permanently flowing	points = 0	
<b>D 4.2. Depth of storage during wet periods: <i>Estimate the height of ponding above the bottom of the outlet. For wetlands with no outlet, measure from the surface of permanent water or if dry, the deepest part.</i></b>		
Marks of ponding are 3 ft or more above the surface or bottom of outlet	points = 7	0
Marks of ponding between 2 ft to < 3 ft from surface or bottom of outlet	points = 5	
<input type="checkbox"/> Marks are at least 0.5 ft to < 2 ft from surface or bottom of outlet	points = 3	
<input type="checkbox"/> The wetland is a "headwater" wetland	points = 3	
Wetland is flat but has small depressions on the surface that trap water	points = 1	
Marks of ponding less than 0.5 ft (6 in)	points = 0	
<b>D 4.3. Contribution of the wetland to storage in the watershed: <i>Estimate the ratio of the area of upstream basin contributing surface water to the wetland to the area of the wetland unit itself.</i></b>		
<input type="checkbox"/> The area of the basin is less than 10 times the area of the unit	points = 5	5
The area of the basin is 10 to 100 times the area of the unit	points = 3	
The area of the basin is more than 100 times the area of the unit	points = 0	
<input type="checkbox"/> Entire wetland is in the Flats class	points = 5	
<b>Total for D 4</b>	<b>Add the points in the boxes above</b>	<b>9</b>

**Rating of Site Potential** If score is:  12 - 16 = H  6 - 11 = M  0 - 5 = L Record the rating on the first page

<b>D 5.0. Does the landscape have the potential to support hydrologic function of the site?</b>		
<b>D 5.1. Does the wetland unit receive stormwater discharges?</b>	Yes = 1 No = 0	0
<b>D 5.2. Is &gt; 10% of the area within 150 ft of the wetland in land uses that generate excess runoff?</b>	Yes = 1 No = 0	1
<b>D 5.3. Is more than 25% of the contributing basin of the wetland covered with intensive human land uses (residential at &gt;1 residence/ac, urban, commercial, agriculture, etc.)?</b>	Yes = 1 No = 0	1
<b>Total for D 5</b>	<b>Add the points in the boxes above</b>	<b>2</b>

**Rating of Landscape Potential** If score is:  3 = H  1 or 2 = M  0 = L Record the rating on the first page

<b>D 6.0. Are the hydrologic functions provided by the site valuable to society?</b>		
<b>D 6.1. The unit is in a landscape that has flooding problems. Choose the description that best matches conditions around the wetland unit being rated. Do not add points. Choose the highest score if more than one condition is met.</b>		
The wetland captures surface water that would otherwise flow down-gradient into areas where flooding has damaged human or natural resources (e.g., houses or salmon redds):		1
<input type="checkbox"/> • Flooding occurs in a sub-basin that is immediately down-gradient of unit.	points = 2	
<input type="checkbox"/> • Surface flooding problems are in a sub-basin farther down-gradient.	points = 1	
<input type="checkbox"/> Flooding from groundwater is an issue in the sub-basin.	points = 1	
<input type="checkbox"/> The existing or potential outflow from the wetland is so constrained by human or natural conditions that the water stored by the wetland cannot reach areas that flood. Explain why	points = 0	
<input type="checkbox"/> There are no problems with flooding downstream of the wetland.	points = 0	
<b>D 6.2. Has the site been identified as important for flood storage or flood conveyance in a regional flood control plan?</b>	Yes = 2 No = 0	0
<b>Total for D 6</b>	<b>Add the points in the boxes above</b>	<b>1</b>

**Rating of Value** If score is:  2 - 4 = H  1 = M  0 = L Record the rating on the first page

**These questions apply to wetlands of all HGM classes.**

**HABITAT FUNCTIONS** - Indicators that site functions to provide important habitat

H 1.0. Does the site have the potential to provide habitat?

H 1.1. Structure of plant community: *Indicators are Cowardin classes and strata within the Forested class. Check the Cowardin plant classes in the wetland. Up to 10 patches may be combined for each class to meet the threshold of ¼ ac or more than 10% of the unit if it is smaller than 2.5 ac. Add the number of structures checked.*

- Aquatic bed 4 structures or more: points = 4
  - Emergent 3 structures: points = 2
  - Scrub-shrub (areas where shrubs have > 30% cover) 2 structures: points = 1
  - Forested (areas where trees have > 30% cover) 1 structure: points = 0
- If the unit has a Forested class, check if:*
- The Forested class has 3 out of 5 strata (canopy, sub-canopy, shrubs, herbaceous, moss/ground-cover) that each cover 20% within the Forested polygon

0

H 1.2. Hydroperiods

Check the types of water regimes (hydroperiods) present within the wetland. The water regime has to cover more than 10% of the wetland or ¼ ac to count (*see text for descriptions of hydroperiods*).

- Permanently flooded or inundated 4 or more types present: points = 3
- Seasonally flooded or inundated 3 types present: points = 2
- Occasionally flooded or inundated 2 types present: points = 1
- Saturated only 1 types present: points = 0
- Permanently flowing stream or river in, or adjacent to, the wetland
- Seasonally flowing stream in, or adjacent to, the wetland
- Lake Fringe wetland** **2 points**
- Freshwater tidal wetland** **2 points**

0

H 1.3. Richness of plant species

Count the number of plant species in the wetland that cover at least 10 ft<sup>2</sup>. *Different patches of the same species can be combined to meet the size threshold and you do not have to name the species. Do not include Eurasian milfoil, reed canarygrass, purple loosestrife, Canadian thistle*

- If you counted:
- > 19 species points = 2
  - 5 - 19 species points = 1
  - < 5 species points = 0

0

H 1.4. Interspersion of habitats

Decide from the diagrams below whether interspersions among Cowardin plants classes (described in H 1.1), or the classes and unvegetated areas (can include open water or mudflats) is high, moderate, low, or none. *If you have four or more plant classes or three classes and open water, the rating is always high.*



**None** = 0 points

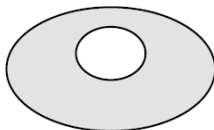

**Low** = 1 point



**Moderate** = 2 points

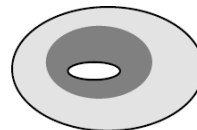

0

All three diagrams in this row are **HIGH** = 3 points

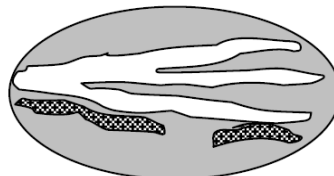
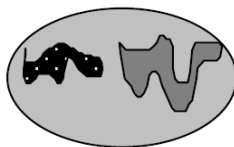

<b>H 1.5. Special habitat features:</b> Check the habitat features that are present in the wetland. <i>The number of checks is the number of points.</i>			
<input checked="" type="checkbox"/> Large, downed, woody debris within the wetland (> 4 in diameter and 6 ft long) <input type="checkbox"/> Standing snags (dbh > 4 in) within the wetland <input type="checkbox"/> Undercut banks are present for at least 6.6 ft (2 m) <b>and/or</b> overhanging plants extends at least 3.3 ft (1 m) over a stream (or ditch) in, or contiguous with the wetland, for at least 33 ft (10 m) <input type="checkbox"/> Stable steep banks of fine material that might be used by beaver or muskrat for denning (> 30 degree slope) OR signs of recent beaver activity are present ( <i>cut shrubs or trees that have not yet weathered where wood is exposed</i> ) <input type="checkbox"/> At least ¼ ac of thin-stemmed persistent plants or woody branches are present in areas that are permanently or seasonally inundated ( <i>structures for egg-laying by amphibians</i> ) <input type="checkbox"/> Invasive plants cover less than 25% of the wetland area in every stratum of plants (see H 1.1 for list of strata)		1	
<b>Total for H 1</b>		Add the points in the boxes above	1

**Rating of Site Potential** If Score is:  15 - 18 = H  7 - 14 = M  0 - 6 = L Record the rating on the first page

<b>H 2.0. Does the landscape have the potential to support the habitat function of the site?</b>			
<b>H 2.1 Accessible habitat (include <i>only habitat that directly abuts wetland unit</i>).</b> Calculate: 6.8 % undisturbed habitat + ( <u>2.7</u> % moderate & low intensity land uses / 2 ) = 8.15%			
If total accessible habitat is: > 1/3 (33.3%) of 1 km Polygon points = 3 20 - 33% of 1 km Polygon points = 2 10 - 19% of 1 km Polygon points = 1 < 10 % of 1 km Polygon points = 0		0	
<b>H 2.2. Undisturbed habitat in 1 km Polygon around the wetland.</b> Calculate: 44.4 % undisturbed habitat + ( <u>16.3</u> % moderate & low intensity land uses / 2 ) = 52.55%			
Undisturbed habitat > 50% of Polygon points = 3 Undisturbed habitat 10 - 50% and in 1-3 patches points = 2 Undisturbed habitat 10 - 50% and > 3 patches points = 1 Undisturbed habitat < 10% of 1 km Polygon points = 0		3	
<b>H 2.3 Land use intensity in 1 km Polygon: If</b> > 50% of 1 km Polygon is high intensity land use points = (-2) ≤ 50% of 1km Polygon is high intensity points = 0			
<b>Total for H 2</b>		Add the points in the boxes above	3

**Rating of Landscape Potential** If Score is:  4 - 6 = H  1 - 3 = M  < 1 = L Record the rating on the first page

<b>H 3.0. Is the habitat provided by the site valuable to society?</b>		
<b>H 3.1. Does the site provide habitat for species valued in laws, regulations, or policies? Choose <i>only the highest score that applies to the wetland being rated</i>.</b>		
Site meets ANY of the following criteria: points = 2 <input type="checkbox"/> It has 3 or more priority habitats within 100 m (see next page) <input type="checkbox"/> It provides habitat for Threatened or Endangered species (any plant or animal on the state or federal lists) <input type="checkbox"/> It is mapped as a location for an individual WDFW priority species <input type="checkbox"/> It is a Wetland of High Conservation Value as determined by the Department of Natural Resources <input type="checkbox"/> It has been categorized as an important habitat site in a local or regional comprehensive plan, in a Shoreline Master Plan, or in a watershed plan		1
Site has 1 or 2 priority habitats (listed on next page) with in 100m points = 1 Site does not meet any of the criteria above points = 0		

**Rating of Value** If Score is:  2 = H  1 = M  0 = L Record the rating on the first page

## WDFW Priority Habitats

Priority habitats listed by WDFW (see complete descriptions of WDFW priority habitats, and the counties in which they can be found, in: Washington Department of Fish and Wildlife. 2008. Priority Habitat and Species List. Olympia, Washington. 177 pp.

<http://wdfw.wa.gov/publications/00165/wdfw00165.pdf> or access the list from here:

<http://wdfw.wa.gov/conservation/phs/list/>







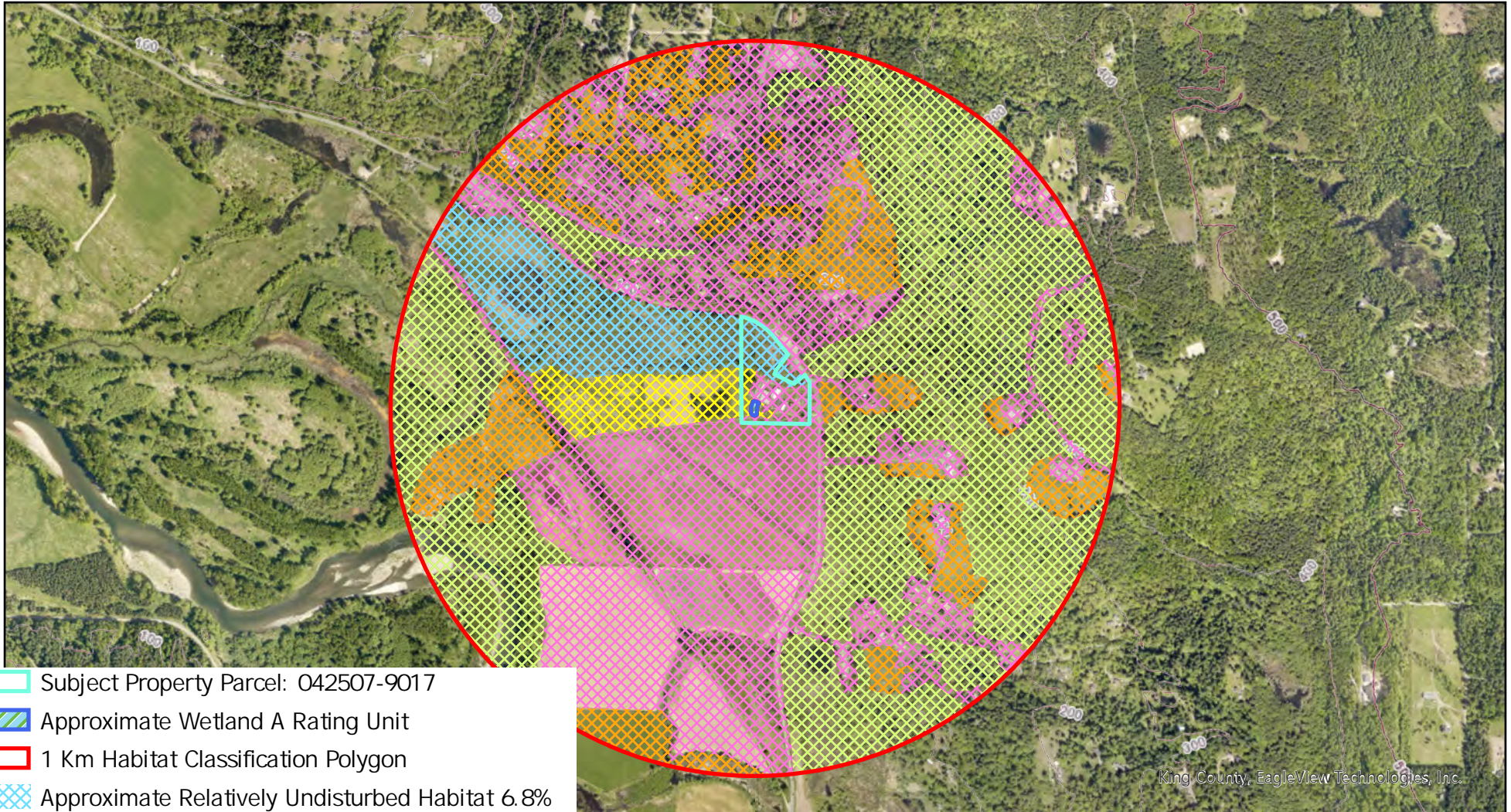

Count how many of the following priority habitats are within 330 ft (100 m) of the wetland unit: **NOTE:** *This question is independent of the land use between the wetland unit and the priority habitat.*

- Aspen Stands:** Pure or mixed stands of aspen greater than 1 ac (0.4 ha).
- Biodiversity Areas and Corridors:** Areas of habitat that are relatively important to various species of native fish and wildlife (*full descriptions in WDFW PHS report*).
- Herbaceous Balds:** Variable size patches of grass and forbs on shallow soils over bedrock.
- Old-growth/Mature forests:** Old-growth west of Cascade crest – Stands of at least 2 tree species, forming a multi-layered canopy with occasional small openings; with at least 8 trees/ac (20 trees/ha) > 32 in (81 cm) dbh or > 200 years of age. Mature forests – Stands with average diameters exceeding 21 in (53 cm) dbh; crown cover may be less than 100%; decay, decadence, numbers of snags, and quantity of large downed material is generally less than that found in old-growth; 80-200 years old west of the Cascade crest.
- Oregon White Oak:** Woodland stands of pure oak or oak/conifer associations where canopy coverage of the oak component is important (*full descriptions in WDFW PHS report p. 158 – see web link above*).
- Riparian:** The area adjacent to aquatic systems with flowing water that contains elements of both aquatic and terrestrial ecosystems which mutually influence each other.
- Westside Prairies:** Herbaceous, non-forested plant communities that can either take the form of a dry prairie or a wet prairie (*full descriptions in WDFW PHS report p. 161 – see web link above*).
- Instream:** The combination of physical, biological, and chemical processes and conditions that interact to provide functional life history requirements for instream fish and wildlife resources.
- Nearshore:** Relatively undisturbed nearshore habitats. These include Coastal Nearshore, Open Coast Nearshore, and Puget Sound Nearshore. (*full descriptions of habitats and the definition of relatively undisturbed are in WDFW report – see web link on previous page*).
- Caves:** A naturally occurring cavity, recess, void, or system of interconnected passages under the earth in soils, rock, ice, or other geological formations and is large enough to contain a human.
- Cliffs:** Greater than 25 ft (7.6 m) high and occurring below 5000 ft elevation.
- Talus:** Homogenous areas of rock rubble ranging in average size 0.5 - 6.5 ft (0.15 - 2.0 m), composed of basalt, andesite, and/or sedimentary rock, including riprap slides and mine tailings. May be associated with cliffs.
- Snags and Logs:** Trees are considered snags if they are dead or dying and exhibit sufficient decay characteristics to enable cavity excavation/use by wildlife. Priority snags have a diameter at breast height of > 20 in (51 cm) in western Washington and are > 6.5 ft (2 m) in height. Priority logs are > 12 in (30 cm) in diameter at the largest end, and > 20 ft (6 m) long.

**Note:** All vegetated wetlands are by definition a priority habitat but are not included in this list because they are addressed elsewhere.

# Figure A



-  Subject Property Parcel: 042507-9017
-  Approximate Wetland A Rating Unit
-  1 Km Habitat Classification Polygon
-  Approximate Relatively Undisturbed Habitat 6.8%
-  Approximate Low\_Moderate Intensity Habitat 2.7%
-  Relatively Undisturbed Habitat 37.6%
-  Low\_Moderate Intensity Habitat 13.6%
-  High Intensity Habitat 39.3%

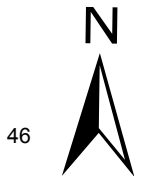
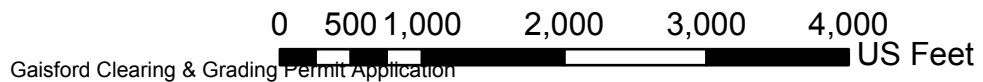

King County  
Parcel 042507-9017

# Figure B

AOA - 6309

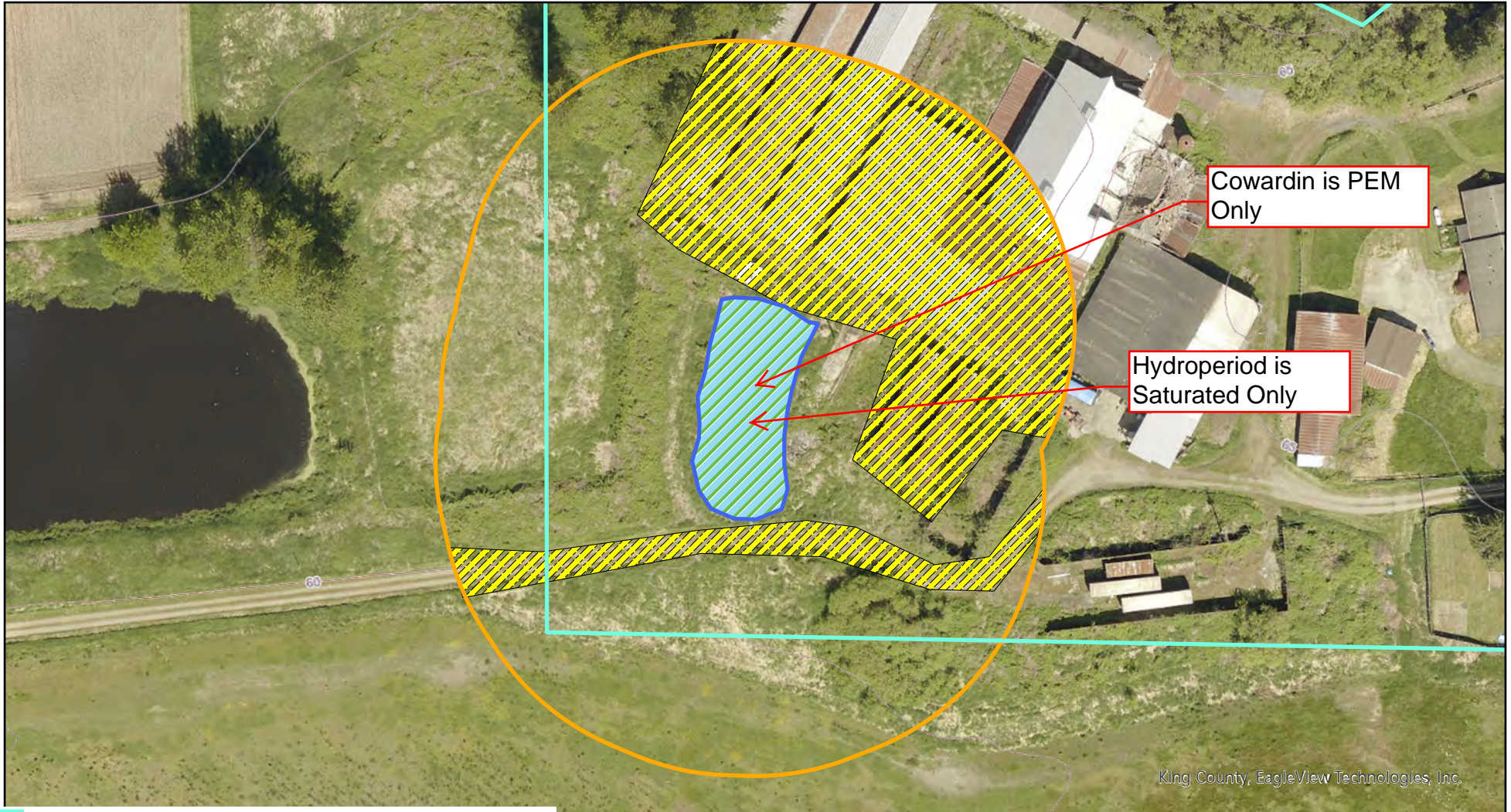

 Subject Property Parcel: 042507-9017

 Approximate Wetland A Rating Unit

 Approximate 150' Pollution Assessment Polygon

 Pollution Generating Surfaces 37.7%

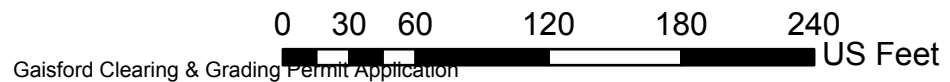

Gaisford Clearing & Grading Permit Application







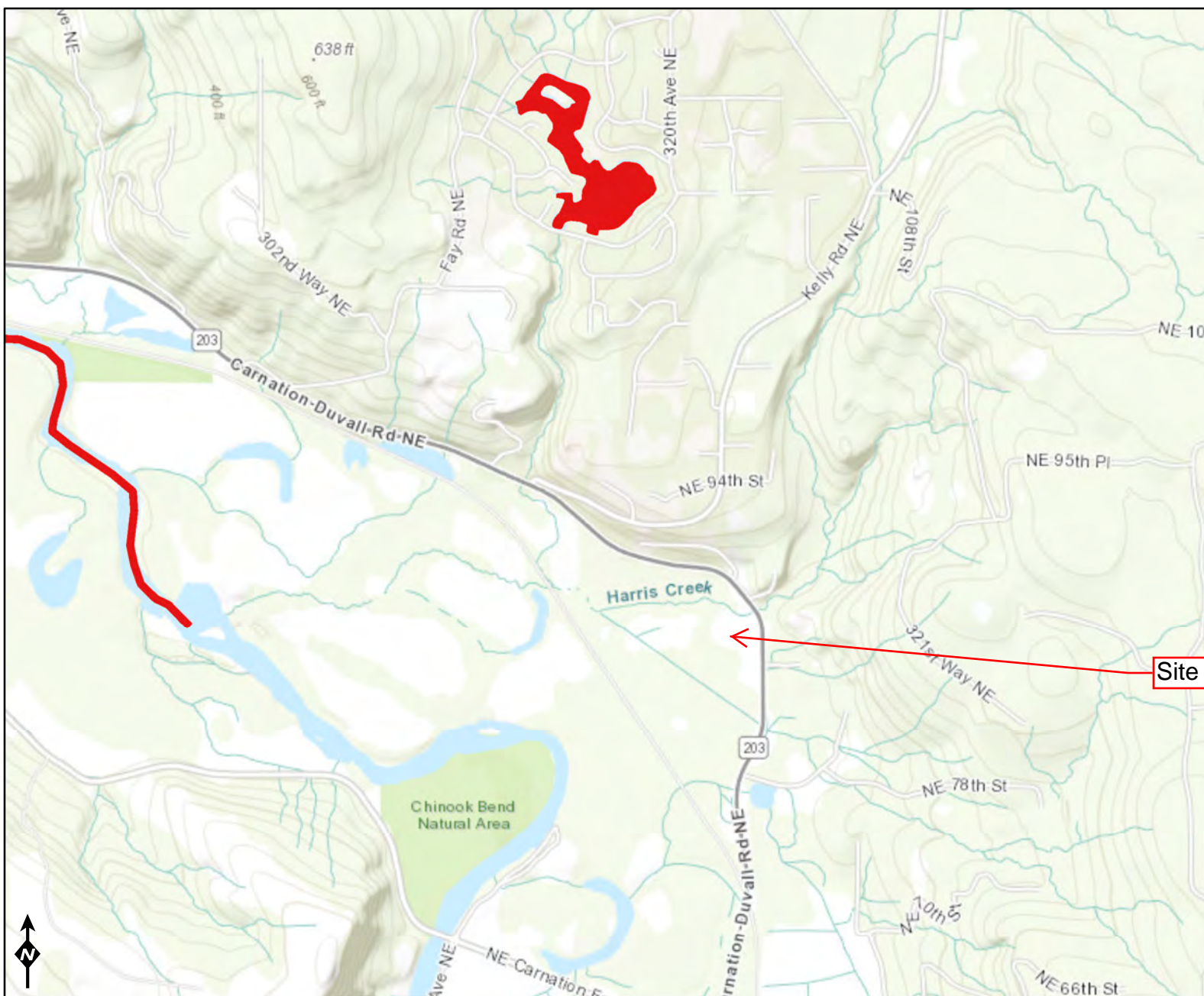



# Figure C







### Assessed Waters/Sediment

#### Water

-  Category 5 - 303d
-  Category 4C
-  Category 4B
-  Category 4A
-  Category 2
-  Category 1

#### Sediment

-  Category 5 - 303d
-  Category 4C
-  Category 4B
-  Category 4A
-  Category 2
-  Category 1

Site

Sources: Esri, HERE, Garmin, Intermap, increment P Corp., GEBCO, USGS, FAO, NPS, NRCAN, GeoBase, IGN, Kadaster NL, Ordnance Survey, Esri Japan, METI, Esri China (Hong Kong), (c) OpenStreetMap contributors, and

TIMESTAMPS

Water Quality Improvement Projects (TMDLs)

**WATER QUALITY IMPROVEMENT PROJECTS (TMDLs)**

Overview of the process

Project Catalog

- **by WRIA**
- **by County**

Funding Opportunities

Project Development Priority Lists

Related Information

TMDL Contacts

**RELATED ECOLOGY PROGRAMS**

Water Quality

[Water Quality Improvement](#) > [Water Quality Improvement Projects by WRIA](#) > WRIA 7: Snohomish

## WRIA 7: Snohomish

The following table lists overview information and links to specific water quality improvement projects (including total maximum daily loads, or TMDLs) for this water resource inventory area ([WRIA](#)). Please use links (where available) for more information on a project.

**Counties**

- [King](#)
- [Snohomish](#)

Waterbody Name	Pollutant(s)	Status**	TMDL Lead
<a href="#">Lake Loma</a>	Total Phosphorus	Straight to implementation project under development	<a href="#">Tricia Shoblom</a> 425-649-7288
<a href="#">Snohomish River</a>	<a href="#">French Creek / Pilchuck River</a> <ul style="list-style-type: none"> <li>• Dissolved Oxygen</li> <li>• Temperature</li> </ul>	Under development	<a href="#">Ralph Svrjcek</a> 425-649-7165
	<a href="#">Dioxin</a>	EPA approved	<a href="#">Ralph Svrjcek</a> 425-649-7165
	<a href="#">Estuary</a> <ul style="list-style-type: none"> <li>• Ammonia</li> <li>• BOD</li> </ul>	EPA approved	<a href="#">Ralph Svrjcek</a> 425-649-7165
	<a href="#">Tributaries</a> <ul style="list-style-type: none"> <li>• Fecal Coliform</li> </ul> Tributaries:	EPA approved	<a href="#">Ralph Svrjcek</a> 425-649-7165

	<ul style="list-style-type: none"> <li>• Allen Creek</li> <li>• Quilceda Creek</li> <li>• French Creek</li> <li>• Woods Creek</li> <li>• Pilchuck River</li> <li>• Marshlands (Wood Creek) {2}</li> </ul>		
	<u>Snoqualmie River</u> <ul style="list-style-type: none"> <li>• Ammonia-N</li> <li>• BOD (5-day)</li> <li>• Fecal Coliform</li> </ul> Temperature	EPA approved  EPA approved Has an implementation plan	<u>Ralph Svrjcek</u> 425-649-7165

**\*\* Status** will be listed as one of the following: *Approved by EPA, Under Development or Implementation*

**For more information about WRIA 7:**

- [Waterbodies in WRIA 7](#) - using the Water Quality Assessment Query Tool
- [Watershed Information for WRIA 7](#)

\* The Department of Ecology and other state resource agencies frequently use a system of 62 "Water Resource Inventory Areas" or "WRIAs" to refer to the state's major watershed basins.

[Back to top of page](#)

Last updated January 2014