

# King County Nitrogen Removal Study: Final Report

---

Prepared for  
King County  
Seattle, WA  
September 9, 2020

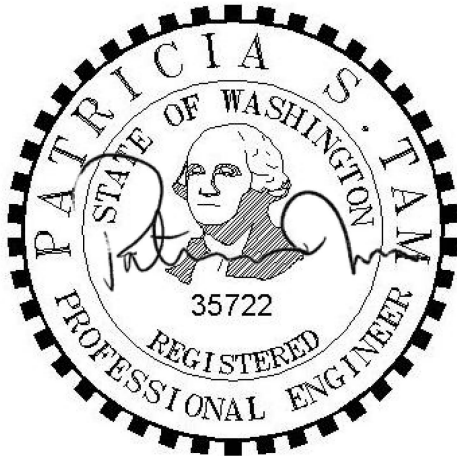

Prepared By: Patricia Tam  
Date: September 9, 2020

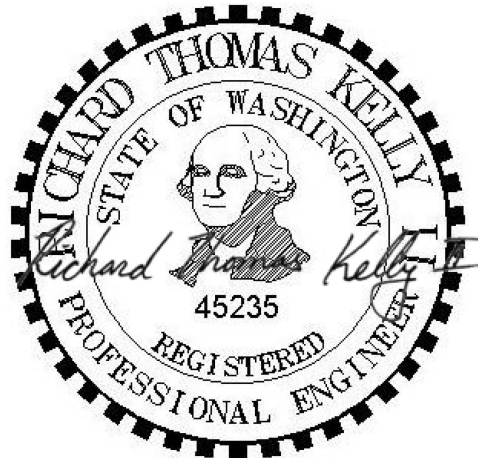

Reviewed By: Richard Kelly  
Date: September 9, 2020



701 Pike Street, Suite 1200  
Seattle, WA 98101

# Table of Contents

Table of Contents .....	ii
1. Introduction .....	1-1
1.1 Study Background .....	1-1
2. Study Approach .....	2-1
2.1 Nitrogen Removal Technology Categories .....	2-1
2.2 Approach Steps .....	2-2
2.3 Key Assumptions .....	2-2
3. West Point Treatment Plant .....	3-1
3.1 Pre-Screened Technologies .....	3-1
3.2 Nitrogen Removal Scenarios and Alternatives .....	3-1
3.3 Evaluation Results .....	3-3
3.4 Conclusions .....	3-5
4. South Treatment Plant .....	4-1
4.1 Pre-Screened Technologies .....	4-1
4.2 Nitrogen Removal Scenarios and Alternatives .....	4-1
4.3 Evaluation Results .....	4-3
4.4 Conclusions .....	4-5
5. Brightwater Treatment Plant .....	5-1
5.1 Pre-Screened Technologies .....	5-1
5.2 Nitrogen Removal Scenarios and Alternatives .....	5-1
5.3 Evaluation Results .....	5-3
5.4 Conclusions .....	5-5
6. Overall Conclusions .....	6-1
7. References .....	7-1
Appendix A: TM 1 .....	A-1
Appendix B: TM 2—West Point .....	B-1
Appendix C: TM 2—South Plant .....	C-1
Appendix D: TM 2—Brightwater .....	D-1
Appendix E: TM 3A—West Point .....	E-1
Appendix F: TM 3B—South Plant .....	F-1
Appendix G: TM 3C—Brightwater .....	G-1



## List of Figures

---

Figure 2-1. Nitrogen Removal Treatment Process Categories .....	2-1
Figure 3-1. Estimated GHG Emission Ranges for West Point Nitrogen Removal Scenarios.....	3-4
Figure 3-2. Comparison of Footprint Consumed for West Point Nitrogen Removal Scenarios.....	3-5
Figure 4-1. Estimated GHG Emission Ranges for South Plant Nitrogen Removal Scenarios .....	4-4
Figure 4-2. Comparison of Footprint Consumed for South Plant Nitrogen Removal Scenarios .....	4-5
Figure 5-1. Estimated GHG Emission Ranges for Brightwater Nitrogen Removal Scenarios .....	5-4
Figure 5-2. Comparison of Footprint Consumed for Brightwater Nitrogen Removal Scenarios .....	5-5
Figure 6-1. Total Project Cost Ranges for Different Nitrogen Removal Scenarios.....	6-3

## List of Tables

---

Table 3-1. Technologies Selected for Detailed Screening for West Point .....	3-1
Table 3-2. West Point Nitrogen Removal Scenarios and Alternatives .....	3-2
Table 3-3. Cost Estimate Ranges for West Point Nitrogen Removal Scenarios.....	3-3
Table 3-4. Operational Requirements for West Point Nitrogen Removal Scenarios .....	3-4
Table 4-1. Technologies Selected for Detailed Screening for South Plant.....	4-1
Table 4-2. South Plant Nitrogen Removal Scenarios and Alternatives .....	4-2
Table 4-3. Cost Estimate Ranges for South Plant Nitrogen Removal Scenarios .....	4-3
Table 4-4. Operational Requirements for South Plant Nitrogen Removal Scenarios.....	4-4
Table 5-1. Technologies Selected for Detailed Screening for Brightwater.....	5-1
Table 5-2. Brightwater Nitrogen Removal Scenarios and Alternatives.....	5-2
Table 5-3. Cost Estimate Ranges for Brightwater Nitrogen Removal Scenarios .....	5-3
Table 5-4. Operational Requirements for Brightwater Nitrogen Removal Scenarios.....	5-4

## List of Abbreviations

---

4SMB	four-stage modified Bardenpho
BOD	biochemical oxygen demand
BWABO	Brightwater Aeration Basin Optimization
CAS	conventional activated sludge
CECs	compounds of emerging concern
CEPT	chemically enhanced primary treatment
CO <sub>2</sub> e	carbon dioxide equivalent
DO	dissolved oxygen
Ecology	Washington State Department of Ecology
FTE	full-time equivalent
GHG	greenhouse gas
HPO	high-purity oxygen
lb	pound(s)
MBR	membrane bioreactor
M	million
mgd	million gallons per day
mg/L	milligrams per liter
MLE	modified Ludzack-Ettinger
MT	metric tons
MT/yr	metric tons per year
MWh	megawatt-hours
N	nitrogen
NEB	net environmental benefit
NPDES	National Pollutant Discharge Elimination System
NPV	net present value
NWEA	Northwest Environmental Advocates
PSNSRP	Puget Sound Nutrient Source Reduction Project
SND	simultaneous nitrification/denitrification
TIN	total inorganic nitrogen
TKN	total Kjeldahl nitrogen
US	Unites States
WTD	King County Wastewater Treatment Division
WWTP	wastewater treatment plant

This page intentionally left blank.



# 1. Introduction

This report summarizes the background, approach, and results of the King County Wastewater Treatment Division's (WTD) Nitrogen Removal Study. The purpose of the study was to identify appropriate nitrogen removal alternatives for the County's three regional wastewater treatment plants (WWTPs)—West Point Treatment Plant (West Point), South Treatment Plant (South Plant), and Brightwater Treatment Plant (Brightwater)—and to develop planning-level details for the feasible alternatives, including sizing, capital costs, operational costs and impacts, greenhouse gas (GHG) emissions, and risks. The Nitrogen Removal Study was done in parallel with potential regulatory changes for nitrogen discharges being considered by the Washington State Department of Ecology (Ecology). The results in this report are presented in the context of the regulatory changes for nitrogen discharges being considered by Ecology.

## 1.1 Study Background

Adequate concentrations of dissolved oxygen (DO) in surface water are critical for the survival of many aquatic species. Ecology has been studying impairment in Puget Sound and the Salish Sea since the late 1990s. Low DO conditions have been attributed, in part, to excess nitrogen loading into Puget Sound from anthropogenic sources, of which WWTPs represent the largest point source dischargers. DO concentrations vary seasonally and geographically within Puget Sound, and anthropogenic causes can further impair naturally low levels in certain areas, threatening aquatic wildlife populations in the region.

Over the past two decades, WTD has been exploring and assessing its treatment system capabilities for nitrogen removal. In 2003, WTD initiated the design of Brightwater with the goal of producing high-quality effluent discharge to Puget Sound and creating a potential reclaimed water supply, with the side benefit of full nitrification and partial denitrification due to the membrane bioreactor (MBR) treatment process that was installed. In 2010 and 2011, WTD completed planning-level alternatives analyses to assess the feasibility and upgrade requirements of South Plant and West Point for nitrogen removal (Carollo 2010, 2011). WTD has also trialed operational adjustments at South Plant in selected summer seasons since 2012 to achieve reduced nitrogen discharges to Puget Sound.

Simultaneous to WTD's work assessing its treatment system capabilities, Ecology was studying the impact of nutrient removal at wastewater facilities. Because of existing regulatory and permitting mechanisms, WWTPs and other point source dischargers are often the primary target for nutrient reductions. Ecology's study culminated in the report, "Technical and Economic Evaluation of Nitrogen and Phosphorus Removal at Municipal Wastewater Treatment Facilities" (Tetra Tech 2011), which evaluated generic costs and upgrade requirements for small, medium, and large facilities in Washington state to meet various levels of nutrient removal, including nitrogen removal in the Puget Sound region. The study also determined that West Point and South Plant are the two largest point sources of anthropogenic nitrogen in Puget Sound.

In 2009, Ecology developed the Puget Sound DO model to investigate the causes of low DO in the sound in parallel with the nutrient removal study they were completing. Then, in 2017, Ecology began the Puget Sound Nutrient Source Reduction Project (PSNSRP), which is a collaborative effort with communities and stakeholders to address anthropogenic nutrient sources entering Puget Sound. As part of the PSNSRP, Ecology initiated a more detailed DO model for the entire Salish Sea to investigate the benefits of reducing nitrogen. That same year, Ecology established the Puget Sound Nutrients Forum as an opportunity for interested parties and the public to learn about the

PSNSRP, consider the projected impacts of nutrients from the Salish Sea model, and discuss how to reduce human sources of nutrients.

In January 2019, Ecology published its initial modeling results in “Puget Sound Nutrient Source Reduction Project—Volume 1: Modeling Updates and Bounding Scenarios” (Ecology Publication No. 19-03-001). The report outlined the estimated benefits of implementing summer-only effluent nitrogen limits of 8 milligrams per liter (mg/L) total inorganic nitrogen (TIN) at 67 WWTPs discharging directly to Puget Sound or to nearby surface waters. The report includes WTD’s three regional treatment plants: West Point, South Plant, and Brightwater. Ecology has continued to update the model to look at additional scenarios, including lower seasonal TIN limits (from April through October, defined as the summer period in this study) and year-round TIN limits, and plans to use these scenarios to inform potential future permit limits.

Concurrent to the Salish Sea modeling and nutrient forums, in November 2018, Northwest Environmental Advocates (NWEA) filed a Petition for Rulemaking with Ecology requesting that Ecology revise Chapter 173-221 in the Washington Administrative Code to establish year-round total nitrogen and total phosphorus limits of 3.0 and 0.1 mg/L, respectively. The filing also requested that tertiary treatment be included within the definition of “all known, available, and reasonable methods of prevention, control, and treatment” for municipal wastewater treatment. In a response letter dated January 11, 2019, Ecology denied the petition from NWEA, but committed to implementing the following measures through the National Pollutant Discharge Elimination System (NPDES) permitting process:

- Set nutrient (i.e., nitrogen) loading limits at current levels for all permitted dischargers in Puget Sound.
- Require facilities to begin planning efforts to evaluate treatment implications of different nitrogen removal targets.
- For facilities that are already capable of nitrogen removal, amend their current NPDES permit to include limits commensurate with their treatment capability.

As a participant in the Puget Sound Nutrient Forum since the forum’s inception in 2017—during which Ecology identified nitrogen, not phosphorus, as the limiting nutrient in Puget Sound—WTD recognized the need to have an updated understanding of nitrogen reduction technologies, applicability, and costs for its three large, regional treatment plants. Because Ecology indicated they do not plan to regulate phosphorus discharge to Puget Sound at this time, in 2018 WTD initiated the Nitrogen Removal Study to conduct conceptual, planning-level alternatives analyses for its regional treatment plants focused on nitrogen removal only. The study incorporates updated information on potential nitrogen limits and new technology advancements since 2011, and serves as a starting point for planning efforts that will likely be required by Ecology.

## 2. Study Approach

The Nitrogen Removal Study identified and analyzed potential planning-level alternatives to achieve nitrogen removal at WTD's three regional treatment plants. WTD conducted the study with consultant support from Brown and Caldwell and cross-divisional participation by WTD staff in operations, engineering, modeling, planning, environmental services, and resource recovery.

### 2.1 Nitrogen Removal Technology Categories

Before describing the evaluation approach, it is important to understand how the various nitrogen removal treatment technologies are categorized. The categories are generally related to how each technology fits into the treatment processes at a WWTP. Figure 2-1 illustrates nitrogen removal treatment process categories in a sample process flow diagram. Brief descriptions of these categories are also given below the figure.

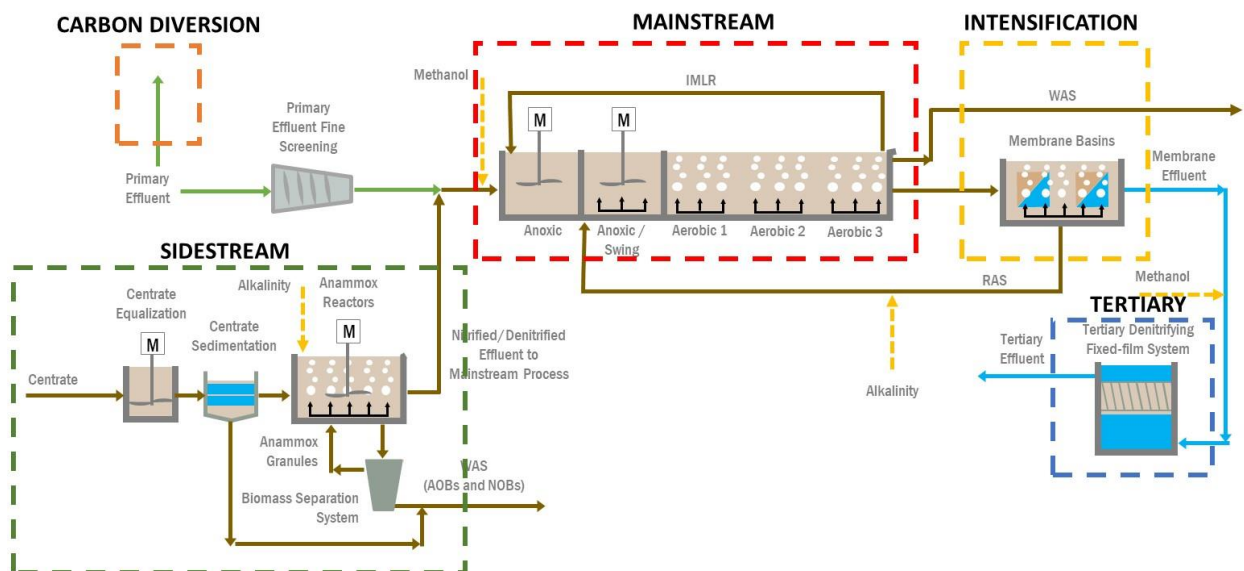

Figure 2-1. Nitrogen Removal Treatment Process Categories

- **Mainstream treatment technologies:** Used as the mainstream biological secondary treatment process and must be capable of nitrogen removal.
- **Sidestream treatment technologies:** Implemented only on plant solids dewatering streams. These technologies can remove nitrogen from these streams or be used to nitrify these streams and seed nitrifying organisms back to the main process to shorten required mainstream solids retention time. These technologies can be implemented as stand-alone nitrogen removal technologies to promote modest effluent nitrogen reductions.
- **Tertiary treatment technologies:** Used after biological secondary treatment to nitrify and denitrify plant effluent prior to discharge.
- **Intensification technologies:** Enable mainstream treatment processes to operate in a smaller footprint. They do not necessarily remove nitrogen directly, but are used in conjunction with a nitrogen removal mainstream or tertiary treatment process.

- **Carbon diversion technologies:** Enhance biochemical oxygen demand (BOD) removal from influent wastewater before secondary treatment. This allows for operating secondary treatment processes in a smaller footprint (due to reduced biomass growth) with less energy (due to diverting BOD away from aerobic processes) to accommodate for nitrogen removal. These technologies also put additional solids into digestion processes and can allow for additional biogas generation for resource recovery or reuse.

## 2.2 Approach Steps

The following steps were used to screen and evaluate the planning-level alternatives at each of WTD's three regional treatment plants:

1. **Technology Screening:** The project team first identified, reviewed, and categorized an exhaustive list of nitrogen removal technologies. Initial screening criteria were then developed and used to eliminate technologies that are not currently applicable for WTD's treatment plants, resulting in a list of about eight to 10 candidate technologies for each plant that advanced to subsequent steps.
2. **Nitrogen Removal Scenario Development:** Nitrogen removal scenarios were established for each plant to provide performance targets for the alternatives. These scenarios range from a relatively low level of removal, but also low cost of implementation by adding sidestream treatment only, to a seasonal TIN limit, to a low year-round TIN limit. This approach provided a range of costs, footprints, GHG emissions, and operational impacts corresponding to each level of nitrogen removal.
3. **Technology Combination Screening:** The pre-screened technologies from Step 1 were grouped into technology combinations and evaluated using screening criteria similar to those used for the initial technology screening evaluation. These combinations included either a single technology from one process category or multiple technologies combined from various categories. The technology combinations were ranked as alternatives for each plant and scenario developed under Step 2. The top two to four highest-ranked alternatives for each scenario were evaluated in the site-specific analysis for each plant.
4. **Site-Specific Analysis:** The highest ranked alternatives for each plant from Step 3 were evaluated to develop conceptual site layouts, capital costs, operating costs, life cycle costs, anticipated treatment performance, estimated biosolids production, and GHG emissions. Sizing for new and expanded treatment processes was done using previously calibrated biological process simulator models. Evaluation criteria were developed and used to compare alternatives in workshop settings with WTD staff. The evaluation results were used to represent the range of potential costs and other factors for each scenario.

## 2.3 Key Assumptions

Numerous assumptions were made to complete the nitrogen removal study. The technical memoranda in this report's appendices provide details of these assumptions. The following are key assumptions that are common among WTD's three plants:

- All modeling and sizing conducted for this study were based on the current-rated capacity for each plant. This demonstrates the additional costs of performing nitrogen removal relative to existing plant conditions and capacities. Further evaluation would be needed to assess outcomes of nitrogen removal implementation at projected future flows and loads.
- The nitrogen effluent limits explored in this study are based on the best information available for potential permit requirements at the time this study was initiated.



- For scenarios with a seasonal nitrogen limit, the limit was assumed to apply between April and October. April is considered the critical month for facility sizing because of the low wastewater temperature typically observed in that month and the potential for peak flows to occur, both of which impact the nitrification process.
- Nitrogen removal efforts have been expanding industry-wide in recent years and new technologies are entering the market, with some rapidly gaining footholds. This study provides a snapshot in time for the state of the technologies. The technologies evaluated were based on the state of the technologies during the technology screening phase of this work in early 2019. Since that initial review, some of the technologies that were screened out have seen an increasing number of installations, and their application could provide potential savings in footprint and costs. Therefore, technologies not selected for analysis in this study should not be precluded from consideration in future alternatives analyses.
- All capital costs developed for this study are pre-Class 5 conceptual cost estimates to provide order-of-magnitude total project costs that include construction costs, contractor markups and allowances, sales tax, design and construction consulting fees, permitting, WTD staffing, contingency, and other indirect costs.
- Costs for solids system upgrades and other ancillary systems (such as for odor control at West Point and South Plant and stormwater treatment at all three plants) were not included. Evaluation of solids system upgrades was outside the scope of this study, but the potential impact on solids system capacity requirements was considered.
- Operating costs were developed for primary effluent screening (if included), secondary systems, tertiary systems (if included), and sidestream processes (if included). Operating costs for other processes and maintenance costs were not included. Operating costs consist of power, chemical, and additional labor costs.
- GHG emissions were estimated for the secondary, tertiary, and sidestream treatment processes only, and do not include emissions from other facilities/processes in each plant. A detailed GHG study should be completed as part of any future facility planning efforts.
- This study does not replace alternatives analysis or facility planning at each plant to select the upgrades for meeting future effluent nitrogen limits.

The nitrogen removal analysis for each treatment plant was completed using the steps and key assumptions described in Sections 2.2 and 2.3. Sections 3, 4, and 5 describe the results of those analyses for each plant.



# 3. West Point Treatment Plant

West Point is a high-purity oxygen (HPO) activated sludge secondary treatment plant currently rated for 215 million gallons per day (mgd) maximum month flow under its NPDES permit. West Point was designed to provide secondary treatment up to a peak hour flow of 300 mgd, and primary treatment only for flows in excess of 300 mgd (up to 440 mgd). The following subsections summarize the nitrogen removal analysis results for West Point.

## 3.1 Pre-Screened Technologies

After conducting a workshop with WTD staff to perform preliminary screening of treatment technologies, nine technologies were selected for detailed screening for West Point. Table 3-1 summarizes the selected technologies and their classification within the treatment process.

<b>Technology</b>	<b>Classification</b>
Modified Ludzack-Ettinger (MLE)	Mainstream
Four-stage modified Bardenpho (4SMB)	Mainstream
Anammox	Sidestream
Bioaugmentation	Sidestream
Membrane bioreactor (MBR)	Intensification
Partial granulation	Intensification
Biological aerated filter/fixed film	Intensification
Chemically enhanced primary treatment (CEPT)	Carbon diversion

“TM 1—Nitrogen Removal Technologies Technical Summaries and Pre-Screening” (Appendix A) describes the rationales for selecting these technologies.

## 3.2 Nitrogen Removal Scenarios and Alternatives

For West Point, four nitrogen removal scenarios and 10 alternatives were selected from the technology combination screening analysis; Table 3-2 presents the selected scenarios and alternatives.

<b>Table 3-2. West Point Nitrogen Removal Scenarios and Alternatives</b>	
<b>Scenario</b>	<b>Description</b>
<b>Scenario 1: Sidestream treatment only (no specific effluent TIN limit)</b>	
	Existing mainstream + sidestream anammox
<b>Scenario 2: Year-round N removal, lowest effluent TIN possible while maintaining current secondary treatment capacity</b>	
	MLE/MBR
	MLE/MBR + sidestream anammox
	4SMB/MBR + sidestream anammox
<b>Scenario 3: Seasonal N removal, lowest effluent TIN possible while maintaining current secondary treatment capacity</b>	
	Parallel MLE and MLE/MBR + sidestream anammox
	Parallel 4SMB and 4SMB/MBR + sidestream anammox
<b>Scenario 4: Year-round N removal, effluent TIN limit of 8 mg/L at reduced secondary treatment capacity</b>	
	MLE
	MLE + sidestream anammox
	4SMB + sidestream anammox
	4SMB + sidestream bioaugmentation

“TM 2—West Point Nitrogen Removal Technology Combinations Review and Screening” (Appendix B) provides a discussion of the technology combination screening analysis.

Scenario 1 would have the fewest capital improvements but would provide the least nitrogen removal (with an annual average effluent TIN of 22 mg/L) relative to the other scenarios. For this scenario, only sidestream treatment is added. The existing HPO secondary system would operate as is.

For scenario 2, the analysis was performed to achieve the lowest possible year-round effluent TIN concentration (3 to 7 mg/L as annual average) while maintaining the current secondary treatment capacity. All alternatives for this scenario involve full replacement of the existing HPO activated sludge process with a membrane bioreactor (MBR) process.

For scenario 3, the analysis was similarly performed to achieve the lowest possible effluent TIN concentration while maintaining the current secondary treatment capacity, but on a seasonal basis (with average effluent TIN concentration of 3 to 7 mg/L between April and October and annual average TIN concentration of 11 to 13 mg/L). For the alternatives analyzed in this scenario, the HPO secondary system would be converted to two parallel processes: the conventional activated sludge (CAS) and MBR process. Primary effluent would be split between the two processes and re-combine for disinfection.

For scenario 4, the analysis was performed to provide year-round nitrogen removal to achieve an effluent TIN concentration of 8 mg/L at a reduced secondary treatment capacity. It was assumed that maximum monthly flows over 108 to 117 mgd would be diverted away from West Point to allow the secondary system to meet the target TIN limit. The secondary system would be converted into an air activated sludge system with different configurations. This scenario would require extensive modifications to the collection system and the construction of a new WWTP to accommodate the lost capacity of West Point while also providing nitrogen removal. This analysis did not assess and include the details, including cost, of this new WWTP.

In addition to the four scenarios, a “base case” was also evaluated to assess the operational impacts of implementing nitrogen removal technologies. For West Point, base case is defined as scenario 1 without sidestream treatment. For the base case, the annual average effluent TIN concentration is 25 mg/L, while the average seasonal effluent TIN concentration during the April to October period is 31 mg/L.

### 3.3 Evaluation Results

The project team conducted a site-specific analysis of the 10 alternatives shown in Table 3-2. “TM 3A—West Point Site-Specific Nitrogen Removal Analysis of Planning Alternatives” (Appendix E) provides a more detailed discussion of the analysis.

Table 3-3 shows the range of capital costs, annual operating costs, and life cycle costs for alternatives evaluated in scenarios 1 through 3. The cost ranges for scenario 4 alternatives are not included in Table 3-3 because implementation of that scenario would, at full site buildout, result in a 50 percent reduction from the current-rated capacity of West Point. An additional treatment plant would need to be constructed elsewhere to make up for the lost capacity; therefore, scenario 4 cannot be compared with the other scenarios. Appendix E presents the results of the cost analysis for scenario 4 alternatives.

Scenarios	Capital costs <sup>a, e</sup>	Estimate range of capital costs <sup>a, b</sup>	Annual operating costs <sup>a</sup>	NPV <sup>c, e</sup>	Annual average TIN (mg/L)	Cost per pound of nitrogen removed <sup>d</sup>
1	\$89M	\$44M-\$350M	\$1.9M	\$90M	22	\$2
2	\$2,800M-\$2,900M	\$1,400M-\$11,600M	\$18M-\$21M	\$2,400M	3-7	\$13-\$15
3	\$1,700M	\$850M-\$6,800M	\$10M-\$11M	\$1,400M	11-13	\$11-\$12

M = million

NPV = net present value

a. Unescalated, undiscounted costs in 2020 dollars.

b. Range shown is for the low end (-50%) to the high end (+300%) of the total project cost estimates.

c. NPV calculated using an escalation rate of 3% and discount rate of 5.25% for 20-year life cycle period. The NPVs are presented using capital cost estimates without the -50%/+300% estimate range. The actual range of NPVs including the estimate range of capital costs would be approximately 50% lower and up to 300% higher than the values presented here. All NPVs are costs, but presented as positive values in this table.

d. Cost per pound of nitrogen removed calculated by dividing the 20-year NPV (using capital cost estimates without the -50%/+300% estimate range) by the total nitrogen removed. Total nitrogen load removed calculated from the difference between the annual raw influent total Kjeldahl nitrogen (TKN) load and plant effluent nitrogen load, both based on current-rated plant influent flows and loadings, multiplied by 20 for the 20-year life cycle period.

e. For scenarios 2 and 3, a single value (instead of a range) is shown if the capital costs and/or NPV for the alternatives for each scenario are considered the same after rounding to the same number of significant figures presented in this table.

In general, the results show that as the level of nitrogen removal increases, capital and operating costs increase. The cost-effectiveness of nitrogen removal is assessed by calculating a unit cost of nitrogen removed from the total nitrogen load removed and net present value (NPV) value, also shown in Table 3-3. The results show that scenario 1 has the lowest cost per pound of nitrogen removed, while scenario 2 has the highest cost per pound of nitrogen removed. The relatively narrow range of costs for both scenarios 2 and 3 indicate that the alternatives within each scenario have similar costs.

Figure 3-1 shows the range of GHG emissions for alternatives evaluated as part of scenarios 1 to 3 and the base case. Bar heights represent the range of GHG emissions for the different alternatives for each scenario. In general, the greater amount of nitrogen removed, the higher the GHG

emissions. It is worth noting that the GHG emissions for production of the electricity supplied to West Point are relatively low compared to most locations in the United States. The dramatic increase in electricity required for the MBR alternatives would have an even more pronounced increase in GHG emissions in most other parts of the United States.

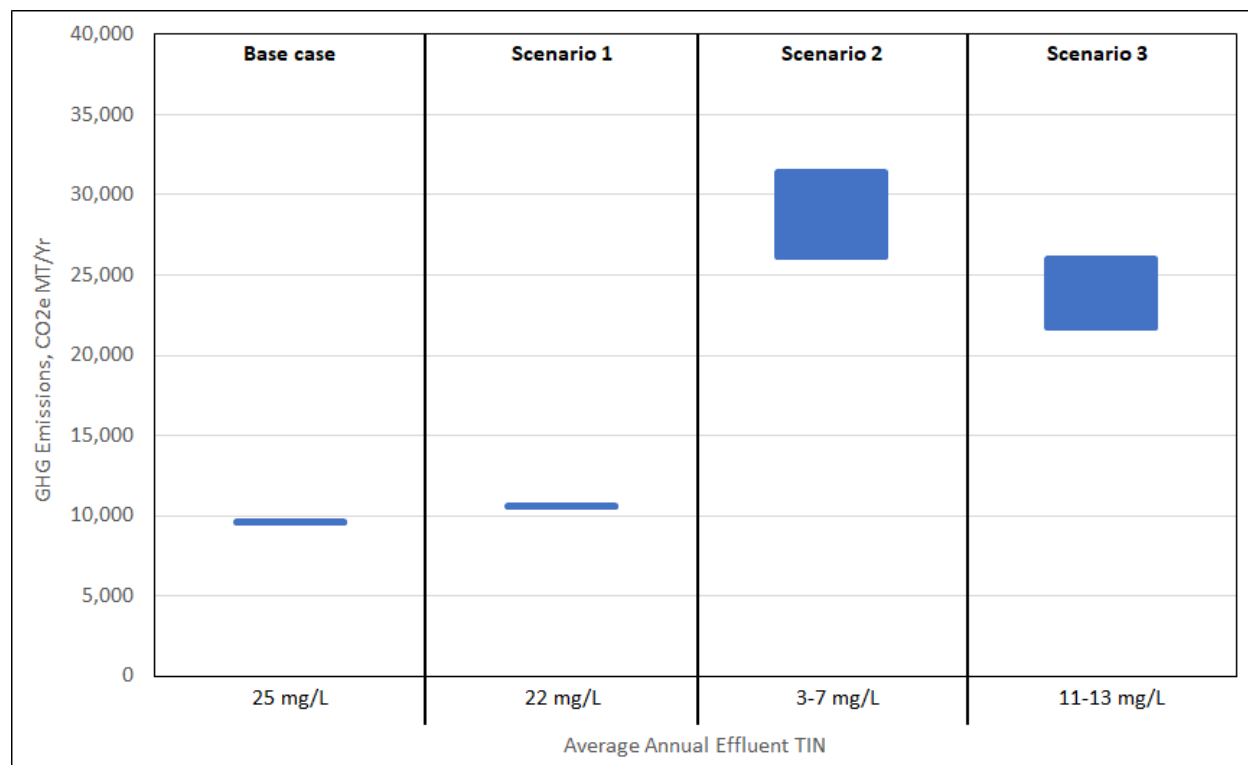

**Figure 3-1. Estimated GHG Emission Ranges for West Point Nitrogen Removal Scenarios**

(Note: Per information provided by King County, GHG emissions associated with power consumption were calculated based on an emission factor of 0.0089 metric tons per megawatt-hour (MT/MWh). This emission factor is relatively low compared to emission factors at other locations in the U.S.)

Table 3-4 compares the estimated operational requirements for the three scenarios, including electricity demand, chemical usage, and additional labor requirements in the form of full-time equivalents (FTEs), or the measurement of a full-time employment position. As a comparison to the base case, the electricity demand for scenario 1 is within approximately 5 percent of the demand for the base case. The increases in chemical demand for scenarios 2 and 3 would increase truck traffic at the treatment plant.

Scenarios	Annual electricity demand (MWh/yr)	Annual chemical demand (gal/yr) <sup>b</sup>	Additional FTEs <sup>c</sup>
1	23,000	0	0.50
2 <sup>a</sup>	102,000	7,600,000	4.50
3 <sup>a</sup>	47,000	4,900,000	5.75

- a. For scenarios 2 and 3, the average values for the alternatives of each scenario are shown.
- b. Chemical demands include those for membrane cleaning chemicals (if MBR is part of secondary treatment), caustic for alkalinity control, and methanol as supplemental carbon.
- c. Additional FTEs to operate new treatment processes and expansion of secondary treatment to provide nitrogen removal.

Figure 3-2 shows a comparison of the footprint consumed by existing facilities for secondary treatment and the expansion required for nitrogen removal for the West Point scenarios. For scenarios 2 and 3, the average footprint of the alternatives for each scenario was used. For scenario 2, where the secondary process is fully converted to MBR, all of the existing secondary clarifiers would be demolished to make space for the membrane basins and primary effluent fine-screening facility. For scenario 3, which consists of parallel CAS/MBR processes, some of the secondary clarifiers would be demolished.

The results show that scenario 3 with seasonal nitrogen removal would consume a similar total footprint as scenario 2 with year-round nitrogen removal, and that, for both scenarios, there would be no space remaining for future secondary treatment expansion. Because the footprints used for developing Figure 3-2 are based on existing rated plant capacity, expansion beyond those shown in this figure would be required to accommodate future flows and loadings.

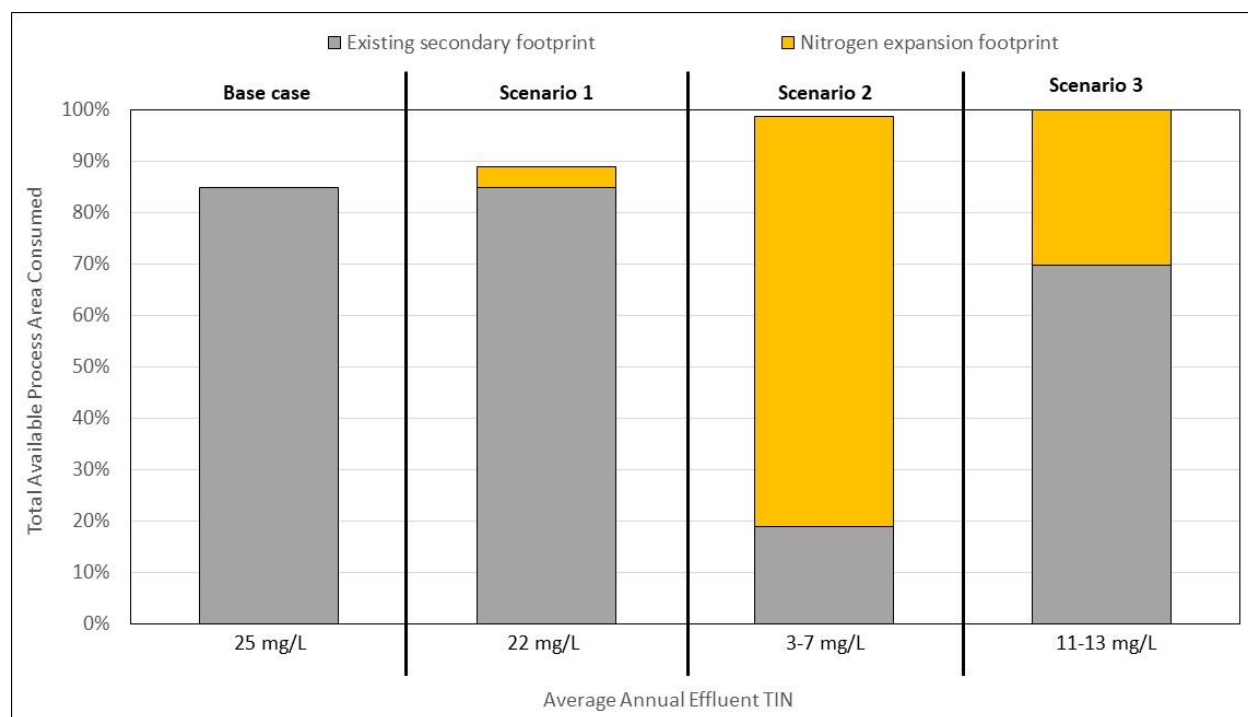

**Figure 3-2. Comparison of Footprint Consumed for West Point Nitrogen Removal Scenarios**

Footprint for primary effluent fine screening (if added), secondary, and sidestream processes only. Where new facilities would take up the vast majority of existing process areas, those areas are considered fully consumed for practical purposes. Refer to TM 3A (Appendix E) for more information.

In addition to the factors presented in Tables 3-3 and 3-4 and Figures 3-1 and 3-2, other criteria were also used to evaluate the alternatives evaluated for each scenario. These include technology status, load variation impact, flow variation impact, impacts to other processes, resource recovery, potential for removing compounds of emerging concern (CEC) and toxics, supplementary carbon source flexibility, risks, constructability, and operational complexity. Appendix E presents the results of these additional analyses.

## 3.4 Conclusions

Key conclusions from the West Point analysis of planning alternatives include the following:

- Retaining the existing mainstream treatment process and adding sidestream nitrogen removal (anammox) (scenario 1) provides the lowest cost of nitrogen removal on a per unit basis, but only reduces the average annual effluent TIN by about 3 mg/L from the base case (without sidestream treatment) and, depending on the effluent limits developed by Ecology, may not achieve required effluent TIN limits. Scenario 1 may be preferable for West Point because of its considerable site limitations and difficulties with implementing large construction projects, but would likely require WTD to have a “bubble” permit, where Ecology requires WTD to meet an overall nitrogen removal condition for all three regional treatment plants together. In a potential bubble permit approach, West Point would provide a more limited level of nitrogen removal under scenario 1, whereas South Plant and Brightwater would provide higher levels of nitrogen removal.
- Year-round nitrogen limits (scenario 2) would be difficult to achieve at the current-rated capacity and would require full conversion to an MBR process. Constructability would be exceedingly complex and difficult, likely requiring water staging, archeological survey, and extensive environmental restoration/mitigation. Maintaining secondary treatment capacity through construction is likely not possible, requiring either secondary treatment bypass or alternate treatment elsewhere. Changes to the NPDES permit may be required to allow temporary partial or full bypass of the secondary system during construction. A full conversion to an MBR process (with a peak flow of 300 mgd matching the current peak secondary treatment capacity) would also make West Point the largest MBR facility in the United States (by over three times in design capacity based on current installations) and one of the largest MBR facilities in the world.
- Seasonal nitrogen removal (scenario 3) could be achieved by implementing two parallel secondary treatment processes (CAS and MBR) with sidestream anammox, thus reducing costs and potentially alleviating some of the constructability challenges; however, the level of operational complexity would be very high to simultaneously operate two separate treatment trains with different types of treatment technology. The parallel MBR treatment train would be more than twice the size of the current MBR system at Brightwater. Changes to the NPDES permit may also be required to allow temporary partial or full bypass of the secondary system during construction.
- For both scenarios 2 and 3, the required secondary treatment facilities would consume all of the available footprint and only provide treatment for the existing capacity, limiting future capacity expansion.
- Unless converted to an MBR system, West Point can only achieve year-round average effluent TIN of 8 mg/L by reducing secondary treatment capacity to approximately 50 percent of the current-rated maximum monthly flow. Thus, a new, approximately 110-mgd maximum month capacity treatment plant would be needed to treat flows diverted from the existing West Point service area.
- In terms of operational impacts on the secondary system, on average, scenario 2 alternatives would have the highest electricity demand and chemical requirements, while scenario 3 alternatives would have the highest additional labor requirements. Higher chemical requirements would mean increased truck traffic. GHG emissions would on average increase by approximately 10 percent for scenario 1, 190 percent for scenario 2, and 150 percent for scenario 3, compared to the base case.



# 4. South Treatment Plant

South Plant is an air activated sludge secondary treatment plant currently rated for 144-mgd maximum month flow under its NPDES permit. Since 2012, the plant has trialed operation of partial nitrification/denitrification during selected summers. The following subsections summarize the nitrogen removal analysis results for South Plant.

## 4.1 Pre-Screened Technologies

After conducting a workshop with WTD staff to perform preliminary screening of treatment technologies, nine technologies were selected for detailed screening for South Plant. Table 4-1 summarizes the selected technologies and their classification within the treatment process.

Table 4-1. Technologies Selected for Detailed Screening for South Plant	
Technology	Classification
Modified Ludzack-Ettinger (MLE)	Mainstream
Four-stage modified Bardenpho (4SMB)	Mainstream
Simultaneous nitrification/denitrification (SND)	Mainstream
Anammox	Sidestream
Bioaugmentation	Sidestream
Fixed film (nitrification/denitrification or denitrification only)	Tertiary
Integrated fixed-film activated sludge	Intensification
Membrane aerated biofilm reactor	Intensification
Partial granulation	Intensification

“TM 1—Nitrogen Removal Technologies Technical Summaries and Pre-Screening” (Appendix A) describes the rationales for selecting these technologies.

## 4.2 Nitrogen Removal Scenarios and Alternatives

For South Plant, four nitrogen removal scenarios and nine alternatives were selected from the technology combination screening analysis; Table 4-2 presents the selected scenarios and alternatives.

<b>Table 4-2. South Plant Nitrogen Removal Scenarios and Alternatives</b>	
<b>Scenario</b>	<b>Description</b>
<b>Scenario 1: Sidestream treatment only (no specific effluent TIN limit)</b>	
	Existing mainstream + sidestream anammox
<b>Scenario 2: Seasonal N removal, effluent TIN limit of 8 mg/L</b>	
	MLE + tertiary denitrifying fixed-film
	MLE + sidestream anammox
<b>Scenario 3: Year-round N removal, effluent TIN limit of 8-mg/L equivalent</b>	
	4SMB + sidestream anammox
	4SMB + sidestream bioaugmentation
<b>Scenario 4: Year-round N removal, effluent TIN limit of 3 mg/L</b>	
	4SMB + sidestream anammox
	MLE + tertiary denitrifying fixed-film
	Existing mainstream + tertiary nitrifying/denitrifying fixed-film
	4SMB/MBR + sidestream anammox

“TM 2—South Plant Nitrogen Removal Technology Combinations Review and Screening” (Appendix C) provides a discussion of the technology combination screening analysis.

Scenario 1 would have the fewest capital improvements, but would provide the least nitrogen removal (with an annual average effluent TIN of 28 mg/L) relative to the other scenarios. For this scenario, only sidestream treatment is added and the plant would operate seasonally with partial nitrification/denitrification.

For scenario 2, South Plant would provide seasonal (April through October) nitrogen removal, with a monthly average effluent TIN limit of 8 mg/L during the season and an equivalent annual average effluent TIN of 23 to 26 mg/L. The alternatives for this scenario involve modifying the existing secondary treatment process to a modified Ludzack-Ettinger (MLE) configuration for seasonal operation. In addition, either a tertiary process or sidestream treatment would be added to increase nitrogen removal.

For scenario 3, South Plant would provide year-round nitrogen removal with an equivalent annual average effluent TIN limit of 8 mg/L. It is considered an equivalent limit because the effluent TIN concentrations could be lower in the summer and higher in the winter, such that on an annual average flow and loading basis the plant achieves an effluent TIN concentration no higher than 8 mg/L. The alternatives for this scenario involve modifying the existing secondary treatment process to a four-stage modified Bardenpho (4SMB) configuration for year-round operation and adding sidestream treatment.

Scenario 4 also consists of year-round nitrogen removal, but with an effluent TIN limit of 3 mg/L. The alternatives for this scenario range from modifying the existing secondary treatment process to either an MLE or 4SMB configuration, adding a tertiary denitrifying process (in addition to modifying the existing secondary process), adding a tertiary nitrifying/denitrifying process (without modifying the existing secondary process), and full conversion to an MBR process.

In addition to the four scenarios, a “base case” was also evaluated to assess the impact of implementing nitrogen removal technologies (when comparing with the results for the four

scenarios). For South Plant, base case is defined as scenario 1 without sidestream treatment. For the base case, the annual average effluent TIN concentration is 33 mg/L, while the average seasonal effluent TIN concentration during the April to October period is 21 mg/L.

### 4.3 Evaluation Results

The project team conducted a site-specific analysis of the nine alternatives. “TM 3B—South Plant Site-Specific Nitrogen Removal Analysis of Planning Alternatives” (Appendix F) provides a more detailed discussion of this analysis.

Table 4-3 summarizes the range of estimated capital and operating costs, life cycle costs, and unit costs of nitrogen removed for alternatives analyzed for each of the four scenarios. In general, the results show that as the level of nitrogen removal increases (thus progressing from scenario 1 through 4), the capital and operating costs increase. Besides scenario 1, which has the lowest cost per pound of nitrogen removed, scenario 3 has the next lowest cost per pound of nitrogen removed.

**Table 4-3. Cost Estimate Ranges for South Plant Nitrogen Removal Scenarios**

Scenarios	Capital costs <sup>a</sup>	Estimate range of capital costs <sup>a, b</sup>	Annual operating costs <sup>a</sup>	NPV <sup>c</sup>	Annual average TIN (mg/L)	Cost per pound of nitrogen removed <sup>d</sup>
1	\$88M	\$44M-\$350M	\$1.7M	\$87M	28	\$1
2	\$460M-\$630M	\$230M-\$2,500M	\$3.5M-\$5.4M	\$400M-\$540M	23-26	\$3-\$5
3	\$610M-\$710M	\$310M-\$2,800M	\$6.0M-\$8.2M	\$570M-\$610M	8	\$3 <sup>e</sup>
4	\$1,000M-\$2,000M	\$510M-\$8,200M	\$5.9M-\$17.3M	\$850M-\$1,700M	3	\$4-\$7

M = million

NPV = net present value

a. Unescalated, undiscounted costs in 2020 dollars.

b. Range shown is for the low end (-50%) to the high end (+300%) of the total project cost estimates.

c. NPV calculated using an escalation rate of 3% and discount rate of 5.25% for 20-year life cycle period. Estimated capital costs (without the -50%/+300% range) were used. The NPVs are presented using capital cost estimates without the -50%/+300% estimate range. The actual range of NPVs, including the estimate range of capital costs, would be approximately 50% lower and up to 300% higher than the values presented here. All NPVs are costs, but presented as positive values in this table.

d. Cost per lb N removed calculated by dividing the 20-year NPV (using capital cost estimates without the 50%/+300% estimate range) by the total N removed. Total N load removed calculated from the difference between the annual raw influent TKN load and plant effluent nitrogen load, both based on current-rated plant influent flows and loadings, multiplied by 20 for the 20-year life cycle period.

e. A single value (instead of a range) is shown because the costs per pound of nitrogen removed for the alternatives are considered the same after rounding to the same number of significant figures presented in this table.

Figure 4-1 shows the GHG emission ranges for scenarios 1 through 4 and the base case. In general, the greater the amount of nitrogen removed, the higher the GHG emissions. It should be noted that King County is currently contracted to purchase all-renewable electricity from Puget Sound Energy for South Plant, resulting in no GHG emissions due to energy. However, there is a risk that if electricity use increases significantly from current usage for a given alternative, the County may not be able to purchase all-renewable electricity or may need to pay an additional premium for the additional all-renewable electricity. This could increase either the GHG emissions or the operating costs for scenarios 3 and 4 because of significant energy use increases associated with those scenarios compared to current usage.

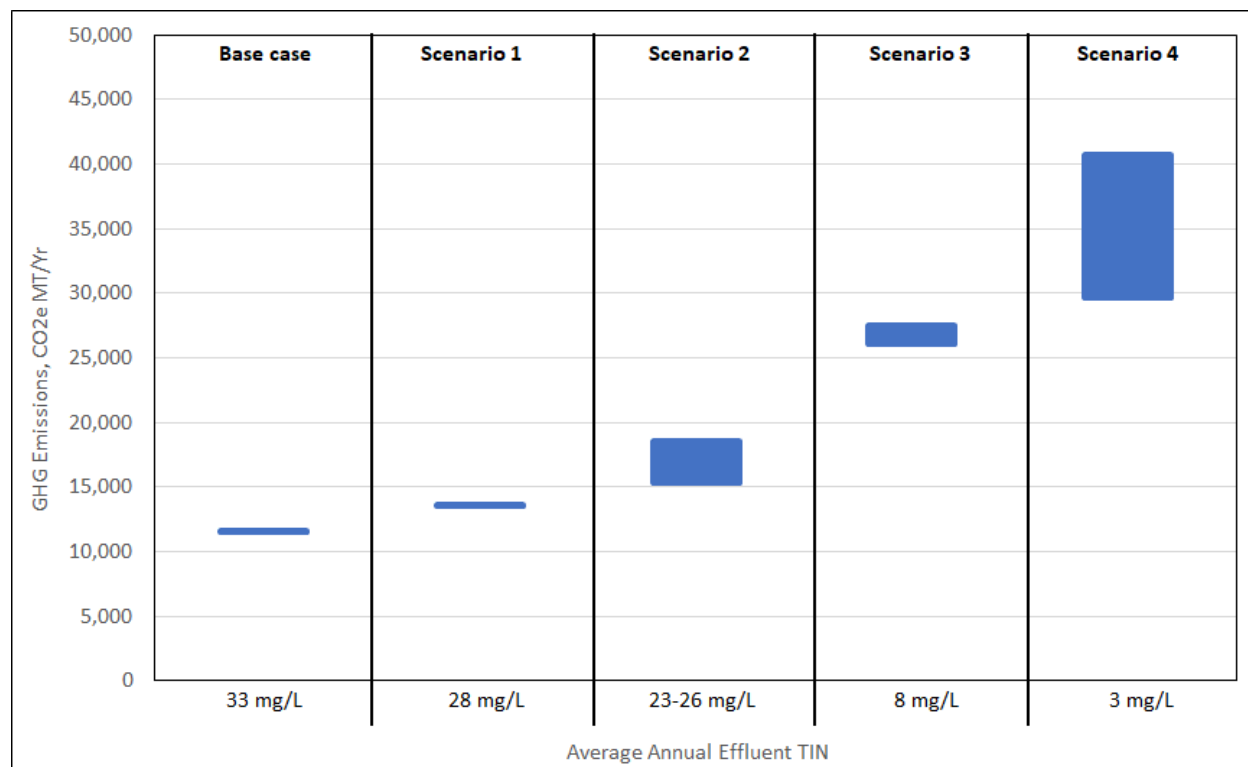

**Figure 4-1. Estimated GHG Emission Ranges for South Plant Nitrogen Removal Scenarios**

(Note: Per information provided by King County, GHG emissions associated with power consumption are assumed to be zero for this analysis because South Plant is now purchasing 100% renewable energy from Puget Sound Energy.)

Table 4-4 compares the estimated operational requirements for the four scenarios. As a comparison to the base case, the electricity demand for scenario 1 is within approximately 5 percent of the demand for the base case. The large increase in electricity demand for scenario 4 compared to other scenarios is skewed by the high demand for an alternative involving conversion to MBR, while the large increase in chemical demand for scenario 4 is skewed by the high caustic and methanol requirements for alternatives including tertiary treatment.

Scenarios	Annual electricity demand (MWh/yr)	Annual chemical demand (gal/yr) <sup>b</sup>	Additional FTEs <sup>c</sup>
1	19,000	200,000	0.50
2 <sup>a</sup>	23,000	2,000,000	1.75
3 <sup>a</sup>	33,000	3,000,000	2.00
4 <sup>a</sup>	54,000	5,600,000	3.13

a. For scenarios 2, 3, and 4, the average values for the alternatives of each scenario are shown.

b. Chemical demands include those for membrane cleaning chemicals (if MBR is part of secondary treatment), caustic for alkalinity control, and methanol as supplemental carbon.

c. Additional FTEs to operate new treatment processes and expansion of secondary treatment to provide nitrogen removal.

Figure 4-2 shows a comparison of the existing footprint and footprint consumed by facilities required for nitrogen removal for the South Plant scenarios. The average footprint of the alternatives for each of scenarios 2 and 3 was used for this figure. For scenario 4, the minimum footprint shown is for the alternative with no intensification and tertiary treatment, and the maximum footprint shown is for the alternative with intensification (full conversion to MBR). In the latter case, the existing secondary clarifiers would be demolished and replaced with membrane basins, leaving footprint available for future expansion. The results show that without intensification, the remaining available footprint for future plant expansion would be somewhat limited to meet a year-round effluent TN limit of 8 mg/L and very limited to meet a limit of 3 mg/L.

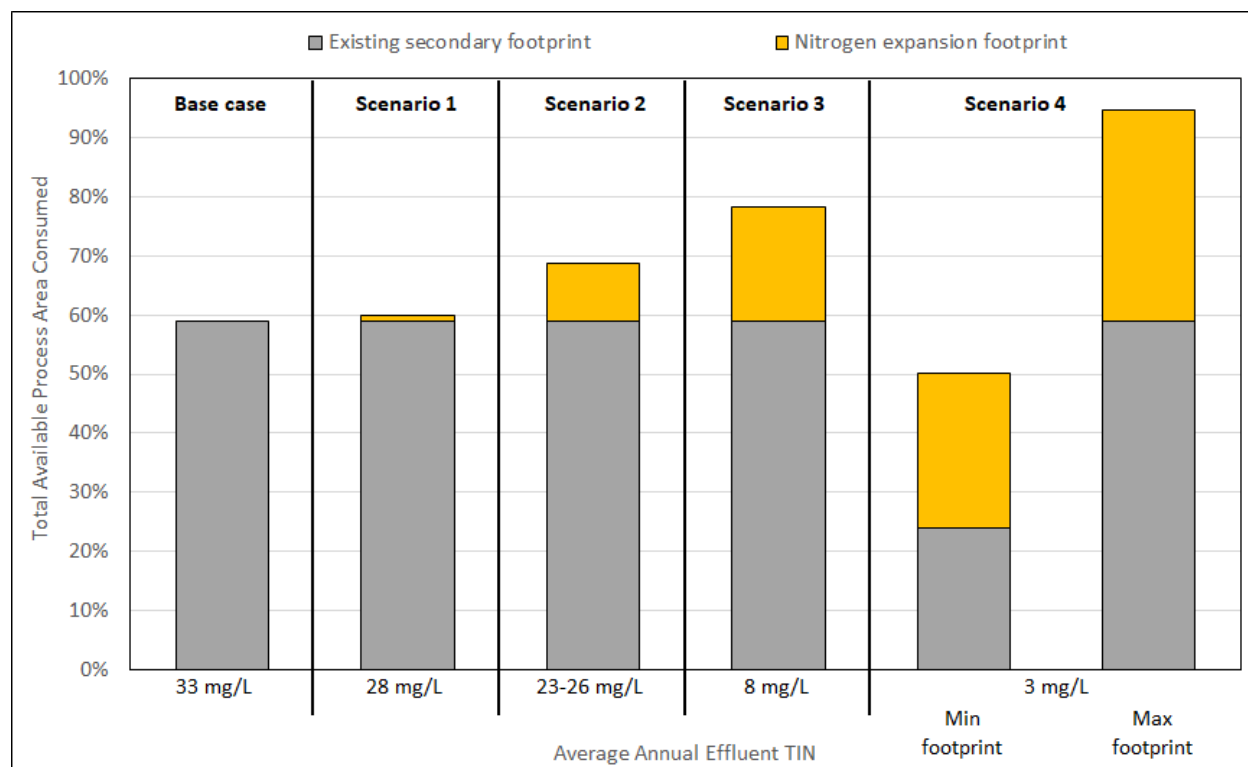

**Figure 4-2. Comparison of Footprint Consumed for South Plant Nitrogen Removal Scenarios**

*Footprint for primary effluent fine screening (if added), secondary, tertiary, and sidestream processes only.*

In addition to the factors presented in Tables 4-3 and 4-4 and Figures 4-1 and 4-2, other criteria were also used to evaluate the alternatives. These include technology status, load variation impact, flow variation impact, impacts to other processes, resource recovery, potential for removing CECs and toxics, supplementary carbon source flexibility, risks, constructability, and operational complexity. Appendix F presents the results of these analyses.

## 4.4 Conclusions

Key conclusions from the South Plant analysis of planning alternatives include the following:

- Retaining the existing mainstream treatment process and adding sidestream treatment (scenario 1) provides the lowest overall cost of nitrogen removal on a per unit basis; however, adding sidestream treatment alone only reduces the annual average effluent TIN by about 5 mg/L (to 28 mg/L) from the base case and may not achieve required effluent nitrogen permit limits set by Ecology.

- Seasonal nitrogen removal with an effluent TIN limit of 8 mg/L (scenario 2) can be achieved with mainstream process upgrades or a combination of mainstream process upgrades and adding tertiary nitrogen removal, with the addition of sidestream nitrogen removal applicable to either approach. Both approaches provide some room for future expansion.
- Year-round nitrogen removal with an effluent TIN limit of 8 mg/L equivalent (scenario 3) can be achieved using a similar approach to that required for seasonal nitrogen removal. The results indicate that the upgraded and new facilities would fit within the existing plant footprint, but there would be limited available space for future expansion. Estimated costs (for both capital and operating) and GHG emissions would increase from the values for scenario 2, but the incremental increases in capital costs are relatively small. Other than scenario 1, this scenario has the lowest cost per pound of nitrogen removed.
- Year-round nitrogen removal with an effluent TIN limit of 3 mg/L (scenario 4) fits on the existing facility site without intensification, but nearly all available footprint would be required, leaving no room available for future expansion. Intensification, such as the MBR evaluated in this study, would be required to provide space for future expansion. However, intensification typically requires additional energy or chemical use, which increases operational costs and GHG emissions. Similar to West Point, full conversion to an MBR process would make South Plant the largest MBR facility in the United States (by over three times in design capacity based on current installations) and one of the largest MBR facilities in the world.
- In terms of operational impacts on the secondary system, on average, scenario 4 alternatives have the highest electricity demand, chemical usage, and additional labor requirements, followed by scenario 3 alternatives, and then scenario 2 alternatives (with scenario 1 having the lowest requirements). Scenarios 2 to 4 would all substantially increase chemical requirements and thus truck traffic, compared to scenario 1. The increase in electricity demand for the scenario 4 alternative involving conversion to MBR and the increase in chemical requirements for the scenario 4 alternatives involving tertiary treatment would both be significant. GHG emissions would on average increase by approximately 20 percent for scenario 1, 50 percent for scenario 2, 130 percent for scenario 3, and 220 percent for scenario 4 compared to base case.

# 5. Brightwater Treatment Plant

Brightwater is an air activated sludge secondary treatment plant using MBR technology currently rated for 40.9-mgd maximum month flow under its NPDES permit. The MBR process is combined with chemically enhanced primary treatment (CEPT) during peak wet weather flow events, when any flows in excess of the MBR capacity receive CEPT and bypass secondary treatment. As an MBR facility, Brightwater currently provides nitrification and partial denitrification year-round. The following subsections summarize the nitrogen removal analysis results for Brightwater.

## 5.1 Pre-Screened Technologies

After conducting a workshop with WTD staff to perform preliminary screening of treatment technologies, eight technologies were selected for detailed screening. Table 5-1 summarizes the selected technologies and their classification within the treatment process. Because Brightwater has MBR for intensification already, this technology was assumed for all Brightwater alternatives.

<b>Technology</b>	<b>Classification</b>
Modified Ludzack-Ettinger (MLE)	Mainstream
Four-stage modified Bardenpho (4SMB)	Mainstream
Simultaneous nitrification/denitrification (SND)	Mainstream
Anammox	Sidestream
Fixed film (denitrification only)	Tertiary
Membrane bioreactor (MBR)	Intensification
Partial granulation	Intensification
Chemically enhanced primary treatment	Carbon diversion

“TM 1—Nitrogen Removal Technologies Technical Summaries and Pre-Screening” (Appendix A) presents the rationales for selecting these technologies.

## 5.2 Nitrogen Removal Scenarios and Alternatives

For Brightwater, three nitrogen removal scenarios and seven alternatives were selected from the technology combination screening analysis; Table 5-2 presents the selected scenarios and alternatives.

<b>Table 5-2. Brightwater Nitrogen Removal Scenarios and Alternatives</b>	
<b>Scenarios</b>	<b>Description</b>
<b>Scenario 1: SND with sidestream treatment (no specific effluent TIN limit)</b>	
	SND/MBR + sidestream anammox
<b>Scenario 2: Year-round N removal, effluent TIN limit of 8-mg/L equivalent</b>	
	SND/MBR + sidestream anammox
	MLE/MBR + sidestream anammox
	MLE/MBR + tertiary denitrifying fixed-film + sidestream anammox
<b>Scenario 3: Year-round N removal, effluent TIN limit of 3 mg/L</b>	
	SND/MBR + sidestream anammox
	4SMB/MBR + sidestream anammox
	MLE/MBR + tertiary denitrifying fixed-film + sidestream anammox

“TM 2—Brightwater Nitrogen Removal Technology Combinations Review and Screening” (Appendix D) provides a discussion of the technology combination screening analysis.

Scenario 1 would have the fewest capital improvements, but would provide the least nitrogen removal (with an annual average effluent TIN of 12 mg/L) relative to the other scenarios. For this scenario, only sidestream treatment is added in comparison to a base case. For the base case, it was assumed that the existing MBR secondary system has already been upgraded for simultaneous nitrification/denitrification (SND) as well as improved aeration control resulting from the ongoing Brightwater Aeration Basin Optimization (BWABO) project. The BWABO project (WTD capital project number 1129532) includes a number of modifications to the MBR secondary system to improve performance and reduce chemical and energy demands. The annual average effluent TIN concentration for the base case is 17 mg/L.

In addition, the base case also assumes membrane cassettes would be installed in membrane basins 9 and 10, and that one new aeration basin and two new membrane basins would be constructed. These new facilities would be needed to meet the net environmental benefit requirements at the current-rated flows and loadings. Although capital costs for these new facilities are included in this study, the costs for modifying the existing basins to operate in SND mode are not included because those costs would be already allocated as part of the BWABO project.

For scenario 2, Brightwater would provide year-round nitrogen removal with an equivalent annual average effluent TIN limit of 8 mg/L. The alternatives for this scenario involve either keeping the existing MLE configuration (with improvements) or converting to SND operation, with the addition of sidestream treatment. Tertiary treatment is added in one of the alternatives to increase nitrogen removal.

Scenario 3 also consists of year-round nitrogen removal, but with an effluent TIN limit of 3 mg/L. The alternatives for this scenario range from SND operation, modifying the secondary treatment process to 4SMB configuration, and adding a tertiary process. All of the alternatives include adding sidestream treatment.

A seasonal nitrogen removal scenario was not included because, as an existing MBR facility, Brightwater is currently already providing year-round full nitrification but only a limited degree of denitrification. Increasing the degree of denitrification year-round would have operational benefits (such as reduced chemical and electricity costs).



## 5.3 Evaluation Results

The project team conducted a site-specific analysis of the seven alternatives. “TM 3C—Brightwater Site-Specific Nitrogen Removal Analysis of Planning Alternatives” (Appendix G) provides a more detailed discussion of the analysis.

Table 5-3 summarizes the range of capital costs, operating costs, life cycle costs and unit cost of nitrogen removed for the alternatives evaluated for each of the three scenarios. In general, the results show that as the level of nitrogen removal increases, life cycle costs increase. Scenario 1 has the lowest cost per pound of nitrogen removed. For scenarios 2 and 3, alternatives with a tertiary system were found to have higher cost per pound of nitrogen removed than alternatives with only modifications to the existing MBR system and the addition of sidestream treatment.

**Table 5-3. Cost Estimate Ranges for Brightwater Nitrogen Removal Scenarios**

Scenarios	Capital costs <sup>a</sup>	Estimate range of capital costs <sup>b</sup>	Annual Operating costs <sup>a</sup>	NPV <sup>c</sup>	Annual Average TIN (mg/L)	Cost per pound of nitrogen removed <sup>d</sup>
Scenario 1	\$130M	\$63M-\$500M	\$2.9M	\$130M	12	\$3
Scenario 2	\$320M-\$460M	\$160M-\$1,800M	\$4.0M-\$5.1M	\$290M-\$410M	8	\$5-\$8
Scenario 3	\$410M-\$480M	\$200M-\$1,900M	\$3.9-\$5.6M	\$360M-\$430M	3	\$6-\$7

M = million

NPV = net present value

a. Unescalated, undiscounted costs in 2020 dollars.

b. Range shown is for the low end (-50%) to the high end (+300%) of the total project cost estimates.

c. NPV calculated using an escalation rate of 3% and discount rate of 5.25% for 20-year life cycle period. Estimated capital costs (without the -50%/+300% range) were used. The NPVs are presented using capital cost estimates without the -50%/+300% estimate range. The actual range of NPVs including the estimate range of capital costs would be approximately 50% lower and up to 300% higher than the values presented here. All NPVs are costs but presented as positive values in this table.

d. Cost per lb N removed calculated by dividing the 20-year NPV (using capital cost estimates without the 50%/+300% estimate range) by the total N removed. Total N load removed calculated from the difference between the annual raw influent TKN load and plant effluent nitrogen load, both based on current-rated plant influent flows and loadings, multiplied by 20 for the 20-year life cycle period.

Figure 5-1 presents the GHG emission ranges for scenarios 1 to 3 and the base case. In general, the greater amount of nitrogen removed, the higher the GHG emissions; however, the increasing trend is more dependent on the technologies used for the alternatives. Figure 5-1 shows two different bars for Scenarios 2 and 3: one for SND alternatives and the other for other alternatives (without SND). Estimated GHG emissions are consistently higher for SND alternatives because of the high nitrous oxide emissions estimated for SND operation. These nitrous oxide emission estimates are based on only the few research studies that have been conducted for the emissions from SND, and are likely conservative.

Additionally, although the odor control system at Brightwater may remove a portion of the nitrous oxides released from the aeration basins, they are assumed to remain unchanged in this study. Nitrous oxide information should be gathered from the full-scale SND operation at Brightwater to provide a more informed decision on GHG emissions from these processes. It is important to note that the GHG emissions for production of the electricity supplied to Brightwater are relatively low compared to most locations in the United States. While SND operation generally provides savings in electricity compared to non-SND operation, the corresponding reduction in GHG emissions is significantly over-shadowed by the increase in GHG emissions due to nitrous oxides emissions. SND may be more advantageous for lowering GHG emissions at other locations where the GHG emission factor for electricity production is higher.

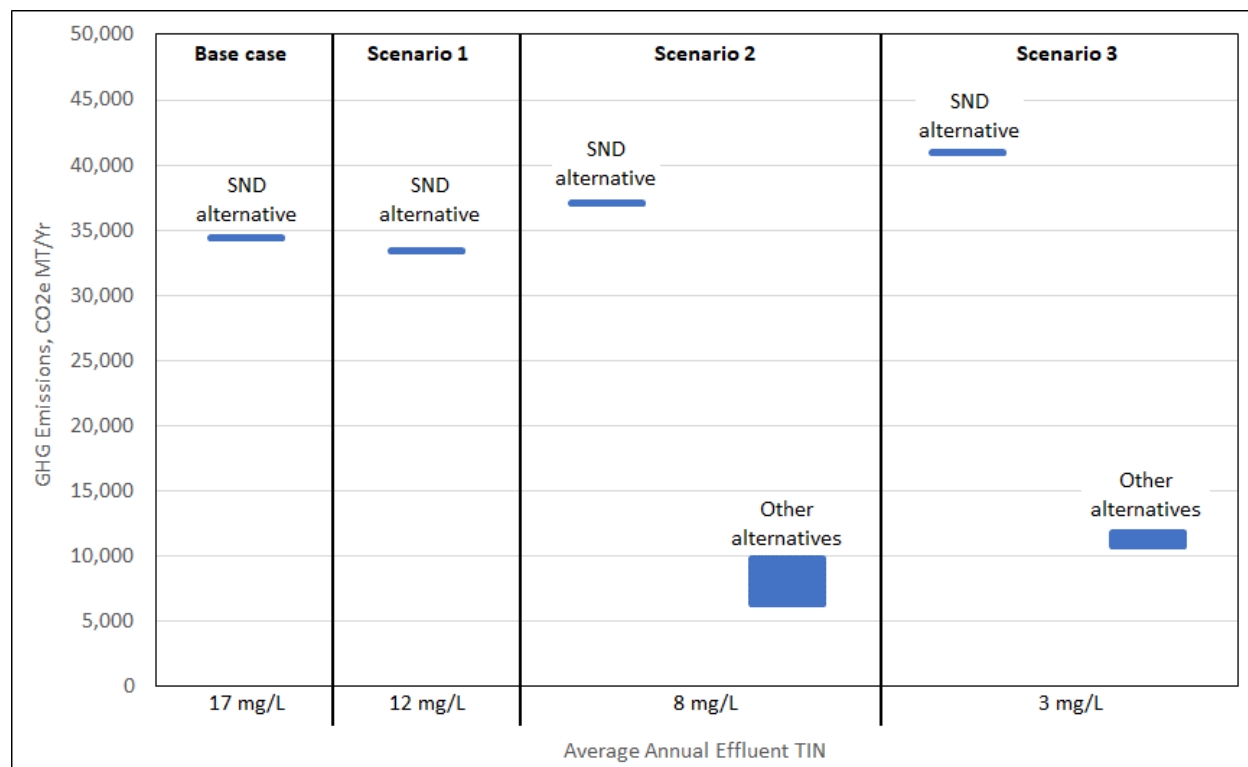

**Figure 5-1. Estimated GHG Emission Ranges for Brightwater Nitrogen Removal Scenarios**

(Note: Per information provided by King County, GHG emissions associated with power consumption were calculated based on an emission factor of 0.0065 MT/MWh. This emission factor is relatively low compared to emission factors at other locations in the U.S.)

Table 5-4 compares the estimated operational requirements for the three scenarios. For both scenarios 2 and 3, the operational requirements are higher for alternatives that include addition of tertiary treatment than for alternatives without addition of tertiary treatment. As a comparison to the base case, the electricity demand for scenario 1 is within approximately 5 percent of the demand for the base case.

Scenarios	Annual electricity demand (MWh/yr)	Annual chemical demand (gal/yr) <sup>b</sup>	Additional FTEs <sup>c</sup>
1	19,000	1,500,000	0.75
2 <sup>a</sup>	24,000	1,800,000	2.08
3 <sup>a</sup>	24,000	1,600,000	2.33

- a. For scenarios 2 and 3, the average values for the alternatives of each scenario are shown.
- b. Chemical demands include those for membrane cleaning chemicals, caustic for alkalinity control, and methanol as supplemental carbon.
- c. Additional FTEs to operate new treatment processes and expansion of secondary treatment to increase nitrogen removal

Figure 5-2 shows a comparison of the footprint consumed by facilities required for nitrogen removal for the Brightwater scenarios. The average footprint of the alternatives for each of scenarios 2 and 3 was used for this figure. In general, the results show that the remaining available footprint for future plant expansion would decrease as the level of nitrogen increases. For scenario 3, without adding a tertiary process, future expansion that includes additional aeration basins would require significant

excavation of the east hillside (beyond what is shown on the site layouts for the new aeration basins in Appendix G).

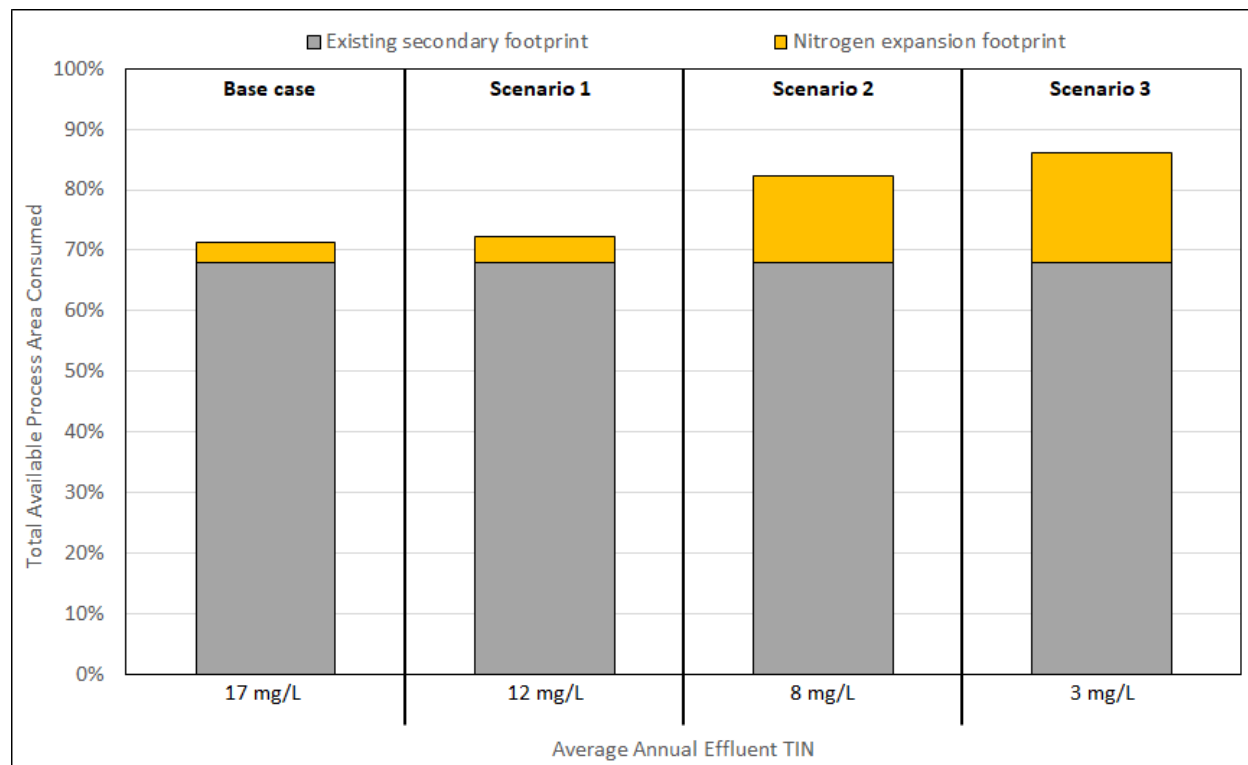

**Figure 5-2. Comparison of Footprint Consumed for Brightwater Nitrogen Removal Scenarios**

Footprint for primary, secondary, tertiary (if added), sidestream, and primary/secondary odor control processes only. Area consumed for scenarios 2 and 3 is based on the average footprint of alternatives for each scenario. It may be possible to increase available process area through additional expansion into the existing east hillside area (beyond what is shown on the site layouts for new aeration basins and tertiary denitrification facilities in Appendix G).

In addition to the information presented in Tables 5-3 and 5-4 and Figures 5-1 and 5-2, other criteria were also used to evaluate the alternatives. These criteria include technology status, load variation impact, flow variation impact, impacts to other processes, potential for removing CECs and toxics, supplementary carbon source flexibility, risks, constructability, and operational complexity. TM 3C (Appendix G) presents the results of these analyses.

## 5.4 Conclusions

Key conclusions from the Brightwater analysis of planning alternatives include the following:

- The base case assumes that SND (in addition to various aeration system improvements) is implemented as part of the BWABO project and would greatly improve the nitrogen removal performance from the existing operating condition.
- Implementing SND in combination with sidestream anammox (scenario 1) would further reduce effluent TIN by about 5 mg/L (to 12 mg/L as an annual average concentration), but additional improvements may be needed to meet low permit limits that may be required by Ecology.
- Year-round effluent TIN of 8 mg/L equivalent (scenario 2) could be achieved on the existing plant site using any of the options evaluated for scenario 2, each with varying levels of operational and maintenance complexity and cost.

- Year-round effluent TIN limit of 3 mg/L (scenario 3) is achievable for all alternatives studied. All of the alternatives for this scenario require excavating a portion of the east hillside. Without a tertiary process, there would be very limited space for future expansion that requires additional aeration basins without further excavation of the east hillside. While the incremental cost increases are relatively small to go from an 8 to 3 mg/L TIN limit, the available footprint for future plant expansion would be a primary concern.
- In terms of operational impacts on the secondary system, on average, scenario 2 and 3 alternatives would increase the electricity demand by approximately the same compared to scenario 1. Scenario 2 alternatives have the highest chemical requirements, while scenario 3 alternatives have the highest additional labor requirements. The impact on GHG emissions relative to the base case is dependent on whether SND is included as part of the alternative. With SND, GHG emissions would remain about the same for scenario 1 and would increase by approximately 10 and 20 percent for scenarios 2 and 3, respectively, compared to the base case. Without SND, the GHG emissions would be reduced significantly, by about 80 and 70 percent for scenarios 2 and 3, respectively, compared to the base case. The large differences in GHG emissions are due to the high estimated nitrous oxide emissions from SND operation based on available literature.
- A potential risk is the increased difficulty to meet a TIN limit in a combined effluent (from MBR and CEPT) during winter peak flow conditions (without transferring flows to other plants) because the CEPT effluent would have higher TIN concentrations than the MBR effluent. Currently, the ability to bypass flow that receives CEPT only is limited by the need to meet net environmental benefit (NEB) requirements in the current NPDES permit. With a TIN limit, CEPT bypass would be limited more by the need to achieve the necessary overall nitrogen removal instead of the NEB requirements. The additional infrastructures (including primary effluent screens and membrane basins) required to treat the higher flows in the MBR system during peak flow events are accounted for in this analysis, but the impact of peak flows on capital upgrades would need to be further evaluated in future studies.

## 6. Overall Conclusions

Evaluating the results of West Point, South Plant, and Brightwater together, the overall conclusions of the Nitrogen Removal Study are as follows:

- In general, as the level of nitrogen removal increases, capital and operating costs, GHG emissions, and footprint requirements increase. For West Point and South Plant, converting the secondary process to MBR would significantly increase the electrical requirements (by more than three times when compared to the scenario of adding sidestream treatment only). Any alternative that involves conversion to MBR, parallel treatment processes, or the addition of tertiary treatment would increase operational complexity and increase operations staff requirements.
- There are some exceptions to the general trend of increasing operating costs, GHG emissions, and footprints with the increasing level of nitrogen removal. These are as follows:
  - Certain configurations provide chemical savings (e.g., 4SMB), such that the overall operating costs could become lower than for alternatives with other configurations (e.g., MLE or SND), even if a higher level of nitrogen removal is achieved.
  - GHG emissions are dependent on the technologies used for the alternatives and the assumed emission factors. For Brightwater, estimated GHG emissions are higher for certain alternatives (i.e., SND) because of the high nitrous oxide emissions estimated for operation.
  - Footprint requirements are reduced significantly if an intensification process (such as MBR) or, to a lesser extent, a tertiary process is used to achieve lower effluent TIN limits.
- As mentioned in Section 2.3, the analyses for this study were performed assuming the current-rated flows and loadings for each plant. The analyses do not include sizing and costing of facilities needed for future plant expansion to accommodate growth and asset management. Alternative regional treatment strategies (such as allowing certain plant or plants to accommodate more growth or building a fourth regional facility) are not considered in this study.
- Adding sidestream treatment as the sole new process would provide the lowest overall cost of nitrogen removal on a per unit basis. However, adding sidestream treatment alone only reduces the annual average effluent TIN concentrations by about 3 to 5 mg/L from the base case levels and would not likely achieve the potential effluent TIN limits Ecology is considering, either on a seasonal or year-round basis. Sidestream treatment could be a precursor to mainstream or tertiary nitrogen removal upgrades.
- While this study focused on nitrogen removal scenarios at each treatment facility, the results can be used to evaluate “bubble” permit options by combining the results of different scenarios for the three facilities. If WTD is regulated through a bubble permit approach for its regional facilities, adding sidestream treatment only would be an advantageous option for West Point because of the significant site limitations at that facility, as noted below.
- Adding a tertiary system results in a notable increase (approximately 20 to 50 percent) in the unit cost of nitrogen removed when compared to modifying and expanding the secondary system to achieve the same level of nitrogen removal. However, use of tertiary treatment provides the benefit of reducing the size of aeration basin expansion and, thus, provides more space for future expansion.

- Results of this study conducted based on the current-rated capacity of each plant indicate that, to achieve a year-round effluent TIN limit of 3 mg/L, all three treatment plants would have space limitations for future plant expansion to increase plant capacities.
  - For West Point, there would be no space remaining for future expansion if any upgrade beyond adding sidestream treatment is required to achieve nitrogen removal. Any construction beyond adding sidestream treatment to provide year-round, or likely even seasonal nitrogen removal, would be exceedingly complex and difficult and would require bypassing secondary treatment or alternate treatment elsewhere.
  - For South Plant, limited space would remain for future expansion if a year-round effluent TIN limit of 8 mg/L or less were met without converting to an intensification process, such as MBR.
  - For Brightwater, achieving a year-round TIN limit of 3 mg/L would allow little remaining space for future plant expansion even after excavating a portion of the east hillside for aeration basin expansion or adding tertiary treatment; further excavation of the east hillside would be required for future plant expansion.
- Figure 6-1 summarizes the range of capital costs for the different nitrogen removal scenarios for each plant. In general, the capital cost increases as the effluent TIN limit decreases. The costs for West Point are shown to be the highest, followed by South Plant, then Brightwater. For West Point, there is a notable increase in capital cost by going from seasonal to year-round nitrogen removal, as the latter requires full conversion to MBR while the former would allow parallel CAS/MBR treatment (which preserves more of the existing infrastructure). The incremental increases in capital costs to go from seasonal to year-round nitrogen removal at South Plant (at a TIN limit of 8 mg/L) and to go from a year-round limit of 8 to 3 mg/L at Brightwater are relatively small, but operational impacts and GHG emissions would increase to meet the more stringent limit at each plant. For South Plant, there is a large range in capital costs for scenario 4 to achieve a year-round effluent TIN limit of 3 mg/L, with the lower end based on modifying the existing process and the higher end based on full conversion to MBR.
- A full conversion to an MBR process at West Point (with a peak flow of 300 mgd, matching the current peak secondary treatment capacity) or at South Plant would make each plant the largest MBR facility in the United States (by more than three times in design capacity based on current installations) and one of the largest MBR facilities in the world.
- Future alternatives analyses and facility planning are needed to select the nitrogen removal alternative for each facility, especially as more clarity is provided by Ecology on potential future nitrogen limits. While this study provides the range of planning-level information to meet different limits, future studies can supplement the results of this study by considering advancements in nitrogen removal technologies as well as assessing impacts of operation at both actual and projected flows and loads.
- Evaluation of reclaimed water usage was beyond the scope of this study. Future facility plans and alternatives analyses should also consider reclaimed water as a potential way to reduce nitrogen discharges to Puget Sound.

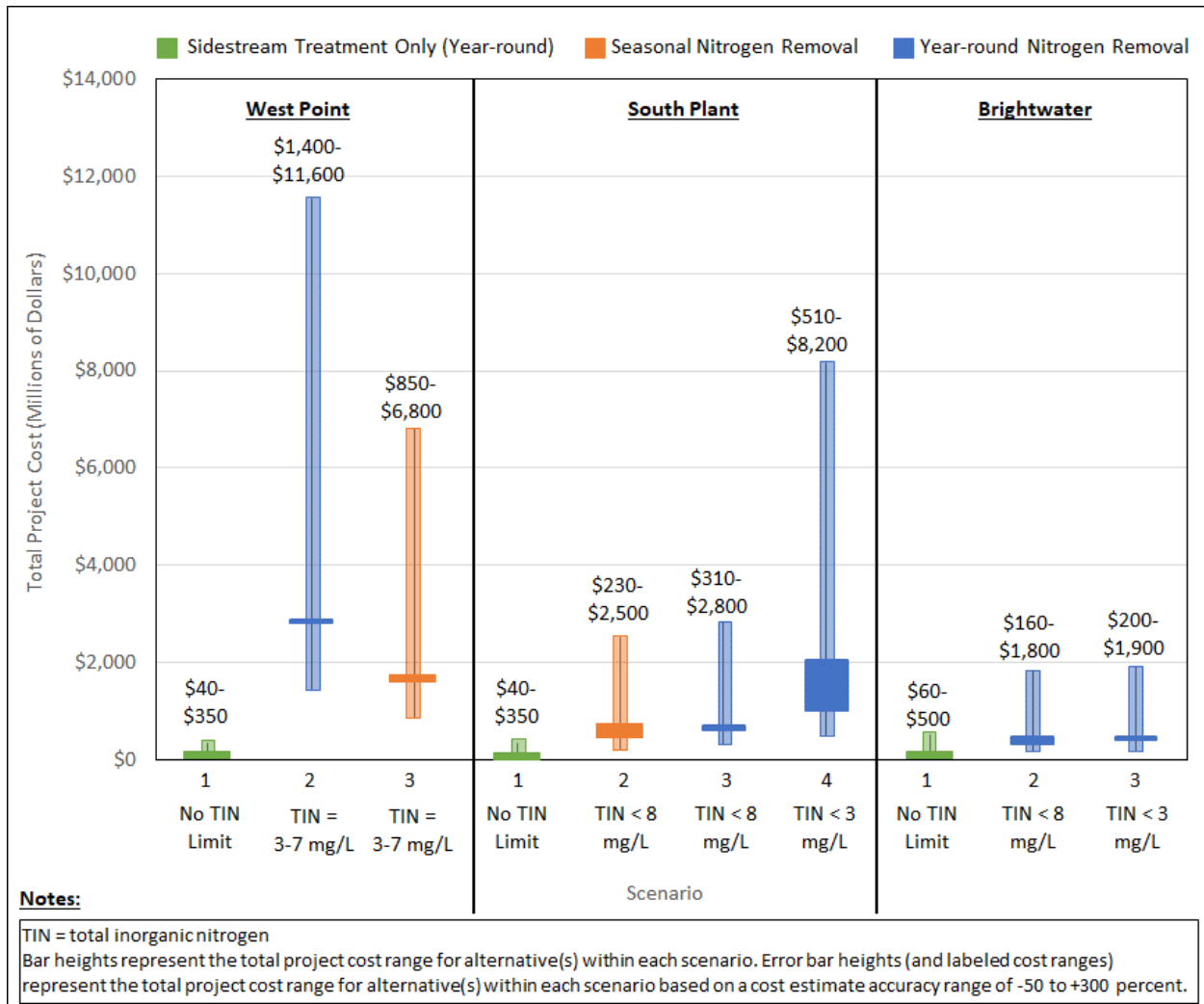

**Figure 6-1. Total Project Cost Ranges for Different Nitrogen Removal Scenarios**

Bar heights (for wider bars) represent range of costs for the alternatives for each scenario. Error bars represent minimum and maximum total project costs based on cost estimate accuracy range of -50/+300%.





# 7. References

- Carollo. Assessment of Potential Nitrogen Removal Technologies at the South Treatment Plant and their Impact on Future Water Reuse Program Development (South Plant Nitrogen Removal Study). June 2010.
- Carollo. Assessment of Potential Nitrogen Removal Technologies at the West Point Plant and their Impact on Future Water Reuse Program Development (West Point Nitrogen Removal Study). March 2011.
- Tetra Tech and Washington State Department of Ecology. Technical and Economic Evaluation of Biological Nitrogen and Phosphorus Removal at Municipal Wastewater Treatment Facilities. Pub. No. 11-10-060, June 2011.
- Washington State Department of Ecology. Puget Sound Nutrient Source Reduction Project—Volume 1: Modeling Updates and Bounding Scenarios. Pub. No. 19-03-001, January 2019.



## Appendix A: TM 1

---

This page intentionally left blank.



# Technical Memorandum

701 Pike Street, Suite 1200  
Seattle, WA 98101-2310

Phone: 206-624-0100  
Fax: 206-749-2200

Prepared for: King County

Project Title: King County Flows and Loads – Nitrogen Removal Study

Project No.: 151084.460

## Technical Memorandum 1

Subject: Nitrogen Removal Technologies Technical Summaries and Pre-Screening

Date: June 5, 2019

To: Eron Jacobson, KC Nitrogen Removal Task Lead

From: Rick Kelly, BC Nitrogen Removal Task Lead

Copy to:

Prepared by:   
Richard Kelly, Ph.D., P.E., WA License. No. 45235, Expiration 6/3/2021

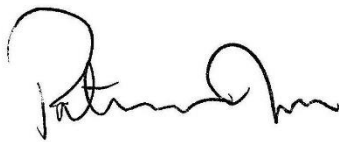

Reviewed by: \_\_\_\_\_  
Patricia Tam, BC Flows and Loads Project Manager

## Introduction

The purpose of this technical memorandum (TM) is to present a summary of applicable nitrogen removal technologies and other technologies that can improve plant capacity to aid in partial or complete nitrogen removal at each of the three large King County (County) wastewater treatment plants (WWTPs). This TM also provides a review of the initial screening criteria developed for eliminating technologies that would not be applicable to a WWTP and summarizes the results of the initial screening meetings held at West Point Treatment Plant (West Point), South Treatment Plant (South Plant), and Brightwater Treatment Plant (Brightwater) to narrow the technologies down to the 5 to 10 technologies that are most applicable to each treatment plant. These will then be further reduced at later workshops to the top two or three technologies for final modeling, sizing, and costing at various effluent N removal conditions to develop a final recommended expansion alternative for each facility.

## Section 1: Technology Review

The purpose of the technology review is to present to the County an exhaustive list of technologies capable of nitrogen (N) removal for possible implementation at each of the County's three large WWTPs. This section describes the technology categories, lists technologies that were pre-eliminated prior to initial screening, and presents a list of the retained technologies for further screening at the screening meetings held at each WWTP.

### 1.1 Technology Categories

To simplify technology screening, each technology was categorized by its implementation type or how it will affect the WWTP, which resulted in five different categories: mainstream, sidestream, tertiary treatment, intensification, and carbon diversion. A description of each of these categories is presented below:

- **Mainstream treatment technologies:** These technologies are employed as the mainstream biological secondary treatment process and must be capable of nitrogen removal.
- **Sidestream treatment technologies:** These technologies are implemented only on the plant biosolids and dewatering streams. They are capable of removing nitrogen in the biosolids/dewatering streams or used to nitrify these streams and seed nitrifiers back to the main process to allow for lower solids retention time (SRT) operation of the mainstream technologies.
- **Tertiary treatment technologies:** These technologies are employed after biological secondary treatment and solids separation. They are used for nitrification and nitrogen removal of the plant effluent after full secondary treatment.
- **Intensification technologies:** These technologies allow for operating the mainstream treatment process in a smaller footprint by allowing for a higher amount of biomass concentration in the same footprint. They do not necessarily remove nitrogen on their own but are used in conjunction with a nitrogen removal mainstream or tertiary treatment process.

**Carbon diversion technologies:** These technologies remove excess biochemical oxygen demand (BOD) from influent wastewaters prior to secondary treatment. This process allows for operating secondary treatment processes in a smaller footprint (due to reduced biomass growth) with less energy (due to diverting BOD away from aerobic processes) to accommodate for nitrogen removal. These technologies also put additional solids into digestion processes and can allow for additional biogas generation for resource recovery or reuse.

## 1.2 Pre-Eliminated Technologies

Prior to each initial screening meeting, several technologies were pre-eliminated for various reasons. This section briefly discusses each of the pre-eliminated technologies and the reason for elimination.

### 1.2.1 Mainstream Processes

**Conventional sequencing batch reactor (SBR):** SBR technology operates with react and settle processes in a single tank, eliminating the need for clarification. In addition, aeration cycling during fill and react periods can provide for some level of denitrification. However, this technology was eliminated prior to the initial meeting for the following reasons:

- Cost: expensive to retrofit existing systems that aren't currently set up for SBR technology (all plants). It's often not cost-effective for large WWTPs.
- Footprint: there is no significant footprint savings due to the additional reactors required to be online for batch operation.
- Performance: it's frequently subject to filamentous issues due to the nature of SBR operation and foam trapping designs.

**Hybrid activated sludge/aquaculture treatment:** This technology combines a conventional activated sludge treatment process with aquaculture treatment by growing aquaculture vegetation on covers over the activated sludge process. The benefit is a reduced footprint (minor) due to some plant uptake of nutrients and a biofilm that grows on the plant root systems. This technology is marketed by Organica Water and has been installed at many facilities around the world (only one in North America in British Columbia, Canada). Most systems are small on-site treatment facilities, but there is a large system in Hungary (~20 million gallons per day [mgd]). This technology was eliminated from further consideration prior to the initial meeting for the following reasons:

- Nitrogen removal: still requires converting to conventional nitrogen removal process like Modified Ludzack-Ettinger (MLE) to achieve adequate nitrogen removal
- Cost: expensive retrofit
- Footprint: minimal footprint benefit
- Maintenance access: completely covered tanks result in access issues
- Status: inventive, lack of installations in the U.S.

**Multi-stage nitrogen removal:** Multi-stage nitrogen removal processes are staged reactor systems. A separate treatment process is accomplished in each stage. In the first stage, BOD removal occurs. In the second state, nitrification occurs. In the third stage, denitrification occurs, but it requires external carbon addition. These systems perform well but have large footprints and carbon and energy requirements. This technology was eliminated from further consideration prior to the initial meeting for the following reasons:

- Cost: expensive retrofit
- Footprint: no footprint benefits

### 1.2.2 Tertiary Processes

**Physical/chemical:** Physical/chemical treatment for tertiary nitrogen removal includes three different technologies, which include breakpoint chlorination/oxidation, ammonia stripping, and ion exchange.

Breakpoint chlorination involves dosing hypochlorite at high levels to chemically convert ammonia in the wastewater to nitrogen gas. This conversion occurs typically at chlorine:nitrogen doses of 7:1 on a molar basis.

Ammonia stripping involves heating, altering the water pH, or some combination of the two to convert ionized ammonia (ammonium) to the unionized ammonia form, which is then easily driven off through off-gassing in a stripping tower. This off-gas is then either discharged to the atmosphere, or the ammonia is captured for use as an organic fertilizer. Ammonia stripping has low removal efficiency at water concentrations below 200 milligrams per liter (mg/L) as nitrogen. Ammonia stripping also has high energy demands for heating and chemical cost for pH adjustment.

Ion exchange involves using some type of mineral or engineered media that is able to capture ionized ammonia (ammonium) by exchanging it for another monovalent cation (typically sodium). Zeolyte is a common ion exchange mineral used for this process. Removal efficiencies are impacted by media saturation and age and need to be replaced or recharged when removal efficiency drops.

Physical/chemical nitrogen removal processes were eliminated prior to the initial meeting for the following reasons:

- **Cost:** operation costs associated with these technologies are typically cost prohibitive. In addition, reactor sizing for ion exchange systems can be footprint intensive and expensive. Reactor cost and operation for stripping technologies are also expensive and would require cooling the final effluent prior to discharge due to the high temperatures that are required for efficient stripping.
- **Poor performance/efficiency at low concentrations:** stripping technologies are not efficient at ammonia removal at the low influent wastewater concentrations.
- **Disinfection byproduct formation:** with breakpoint chlorination, high doses of chlorine yield high disinfection byproduct formation.

**Wetlands treatment:** This technology uses engineered wetlands to treat secondary effluent and remove nitrogen. This process was eliminated prior to the initial meeting for the following reasons:

- **Land use:** it requires significant land for constructing the wetland.
- **Uneven/seasonal performance:** nitrogen removal can be uneven, difficult to control, and seasonal, with nitrogen uptake occurring in the summer and release in the winter.

**Alternate discharge:** Alternate discharge encompasses discharge locations other than the existing outfalls to Puget Sound. These discharges would include processes such as water reuse, groundwater discharge, deep well injection, etc. They would have varying degrees of nitrogen requirements, depending on the use and discharge location. These alternates were not considered as part of this project as they are not a technology and not within the current project scope. However, the County may consider these alternatives as part of a strategic plan to reduce overall nitrogen discharged to Puget Sound and increase water re-use.

**Filtration:** Filtration technologies encompass a range of filter media types, including sand, cloth, and various membrane types. These technologies are used to remove fine particulates from the final effluent prior to discharge. Without using filtration in conjunction with other ammonia or nitrogen removal technologies, they only remove particulate nitrogen (unless operated as biologically active filters for nitrification or denitrification, which are being evaluated separately as tertiary nitrifying/denitrifying fixed-film process). Filtration can be used to enhance nitrogen removal already completed by other technologies. For this reason, conventional filtration technologies are not developed as a two-page summary but will be considered as add-on technologies dependent on the level of effluent nitrogen required for the various options developed.

## 1.3 Retained Technologies

The following is a list of retained technologies for further screening specific to each treatment plant that were evaluated at later workshops with the County. These were then further screened during these





workshops to reduce the technologies to no more than ten for later evaluation. A two-page description of these technologies are provided in Attachment A.

### **1.3.1 Mainstream Processes**

- Modified Ludzack-Ettinger (MLE) Four-stage modified Bardenpho (4SMB)
- Simultaneous Nitrification/Denitrification (SND)
- Anammox
- Aerobic granular sludge

### **1.3.2 Sidestream Processes**

- Anammox
- Shortcut nitrogen removal
- Bioaugmentation
- Post aerobic digestion (PAD)
- Physical/chemical nitrogen recovery

### **1.3.3 Tertiary Processes**

- Nitrifying fixed film
- Denitrifying fixed film
- Anammox polishing
- Algae treatment
- Encapsulation/engineered biomass

### **1.3.4 Intensification Processes**

- Membrane bioreactor (MBR)
- Integrated fixed-film activated sludge (IFAS)
- Fixed film (BAF)
- Ballasted sedimentation
- Hybrid fixed-film/ballast
- Partial granulation
- Membrane aerated biofilm reactor (MABR)

### **1.3.5 Carbon Diversion Processes**

- Chemically enhanced primary treatment (CEPT)
- Primary filtration

## **Section 2: Initial Screening of Technologies**

The initial phase of this task is to pre-screen the retained technologies described in Attachment A down to 10 or fewer for each facility prior to the next phase. This section describes the initial screening assumptions and process used for each WWTP. The results of the initial screening workshops are presented in Section 3 of this TM.



## 2.1 Initial Screening Criteria

Brown and Caldwell (BC), in conjunction with the County, developed a list of criteria to be used for initial screening of the technologies described in Section 1 of this TM. The original intent was to develop a series of pass/fail criteria, but as the team progressed, it determined that an entirely pass/fail criteria list was not possible given the criteria important to the County. Therefore, the below list of criteria was developed, with several having the potential for failure.

- Technology status
- Scalability
- Effluent nitrogen concentration
- Load variation impact
- Flow variation impact
- Footprint
- Impacts to other processes
- Truck traffic
- Energy use
- Greenhouse gas (GHG) emissions
- Resource recovery
- Capital cost
- Operations and maintenance (O&M) cost
- Constructability
- Operational complexity

The criteria list was ranked qualitatively based on the descriptions provided below. No modeling, sizing, layouts, or capital costs were developed for the options evaluated but they will be completed later for the final selected options for each facility.

### 2.1.1 Technology Status

Technology status refers to how well established the technology is in the industry. Established technologies, which have been in operation full-scale for longer than 10 years and have more than five installations, are rated as a qualitative level 3. Innovative technologies which have only been developed in the last 10 years and have fewer than five full-scale installations are rated 2. Embryonic technologies that have only recently begun full-scale operation or are only in lab or pilot scale are rated as a 1. Embryonic technologies that the team believes are more than 5 years from full-scale implementation are rated as “FAIL.”

### 2.1.2 Scalability/Large Scale Operating History

Scalability refers to the operating history/ability of a technology to be implemented at large-size WWTPs. A rating of 3 means that the technology has been implemented or can readily scaled to WWTPs larger than 20 mgd. A rating of 2 has been implemented at WWTPS between 1 and 20 mgd, and a rating of 1 is for technologies only implemented at WWTPs less than 1 mgd.

### 2.1.3 Effluent Nitrogen Concentration

Effluent nitrogen concentration refers to the ability of a technology to remove nitrogen. A 3 rating refers to technologies capable of achieving effluent total inorganic nitrogen (TIN) concentrations less than 5 mg/L. A



2 rating refers to those technologies capable of achieving effluent TIN limits between 5 and 12 mg/L. A rating of 1 includes those technologies that achieve an effluent TIN of > 12 mg/L.

#### **2.1.4 Load Variation Impact**

Load variation refers to the change in influent load either throughout the day or during storm events. The ratings of 1–3 for this criterion are based on a sliding scale for the impact, with 1 being a large impact to the footprint to handle large variations (or an inability to manage large variation, regardless of footprint), 2 being moderate impact, and 3 being minor to no impact (or ability to handle load changes with relative minor impact to WWTP operations).

#### **2.1.5 Flow Variation Impact**

Flow variation refers to the change in influent flow either throughout the day or during storm events. The ratings of 1–3 for this criterion are based on a sliding scale for the impact, with 1 being a large impact to the footprint to handle large variations (or an inability to manage large variation, regardless of footprint), 2 being moderate impact, and 3 being minor to no impact (or ability to handle flow changes with relative minor impact to WWTP operations).

#### **2.1.6 Footprint**

Footprint refers to the impact of a technology to the WWTP footprint. A rating of 1 has a large impact to the footprint, 2 has a moderate impact to the footprint, and 3 has a minor or no impact to the WWTP footprint.

#### **2.1.7 Impacts to Other Processes**

This criterion refers to potential impacts to other treatment processes within the WWTP. For instance, several options may significantly increase biosolids production or negatively impact disinfection systems. The ratings 1–3 refer to the potential impact to other processes, with a 1 having the highest negative impact and 3 having the least or potentially positive impact.

#### **2.1.8 Truck Traffic**

This criterion refers to the increase in number of trucks entering and leaving a facility. These trucks could be for additional biosolids generated by a technology or increased chemical delivery. The ratings have 1 being the highest impact to truck traffic and 3 being the lowest impact.

#### **2.1.9 Energy Use**

For energy use, the ratings are used as follows: 1 is significantly higher energy use, 2 is moderately higher energy use, and 3 is a small increase in energy use, or even a potential net benefit for digester gas generation for energy production.

#### **2.1.10 Greenhouse Gas Emissions**

GHG sources for wastewater treatment come from increased energy use, increased chemical use, and potential for nitrous oxide emissions from denitrification processes. As an example, SND processes have significant potential for nitrous oxide emissions so would rate low (1) for GHG emissions, even though they do have the potential for reduced energy (blower) and chemical (methanol) uses. Likewise, carbon diversion processes that have the potential for increasing biogas generation would potentially have a 3 rating for WWTPs that have cogeneration.

### **2.1.11 Resource Recovery**

Resource recovery options include reclaimed water, additional gas generation for reuse, and capture of nutrients as fertilizer product. Rankings were applied to technologies that would have a net benefit for resource recovery options (3) to net negative (reduced) potential for resource recovery options (1). A ranking of 2 was given to options that do not influence the potential for resource recovery.

### **2.1.12 Capital Cost**

Capital cost rankings were completed on a sliding scale relative to other technologies within the categories (e.g., mainstream, sidestream, etc.) based on BC's experience with these technologies at other facilities. A 3 ranking is the relative lowest cost to implement while a 1 would be the relative highest cost. Multiple technologies could have the same ranking if they have similar costs to implement.

### **2.1.13 Operations and Maintenance Cost**

O&M cost rankings were completed on a sliding scale relative to other technologies within the categories (e.g., mainstream, sidestream, etc.) based on BC's experience with these technologies at other facilities. O&M costs include increased energy use, increased labor (full time employees), and increased chemical use. A 3 ranking is the relative lowest cost to operate while a 1 would be the relative highest cost. Multiple technologies could have the same ranking if they have similar costs to operate.

### **2.1.14 Constructability**

Constructability rankings were completed on a sliding scale relative to other technologies within the categories (e.g., mainstream, sidestream, etc.) based on BC's experience with these technologies at other facilities. Constructability refers to the ease of building while minimizing impacts to facility operation and the ability to meet current permit limits. A 3 ranking is the relative easiest to construct while a 1 would be the relative hardest or have the most potential impact on current operation. Multiple technologies could have the same ranking if they have similar constructability.

### **2.1.15 Operational Complexity**

Operational complexity refers to the ease of the O&M process. For example, a conventional system expansion that uses technology (blowers, mixers, etc.) similar to what the current process at the WWTP uses would have low operational complexity and be rated a 3. A process that requires significantly more equipment for maintenance, equipment that requires more frequent maintenance, or a process that is more complex to operate and requires additional instrumentation or monitoring to ensure process stability would be ranked a 1.

## Section 3: Initial Screening Meeting Summaries

An initial screening workshop was held at each WWTP to review potential nitrogen removal technologies/processes against the initial screening criteria and select up to 10 technologies to carry forward for detailed review/screening in a future workshop (one for each WWTP). A draft screening criteria matrix was developed for each initial screening workshop and was used to help select preferred technologies. Each screening criteria matrix was edited during the workshops and updated based on input from County staff. The final screening criteria matrix for each WWTP is provided in Attachment B. This section summarizes the selected technologies for each WWTP and provides a brief justification of why each technology was either selected or eliminated.

### 3.1 Application of Screening Criteria

The criteria developed for the workshops were applied separately to each technology for each WWTP using the matrix shown below for each facility. The tables were used to qualitatively apply rankings to each of the technologies evaluated using the 1-3 or FAIL ranking applied for each criterion and was used to help facilitate the pre-selection meetings held for each treatment facility.

### 3.2 West Point

The West Point initial screening workshop was held on March 19, 2019. During this workshop, the screening criteria were applied to the various technologies and ranked as shown in Figure 1.



Screening Criteria <sup>1</sup>	Mainstream					Sidestream					Tertiary					Intensification						Carbon Diversion		
	Modified Ludzack-Ettinger (MLE)	Four-Stage Modified Bardenpho (4SMB)	Simultaneous Nitrification-Denitrification (SND)	Anammox	Aerobic Granular Sludge	Anammox	Shortcut N Removal	Bioaugmentation	Post Aerobic Digestion (PAD)	Ammonia Recovery Processes (Phys/Chem)	Nitrifying Fixed Film Processes	Denitrification Fixed Film Processes	Anammox Polishing Process	Algae Treatment	Encapsulation/Engineered Biomass	Membrane Bioreactor (MBR)	Integrated Fixed-Film Activated Sludge (IFAS)	Fixed Film	Ballasted Sedimentation (BioMag®)	Hybrid Fixed-Film/Ballast	Partial Granulation	Membrane Aerated Biofilm Reactor (MABR)	Chemically Enhanced Primary Treatment (CEPT)	Primary Filtration
Technology status <sup>2</sup>	3	3	3	Fail	2	3	3	3	2	Fail	3	3	Fail	1	Fail	3	3	3	2	2	2	2	3	3
Scalability to large WWTP	3	3	3	1	2	3	3	3	3	1	3	3	1	1	1	3	3	3	2	Fail	3	2	3	2
Effluent N concentration	2	3	3	1	3	1	1	1	1	1	1	3	1	3	3									
Load variation impact	2	2	2	1	2						2	3	1	2		2	2	2	2	2	2	2	3	3
Flow variation impact	2	2	2	1	1						2	2	1	2		1	1	1	3	3	2	2	3	2
Footprint <sup>3</sup>	1	1	1	1	3	3	2	2	1	2	1	2	2	Fail	3	3	2	2	3	2	2	2	3	3
Impacts to other processes <sup>4</sup>	3	3	3	2	1	3	3	3	3	2	3	3	3	3	3	2	2	2	2	2	3	2	1	2
Truck traffic	2	2	1	2	2	2	2	2	3	1	2	1	2	2	2	2	2	2	2	2		2	1	2
Energy use	2	2	3	3	3	3	2	2	1	1	1	1	3	2	2	1	1	2	2	2	3	2	3	3
GHG emissions	2	2	1	2	2	2	1	2	2	1	2	2	2	2	2	2	2	1	2	2	2	2	2	3
Resource recovery <sup>5</sup>	2	2	2	2	2	2	2	2	2	3	2	2	2	3	2	3	2	2	2	2	2	2	3	3
Capital cost <sup>6</sup>	2	2	2	2	1	2	2	3	1	1	1	2	2	1	1	1	2	1	1	2	3	1	2	1
O&M cost	3	2	3	3	3	3	2	2	2	1	1	1	3	2	2	1	1	2	2	2	2	2	1	2
Constructability	1	1	1	1	1	2	2	2	1	2	1	2	2	1	1	2	1	1	2	1	3	2	3	2
Operational complexity	3	3	2	1	2	2	1	3	2	1	3	2	1	2	2	2	2	2	2	2	3	1	3	2
<b>Overall</b>	<b>33</b>	<b>33</b>	<b>32</b>	<b>Fail</b>	<b>30</b>	<b>31</b>	<b>26</b>	<b>30</b>	<b>24</b>	<b>Fail</b>	<b>28</b>	<b>32</b>	<b>Fail</b>	<b>Fail</b>	<b>Fail</b>	<b>28</b>	<b>26</b>	<b>26</b>	<b>29</b>	<b>Fail</b>	<b>32</b>	<b>26</b>	<b>34</b>	<b>33</b>

Notes:

- Scale of 1 to 3, where 3 represents the greatest benefit or lowest cost, footprint, emissions, etc.
- Fail if the technology is not expected to be proven at full scale within the next five years, the technology presents too much risk, etc.
- Fail if it is clear that the technology will not be able to fit on the WWTP site.
- Fail if the technology will have unacceptable impacts to other plant processes or impacts that will be difficult to accommodate.
- Resource recovery includes nutrient recovery (N or P), flexibility for future reclaimed water production (TN limits, filtration, etc.), energy recovery, etc. "1" indicates detrimental to resource recovery, "2" indicates no impact to potential for resource recovery, "3" indicates some benefit to resource recovery inherent in the technology.
- Mainstream capital cost assumes additional tankage and no intensification. If intensification is added, this has the potential to decrease capital cost.

Figure 1. West Point technology review with screening criteria rankings



Based on the discussion during the workshop and the results of this screening ranking from Figure 1, the team selected a total of seven technologies to carry forward for detailed screening; biological aerated filter (BAF) was later added as an eighth alternative. Table 1 summarizes the technologies discussed and provides the justification for selection or elimination of each technology for West Point that was determined during the workshop.

Table 1. Technology Pre-Screening Summary for West Point		
Technology	Classification	Justification/notes
<b>Selected technologies</b>		
MLE	Mainstream	MLE is an established technology that can achieve effluent TIN less than 8 mg/L. To be applied at West Point, it would need to be combined with an intensification process to reduce the footprint.
4SMB	Mainstream	4SMB is an established technology that can achieve effluent TIN less than 3 mg/L with supplemental carbon addition. To be applied at West Point, it would need to be combined with an intensification process to reduce the footprint.
Anammox	Sidestream	Of available sidestream nitrogen removal technologies, anammox is the most established and is expected to have the lowest O&M costs.
Bioaugmentation	Sidestream	Bioaugmentation would have higher energy costs than anammox but is being carried forward because of the potential to shrink the mainstream process footprint.
MBR	Intensification	MBR would be used with either MLE or 4SMB to reduce the footprint. MBR can provide a greater footprint reduction than other intensification technologies but would have high capital and O&M costs.
Partial granulation	Intensification	Partial granulation would be used to reduce the footprint of a mainstream process (MLE or 4SMB). It also aligns with current County/University of Washington (UW) pilot work.
Fixed film (BAF)	Intensification	BAF will be considered as an alternative to MBR for intensification, but the viability of operating BAF in SND mode will need to be confirmed.
CEPT	Carbon diversion	Year-round CEPT will be considered to reduce BOD loading to the mainstream secondary process to reduce footprint requirements. CEPT can be retrofitted for the existing primary clarifiers but will have high chemical costs and impacts to the solids handling processes.
<b>Eliminated technologies</b>		
SND	Mainstream	SND can significantly reduce energy costs but was eliminated primarily because of O&M complexity and potentially higher mainstream footprint requirements (reduced nitrification kinetics).
Anammox	Mainstream	Mainstream anammox is still an emerging technology and was failed based on current technology status. Mainstream anammox still has lots of unknowns, and there are no current commercial vendors offering the technology.
Aerobic granular sludge	Mainstream	Aerobic granular sludge (e.g., AquaNereda®) was eliminated because it would require converting to an SBR configuration and would be difficult to apply at West Point because of high peak flows (likely would need to operate with large equalization tanks and/or base-load the granular sludge SBR process).
Shortcut nitrogen removal	Sidestream	Shortcut nitrogen removal was eliminated in favor of sidestream anammox, which is considered a more beneficial sidestream nitrogen removal technology (lower O&M costs, complexity, and GHG emissions).
PAD	Sidestream	PAD was eliminated because it is not an established technology and would increase footprint requirements for digestion, which is not available (new tankage for aerobic digesters).
Ammonia recovery	Sidestream	Ammonia recovery was failed primarily based on technology status (no current known municipal installations and only one known commercial vendor remaining), increased



Table 1. Technology Pre-Screening Summary for West Point		
Technology	Classification	Justification/notes
		truck traffic at West Point (chemical deliveries and fertilizer production), and high capital/O&M costs.
Nitrifying fixed film	Tertiary	Tertiary fixed-film processes were eliminated because of high footprint requirements that are unlikely to work with the West Point site.
Denitrifying fixed film	Tertiary	Tertiary fixed-film processes were eliminated because of high footprint requirements that are unlikely to work with the West Point site.
Anammox polishing	Tertiary	Anammox polishing was failed based on technology status. It would also have complex O&M.
Algae treatment	Tertiary	Algae treatment was failed because of high footprint requirements (would not fit on the West Point site). The technology would also be difficult and cost-prohibitive to scale to the capacity required for West Point.
Encapsulation/engineered biomass	Tertiary	Encapsulation/engineered biomass was failed based on technology status (still an embryonic technology with no full-scale installations).
IFAS/MBBR	Intensification	IFAS/MBBR technologies were eliminated because they would not be able to provide the same footprint savings as MBR so are even less likely to fit on the West Point site.
Ballasted sedimentation	Intensification	Ballasted sedimentation (BioMag®) can provide similar aeration basin footprint savings to MBR but still would require secondary clarifiers. It was primarily eliminated based on concerns over scalability to the capacity required for West Point (high number of units required for magnetite recovery equipment) and increased truck traffic for magnetite deliveries.
Hybrid fixed-film/ballast	Intensification	Hybrid fixed-film/ballast processes were failed based on the lack of current municipal installations, particularly for large WWTPs. The technology is also not expected to provide the same footprint savings as MBR.
MABR	Intensification	MABR was primarily eliminated because of footprint constraints at West Point (not expected to provide substantial footprint savings). MABR technology is still developing and there is still some uncertainty in potential energy savings.
Primary filtration	Carbon diversion	Primary filtration was eliminated because CEPT could be more easily retrofitted with the existing primary clarifiers, and primary filtration would still likely need a backup primary clarifier(s) to handle West Point's peak flows.

### 3.3 South Plant

The South Plant initial screening workshop was held on March 21, 2019. During this workshop, the screening criteria were applied to the various technologies and ranked as shown in Figure 2.





Screening Criteria <sup>1</sup>	Mainstream					Sidestream					Tertiary					Intensification					Carbon Diversion		
	Modified Ludzack-Ettinger (MLE)	Four-Stage Modified Bardenpho (4SMB)	Simultaneous Nitrification-Denitrification (SND)	Anammox	Aerobic Granular Sludge	Anammox	Shortcut N Removal	Bioaugmentation	Post Aerobic Digestion (PAD)	Ammonia Recovery Processes (Phys/Chem)	Nitrifying Fixed Film Processes	Denitrification Fixed Film Processes	Anammox Polishing Process	Algae Treatment	Encapsulation/Engineered Biomass	Membrane Bioreactor (MBR)	Integrated Fixed-Film Activated Sludge (IFAS)/ Moving Bed Biofilm Reactor (MBBR)	Ballasted Sedimentation (BioMag®)	Hybrid Fixed-Film/Ballast	Partial Granulation	Membrane Aerated Biofilm Reactor (MABR)	Chemically Enhanced Primary Treatment (CEPT)	Primary Filtration
Technology status <sup>2</sup>	3	3	3	Fail	2	3	3	3	2	Fail	3	3	Fail	1	Fail	3	3	2	2	2	2	3	3
Scalability to large WWTP	3	3	3	1	2	3	3	3	3	1	3	3	1	1	1	3	3	2	Fail	3	2	3	2
Effluent N concentration	2	3	3	1	3	1	1	1	1	1	1	3	1	3	3								
Load variation impact	2	2	2	1	2						2	3	1	2		2	2	2	2	2	2	3	3
Flow variation impact	2	2	2	1	1						2	2	1	2		1	1	3	3	2	2	3	2
Footprint <sup>3</sup>	1	1	1	1	3	3	2	2	1	2	1	2	2	1	3	3	2	3	2	2	2	3	3
Impacts to other processes <sup>4</sup>	3	3	3	2	1	3	3	3	3	2	3	3	3	3	3	2	2	2	2	3	2	1	2
Truck traffic	2	2	1	2	2	2	2	2	3	1	2	1	2	2	2	2	2	2	2	3	2	1	2
Energy use	2	2	3	3	3	3	2	2	1	1	1	1	3	2	2	1	1	2	2	3	2	3	3
GHG emissions	2	2	1	2	2	2	1	2	2	1	2	2	2	2	2	2	2	2	2	2	2	2	3
Resource recovery <sup>5</sup>	2	2	2	2	2	2	2	2	2	3	2	2	2	3	2	3	2	2	2	2	2	3	3
Capital cost <sup>6</sup>	2	2	2	2	1	2	2	3	1	1	1	2	2	1	1	1	2	1	2	3	1	2	1
O&M cost	3	2	3	3	3	3	2	2	2	1	1	1	3	2	2	1	1	2	2	2	2	1	2
Constructability	2	2	2	1	1	3	3	3	3	3	3	3	3	3	3	2	2	3	2	3	2	3	2
Operational complexity	3	3	2	1	2	2	1	3	2	1	3	2	1	2	2	2	2	2	2	3	1	3	2
<b>Overall</b>	<b>34</b>	<b>34</b>	<b>33</b>	<b>Fail</b>	<b>30</b>	<b>32</b>	<b>27</b>	<b>31</b>	<b>26</b>	<b>Fail</b>	<b>30</b>	<b>33</b>	<b>Fail</b>	<b>30</b>	<b>Fail</b>	<b>28</b>	<b>27</b>	<b>30</b>	<b>Fail</b>	<b>35</b>	<b>26</b>	<b>34</b>	<b>33</b>

Notes:

1. Scale of 1 to 3, where 3 represents the greatest benefit or lowest cost, footprint, emissions, etc.

2. Fail if the technology is not expected to be proven at full scale within the next five years, the technology presents too much risk, etc.

3. Fail if it is clear that the technology will not be able to fit on the WWTP site.

4. Fail if the technology will have unacceptable impacts to other plant processes or impacts that will be difficult to accommodate.

5. Resource recovery includes nutrient recovery (N or P), flexibility for future reclaimed water production (TN limits, filtration, etc.), energy recovery, etc. "1" indicates detrimental to resource recovery, "2" indicates no impact to potential for resource recovery, "3" indicates some benefit to resource recovery inherent in the technology.

6. Mainstream capital cost assumes additional tankage and no intensification. If intensification is added, this has the potential to decrease capital cost.

Figure 2. South Plant technology review with screening criteria rankings



Based on the discussion during the workshop, the team selected a total of nine technologies to carry forward for detailed screening. Table 2 summarizes the technologies and provides justification for selection or elimination of each technology for South Plant as discussed during the workshop.

Table 2. Technology Pre-Screening Summary for South Plant		
Technology	Classification	Justification/notes
<b>Selected technologies</b>		
MLE	Mainstream	MLE is an established technology that can achieve effluent TIN less than 8 mg/L. Existing aeration basins at South Plant can be retrofitted for MLE.
4SMB	Mainstream	4SMB is an established technology that can achieve effluent TIN less than 3 mg/L with supplemental carbon addition. Existing aeration basins at South Plant can be retrofitted for 4SMB. Further, swing zones could be used to allow flexibility for operating in other modes, including MLE.
SND	Mainstream	SND can substantially reduce energy costs for operating the mainstream process. It can also be retrofitted for the existing aeration basins at South Plant with updates to the aeration system and specialized aeration controls. SND may be paired with partial granulation (cyclones on the WAS) for settleability improvements.
Anammox	Sidestream	Of available sidestream nitrogen removal technologies, anammox is the most established and is expected to have the lowest O&M costs.
Bioaugmentation	Sidestream	Bioaugmentation will have higher energy costs than anammox but is being carried forward because of the potential to shrink the mainstream process footprint.
Nitrifying/denitrifying fixed film	Tertiary	Nitrifying/denitrifying fixed-film processes will be considered as a combined alternative, which could be added downstream of the existing secondary process. South Plant could also consider locating tertiary fixed-film processes offsite by purchasing new land adjacent to the existing WWTP (this potential advantage was discussed during the workshop).
IFAS	Intensification	IFAS will be considered to reduce mainstream process footprint requirements by allowing nitrification at lower SRTs.
Partial granulation	Intensification	Partial granulation would be used to reduce the footprint of the mainstream process (MLE, 4SMB, or SND). It also aligns with current County/UW pilot work.
MABR	Intensification	MABR technology has the potential to reduce the mainstream process footprint requirements (potential to reduce required SRT) and provide energy savings. Requirements for fine screening to protect the membranes will need to be considered.
<b>Eliminated technologies</b>		
Anammox	Mainstream	Mainstream anammox is still an emerging technology and was failed based on current technology status. Mainstream anammox still has lots of unknowns, and there are no current commercial vendors offering the technology.
Aerobic granular sludge	Mainstream	Aerobic granular sludge (e.g., AquaNereda®) was eliminated because it would require converting to an SBR configuration and would have more difficult constructability at South Plant compared to other mainstream processes (MLE, 4SMB, or SND).
Shortcut nitrogen removal	Sidestream	Shortcut nitrogen removal was eliminated in favor of sidestream anammox, which is considered a more beneficial sidestream nitrogen removal technology (lower O&M costs, complexity, and GHG emissions).
PAD	Sidestream	PAD was eliminated because it is not an established technology and would increase footprint requirements for digestion (new tankage for aerobic digesters).
Ammonia recovery	Sidestream	Ammonia recovery was failed primarily based on technology status (no current known municipal installations and only one known commercial vendor remaining), operator safety concerns (sulfuric acid and high temperature operation), and high capital/O&M costs.
Anammox polishing	Tertiary	Anammox polishing was failed based on technology status. It would also have complex O&M.



Table 2. Technology Pre-Screening Summary for South Plant		
Technology	Classification	Justification/notes
Algae treatment	Tertiary	Algae treatment was eliminated primarily based on scalability concerns for the capacity required for South Plant (largest current CLEARAS installation is 4 mgd, and it is still under construction). It would also have high capital cost and footprint requirements.
Encapsulation/engineered biomass	Tertiary	Encapsulation/engineered biomass was failed based on technology status (still an embryonic technology with no full-scale installations).
MBR	Intensification	Although MBR likely offers the highest footprint reduction for the mainstream process, it was eliminated based on the workshop discussion and County preference to focus on alternative intensification technologies first, such as IFAS or partial granulation, recognizing that the South Plant site has more space available for expansion (albeit at the sacrifice of future expansions for plant capacity).
Ballasted sedimentation	Intensification	Ballasted sedimentation (BioMag®) was primarily eliminated based on concerns over scalability to the capacity required for South Plant (high number of units required for magnetite recovery equipment) and cost of replacement magnetite.
Hybrid fixed-film/ballast	Intensification	Hybrid fixed-film/ballast processes were failed based on the lack of current municipal installations, particularly for large WWTPs. However, IFAS will be considered for South Plant in lieu of hybrid fixed-film/ballast processes.
Fixed Filmm/BAF	Intensification	BAF was eliminated because it would require replacing the existing secondary process at South Plant (or operating as a new parallel treatment train), and South Plant also has footprint availability (unlike West Point).
CEPT	Carbon diversion	CEPT was eliminated because of high chemical requirements and inorganic sludge production. In general, carbon diversion technologies also make less sense for South Plant because of footprint availability.
Primary filtration	Carbon diversion	Primary filtration was eliminated because of high capital cost and the need to replace existing primary clarifiers. In general, carbon diversion technologies also make less sense for South Plant because of footprint availability.

### 3.4 Brightwater

The Brightwater initial screening workshop was held on April 4, 2019.



Screening Criteria <sup>1</sup>	Mainstream					Sidestream					Tertiary				Intensification						Carbon Diversion		
	Modified Ludzack-Ettinger (MLE) - Brightwater currently operates MLE/MBR process	Four-Stage Modified Bardenpho (4SMB)	Simultaneous Nitrification-Denitrification (SND) - selected for optimization project	Anammox	Aerobic Granular Sludge	Anammox	Shortcut N Removal	Bioaugmentation	Post Aerobic Digestion (PAD)	Ammonia Recovery Processes (Phys/Chem)	Nitrifying Fixed Film Processes	Denitrification Fixed Film Processes	Anammox Polishing Process	Algae Treatment	Encapsulation/Engineered Biomass	Membrane Bioreactor (MBR)	Integrated Fixed-Film Activated Sludge (IFAS)/ Moving Bed Biofilm Reactor (MBBR)	Ballasted Sedimentation (BioMag®)	Hybrid Fixed-Film/Ballast	Partial Granulation	Membrane Aerated Biofilm Reactor (MABR)	Chemically Enhanced Primary Treatment (CEPT) - Brightwater currently operates CEPT system	Primary Filtration
Technology status <sup>2</sup>	3	3	3	Fail	Not applicable to Brightwater.	3	3	3	2	Fail	Not applicable to Brightwater.	3	Fail	1	Fail	Brightwater already operates MBR process for intensification. However, partial granulation remains of interest per workshop on 4/4/19 and will be retained for further evaluation. Other intensification technologies are not or would likely not be compatible with MBR technology and are eliminated.						3	3
Scalability to large WWTP	3	3	3	1		3	3	3	3	1		3	1	1	1							3	2
Effluent N concentration	2	3	3	1		1	1	1	1	1		3	1	3	3							3	3
Load variation impact	2	2	2	1								3	1	2								3	3
Flow variation impact	2	2	2	2								2	2	2	2							3	2
Footprint <sup>3</sup>	1	1	1	1		3	2	2	1	2		2	2	1	3							3	3
Impacts to other processes <sup>4</sup>	3	3	3	2		3	3	3	3	2		3	3	3	3							1	2
Truck traffic																							
Energy use	2	2	3	3		3	2	2	1	1		1	3	2	2							3	3
GHG emissions	2	2	1	2		2	1	2	2	1		2	2	2	2							2	3
Resource recovery <sup>5</sup>	2	2	2	2		2	2	2	2	3		2	2	3	2							3	3
Capital cost <sup>6</sup>	2	2	2	2		2	2	3	1	1		2	2	1	1							2	1
O&M cost	3	2	3	3		3	2	2	2	1		1	3	2	2							1	2
Constructability	2	2	2	1		3	3	3	3	3		3	3	3	3							3	2
Operational complexity	3	3	2	1	2	1	3	2	1	2	1	2	2	3	2								
<b>Overall</b>	<b>32</b>	<b>32</b>	<b>32</b>	<b>Fail</b>	<b>N/A</b>	<b>30</b>	<b>25</b>	<b>29</b>	<b>23</b>	<b>Fail</b>	<b>N/A</b>	<b>32</b>	<b>Fail</b>	<b>28</b>	<b>Fail</b>	<b>N/A</b>	<b>N/A</b>	<b>N/A</b>	<b>N/A</b>	<b>N/A</b>	<b>N/A</b>	<b>33</b>	<b>31</b>

Notes:

- Scale of 1 to 3, where 3 represents the greatest benefit or lowest cost, footprint, emissions, etc.
- Fail if the technology is not expected to be proven at full scale within the next five years, the technology presents too much risk, etc.
- Fail if it is clear that the technology will not be able to fit on the WWTP site.
- Fail if the technology will have unacceptable impacts to other plant processes or impacts that will be difficult to accommodate.
- Resource recovery includes nutrient recovery (N or P), flexibility for future reclaimed water production (TN limits, filtration, etc.), energy recovery, etc. "1" indicates detrimental to resource recovery, "2" indicates no impact to potential for resource recovery, "3" indicates some benefit to resource recovery inherent in the technology.
- Mainstream capital cost assumes additional tankage and no intensification. If intensification is added, this has the potential to decrease capital cost.

Figure 3. Brightwater technology review with screening criteria rankings



Based on the discussion during the workshop, the team selected a total of eight technologies to carry forward for detailed screening. However, Brightwater already has two of the technologies installed (MBR and CEPT). In addition, Brightwater currently operates an MLE process for nitrogen removal, but the existing process has an undersized anoxic zone and limited internal mixed liquor recycle capacity. Brightwater is also currently pursuing SND implementation as part of the Brightwater Aeration Basins Optimization (BWABO) Project, though for minimizing operational costs and capital improvements, not to meet a TN objective. Table 3 summarizes the technologies and provides justification for selection or elimination of each technology for Brightwater as discussed during the workshop.

<b>Table 3. Technology Pre-Screening Summary for Brightwater</b>		
<b>Technology</b>	<b>Classification</b>	<b>Justification/notes</b>
<b>Selected technologies</b>		
MLE	Mainstream	Brightwater currently operates an MLE/MBR process. Optimizations to the current MLE process configuration would be considered as part of this study based on effluent nitrogen targets.
4SMB	Mainstream	4SMB can achieve lower effluent nitrogen than MLE, so it may be required for lower effluent nitrogen targets. However, 4SMB would require more extensive retrofits to Brightwater's existing aeration basins than MLE or SND.
SND	Mainstream	SND was recommended for implementation as part of the BWABO project. Preliminary design of SND is currently scheduled to start in May/June 2019, so it makes sense to carry SND forward as part of this study as well.
Anammox	Sidestream	Of available sidestream nitrogen removal technologies, anammox is the most established and is expected to have the lowest O&M costs.
Denitrifying fixed film	Tertiary	Although tertiary treatment makes less sense following the MBR secondary process, tertiary denitrifying fixed-film processes could be used to remove additional nitrogen to meet lower limits (e.g., if nitrogen limits are lower than what can be achieved with the mainstream process or it becomes more viable to add a tertiary process rather than expand the mainstream process).
MBR	Intensification	Brightwater already has an MBR process for intensification. The team assumed that the MBR configuration will be retained.
Partial granulation	Intensification	Impacts/benefits of partial granulation on MBR operation are not yet known, but the technology remains of interest to the County based on the workshop discussion.
CEPT	Carbon diversion	Brightwater currently operates CEPT seasonally. This study would consider seasonal or year-round CEPT.
<b>Eliminated technologies</b>		
Anammox	Mainstream	Mainstream anammox is still an emerging technology and was failed based on current technology status. Mainstream anammox still has lots of unknowns, and there are no current commercial vendors offering the technology.
Aerobic granular sludge	Mainstream	Aerobic granular sludge (e.g., AquaNereda®) was eliminated because it would require replacing the existing MBR process.
Shortcut nitrogen removal	Sidestream	Shortcut nitrogen removal was eliminated in favor of sidestream anammox, which is considered a more beneficial sidestream nitrogen removal technology (lower O&M costs, complexity, and GHG emissions).
Bioaugmentation	Sidestream	Bioaugmentation was eliminated because it would offer minimal benefit for an MBR process. The primary benefit of bioaugmentation is seeding the mainstream process with nitrifiers to allow operation at reduced SRT, but, to maintain performance, the MBR likely needs to be operated at a high SRT regardless.
PAD	Sidestream	PAD was eliminated because it is not an established technology and would increase footprint requirements for digestion (new tankage for aerobic digesters).



**Table 3. Technology Pre-Screening Summary for Brightwater**

Technology	Classification	Justification/notes
Ammonia recovery	Sidestream	Ammonia recovery was failed primarily based on technology status (no current known municipal installations and only one known commercial vendor remaining), operator safety concerns (sulfuric acid and high temperature operation), and high capital/O&M costs.
Nitrifying fixed film	Tertiary	Tertiary nitrifying-fixed film processes were eliminated because MBR processes already require an SRT that promotes full nitrification for filterability, so a tertiary nitrifying process is not applicable to Brightwater.
Anammox polishing	Tertiary	Anammox polishing was failed based on technology status. It would also have complex O&M. It also requires a source of nitrite and ammonia from the secondary process, which will not be compatible with an MBR operated for full nitrification.
Algae treatment	Tertiary	Algae treatment was eliminated primarily based on scalability concerns for the capacity required for Brightwater (largest current CLEARAS installation is 4 mgd, and it is still under construction). It would also have high capital cost and footprint requirements.
Encapsulation/engineered biomass	Tertiary	Encapsulation/engineered biomass was failed based on technology status (still an embryonic technology with no full-scale installations).
IFAS/MBBR	Intensification	Brightwater already operates an MBR process for intensification. Other intensification technologies, except for partial granulation, are not or would likely not be compatible with MBR technology and were eliminated.
Ballasted sedimentation	Intensification	
Hybrid fixed-film/ballast	Intensification	
MABR	Intensification	
BAF	Intensification	
Primary filtration	Carbon diversion	Primary filtration was eliminated because Brightwater already operates a CEPT system. The team noted during the workshop that primary filtration could potentially replace the need for the existing primary effluent screening system.



## Attachment A: Technology Summaries

---



## Four-Stage Modified Bardenpho (4SMB) Configuration

**Classification:** Mainstream

**Process Description:**

The 4SMB process is an expansion of the MLE process that adds a second set of anoxic and aerobic zones. The mixed liquor leaving the first aerobic zone enters a second anoxic zone where the residual nitrate is further reduced via denitrification. Most frequently, because the soluble carbon has been consumed in the previous two zones, an external carbon source (e.g., methanol) is added to the second anoxic selector to achieve a higher level of . The second aerated zone serves as a polishing step to nitrify the ammonia formed in the second anoxic zone and to oxidize any residual carbon from the second anoxic zone.

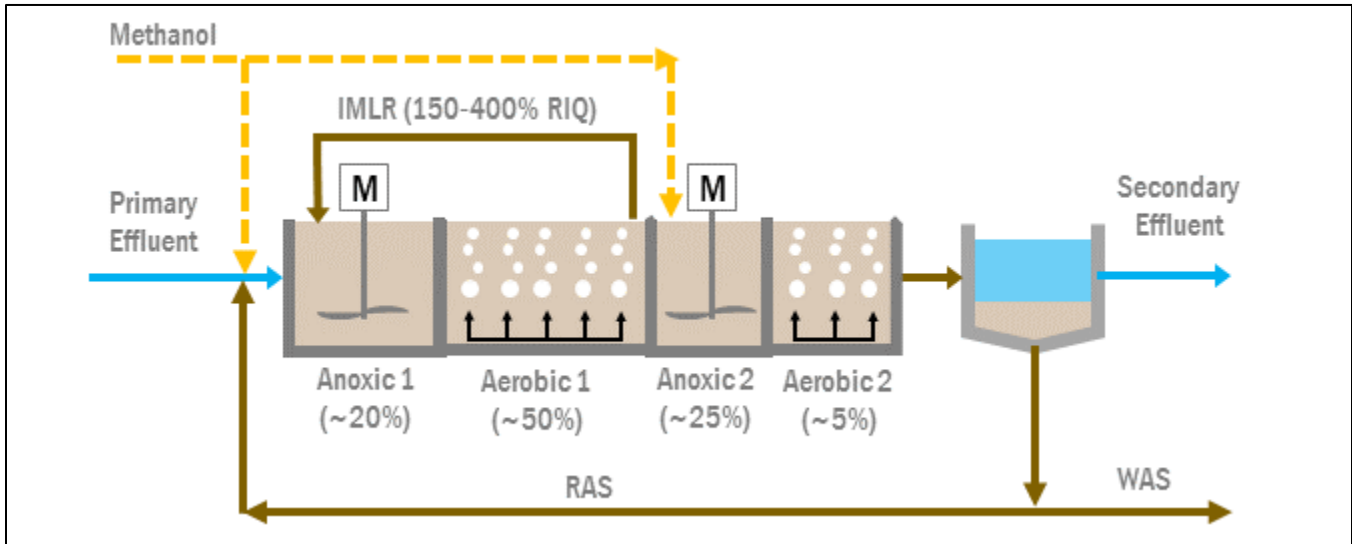

Process flow diagram

**Status:** Established

Number of Installations		
Full scale	Pilot scale	Lab scale
> 50	N/A	N/A

**Reference Installations (Up to Five):**

1. Chambers Creek WWTP, Pierce County, WA (45 mgd peak month design flow) – 4SMB is intended to be primary mode of operation when N removal is required, but can also operate in other modes, including MLE.
2. Central Kitsap Treatment Plant, Kitsap County, WA (8.2 mgd peak month design flow) – 4SMB is intended to be primary mode of operation, but can also operate in other modes, such as MLE or anaerobic selector mode.
3. LOTT Budd Inlet Treatment Plant, Olympia, WA (11 mgd average)
4. Marlay Taylor Water Reclamation Facility, Ocean City, MD (6 mgd average, 4SMB with BioMag)
5. Boulder, CO (25 mgd)

**Estimated Time to Full Scale:** N/A



## Key Considerations:

### Practicality of Scaling Technology to Large WWTP: High

Potential Impacts of Technology					
Parameter	Low	Medium	High	Season	Notes
Effluent N concentration benefit			✓	Year-round	Capable of meeting low N limits with supplemental carbon addition
Footprint impact			✓		Large footprint required for conventional process
Impacts to other plant processes	✓				
Truck traffic impact		✓			
Sustainability					
Energy use		✓			Aeration for nitrification and IMLR pumping
GHG emissions		✓			Similar to MLE, but typically increased chemical demand where 4SMB is targeting a lower effluent N concentration and supplemental carbon dosing is required.
Resource recovery benefit		✓			Potential to meet TN limits (down to 10 mg/L) for re-claimed water production
Relative capital cost		✓			Large footprint but no proprietary equipment/processes
Relative O&M cost		✓			Potential for high chemical costs for external carbon
Operational complexity	✓				

#### Other Notable Characteristics:

- Simple, reliable process
- Can be paired with intensification and/or sidestream treatment processes to reduce footprint
- Aeration basins can be configured with swing zones to allow flexibility to change anoxic volume fractions or operate in alternative modes depending on N removal requirements

#### Known Issues/Risks:

- Potential for biological foaming at longer SRTs required for N removal (can be mitigated with foam control methods)

**Applicable KC WTD Plants:**  West Point  South Plant  Brightwater

# Anammox

**Classification:** Mainstream

**Process Description:**

Anammox-based mainstream treatment processes can be used to remove nitrogen from settled and partially treated wastewater streams via a shortcut process that reduces overall aeration and alkalinity requirements, while also eliminating carbon demands for denitrification. The shortcut involves allowing only partial nitrification under aerobic conditions, where approximately half of the ammonium is converted to nitrite, followed by anaerobic conversion of ammonium to nitrogen gas using Anammox bacteria. In contrast to a typical denitrification process, where an external carbon source is required to convert nitrate/nitrite to nitrogen gas, the Anammox bacteria can remove ammonia under anaerobic conditions using nitrite as the electron acceptor and carbon dioxide as the carbon source. There are several commercially available processes that utilize Anammox bacteria for sidestream treatment, but current mainstream anammox experience is much more limited, with two known full-scale installations.

As anammox requires a low carbon-to-nitrogen (C:N) ratio in the wastewater, BOD must be removed prior to the anammox reactor. This means that mainstream anammox must be operated in an A Stage/B Stage configuration. The A Stage reactor removes BOD only (65–80 percent of BOD), which reduces the C:N ratio to approximately 3–5 to avoid/limit competition for nitrite between ordinary heterotrophic organisms and anammox bacteria in the B stage reactor. The B stage reactor is a separate activated sludge process that needs to be operated to create conditions for anammox bacteria to work, usually by controlling ammonia and nitrite (or oxidized nitrogen) at equal concentrations in the reactor. Anammox bacteria captured in the B-stage solids separation system is only returned to the B-stage reactor. The B stage reactor needs to be bio-augmented with anammox bacteria (either from sidestream treatment or MBBR) to accomplish nitrogen removal.

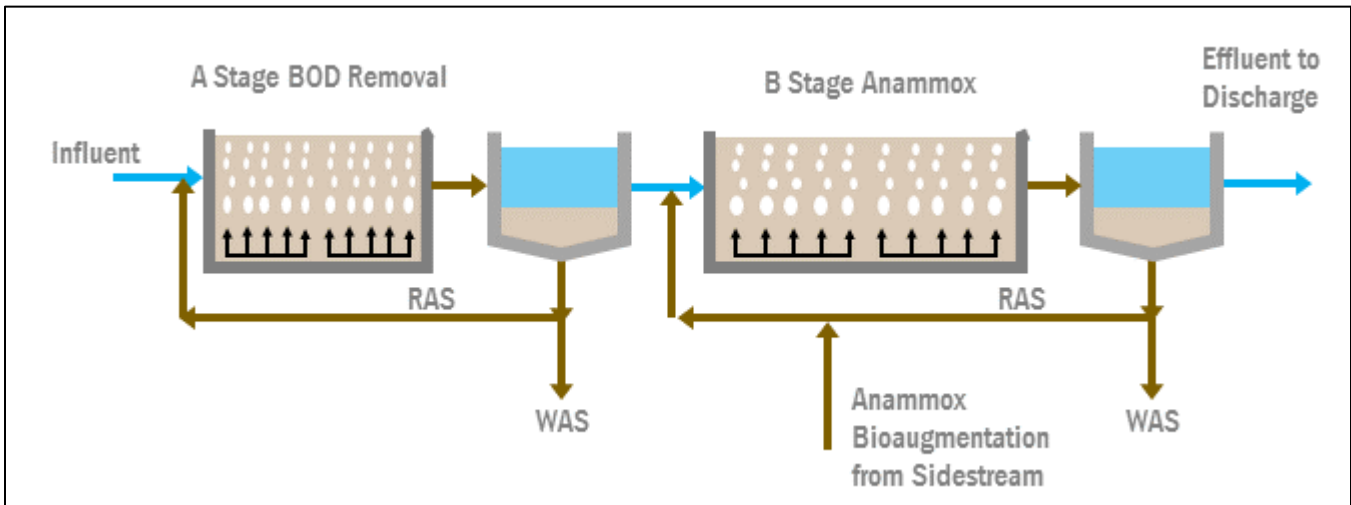

Process flow diagram (mainstream Anammox with bioaugmentation from sidestream treatment)

**Status:** Innovative

Number of Installations		
Full scale	Pilot scale	Lab scale
2	Multiple	Multiple

**Reference Installations (Up to Five):**

1. Strass WWTP, Austria (10 mgd) – operating mainstream anammox for approximately five years
2. Changi, Singapore (50 mgd) – claimed to operate mainstream anammox for approximately three years

**Estimated Time to Full Scale:** N/A

## Key Considerations:

### Practicality of Scaling Technology to Large WWTP: Low

Potential Impacts of Technology					
Parameter	Low	Medium	High	Season	Notes
Effluent N concentration benefit		✓		Year-round	Strass WWTP is meeting effluent TN of approximately 5 mg/L, but N removal performance is highly dependent on successful operation of the B stage anammox process.
Footprint impact			✓		Potential to reduce required size of mainstream basin expansion for N removal.
Impacts to other plant processes		✓			Increases overall solids production due to A stage reactor configuration. May require upgrade to digestion and/or biogas handling systems. Likely requires side-stream anammox for bioaugmentation.
Truck traffic impact		✓			
Sustainability					
Energy use	✓				Aeration demand reductions as complete nitrification is not needed. Increased biogas for energy generation.
GHG emissions		✓			Lower electricity and carbon requirements compared to other N removal technologies. Exact impact of greenhouse gas emissions is unknown for Anammox, but some research suggests minimal N <sub>2</sub> O emissions.
Resource recovery benefit					No negative impact on resource recovery options. A stage reactor increases biogas production. Potential to meet reclaimed water limits for TN (down to < 30 mg/L)
Relative capital cost		✓			Exact cost unknown, but may be lower than complete upgrade to 4 Stage Bardenpho
Relative O&M cost	✓				Aeration and carbon demand reductions compared with other N removal technologies
Operational complexity			✓		

#### Other Notable Characteristics:

- Anammox seed sludge required for system startup
- Requires heavy use of instrumentation/sensors (e.g. ammonia, nitrate, DO and pH probes needed)
- Requires A Stage/B Stage reactor configuration

#### Known Issues/Risks:

- Limited full-scale installations
- Anammox less efficient at lower operating wastewater temperatures
- Limit in maximum ammonia removal
- May be expensive when proprietary systems are commercially available

**Applicable KC WTD Plants:**  West Point  South Plant  Brightwater

# Aerobic Granular Sludge

**Classification:** Mainstream

## **Process Description:**

Aerobic granular sludge processes select for dense sludge floc that retained and allowed to grow to generate pellets that have fast settling rates, which allows operation at high MLSS concentrations and shrinks process footprint. Mature granules are typically 1–2 mm in diameter and are composed of a diverse population of microorganisms. With proper DO control, under aerated conditions, the granule will have aerobic, anoxic, and anaerobic conditions occurring within different layers of the structure. Granule formation relies on hydraulic selection for fast settling particles and biological selection for microorganisms that produce extracellular polymeric substances (EPS), which is the backbone of the granule structure. Hydraulic selection is based on selective wasting with a short settling time, which selects for granules that settle faster than conventional activated sludge flocs. Biological selection focuses on selecting for polyphosphate accumulating organisms (PAOs) and glycogen accumulating organisms (GAOs), which produce EPS; PAOs also aid in formation of a precipitate core.

The aerobic granular sludge technology was developed in the Netherlands by Royal HaskoningDHV during the 1990's and sold commercially in Europe as the Nereda process. The first full-scale Nereda process was constructed in 2005 at an industrial WWTP and the first full-scale municipal Nereda process was constructed in 2009. Aqua Aerobics is currently the exclusive supplier of Nereda technology in North America (through a 2016 licensing agreement with Royal HaskoningDHV), marketed as AquaNereda®.

Nereda operates an SBR process that uses three cycles:

1. **Fill/draw:** Influent wastewater enters the bottom of the tank, which displaces effluent over fixed weirs at the top of the tank. The tank is unaerated during this phase. The influent wastewater creates a high concentration of readily available carbon in the sludge blanket of the reactor under anoxic/anaerobic conditions, which promotes selection of PAOs/GAOs.
2. **React:** Influent flow is stopped and the reactor is intermittently aerated, creating cyclical aerobic/anoxic conditions and promoting simultaneous nitrification-denitrification (SND).

**Settle:** Aeration is turned off and the granules settle to the bottom of the reactor. Sludge is wasted from near the top of the blanket to remove lighter material and select for faster-settling granules.

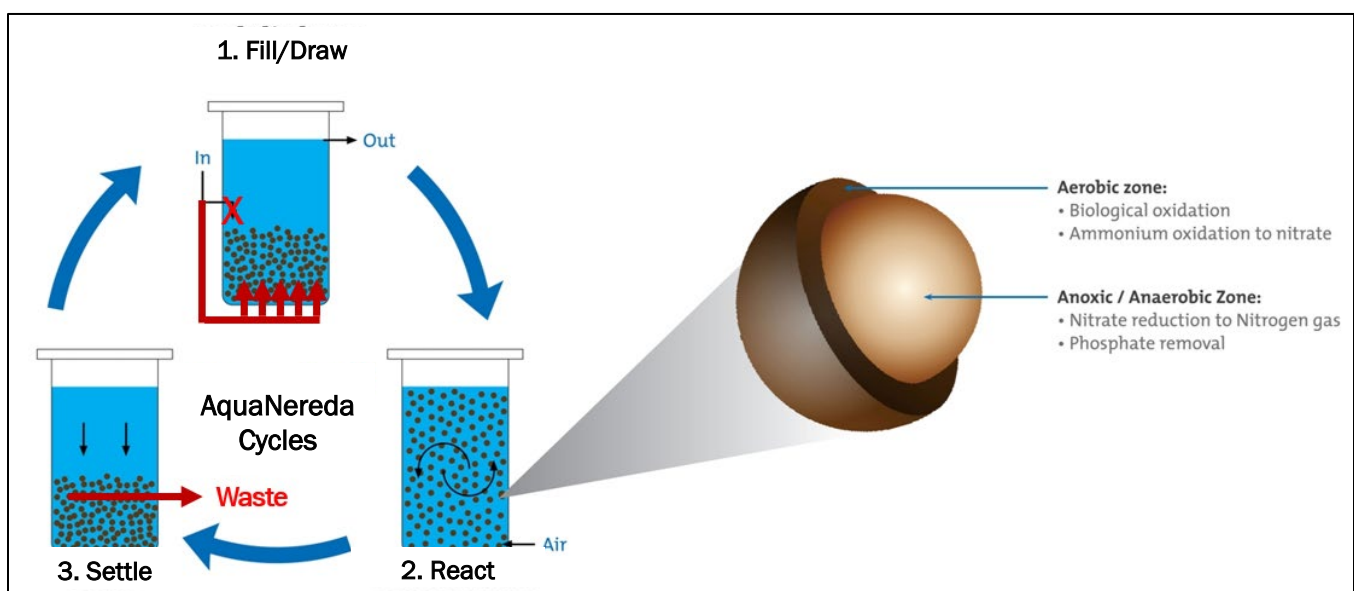

**AquaNereda SBR cycles and reactions within granule**

*Adapted from Aqua Aerobics AquaNereda brochure.*

**Status:** Innovative (many Nereda installations worldwide but new to North America, and other continuous-flow systems for granular sludge are still emerging technologies)

Number of Installations		
Full scale	Pilot scale	Lab scale
> 30 (worldwide)	Various North America pilots	N/A

### Reference Installations (Up to Five):

1. Epe, Netherlands (2.1 mgd average, 9.5 mgd peak)
2. Kingaroy, Australia (0.71 mgd average, 2.85 mgd peak)
3. Rio de Janeiro, Brazil (22.8 mgd average, 38.8 mgd peak)
4. Ringsend, Ireland (159 mgd average, 314 mgd peak)
5. Rock River Water Reclamation District, Rockford, IL (0.3-mgd demonstration pilot)

**Estimated Time to Full Scale:** N/A

### Key Considerations:

**Practicality of Scaling Technology to Large WWTP:** Medium

Potential Impacts of Technology					
Parameter	Low	Medium	High	Season	Notes
Effluent N concentration benefit			✓	Year-round	Capable of achieving very low effluent TN and TP
Footprint impact	✓				Claim 25–40 percent of 5-stage BNR footprint and eliminates need for secondary clarifiers
Impacts to other plant processes			✓		Influent and sludge wasting EQ tank considerations, plus potential digestion/dewatering impacts with bio-P sludge
Truck traffic impact		✓			
Sustainability					
Energy use	✓				Claim 40–50 percent energy savings
GHG emissions		✓			Lower overall electricity and carbon requirements. Exact impact of granular sludge operation on N <sub>2</sub> O emissions is unclear but some research suggests low emissions of N <sub>2</sub> O.
Resource recovery benefit		✓			Potential for P recovery if performing bio-P. Capable of meeting reclaimed water TN limits (< 10 mg/L)
Relative capital cost			✓		High capital cost for proprietary equipment and licensing fees
Relative O&M cost	✓				Energy savings
Operational complexity		✓			

### Other Notable Characteristics:

- Nereda granules are fast settling (SVI5 similar to SVI30 of typical activated sludge flocs)
- Operate at high MLSS concentrations (e.g., 8,000 mg/L or higher)
- No mixers required
- Possible to retrofit existing tanks for Nereda if tanks are deep enough (greater than 15 feet)
- Granule structure is resistant to toxicity

### Known Issues/Risks:

- Equalization tank needed upstream for plants with high wet weather flow peaking factors, or could use Nereda to treat a fixed base loading
- SBR operation requires multiple trains and can be more operationally complex than other processes for cycle timing.
- Intermittent wasting needs to be accounted for in WAS thickening system design
- Granular sludge seed used for startup
- Startup requires approximately 4–6 months to form mature granules

- Granule formation relies on biological phosphorus removal to select for PAOs, so sufficient readily biodegradable carbon is needed in the influent wastewater

**Applicable KC WTD Plants:**  West Point  South Plant  Brightwater

## Modified Ludzack-Ettinger (MLE) Configuration

**Classification:** Mainstream

**Process Description:**

The MLE process is an activated sludge system with an unaerated (anoxic) zone followed by an aerated zone, with an internal mixed liquor recycle (IMLR) from the aerated zone to the anoxic zone. Ammonia in the primary effluent passes through the anoxic zone and is oxidized to nitrate in the aerated zone via the nitrification process. The resulting nitrate is denitrified (converted to nitrogen gas) in the anoxic zone by returning a portion of the nitrate-rich mixed liquor from the aerated zone to the anoxic zone through the IMLR. Denitrification uses the carbon available in the wastewater, or an external carbon source (e.g., methanol) can also be added to increase nitrogen removal if the wastewater is carbon limited. Secondary clarifiers separate the biological solids from the clarified effluent. The settled biological solids are returned to the anoxic zone via the RAS.

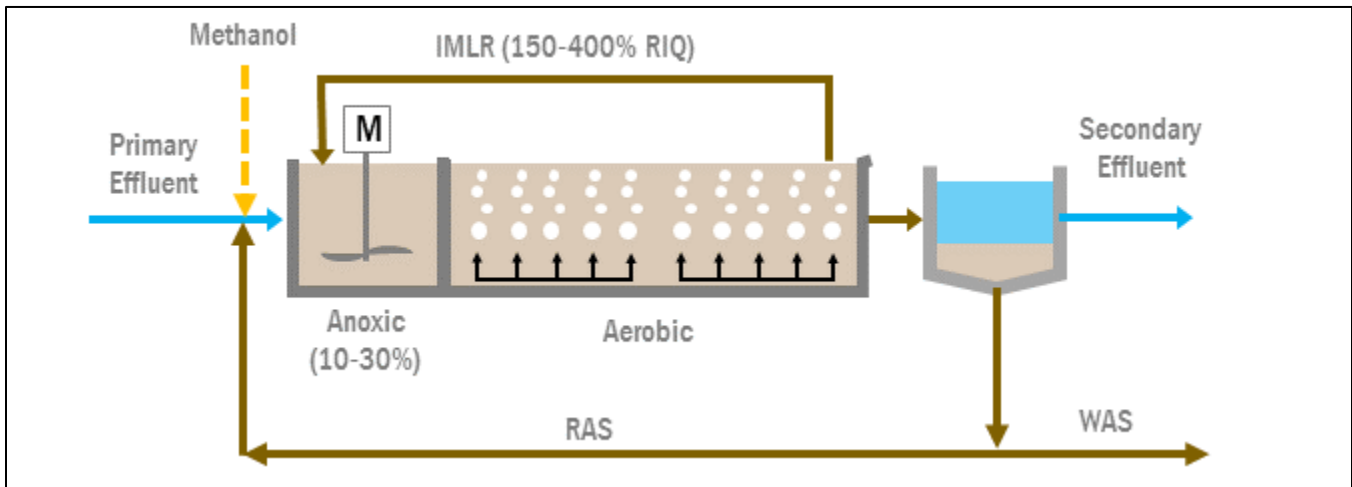

Process flow diagram

**Status:** Established

Number of Installations		
Full scale	Pilot scale	Lab scale
> 50	N/A	N/A

**Reference Installations (Up to Five):**

1. Central Kitsap Treatment Plant, Kitsap County, WA (8.2 mgd peak month design flow) – 4 stage Bardenpho is intended to be primary mode of operation, but can also operate in other modes, including MLE.
2. Chambers Creek WWTP, Pierce County, WA (45 mgd peak month design flow) – 4 Stage Bardenpho is intended to be primary mode of operation when N removal is required, but can also operate in other modes, including MLE.
3. Back River WWTP, Baltimore, MD (180 mgd)
4. Cox Creek, MD (15 mgd)
5. Seneca, MD (20 mgd)

**Estimated Time to Full Scale:** N/A

## Key Considerations:

### Practicality of Scaling Technology to Large WWTP: High

Potential Impacts of Technology					
Parameter	Low	Medium	High	Season	Notes
Effluent N concentration benefit		✓		Year-round	Difficult to meet low N limits with only single anoxic zone
Footprint impact			✓		Large footprint required for conventional process, but less than 4SMB
Impacts to other plant processes	✓				
Truck traffic impact		✓			
<b>Sustainability</b>					
<i>Energy use</i>		✓			Aeration for nitrification and IMLR pumping
<i>GHG emissions</i>		✓			High electricity consumption for aeration, but expect relatively low N <sub>2</sub> O emissions and chemical demands (depending on requirements for supplemental carbon).
<i>Resource recovery benefit</i>		✓			Potential to meet TN limits (down to 10 mg/L TN) for reclaimed water production, though likely difficult with just MLE configuration
Relative capital cost		✓			Large footprint but no proprietary equipment/processes
Relative O&M cost	✓				Depends on requirements for supplemental carbon
Operational complexity	✓				

#### Other Notable Characteristics:

- Simple, reliable process
- Can be paired with intensification and/or sidestream treatment processes to reduce footprint
- Aeration basins can be configured with swing zones to allow flexibility to change anoxic zone size or operate a second anoxic zone depending on N removal requirements

#### Known Issues/Risks:

- Single anoxic zone limits overall N removal capability
- Potential for biological foaming at longer SRTs required for N removal (can be mitigated with foam control methods)

**Applicable KC WTD Plants:**  West Point  South Plant  Brightwater

Note: Brightwater is currently operated in an MLE/MBR configuration, but with RAS return to the first aerobic zone.



# Simultaneous Nitrification-Denitrification (SND) / Nitrite Shunt

**Classification:** Mainstream

**Process Description:**

The basis for the SND process is that nitrification and denitrification occur concurrently in the same aerobic reactor operated at low bulk dissolved oxygen (DO) concentrations, with several reactions taking place simultaneously within a biological floc:

- Outer layer – Diffusion of ammonia and organics into the floc from the bulk liquid phase.
- Aerobic floc zone – Carbonaceous BOD oxidation and nitrification.
- Anoxic floc zone – Denitrification in the innermost part of a floc where the DO concentration is minimal.

SND may also occur via a nitrite shunt/shortcut SND process, where ammonia is oxidized to nitrite and nitrite is denitrified to nitrogen gas. In this case, nitrite, instead of nitrate, is the intermediate end product. Relative to conventional nitrification-denitrification, the nitrite shunt pathway provides a 25 percent reduction in oxygen demand, 40 percent reduction in carbon demand, and 40 percent reduction in biomass production.

SND can be implemented with any other mainstream N-removal process as an alternative operating strategy to minimize aeration and carbon demands. SND requires precise control of the DO concentrations in different parts of the aeration basins. Typically, DO concentration setpoints of approximately 0.2 to 0.5 mg/L are used. Elevated DO concentrations may be required in the final aerobic zones to meet low effluent ammonia limits. Advanced aeration controls, such as ammonia-based aeration control (ABAC), are often recommended to maximize performance and to provide process stability.

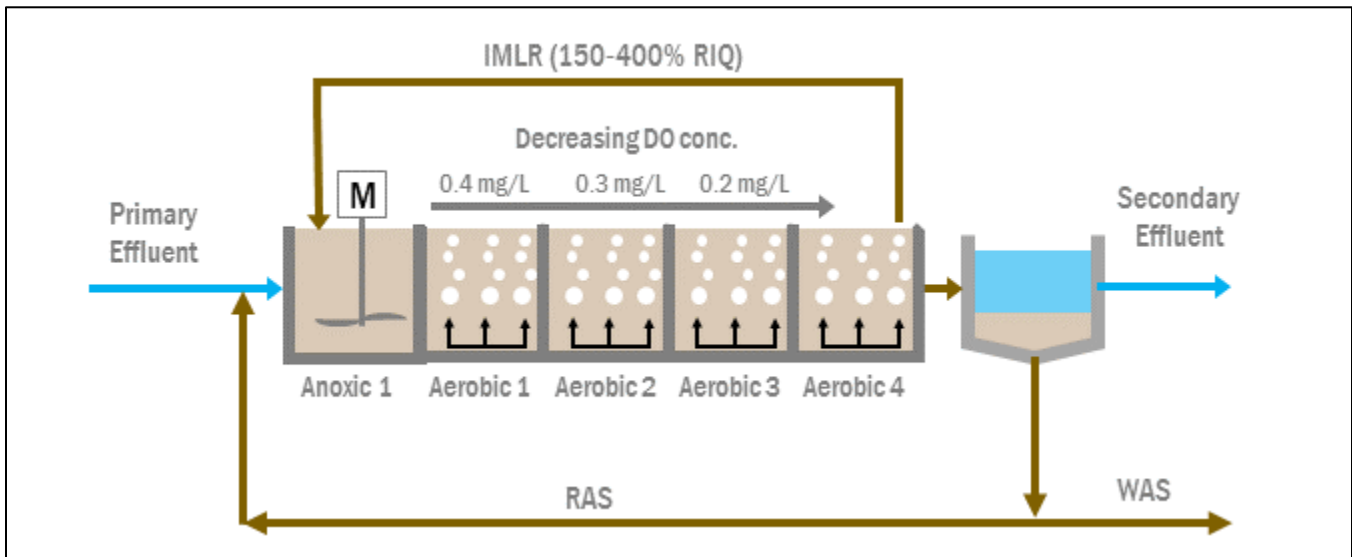

Process flow diagram (example of MLE process operated for SND)

**Status:** Established

Number of Installations		
Full scale	Pilot scale	Lab scale
> 5	N/A	N/A

**Reference Installations (Up to Five):**

1. Southwest Water Reclamation Facility, St. Petersburg, FL (20 MGD)
2. Iron Bridge WWTP, Orlando, FL (40 mgd)
3. Southwest WWTP, Orange County, FL (10 mgd)
4. Pueblo, CO (15 mgd) – under construction

**Estimated Time to Full Scale:** N/A

## Key Considerations:

### Practicality of Scaling Technology to Large WWTP: High

Potential Impacts of Technology					
Parameter	Low	Medium	High	Season	Notes
Effluent N concentration benefit			✓	Year-round	Capable of meeting low N limits
Footprint impact			✓		Likely increased footprint compared to typical operating strategies for MLE and 4SMB configurations
Impacts to other plant processes	✓				
Truck traffic impact		✓			
Sustainability					
Energy use	✓				Can substantially reduce process aeration demands
GHG emissions			✓		Higher N <sub>2</sub> O production potential because of low DO operation, but lower overall electricity requirements and chemical demands relative to traditional aeration operating strategies.
Resource recovery benefit					No negative impact on resource recovery options. Provides N removal for reclaimed water production (to TN < 10 mg/L), but coagulation/filtration still needed.
Relative capital cost		✓			
Relative O&M cost	✓				Reduces process aeration and carbon demands
Operational complexity		✓			

#### Other Notable Characteristics:

- Can be paired with intensification and/or sidestream treatment processes to reduce footprint

#### Known Issues/Risks:

- Requires specialized aeration control strategies (e.g., ABAC) and tight DO control (+/- 0.05 mg/L)
- Heavy reliance on process instrumentation/sensors
- Potential for filamentous bulking with low DO conditions if DO not controlled tightly
- May recommend SND with cyclones for settling improvements

#### Applicable KC WTD Plants: West Point South Plant Brightwater

Note: SND was one of the preferred alternatives selected for further evaluation at Brightwater as part of the aeration basins optimization project, where SND modeling estimated up to 50 percent reduction in current caustic and aeration demands.

# Anammox

**Classification:** Sidestream

**Process Description:**

Anammox-based sidestream treatment processes can be used to remove nitrogen from dewatering recycle streams via a shortcut process that reduces overall aeration and alkalinity requirements, while also eliminating carbon demands for denitrification. The shortcut involves allowing only partial nitrification under aerobic conditions, where approximately half of the ammonium is converted to nitrite, followed by anaerobic conversion of ammonium to nitrogen gas using Anammox bacteria. In contrast to a typical denitrification process, where an external carbon source is required to convert nitrate/nitrite to nitrogen gas, the Anammox bacteria can remove ammonia under anaerobic conditions using nitrite as the electron acceptor and carbon dioxide as the carbon source. There are several commercially available processes that utilize Anammox bacteria for sidestream treatment (e.g., DEMON® [continuous or SBR configuration], ANITA™ Mox, AnammoPAQ™, etc.).

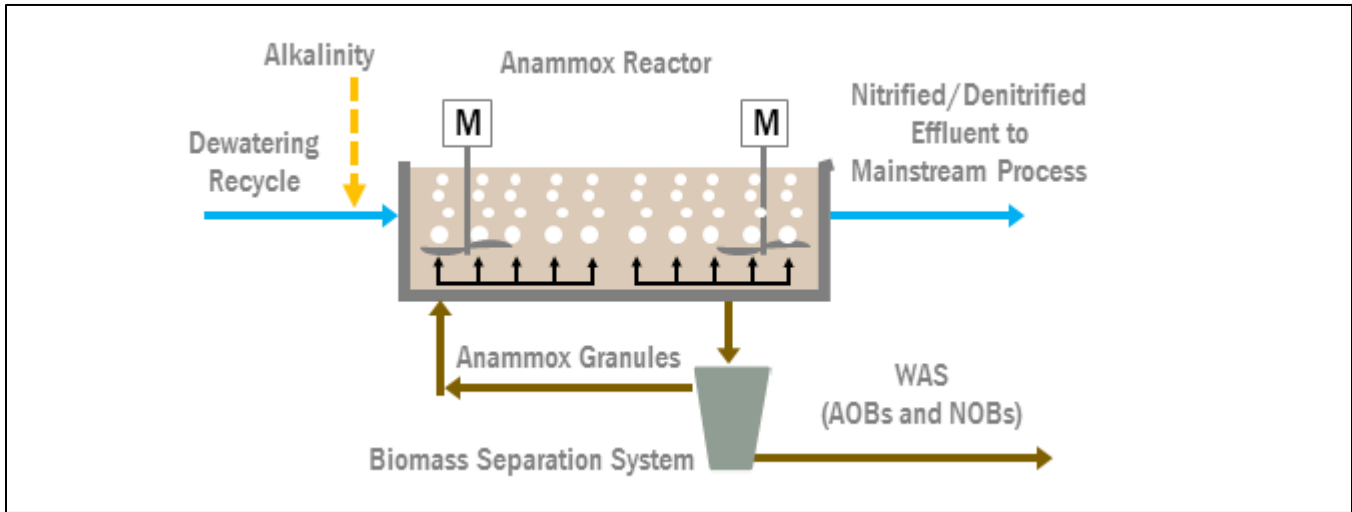

**Process flow diagram (example for continuous version of DEMON)**

**Status:** Established

Number of Installations		
Full scale	Pilot scale	Lab scale
> 50	N/A	N/A

**Reference Installations (Up to Five):**

1. DEMON: Chambers Creek WWTP, Pierce County, WA (45 mgd peak month design flow)
2. DEMON: York River WWTP, Hampton Roads Sanitation District, Seaford, VA (13.7 mgd)
3. DEMON: AlexRenew WWTP, Alexandria, VA (54 mgd average)
4. ANITA Mox: James River WWTP, Newport News, VA (20 mgd)
5. ANITA Mox: South Durham Water Reclamation Facility, Durham, NC (20 mgd)

**Estimated Time to Full Scale:** N/A

## Key Considerations:

### Practicality of Scaling Technology to Large WWTP: High

Potential Impacts of Technology					
Parameter	Low	Medium	High	Season	Notes
Effluent N concentration benefit	✓			Year-round	
Footprint impact	✓				Potential to reduce required size of mainstream basins
Impacts to other plant processes	✓				Potential to reduce overall solids production
Truck traffic impact		✓			
Sustainability					
Energy use	✓				Aeration demand reductions
GHG emissions		✓			Reduced aeration and supplemental carbon requirements for main stream processes. Exact impact of greenhouse gas emissions is unknown for Anammox, but some re-search suggests minimal N <sub>2</sub> O emissions.
Resource recovery benefit					No negative impact on resource recovery options
Relative capital cost		✓			Potential to reduce size of mainstream basins but also high capital cost of proprietary Anammox processes
Relative O&M cost	✓				Aeration and carbon demand reductions
Operational complexity		✓			

#### Other Notable Characteristics:

- Anammox seed sludge required for system startup
- Provide high N removal efficiency for dewatering recycle (typically greater than 75 percent ammonia removal and greater than 70 percent TIN removal)
- Supplied as vendor-package, proprietary systems
- Vendors have various methods of retaining Anammox bacteria/granules in the system (e.g., micro-screens, cyclones, sieves/screens for plastic media, proprietary separators, etc.)
- Requires heavy use of instrumentation/sensors
- Some form of sidestream anammox is needed for mainstream anammox via bioaugmentation
- Equalization recommended.

#### Known Issues/Risks:

- Dewatering recycle may require pretreatment if organics/TSS concentrations are above vendor limitations (typically 1,000 mg/L)
- May require some supplemental alkalinity addition
- Important to keep temperature of dewatering recycle as high as possible for feed to the Anammox process (limit temperature loss through dewatering and upstream tanks)

**Applicable KC WTD Plants:**  West Point  South Plant  Brightwater

# Bioaugmentation

**Classification:** Sidestream

**Process Description:**

Bioaugmentation processes involve aerating ammonia-rich dewatering recycle streams with RAS in a side-stream aeration basin to achieve nitrification. The ammonia in the recycle stream is converted into nitrate and returned to the main biological process basins. Nitrifying the recycle streams in a separate tank creates a highly specialized and efficient population of nitrifying organisms. These bacteria seed the main biological treatment process and can enhance nitrification processes throughout the system. RAS provides a source of alkalinity for the bioaugmentation process.

Various bioaugmentation configurations are available, including bioaugmentation reaeration (BAR), bioaugmentation batch enhanced (BABE), and inexpensive nitrification (inNitri). BAR is the simplest configuration and uses a complete-mix aerobic reactor. BABE uses a sequencing batch reactor configuration that cycles through anoxic and aerobic phases, returning a denitrified effluent to the main process stream. The inNitri process is like BAR but adds a secondary clarification step to allow independent SRT control.

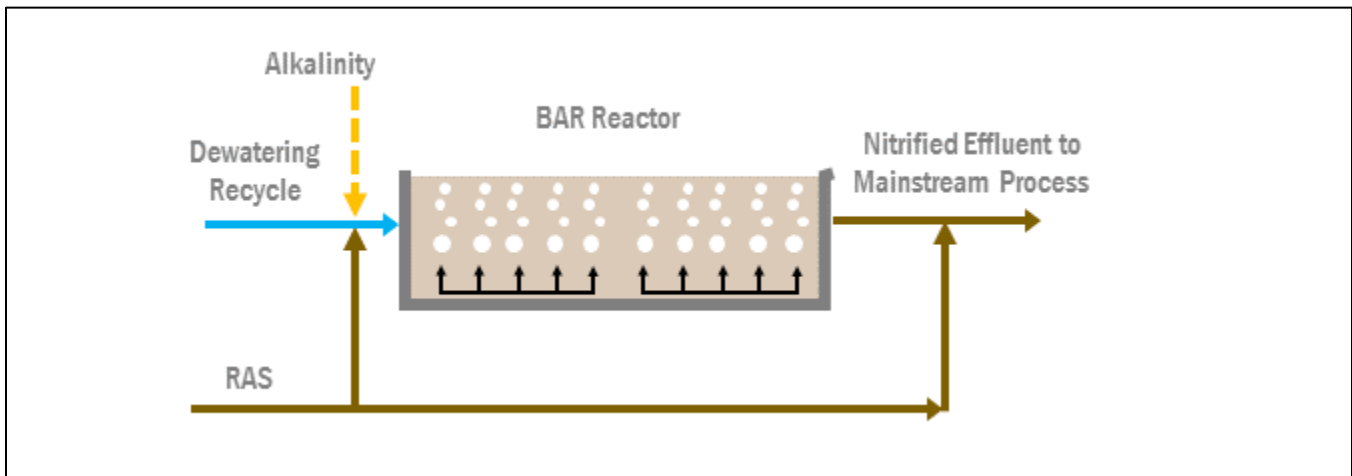

Process flow diagram (BAR example)

**Status:** Established

Number of Installations		
Full scale	Pilot scale	Lab scale
> 30	N/A	N/A

**Reference Installations (Up to Five):**

1. BAR: Appleton WWTP, Appleton, WI (15.5 mgd)
2. inNitri: Richmond, VA (80 mgd)
3. BABE: Groningen, Netherlands
4. BAR: Theresa Street WWTP, Lincoln, NE (27 mgd)
5. BAR: Blue Lake WWTP, Shakopee, MN (50 mgd)

**Estimated Time to Full Scale:** N/A

## Key Considerations:

### Practicality of Scaling Technology to Large WWTP: High

Potential Impacts of Technology					
Parameter	Low	Medium	High	Season	Notes
Effluent N concentration benefit	✓			Year-round	Depends on selected bioaugmentation configuration
Footprint impact		✓			Potential to reduce required size of mainstream basins, but need tankage for bioaugmentation
Impacts to other plant processes	✓				Requires modification to RAS routing
Truck traffic impact		✓			
Sustainability					
Energy use		✓			May increase overall aeration demands
GHG emissions		✓			Compared to Anammox, higher electricity consumption for aeration. Supplemental carbon is required for denitrification and supplemental alkalinity may also be required. N <sub>2</sub> O emissions likely depend on the selected bioaugmentation configuration, but BAR with fully aerobic reactor likely to have low N <sub>2</sub> O emissions.
Resource recovery benefit					No negative impact on resource recovery options
Relative capital cost	✓				Depends on selected bioaugmentation configuration
Relative O&M cost		✓			May increase overall aeration and carbon demands
Operational complexity	✓				

#### Other Notable Characteristics:

- Relatively simple sidestream treatment process that can reduce the size of the mainstream process basins
- Does not require pretreatment of the dewatering recycle stream (no influent TSS limitations)
- Non-proprietary configurations available

#### Known Issues/Risks:

- May require alkalinity addition to prevent pH limitations
- Consumes any readily biodegradable carbon in the dewatering recycle (could increase carbon demands for the main N removal process)

**Applicable KC WTD Plants:**  West Point  South Plant  Brightwater

# Post Aerobic Digestion (PAD)

**Classification:** Sidestream

**Process Description:**

PAD is an aerobic digestion process that follows an anaerobic digestion process. The PAD process is typically operated with an SRT/HRT of 5–10 days at approximately 35 °C. The PAD reactor is typically self-heating because the aerobic digestion reactions release heat, but this can also require provisions for cooling. PAD uses intermittent aeration to create cyclical aerobic/anoxic conditions to drive nitrification and denitrification, providing approximately 80–95 percent ammonia removal and up to 90 percent total inorganic nitrogen (TIN) removal from the digested sludge without supplemental alkalinity or carbon addition. The PAD process also provides an additional 10–40 percent volatile solids reduction compared to mesophilic anaerobic digestion alone. The technology was developed by Virginia Tech and DC Water and licensed to Ovivo in 2016, marketed as DigestivorePAD™.

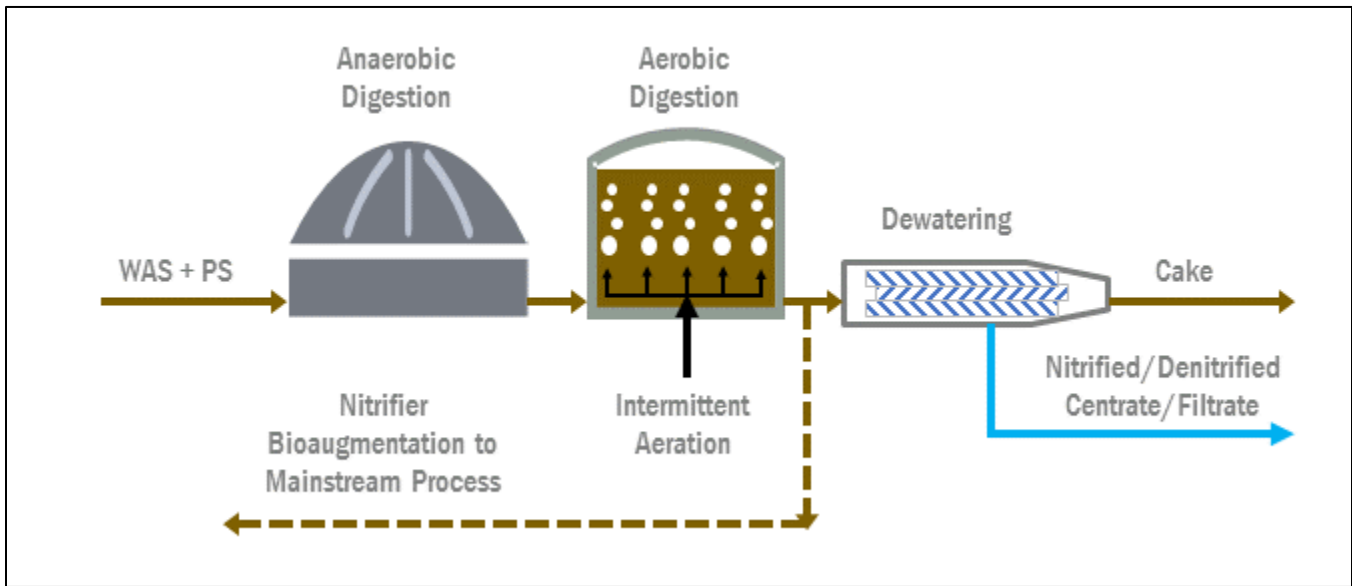

Process flow diagram

**Status:** Innovative

Number of Installations		
Full scale	Pilot scale	Lab scale
3	N/A	N/A

**Reference Installations (Up to Five):**

1. Spokane County Regional WRF, Spokane, WA (8 mgd) – first full-scale PAD process in North America
2. Northern Treatment Plant, Denver Metro WRD, Brighton, CO (24 mgd)
3. Boulder 75<sup>th</sup> Street WWTP, Boulder, CO (25 mgd)
4. Meridian WWRF, Meridian ID (lab-scale study of PAD with bioaugmentation)

**Estimated Time to Full Scale:** N/A

## Key Considerations:

### Practicality of Scaling Technology to Large WWTP: High

Potential Impacts of Technology					
Parameter	Low	Medium	High	Season	Notes
Effluent N concentration benefit	✓			Year-round	
Footprint impact			✓		Potential to reduce footprint of main liquid stream process but increased digestion tankage required for PAD
Impacts to other plant processes	✓				Potential to improve digested sludge dewaterability and reduce polymer use
Truck traffic impact	✓				Potential to reduce biosolids hauling
Sustainability					
Energy use			✓		High energy demand for PAD aeration
GHG emissions		✓			High electricity requirements for aeration but typically no supplemental chemicals required. Potential N <sub>2</sub> O emissions would need to be confirmed but would likely depend on the operating strategy for intermittent aeration and if nitrite accumulation occurs.
Resource recovery benefit					No negative impact on resource recovery options (unless future struvite recovery were considered)
Relative capital cost			✓		High capital cost for PAD tankage
Relative O&M cost		✓			High energy for aeration but may be offset by reduced biosolids hauling (greater VS destruction and potentially increased cake dryness) and supplemental alkalinity/carbon savings
Operational complexity		✓			

#### Other Notable Characteristics:

- Nitrification without supplemental alkalinity
- Denitrification without supplemental carbon
- Reduced biosolids odor
- Struvite stabilization in the digested sludge
- Potential for bioaugmentation of PAD nitrifiers to the main liquid stream process, but PAD nitrifiers would be adapted to warmer conditions of PAD reactor (35 °C), which could reduce benefit

#### Known Issues/Risks:

- Cooling may be required for PAD reactor during summer
- Foaming in PAD reactor

**Applicable KC WTD Plants:**  West Point  South Plant  Brightwater



# Physical/Chemical Nutrient Recovery Processes

**Classification:** Sidestream

## **Process Description:**

Conventional ammonia stripping is an established technology that uses a strong base to increase pH to convert ammonium ions to ammonia gas in solution, followed by a stripping process to release the ammonia gas to atmosphere. In contrast to conventional ammonia stripping, newer technologies are emerging that allow reduced chemical inputs and recovery of the stripped ammonia as a fertilizer product, such as Anaergia's Ammonia Recovery Process (AMR). AMR does not use a strong base to raise the pH, but rather uses CO<sub>2</sub> stripping facilitated by turbulence. The stripping reactor is heated to increase the ammonia stripping rate and diffused air is used for mixing/stripping. The stripped ammonia gas is condensed and recovered as ammonium sulfate fertilizer through addition of sulfuric acid in a packed-bed scrubber. AMR Effluent

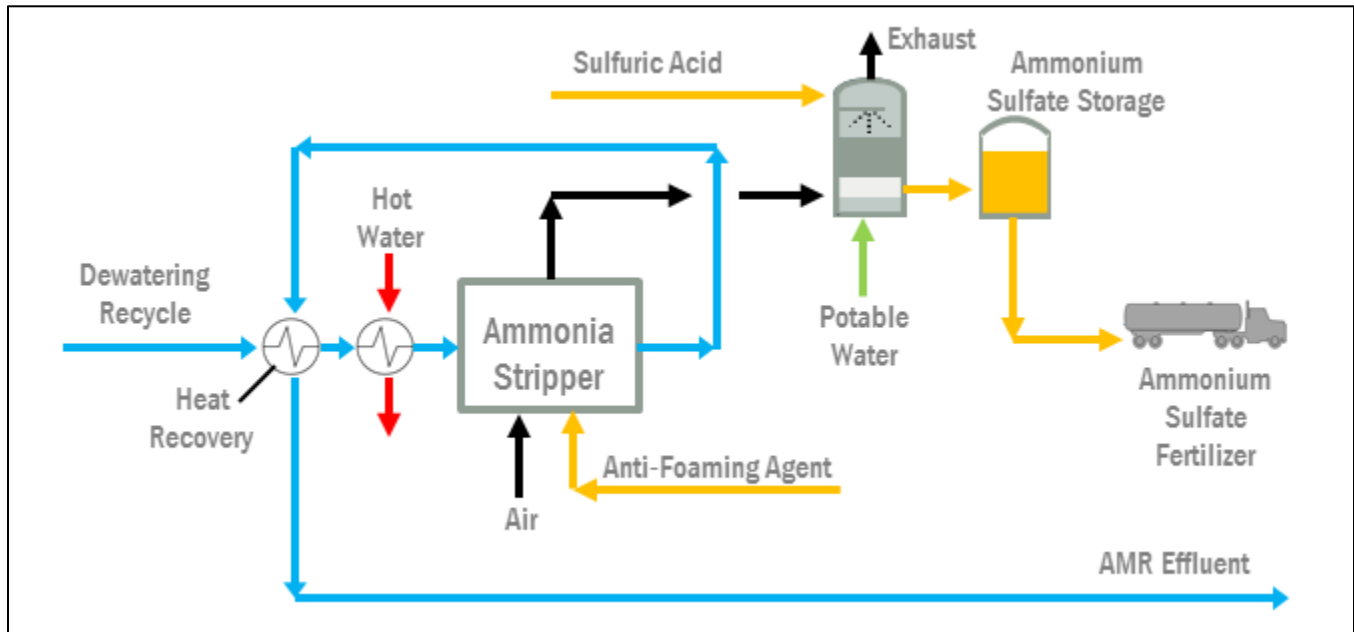

**Process flow diagram (Anaergia AMR process)**

Struvite crystallization is another sidestream treatment technology that can be used to remove ammonium from dewatering recycle streams (or digested sludge), but it is primarily applied at biological phosphorus removal (bio-P) activated sludge plants where higher concentrations of phosphorus are released during anaerobic digestion. Struvite is a combination of magnesium, ammonium, and phosphate ( $MgNH_4PO_4 \cdot 6H_2O$ ) that can be marketed as a slow-release fertilizer product. Struvite crystallization technologies can typically remove up to 80–95 percent of phosphorus from dewatering recycle streams (or digested sludge), but overall N removal is limited because struvite is only 5.7 percent N (12.6 percent phosphorus) and dewatering recycle streams have more N than phosphorus, particularly for non-bio-P plants. N removal as struvite is typically limited to approximately 15–25 percent of the total dewatering recycle N load for bio-P plants, and will likely be closer to 5–10 percent removal for non-bio-P plants. There are many commercially available processes that use struvite crystallization for sidestream phosphorus removal (e.g., Ostara-Pearl®, AirPrex®, Multi-form™ Harvest, NuReSys, etc.).

## Ostara's Pearl® Process

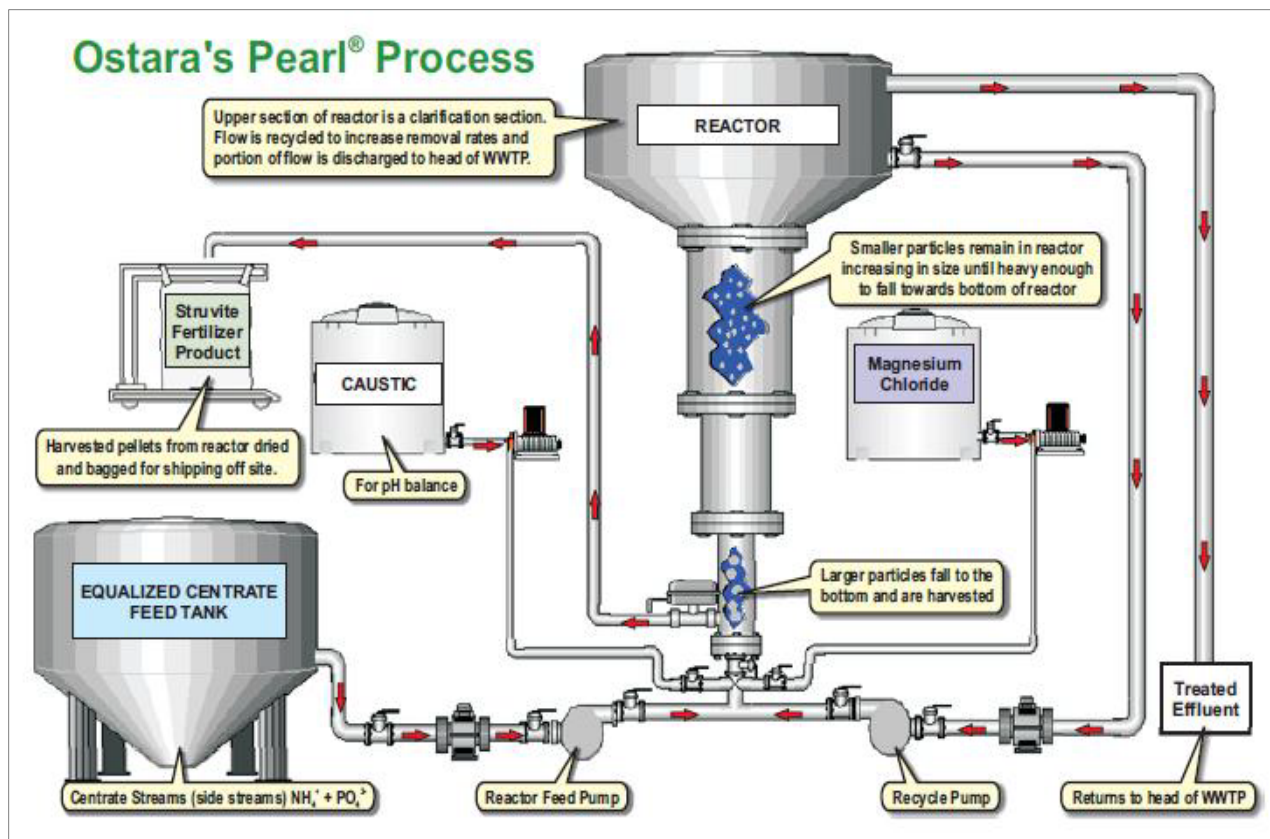

Process flow diagram (Ostara-Pearl process)

*Courtesy of Ostara.*

**Status:** Embryonic (ammonia recovery), Established (struvite crystallization)

Technology	Number of Installations		
	Full scale	Pilot scale	Lab scale
Ammonia recovery	0	< 5	N/A
Struvite crystallization	> 50	N/A	N/A

### Reference Installations (Up to Five):

1. Ostara-Pearl: Stickney Water Reclamation Plant, Chicago, IL (1,400 mgd)
2. Ostara-Pearl + WASSTRIP™: Durham AWWTF, Clean Water Services, Tigard, OR (25 mgd)
3. Multiform Harvest: West Boise Wastewater Treatment Facility, Boise, ID (24 mgd)
4. AirPrex: Little Patuxent Water Reclamation Plant, Savage, MD (29 mgd)
5. AirPrex: Liverpool WWTP, Medina, OH (15 mgd)

**Estimated Time to Full Scale:** < 5 years (ammonia recovery)

Note: Delta Diablo is currently pursuing installation of a full-scale Anaergia AMR process at the district's municipal WWTP in Antioch, CA as part of the East County Bioenergy Project.

## Key Considerations:

**Practicality of Scaling Technology to Large WWTP:** Low (ammonia recovery), High (struvite crystallization)

Potential Impacts of Technology					
Parameter	Low	Medium	High	Season	Notes
Effluent N concentration benefit	✓			Year-round	AMR can remove majority of ammonia from dewatering recycle, but struvite crystallization will have minor impact on N removal.
Footprint impact		✓			AMR has potential to reduce required size of mainstream basins, but likely adds large footprint requirement
Impacts to other plant processes		✓			AMR requires source of plant hot water for heating
Truck traffic impact			✓		
Sustainability					
Energy use			✓		AMR would have high heat/energy inputs
GHG emissions			✓		High energy and chemical demands for ammonia recovery processes, but minimal N <sub>2</sub> O emissions potential.
Resource recovery benefit			✓		Recovery of N and/or P as fertilizer products, but struvite formation potential will be limited without bio-P
Relative capital cost			✓		High capital cost for proprietary equipment/processes
Relative O&M cost			✓		AMR: high energy demand and requires sulfuric acid to form ammonium sulfate, but potential to sell ammonium sulfate fertilizer
Operational complexity			✓		

### Other Notable Characteristics:

- AMR operates at high temperatures and requires heating (60–65 °C for stripping reactor)
- AMR expected to provide approximately 85 percent ammonia removal
- AMR has demand for potable water for acid scrubber
- Struvite crystallization technologies require magnesium addition (usually magnesium chloride)
- Some struvite crystallization processes can be applied on digested sludge (e.g., AirPrex)

### Known Issues/Risks:

- AMR requires concentrated sulfuric acid (safety hazard)
- Need reliable market for ammonium sulfate fertilizer and price susceptible to market conditions
- Some struvite crystallization processes require caustic addition (safety hazard)
- Struvite crystallization alone will have small impact on overall ammonium removal from dewatering recycle for non-bio-P plants (would need to be coupled with downstream sidestream N removal process, like Anammox or AMR)

**Applicable KC WTD Plants:**  West Point  South Plant  Brightwater

# Shortcut N Removal

**Classification:** Sidestream

**Process Description:**

Shortcut N removal processes for sidestream treatment convert ammonia to nitrite in an aerobic reactor that is controlled at conditions to promote growth of ammonia oxidizing bacteria (AOB) while inhibiting growth of nitrite oxidizing bacteria (NOB). AOB oxidize ammonia to nitrite (nitritation), which can then be reduced to nitrogen gas by heterotrophic bacteria (denitritation). The denitritation process requires a carbon source, but the overall process reduces oxygen and carbon demands compared to conventional nitrification/denitrification.

The SHARON® process (Single reactor system for High-activity Ammonia Removal Over Nitrite) is the most common technology for shortcut N removal for sidestream treatment. SHARON uses either a single- or dual-stage complete-mix reactor (without biomass retention) maintained at 35 °C and requires tight control of temperature, pH, DO, ammonia, nitrite, and nitrate levels. The high temperature favors the growth of AOB over NOB.

The CANDO process (Coupled Aerobic-anoxic Nitrous Decomposition Operation) is another variant that is still in the research stages. Like SHARON, the first step in the CANDO process is aerobic nitrite production, but CANDO adds two subsequent steps for biological conversion of nitrite to nitrous oxide (N<sub>2</sub>O) and decomposition or combustion of N<sub>2</sub>O for energy production. For example, N<sub>2</sub>O may be combusted with methane to produce energy and convert N<sub>2</sub>O to nitrogen gas.

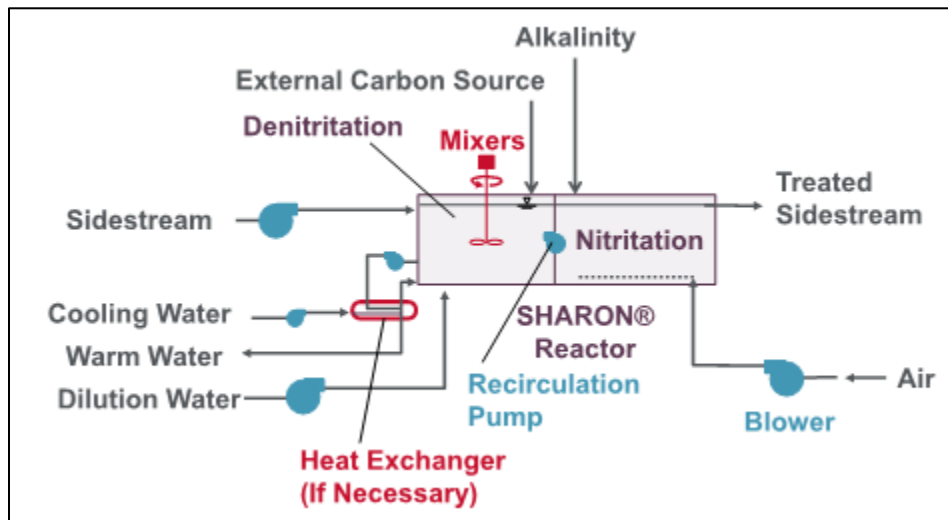

**Process flow diagram (SHARON example)**

*Referenced from EPA Sidestream Nutrient Removal Study (US EPA, 2017)*

**Status:** Established (SHARON), Embryonic (CANDO)

Technology	Number of Installations		
	Full scale	Pilot scale	Lab scale
SHARON	> 5	N/A	N/A
CANDO	N/A	1	Various

**Reference Installations (Up to Five):**

1. SHARON: Wards Island WWTP, Manhattan, NY (275 mgd) – in process of being upgraded following a pilot demonstration of an anammox MBBR system that was similar to ANITA Mox
2. SHARON: Geneva, Switzerland
3. SHARON: Whitlingham, Norwich, U.K.
4. Various SHARON installations in the Netherlands
5. CANDO: Delta Diablo WWTP, Antioch, CA (pilot)

**Estimated Time to Full Scale:** Practicality of CANDO at full scale yet to be determined

**Key Considerations:**

**Practicality of Scaling Technology to Large WWTP:** High

Potential Impacts of Technology					
Parameter	Low	Medium	High	Season	Notes
Effluent N concentration benefit	✓			Year-round	Requires coupling with anoxic step for denitrification
Footprint impact		✓			Potential to reduce required size of mainstream basins
Impacts to other plant processes	✓				Potential to reduce overall solids production
Truck traffic impact		✓			
Sustainability					
Energy use		✓			Reduced aeration requirements
GHG emissions			✓		Compared to Anammox, higher electricity consumption for aeration and supplemental carbon is required for denitrification. Shortcut N processes also have higher N <sub>2</sub> O production potential (nitrite accumulation) - CANDO attempts to produce N <sub>2</sub> O and combust it.
Resource recovery benefit					No negative impact on resource recovery options. Potential for energy recovery with CANDO.
Relative capital cost		✓			
Relative O&M cost		✓			Aeration and carbon savings, but not as beneficial compared to Anammox
Operational complexity			✓		

**Other Notable Characteristics:**

- Nitritation requires approximately 25 percent less oxygen than complete nitrification
- Denitrification requires approximately 40 percent less carbon than denitrification
- Reduced sludge production of approximately 30–40 percent compared to conventional nitrification/denitrification process
- Not impacted by high TSS in the dewatering recycle stream
- CANDO technology requires a cogeneration facility to recover the energy from the biogas
- CANDO typically uses acetate addition to select for polyhydroxybutyrate (PHB) accumulating organisms

**Known Issues/Risks:**

- Anammox is usually favored over SHARON for sidestream treatment because Anammox does not require a carbon source for denitrification. The SHARON process may also be operated in a two-stage configuration with a SHARON reactor followed by an Anammox reactor, which is a configuration that was offered by Paques as the SHARON-ANAMMOX process.

**Applicable KC WTD Plants:**  West Point  South Plant  Brightwater

# Tertiary Algae Treatment

**Classification:** Tertiary

**Process Description:**

Tertiary algae treatment removes nitrogen and phosphorus by mixing secondary effluent with algae to remove nutrients and create an algae product that can be harvested for biopolymer production. The algae/effluent mixture is mixed with carbon dioxide and passes through a series of clear glass tubes located in greenhouses (to maintain temperature), where it is exposed to light to stimulate photosynthesis. The photosynthetic reactions allow for additional algae growth and uptake of nutrients to support that growth. The grown algae are then separated from the effluent using ultrafiltration membranes, where it is then recycled to the process or wasted to processing. The separated effluent has gone through filtration and may be of reuse quality, depending on reuse nutrient requirements.

There is currently one manufacturer of this technology, CLEARAS Water Recovery, and the process is known as the CLEARAS ABNR system. This company prefers to have a contract to purchase all waste algae for processing and reuse.

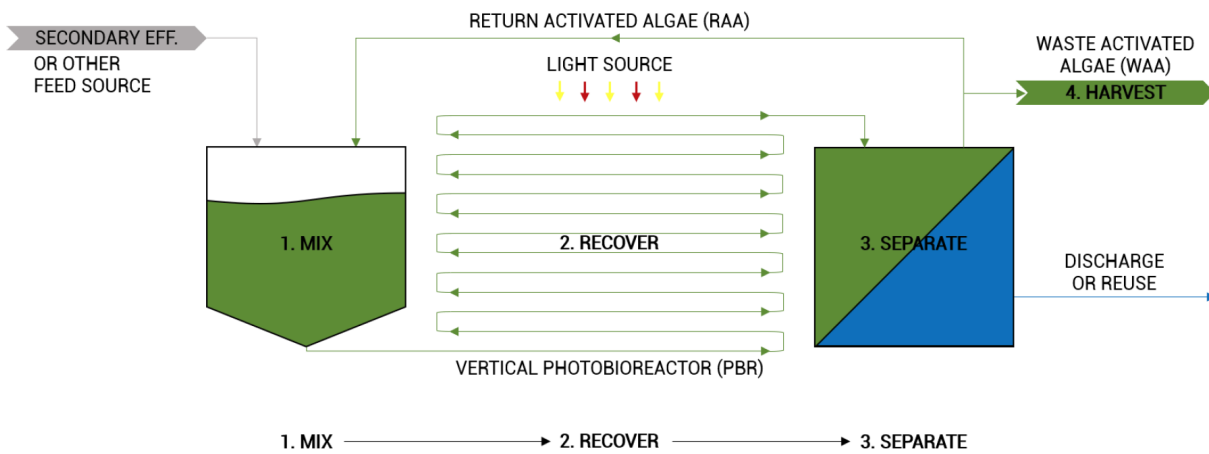

**Process flow diagram from CLEARAS Water Recovery**

**Status:** Innovative

Number of Installations		
Full scale	Pilot scale	Lab scale
1	<10	N/A

**Reference Installations (Up to Five):**

1. South Davis Sewer District, Utah (4 mgd) – currently in construction
2. Inland Empire Paper, Spokane, WA (0.04 mgd – industrial facility)
3. 16,000 gpd pilot system operated in at least 4 municipal treatment systems

**Estimated Time to Full Scale:** N/A

## Key Considerations:

### Practicality of Scaling Technology to Large WWTP: Low

Potential Impacts of Technology					
Parameter	Low	Medium	High	Season	Notes
Effluent N concentration benefit			✓	Year-round	Some nitrogen removal occurs, but often is phosphorus limited. Phosphorus addition may be needed to get to lower levels.
Footprint impact			✓		Large footprint requirements for treatment tubes.
Impacts to other plant processes	✓				No impact to other plant processes.
Truck traffic impact		✓			
Sustainability					
Energy use		✓			Power for lamps to supply light for daily use. LED lamps used to keep power costs low. Ultrafiltration
GHG emissions		✓			Likely high electricity consumption for operation of ultrafiltration membranes and lights, with chemicals required for carbon dioxide addition. However, algae capture carbon dioxide and release oxygen.
Resource recovery benefit			✓		Recover algae for processing as biopolymer or other resource use.
Relative capital cost			✓		High capital cost for system.
Relative O&M cost		✓			Light and carbon dioxide addition needed. No aeration required. Ultrafiltration membranes require replacement and maintenance.
Operational complexity		✓			

#### Other Notable Characteristics:

- Requires ultrafiltration for algae separation from effluent. Ultrafiltration membranes must be sized for full flow and may take significant space.

#### Known Issues/Risks:

- Single glass tube supplier with long lead-times for manufacture. Some question on ability to scale to larger size facilities due to this limitation.
- Phosphorus addition may be required for full denitrification.

**Applicable KC WTD Plants:**  West Point  South Plant  Brightwater

# Tertiary Anammox Polishing Process

**Classification:** Tertiary

**Process Description:**

Anammox-based treatment processes can be used to remove nitrogen from secondary effluent via a shortcut process that reduces overall aeration and alkalinity requirements, while also eliminating carbon demands for denitrification. The shortcut involves allowing only partial nitrification under aerobic conditions, where approximately half of the ammonium is converted to nitrite, followed by anaerobic conversion of ammonium to nitrogen gas using Anammox bacteria. In contrast to a typical denitrification process, where an external carbon source is required to convert nitrate/nitrite to nitrogen gas, the Anammox bacteria can remove ammonia under anaerobic conditions using nitrite as the electron acceptor and carbon dioxide as the carbon source. There are several commercially available processes that utilize Anammox bacteria for side-stream treatment, but to date none that are available for tertiary treatment. For tertiary anammox to work, secondary effluent from the mainstream process must have residual ammonia and nitrite for the anammox bacteria to convert ammonia and nitrite to nitrogen gas.

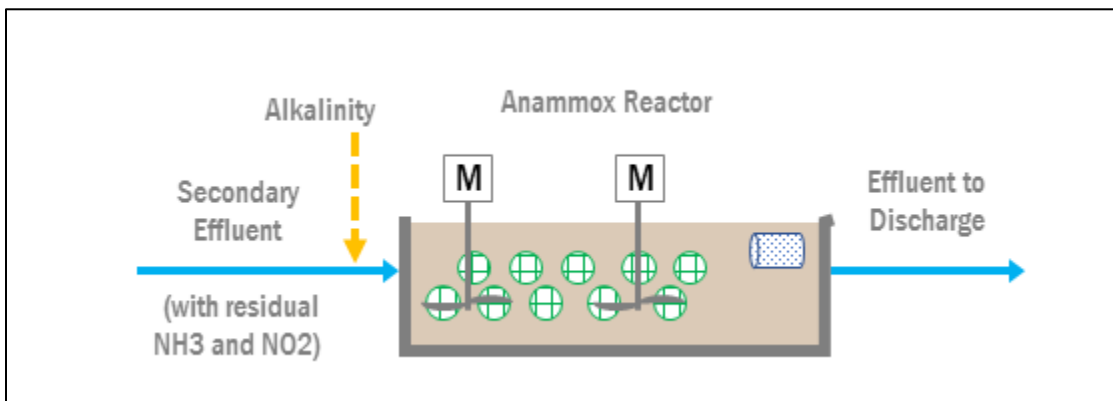

**Process flow diagram (example as tertiary anammox MBBR)**

**Status:** Innovative

Number of Installations		
Full scale	Pilot scale	Lab scale
1	<5	N/A

**Reference Installations (Up to Five):**

1. York River WWTP, Hampton Roads Sanitation District, Seaford, VA (13.7 mgd) – implementing tertiary anammox polishing using denitrification filters

**Estimated Time to Full Scale:** < 5 years



## Key Considerations:

### Practicality of Scaling Technology to Large WWTP: Low

Potential Impacts of Technology					
Parameter	Low	Medium	High	Season	Notes
Effluent N concentration benefit	✓			Year-round	The process will be less efficient than existing denitrification systems as anammox operates at peak efficiency with high nitrogen concentrations and temperatures over 30 deg. C.
Footprint impact		✓			Allows for reduced main-stream process footprint due to tertiary nitrogen removal.
Impacts to other plant processes	✓				Minor additional solids generation in nitrification mode.
Truck traffic impact		✓			
Sustainability					
Energy use	✓				Low aeration requirements relative to conventional denitrification
GHG emissions		✓			Lower electricity and carbon requirements compared to other N removal technologies. Exact impact of greenhouse gas emissions is unknown for Anammox, but some research suggests minimal N <sub>2</sub> O emissions.
Resource recovery benefit					No negative impact on resource recovery options
Relative capital cost		✓			Unknown – no full-scale systems exist for comparison
Relative O&M cost	✓				Unknown but likely low due to comparison with operating side stream anammox systems
Operational complexity			✓		

#### Other Notable Characteristics:

- Alkalinity addition may not be required, dependent on effluent alkalinity.

#### Known Issues/Risks:

- Unproven technology at full-scale.
- Currently unable to achieve low final effluent N concentration

**Applicable KC WTD Plants:**  West Point  South Plant  Brightwater

# Tertiary Denitrification Fixed-Film Processes

**Classification:** Tertiary

## Process Description:

Fixed film processes can be used in tertiary application for support growth of denitrifying organisms to prevent washout and decouple HRT from SRT. With these systems, a fixed film media is required to grow a heterotrophic denitrifying biomass to convert nitrate in the secondary effluent to nitrogen gas after secondary solids separation. Because this fixed film process requires external carbon input for driving the denitrification process, significant additional biomass growth occurs and backwash and solids handling is required. There are multiple types of these systems, each operating slightly differently. The most commonly used of these are the denitrifying biologically active filter (BAF) and denitrifying multi-media filter.

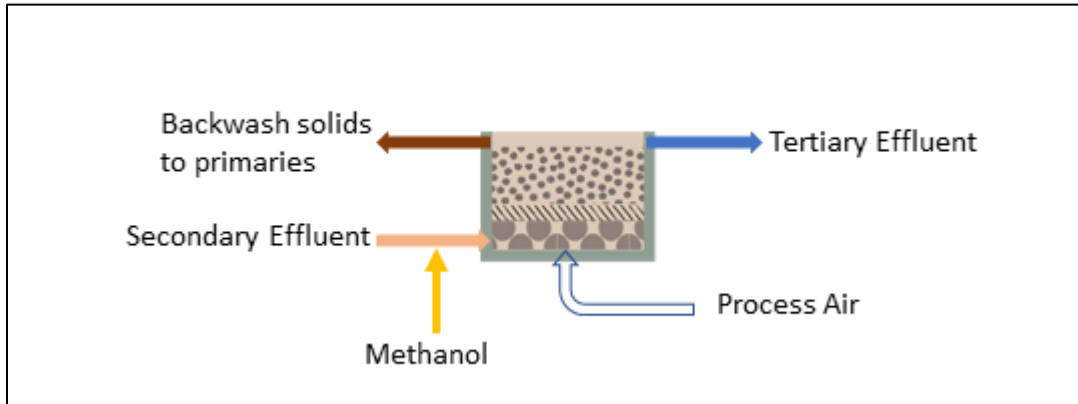

Process flow diagram

**Status:** Established

Number of Installations		
Full scale	Pilot scale	Lab scale
> 20	N/A	N/A

## Reference Installations (Up to Five):

1. New Rochelle, NY (31 mgd, two-stage nitrifying/denitrifying BAF after HPO)
2. Denver, CO (14.6 mgd, denitrifying BAF after HPO)
3. Littleton-Englewood, CO (50 mgd, denitrifying multi-media filter)
4. Tampa, FL (220 mgd, denitrifying multi-media filter)
5. Fairfax, CO (denitrifying MBBR)

**Estimated Time to Full Scale:** N/A

## Key Considerations:

### Practicality of Scaling Technology to Large WWTP: High

Potential Impacts of Technology					
Parameter	Low	Medium	High	Season	Notes
Effluent N concentration benefit			✓	Year-round	High effluent N removal
Footprint impact		✓			These processes also can have significant footprint and would still require tertiary nitrification system.
Impacts to other plant processes	✓				additional solids generation due to external carbon addition.
Truck traffic impact			✓		High chemical requirements for carbon addition
Sustainability					
Energy use			✓		Additional pumping of effluent required, backwash pumping required, nitrification still required as part of main system or other tertiary process
GHG emissions		✓			Carbon addition and transport, potential for N <sub>2</sub> O emissions during denitrification process.
Resource recovery benefit					No negative impact on resource recovery options
Relative capital cost		✓			High capital cost for BAF and equipment. Still require additional nitrification.
Relative O&M cost			✓		Scheduled media replacement needed, carbon addition required
Operational complexity		✓			

#### Other Notable Characteristics:

- Typical effluent quality does not require additional solids separation
- Backwash is required for biofilm control. Backwash and backwash solids will need to be handled.

#### Known Issues/Risks:

- High backwash requirements.
- High solids generation

**Applicable KC WTD Plants:**  West Point  South Plant  Brightwater

# Tertiary Encapsulation/Engineered Biomass

**Classification:** Tertiary

**Process Description:**

Tertiary encapsulation/engineered biomass is a process that uses a customized microbial process encapsulated in some media. There is currently only one manufacturer associated with this technology and the process is known as Microvi MNE™ (MicroNiche Engineering) and has an exclusive licensing agreement with WesTech Engineering. Microvi MNE attempts to intensify biological treatment processes using a customized microbial population housed within free-floating beads. The beads are housed in a vessel with screens to retain the biomass and beads. This allows a high density of active biomass to provide treatment without concern over washout or SRT. Microvi systems were originally developed for subsurface soil remediation and the vendor has successfully transitioned the process to a wastewater environment in limited scale pilot work.

The advantages of Microvi MNE for wastewater treatment as listed by the manufacturer include:

- Compact footprint / Low hydraulic retention times
- Little waste biomass production
- Reduced chemical use
- Resistant to toxins and process upsets due to complete biomass retainage

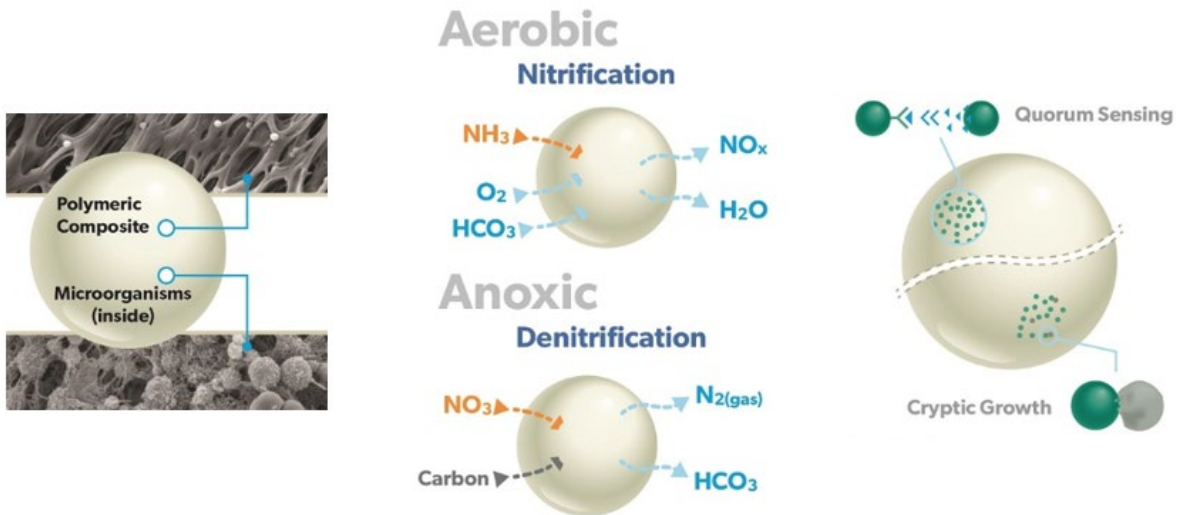

Microvi MNE™ Process

**Status:** Embryonic

Number of Installations		
Full scale	Pilot scale	Lab scale
N/A	<5	N/A

**Reference Installations (Up to Five):**

1. No full scale. Pilot scale installations installed at:
  - a. Sydney Water, Australia
  - b. San Lorenzo, CA
  - c. Unnamed utility in AL

**Estimated Time to Full Scale:** < 5 years

## Key Considerations:

### Practicality of Scaling Technology to Large WWTP: Low

Potential Impacts of Technology					
Parameter	Low	Medium	High	Season	Notes
Effluent N concentration benefit			✓	Year-round	High level of denitrification in pilot systems (TN < 3 mg/L)
Footprint impact	✓				Unknown, but likely small due to encapsulation technology
Impacts to other plant processes	✓				Minor additional solids generation.
Truck traffic impact		✓			
Sustainability					
Energy use		?			Unknown energy use/air requirements. May require significant air for nitrification. Likely required tertiary pumping.
GHG emissions		?			Unknown electricity requirements but likely high because of aeration requirements for nitrification. Potential for some N <sub>2</sub> O emissions during denitrification process.
Resource recovery benefit					No known negative impact on resource recovery options
Relative capital cost			✓		Unknown, but likely high
Relative O&M cost		✓			Claim low O&M, but will probably require chemical use in tertiary application, air for tertiary nitrification, some level of maintenance on bead reactor, bead and microorganism makeup.
Operational complexity		✓			

#### Other Notable Characteristics:

- Tertiary pumping needed as retrofit.
- Pilot scale only.

#### Known Issues/Risks:

- Unproven full-scale technology. Pilot testing for each specific system is required.
- Proprietary technology requiring sole-sourcing
- Unknown how long-term operation affects bead integrity
- Unknown how biomass growth impacts bead integrity and washout
- Unknown carbon addition requirements (likely reduced due to reduced competition)
- Unknown costs for large full-scale application
- Unknown scale-up capability

**Applicable KC WTD Plants:**  West Point  South Plant  Brightwater

## Tertiary Nitrifying Fixed-Film Processes

**Classification:** Tertiary

**Process Description:**

Fixed film processes can be used in tertiary application to support the growth of nitrifying organisms and to prevent washout and decouple HRT from SRT. With these systems, a fixed film media is required to grow a nitrifying biomass to convert ammonia to nitrate in the secondary effluent. Air is added to support nitrifier growth. Little additional biomass is grown due to low growth rates of nitrifiers and lack of carbon for heterotrophic growth. There are multiple types of these systems, each operating slightly differently. The most commonly used of these are the nitrifying biological aerated filter (BAF) and nitrifying moving bed bioreactor (MBBR), and nitrifying trickling filter (NTF).

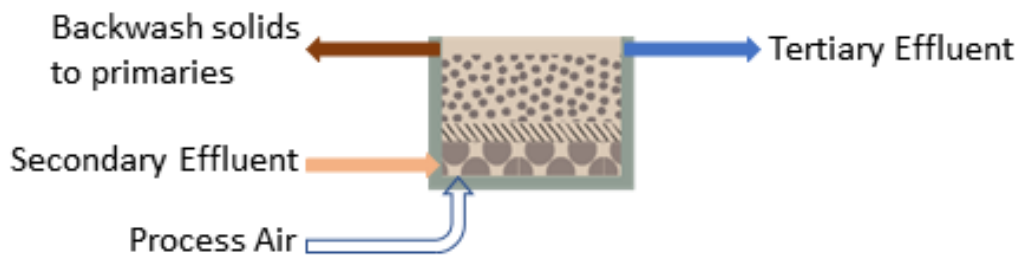

Process flow diagram (example as BAF)

**Status:** Established

Number of Installations		
Full scale	Pilot scale	Lab scale
>20	N/A	N/A

**Reference Installations (Up to Five):**

1. Littleton-Englewood, CO (50 mgd, NTF)
2. Syracuse, NY (110 mgd, nitrifying BAF)
3. Patapsco WWTP, MD (>80 mgd, nitrifying BAF)
4. Binghamton-Johnson City Joint STP, NY (>45 mgd, nitrifying BAF)
5. Moorhead WWTF, MN (4.5 mgd, nitrifying MBBR)

**Estimated Time to Full Scale:** N/A

## Key Considerations:

### Practicality of Scaling Technology to Large WWTP: High

Potential Impacts of Technology					
Parameter	Low	Medium	High	Season	Notes
Effluent N concentration benefit	✓			Year-round	No denitrification occurs in this system.
Footprint impact			✓		Allows for reduced main-stream process footprint due to tertiary nitrification. Still requires additional tertiary denitrification.
Impacts to other plant processes	✓				Minor additional solids generation in nitrification mode.
Truck traffic impact		✓			
Sustainability					
Energy use			✓		High aeration requirements, additional tertiary pumping required.
GHG emissions		✓			High electricity requirements for aeration (except for NTF) and likely requires supplemental alkalinity. Potential for some N <sub>2</sub> O emissions.
Resource recovery benefit					No negative impact on resource recovery options
Relative capital cost			✓		High – additional denitrification required, expensive technology.
Relative O&M cost			✓		Likely high due to energy use, chemical cost and potential for media replacement.
Operational complexity	✓				

#### Other Notable Characteristics:

- Alkalinity addition likely required.
- Tertiary pumping needed as retrofit.

#### Known Issues/Risks:

**Applicable KC WTD Plants:**  West Point  South Plant  Brightwater

# BAF Fixed Film Technology

**Classification:** Intensification

## **Process Description:**

The Biological Aerated Filter (BAF) process is a fixed-film process where some carrier media (styrene beads or expanded clay, dependent on manufacturer) is used to provide a surface for biofilm growth. The primary advantage of the BAF process is the ability to achieve nitrification in the attached biomass, which can reduce the volume required for treatment. A disadvantage of the process is that it requires 2-stage treatment for denitrification, with full chemical addition to the second stage denitrifying BAF – similar to a tertiary fixed film process. However, a more recent possible amendment to this process may allow for simultaneous nitrification and denitrification (SND) within a single stage BAF tower with proprietary controls developed by Veolia for their BioStyr system. The extent of this in practice today is unknown to BC.

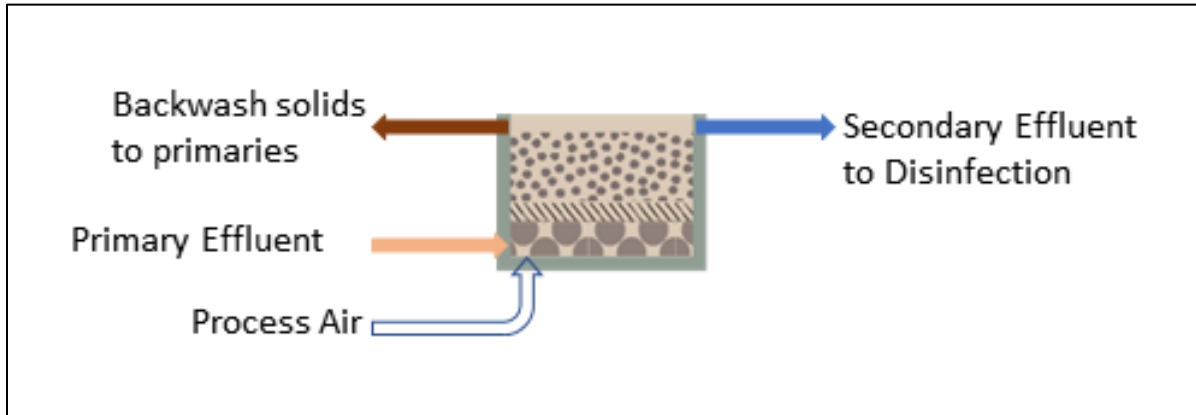

Process flow diagram

**Status:** Established

Number of Installations		
Full scale	Pilot scale	Lab scale
> 10 (non SND)	N/A	N/A

## **Reference Installations (Up to Five):**

1.

**Estimated Time to Full Scale:** N/A



## Key Considerations:

### Practicality of Scaling Technology to Large WWTP: High

Potential Impacts of Technology					
Parameter	Low	Medium	High	Season	Notes
Effluent N concentration benefit				Year-round	N removal capability depends on BAF process configuration
Footprint impact		✓			Allows operation for nitrification in reduced footprint
Impacts to other plant processes			✓		Would require abandonment of existing secondary system. High backwash requirements puts more emphasis on recycle flows and potential for capacity limitations in primary clarifiers.
Truck traffic impact		✓			Dependent on mode of operation. SND would have lower impact. 2 stage denitrification with carbon addition would be high impact.
Sustainability					
Energy use			✓		High aeration demands (potential savings in SND mode). Additional pumping required.
GHG emissions			✓		High electricity requirements for aeration and extra pumping. Potential for some N <sub>2</sub> O emissions during nitrification/denitrification processes. Higher potential when in SND mode.
Resource recovery benefit					No negative impact on resource recovery options
Relative capital cost			✓		Potential to shrink main process footprint, but capital cost of proprietary media, aeration upgrades, pumping, etc.
Relative O&M cost			✓		High aeration demands, high pumping demands, potential for large carbon requirement.
Operational complexity		✓			

#### Other Notable Characteristics:

- Proprietary media and equipment with limited manufacturers available
- Operation as fixed film process reduces or eliminates need for secondary clarification, with near elimination of bulking filamentous growth as well.

#### Known Issues/Risks:

- High backwash requirements puts strain on primary clarification during peak flow events.
- Potential for issues with primary clarification due to inclusion of backwash recycle (active biomass) entering primary clarifiers.
- Past incidents of aggressive process design resulting in reduced system capacity.

**Applicable KC WTD Plants:**  West Point  South Plant  Brightwater

Exact size/footprint savings with this system are unknown at this time because of limited full-scale application of the technology in SND mode. In 2-stage mode, footprint savings would be minimal and impacts to other processes significant. To realize the same footprint savings as an MBR process, BAF may need to be coupled with a carbon diversion technology like CEPT or ballasted primary sedimentation to further reduce carbon addition to the secondary process (but likely still has significant energy and capital expense). Because of footprint availability at South Plant and pre-existing MBR at Brightwater, this technology does not make sense for these facilities. Therefore, it should only be potentially considered for West Point as an alternative to MBR for intensification, and should also only be considered if SND mode of operation is deemed viable for this technology.

# Ballasted Sedimentation (BioMag®)

**Classification:** Intensification

**Process Description:**

BioMag is a ballasted sedimentation wastewater treatment process that uses magnetite to increase the specific gravity of biological floc. Magnetite ( $Fe_3O_4$ ) is an inert iron ore, with a specific gravity of 5.2 and a strong affinity for biological solids. Magnetite substantially increases the settling rate of the biomass. This provides the opportunity to increase the active MLSS concentration in the biological system (up to approximately 10,000 mg/L), while still maintaining adequate settling and thickening in the secondary clarifiers.

In the BioMag process, virgin and recovered magnetite are blended with mixed liquor or RAS in the magnetite mix tank. The ballasted mixed liquor then flows to the aeration tank, and then on to secondary clarification, where the solids settle and thicken. Most of the resultant sludge (with ballast) is returned to the aeration tank via the RAS line. WAS is pumped through a shear mill and then to the magnetic recovery drum, where the ballast is recovered and sent for blending with the mixed liquor in the magnetite mix tank. The excess biological solids, minus the magnetite, are wasted to sludge processing.

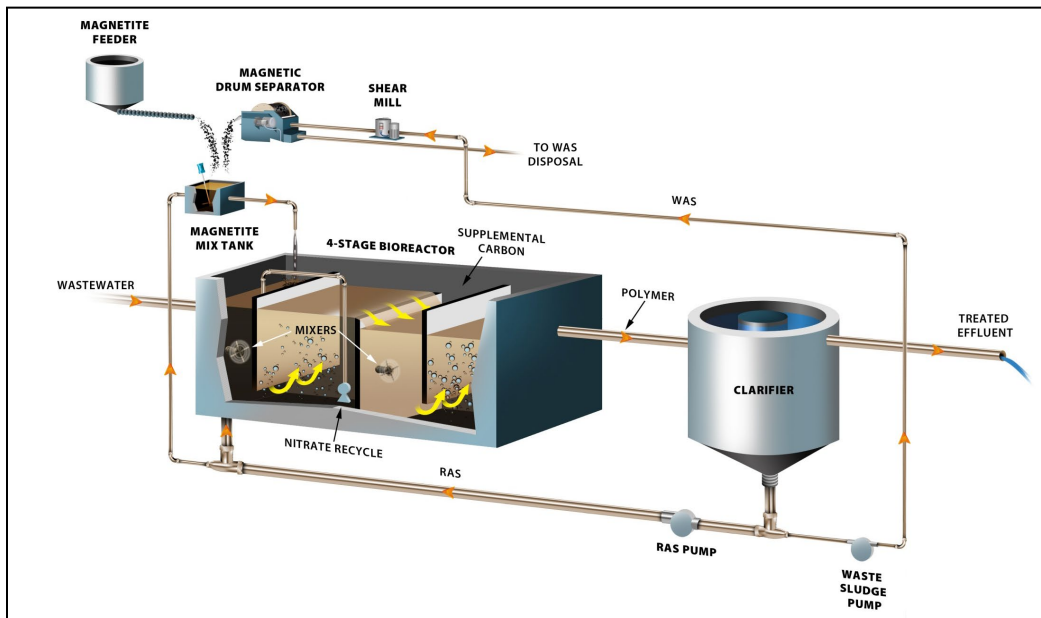

**Process flow diagram for BioMag**

*Courtesy of Evoqua.*

**Status:** Established

Number of Installations		
Full scale	Pilot scale	Lab scale
> 10	N/A	N/A

**Reference Installations (Up to Five):**

1. Marlay Taylor Water Reclamation Facility, Ocean City, MD (6 mgd average)
2. Sturbridge WWTP, Sturbridge, MA (1.3 mgd)
3. Winebrenner WWTP, MD (0.6 mgd)
4. Upper Gwynedd WWTP, PA (3 mgd)
5. East Norriton-Plymouth-Whitpain WWTP, Plymouth Meeting, PA (8.7 mgd)

**Estimated Time to Full Scale:** N/A

## Key Considerations:

### Practicality of Scaling Technology to Large WWTP: Medium

Potential Impacts of Technology					
Parameter	Low	Medium	High	Season	Notes
Effluent N concentration benefit				Year-round	N removal capability depends on main biological treatment process that is used
Footprint impact	✓				Allows aeration basins to be operated at ~3x mixed liquor concentrations (8,000-10,000 mg/L)
Impacts to other plant processes		✓			May need to consider fate of lost magnetite in biosolids processes, such as potential for accumulation in digesters
Truck traffic impact		✓			
Sustainability					
Energy use		✓			Likely increased energy use (additional mixing, magnetite recovery equipment, aeration, etc.)
GHG emissions		✓			High electricity requirements for aeration and mixing, and replacement magnetite is required. Expect relatively low N <sub>2</sub> O emissions depending on process configuration and aeration strategy.
Resource recovery benefit					No negative impact on resource recovery options
Relative capital cost			✓		High capital cost for vendor equipment
Relative O&M cost		✓			Likely increased energy use (see above) and cost of replacement magnetite
Operational complexity		✓			

#### Other Notable Characteristics:

- Continual loss of magnetite to effluent and WAS recovery process must be replenished (greater than 95 percent recovery), or approximately 100-150 lb/d/mgd
- Manufacturer claims improved WAS thickening performance after processing WAS in shear mills
- Typically 1–1.2 magnetite:MLSS ratio (by weight), optimized during startup
- Requires approximately two weeks to charge the system
- Average SVIs of 45–65 mL/g are typical
- Low effluent TSS

#### Known Issues/Risks:

- Magnetic recovery process returns approximately 25 percent of biological solids back to process, so must be accounted for in SRT calculations
- Lack of installations for large WWTPs
- Number of units required for WAS magnetite recovery (shear mills, magnetic recovery drums, etc.) could be extensive for large WWTPs
- WAS screening may be required upstream of shear mills (manufacturer recommends 2-mm sludge screen upstream of shear mill if headworks screens greater than 2-mm opening)
- Additional mixing energy for unaerated zones and potential for supplemental mixing energy needed for aerated zones
- Increase RAS pumping rate periodically to minimize deposition in RAS piping

**Applicable KC WTD Plants:**  West Point  South Plant  Brightwater

## Partial Granulation

**Classification:** Intensification

**Process Description:**

Aerobic granular sludge processes select for dense sludge pellets that have fast settling rates, which allows operation at high MLSS concentrations and shrinks process footprint. Mature granules are typically 1–2 mm in diameter and are composed of a diverse population of microorganisms. However, smaller granules can be formed under selection and provide some settling benefit. There are two current methods for granule formation. The first, and only commercially available system today, selects for heavier flocs using hydrocyclone technology on the WAS stream. In this case, the heaviest flocs are retained and only the light material is wasted. Over time, this leads to granule formation by continually selecting for heavier and heavier floc material. The result is an activated sludge that contains up to 50 percent granules, with significantly improved SVI (less than 75 mL/g) and higher clarifier solids loading rates (50-60 lb/d-ft<sup>2</sup>), resulting in a footprint savings of approximately 50 percent. This is currently being used by Denver Metro and the technology is commercially available from World Water Works (inDENSE™ process).

The second method for granulation in the main stream is by operating a sidestream granulation reactor that seeds granules into the mainstream process. This is currently being researched at West Point WWTP in conjunction with the University of Washington and has shown promise as a new process.

In each case, the mainstream process remains as a conventional denitrification process (MLE, SND, 4SMB).

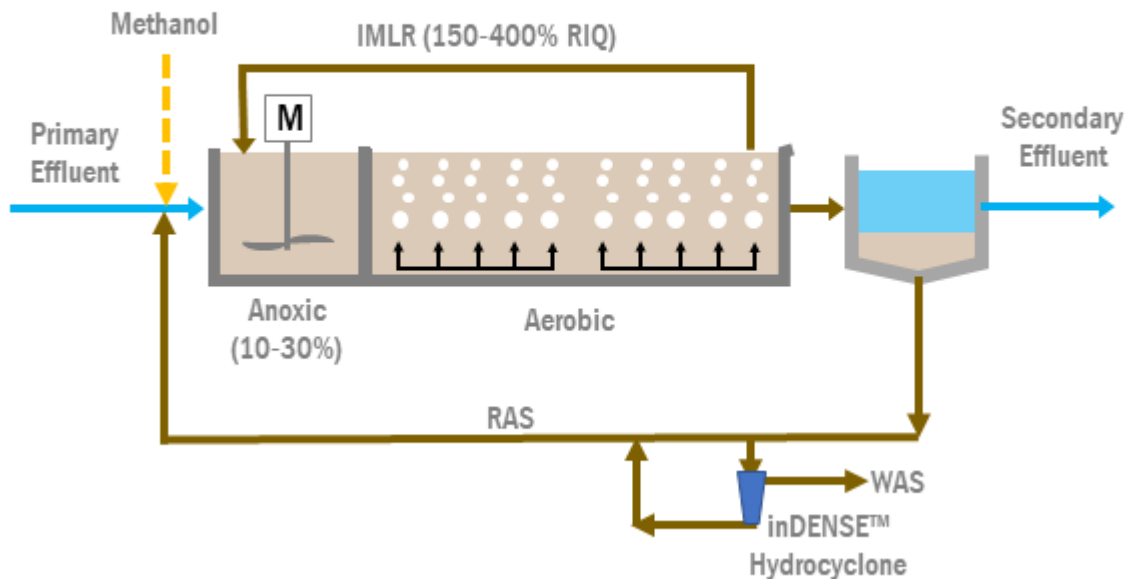

**Process flow diagram of MLE process with inDENSE™ partial granulation**

**Status:** Innovative

Number of Installations		
Full scale	Pilot scale	Lab scale
<5	Various North America pilots	N/A

**Reference Installations (Up to Five):**

1. Denver Metro, Robert Hite WWTP (220 mgd)
2. Urbana WWTP, HRSD, Virginia (< 1 mgd)

**Estimated Time to Full Scale:** N/A

**Key Considerations:**

**Practicality of Scaling Technology to Large WWTP:** Medium

Potential Impacts of Technology					
Parameter	Low	Medium	High	Season	Notes
Effluent N concentration benefit			✓	Year-round	Capable of achieving very low effluent TN and TP, dependent on main stream process configuration
Footprint impact	✓				Potential for up to 50% footprint savings based on current information
Impacts to other plant processes		✓			Potential for reduced wasting
Truck traffic impact	✓				
Sustainability					
Energy use		✓			Some improvement in energy due to granules and SND, but additional mixing likely required
GHG emissions		✓			Lower overall electricity and carbon requirements. Exact impact of granular sludge operation on N <sub>2</sub> O emissions is unclear but some research suggests low emissions of N <sub>2</sub> O from other granulation processes.
Resource recovery benefit		✓			Potential for P recovery if performing bio-P
Relative capital cost	✓				High capital cost for proprietary equipment and licensing fees, but low relative to other technologies
Relative O&M cost		✓			Energy savings, potential for reduced wasting, but additional mixing required.
Operational complexity		✓			Low for inDENSE, higher for sidestream granulation system

**Other Notable Characteristics:**

- Ability to operate at high MLSS concentrations
- Additional mixing likely required due to denser and faster settling sludge
- Easy retrofit into existing systems
- Granule structure is resistant to toxicity

**Known Issues/Risks:**

- InDENSE system has limited benefit when operating at low SRT (based on information from HRSD)
- Untested in non-bio-P systems
- Long startup (months) required to form sufficient quantity of mature granules to improve operation

**Applicable KC WTD Plants:**  West Point  South Plant  Brightwater

# Hybrid Fixed-Film/Ballast

**Classification:** Intensification

**Process Description:**

Hybrid fixed-film/ballast processes are like IFAS/MBBR except they use organic media to support biofilm growth instead of plastic media. In addition, the media is not retained in the aeration basins but rather goes through the secondary clarifiers, where the media also acts as a ballast to increase settling rates. Media settles in the secondary clarifier and is returned to the head of the process via the RAS. A screen on the WAS line is used to recover the organic media and return it to the process. Hybrid fixed-film/ballast processes are currently offered by at least two vendors, including Nuvoda (Mobile Organic Biofilm [MOB™]) and Smith & Loveless [Green+Green™]. Vendors supply the organic media and the WAS screening equipment. In the case of Nuvoda’s MOB process, the organic media is a lignocellulosic material that is harvested from kenaf plants, which are reportedly fast-growing plants similar to bamboo.

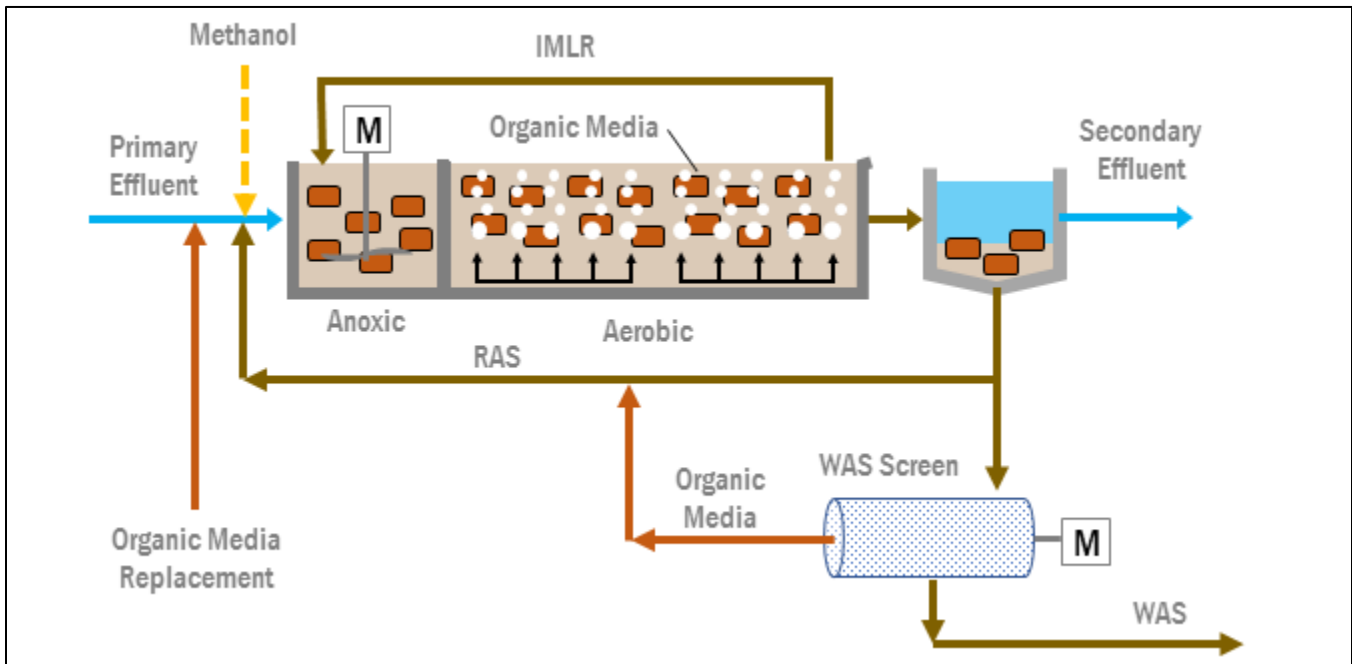

Process flow diagram (example MLE process with MOB technology)

**Status:** Innovative

Number of Installations		
Full scale	Pilot scale	Lab scale
> 10	Various	N/A

**Reference Installations (Up to Five):**

1. Nuvoda: Moorfield, WV (3.4 mgd average, 6.2 mgd peak)
2. Nuvoda: Town of Stantonburg
3. Nuvoda: Mebane
4. Nuvoda: Roanoke, VA
5. Nuvoda: Westlake, VA

**Estimated Time to Full Scale:** N/A

## Key Considerations:

### Practicality of Scaling Technology to Large WWTP: Low

Potential Impacts of Technology					
Parameter	Low	Medium	High	Season	Notes
Effluent N concentration benefit				Year-round	N removal capability depends on process configuration
Footprint impact		✓			Allows operation at reduced SRT for nitrification and reduced clarification requirements
Impacts to other plant processes		✓			Uncertainty of WAS thickening/digestion impacts
Truck traffic impact		✓			
Sustainability					
Energy use		✓			Aeration/mixing requirements would need to be evaluated
GHG emissions		✓			Likely high electricity requirements for aeration and mixing. Potential for some N <sub>2</sub> O emissions during nitrification/denitrification processes.
Resource recovery benefit					No negative impact on resource recovery options
Relative capital cost		✓			Potential to shrink main process footprint and reduce number of secondary clarifiers required. Additional WAS screening and cost of media.
Relative O&M cost		✓			Aeration/mixing requirements would need to be evaluated. Additional WAS screening equipment. Low media replacement rates expected.
Operational complexity		✓			

#### Other Notable Characteristics:

- Vendors claim that the lignocellulosic media does not break down under conditions in typical activated sludge basins, but would require extended anaerobic digestion to break down
- Nuvoda claims a 100-percent capture of their kenaf media with secondary clarifiers and the WAS screening system, but suggests a typical media replacement rate of 2 percent annually
- Nuvoda uses a 500-micron (0.5 mm) rotary drum screen (Parkson or similar) for WAS screening
- Organic media produced from renewable resource and is biodegradable (unlike plastic media typically used for IFAS/MBBR systems)

#### Known Issues/Risks:

- Limited applications at municipal WWTPs (Nuvoda did suggest that the technology is currently being considered for a large WWTP in New Zealand)
- Uncertainty of impacts to downstream WAS thickening systems (change in WAS characteristics, potential dilution from screens spray water, etc.)
- Would need to confirm aeration/mixing requirements to keep media in suspension and provide sufficient DO to support nitrifying biofilm (Nuvoda claims DO of 1–1.5 mg/L is sufficient and that the MOB process is compatible with fine bubble diffusers and any type of mixer)

**Applicable KC WTD Plants:**  West Point  South Plant  Brightwater

## Integrated Fixed-Film Activated Sludge (IFAS)/ Moving Bed Biofilm Reactor (MBBR)

**Classification:** Intensification

**Process Description:**

The IFAS process is a combination of fixed-film and suspended growth activated sludge, where plastic media are added to aeration basins to provide a surface for biofilm growth. The media may be a loose-fill type such as a hollow ring form, which is suspended in the mixed liquor by aeration-induced mixing, or it may be built-in-place within the aeration tank as in the case of a fixed-trellis arrangement. Where loose-fill media is used, aeration basins are equipped with cylindrical sieves to retain media. The primary advantage of an IFAS process is the ability to achieve nitrification at lower SRTs (with respect to the suspended biomass), since nitrification can occur in both the suspended biomass and in the attached biomass. Operating at a reduced SRT allows a reduction in required aeration basin volume.

The MBBR process differs from the IFAS process in that it does not employ a RAS stream for mixed liquor seeding. It therefore operates at a much lower bulk liquid MLSS concentration and relies more heavily on the media biofilm for treatment performance, thereby reducing solids loading on the downstream clarifiers.

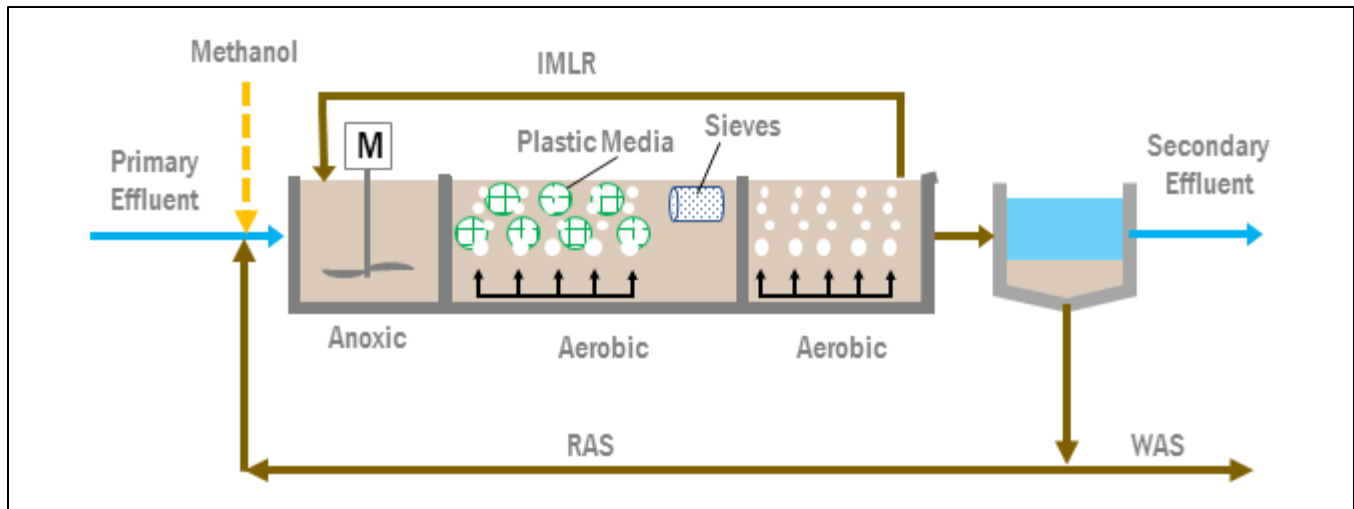

Process flow diagram (example of MLE process with IFAS media at front end of aerobic zone)

**Status:** Established

Number of Installations		
Full scale	Pilot scale	Lab scale
> 50	N/A	N/A

**Reference Installations (Up to Five):**

1. IFAS: Twin Falls WWTP, Twin Falls, ID (9.5 mgd)
2. IFAS: Bend WRF, Bend, OR (> 8 mgd)
3. IFAS: Broomfield WWTP, CO (12 mgd)
4. IFAS: Dry Creek WWTP, Cheyene, WY (12 mgd, MLE configuration)
5. MBBR: Williams Monaco WWTP, Henderson, CO (7 mgd, MLE configuration)

**Estimated Time to Full Scale:** N/A



## Key Considerations:

### Practicality of Scaling Technology to Large WWTP: High

Potential Impacts of Technology					
Parameter	Low	Medium	High	Season	Notes
Effluent N concentration benefit				Year-round	N removal capability depends on IFAS/MBBR process configuration
Footprint impact		✓			Allows operation at reduced SRT for nitrification
Impacts to other plant processes		✓			
Truck traffic impact		✓			
Sustainability					
Energy use			✓		High aeration demands
GHG emissions		✓			High electricity requirements for aeration. Potential for some N <sub>2</sub> O emissions during nitrification/denitrification processes.
Resource recovery benefit					No negative impact on resource recovery options
Relative capital cost		✓			Potential to shrink main process footprint, but capital cost of proprietary media, aeration upgrades, sieves, etc.
Relative O&M cost			✓		High aeration demands
Operational complexity		✓			

#### Other Notable Characteristics:

- Medium bubble diffusers are usually required to provide sufficient turbulence for mixing and avoid potential damage to membranes of fine bubble diffusers
- IFAS does not typically offer significant savings in tank volumes unless nitrification at cold winter temperatures is required (e.g., less than 12°C) and/or the system is operated at a low enough SRT to promote nitrifier growth on the media rather than just the suspended biomass (resulting in nitrifier washout from the suspended biomass)
- Proprietary media and equipment but many suppliers available

#### Known Issues/Risks:

- Risk of filamentous bulking in IFAS systems with insufficient aeration (low DO and high substrate)
- High aeration requirement for mixing and DO concentration (aerobic zones typically operated at DO of 3–5 mg/L to develop a concentration gradient sufficient to pass oxygen into the biofilm)
- Potential for foam trapping with submerged flow through sieves
- Potential for plugging and increased head loss through sieves
- Past incidents of hydraulic failures at media retention screens, particularly during peak wet weather events

**Applicable KC WTD Plants:**  West Point  South Plant  Brightwater

# Membrane Aerated Biofilm Reactor (MABR)

**Classification:** Intensification

**Process Description:**

The MABR process uses a gas permeable membrane to supply oxygen to a biofilm that grows on the membrane surface. Air is introduced through the membrane filaments and oxygen diffuses out through the biofilm. The membranes are typically added to unaerated zones to allow nitrification and denitrification to occur in the same reactor, with anoxic conditions in the suspended biomass and aerobic conditions in the biofilm. Ammonia diffuses into the biofilm and nitrifiers grow on the surface of the membrane media closest to the oxygen source. In addition, the membrane diffusion allows oxygen transfer to the biofilm at high transfer efficiencies (approximately 3–4 times more efficient than fine bubble diffusers). Vendors currently offering MABR technology include SUEZ (formerly GE Water and Process Technologies), OxyMem, and Fluence.

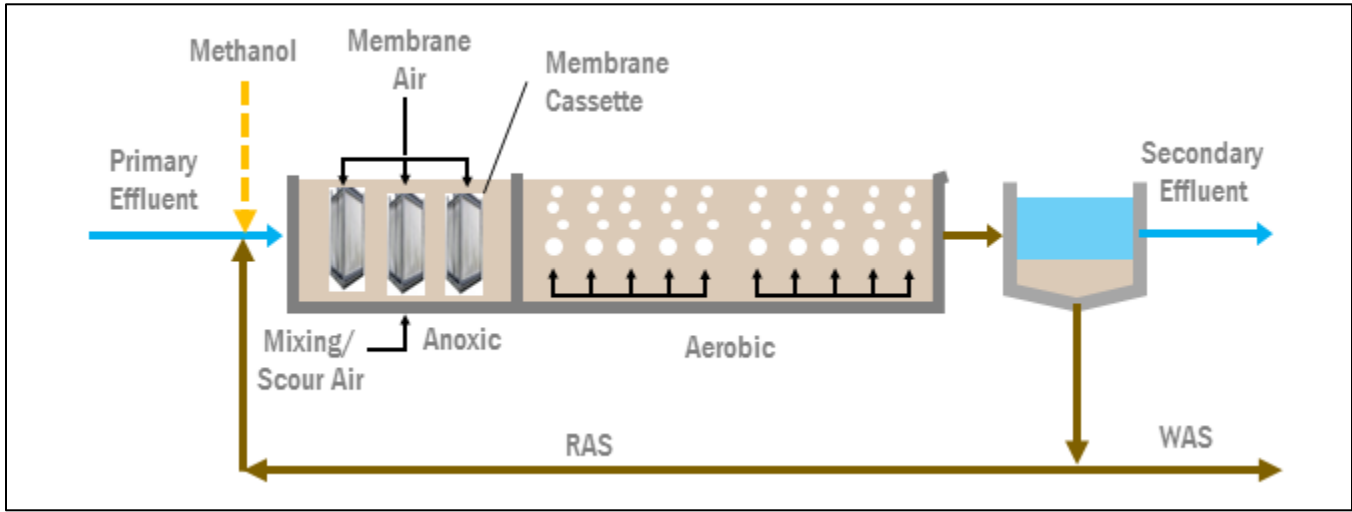

Process flow diagram (example MABR cassettes installed in anoxic zone)

**Status:** Innovative

Number of Installations		
Full scale	Pilot scale	Lab scale
1	> 5	N/A

**Reference Installations (Up to Five):**

1. Yorkville-Bristol Sanitary District, IL (3.5 mgd, anaerobic/anoxic/oxic process)
2. O'Brien Water Reclamation Plant, Chicago, IL (demonstration pilot)
3. Various other pilots in North America and Europe

**Estimated Time to Full Scale:** N/A

## Key Considerations:

### Practicality of Scaling Technology to Large WWTP: Medium

Potential Impacts of Technology					
Parameter	Low	Medium	High	Season	Notes
Effluent N concentration benefit				Year-round	N removal capability would depend on process configuration
Footprint impact		✓			Potential to reduce required SRT
Impacts to other plant processes		✓			Likely requires fine screening to protect the membranes
Truck traffic impact		✓			
Sustainability					
Energy use		✓			Potential aeration energy savings and elimination of IMLR, but overall energy reduction not yet definitive from current pilot- and full-scale installations
GHG emissions		✓			Potential reduction in electricity requirements for aeration because of improved transfer efficiency, but requires mixing/scour air. Chemicals not required for membrane cleaning. Potential for some N <sub>2</sub> O emissions, likely depending on process configuration and operating strategy.
Resource recovery benefit					No negative impact on resource recovery options
Relative capital cost			✓		Likely high capital cost (installed cost of approximately \$5M for 3.5-mgd Yorkville installation)
Relative O&M cost		✓			Potential energy savings, longer membrane life expected but still not clear
Operational complexity			✓		

#### Other Notable Characteristics:

- Scouring of biofilm from the membrane media provides a bioaugmentation effect, where nitrifiers from the fixed-film seed the suspended biomass
- Potential aeration savings
- Maximum oxygen transfer efficiencies with membranes at front of process in unaerated zones
- Intermittent scour/mixing air required in MABR zones, likely with supplemental mixing
- May need separate blowers for membrane air and mixing/scour air
- Unlike MBR, membranes not subjected to hypochlorite-based cleaning and have lower scour airflows (expect potential extended life of membranes)
- SUEZ claim potential to reduce SRT by 2 days for systems for higher rate systems (higher effluent ammonia requirements)

#### Known Issues/Risks:

- Membrane permeability may decrease over time as the membrane ages (potential for reduced oxygen transfer efficiency)
- Solids deposition in membrane and red worms (need to optimize mixing and air scour frequency/duration)

**Applicable KC WTD Plants:**  West Point  South Plant  Brightwater

# Membrane Bioreactor (MBR)

**Classification:** Intensification

**Process Description:**

MBRs operate with highly concentrated mixed liquor (MLSS concentration of approximately 10,000 mg/L), allowing biological performance goals to be met within a smaller basin volume. The MBR configuration does not require secondary clarifiers for solids separation. Rather, a microfiltration or ultrafiltration membrane is used to separate solids from the secondary effluent, resulting in a further reduction in site footprint requirements. However, MBRs typically have high capital costs and higher operational costs than activated sludge with traditional secondary clarifiers. The operational costs are primarily associated with aeration demand required for membrane scouring.

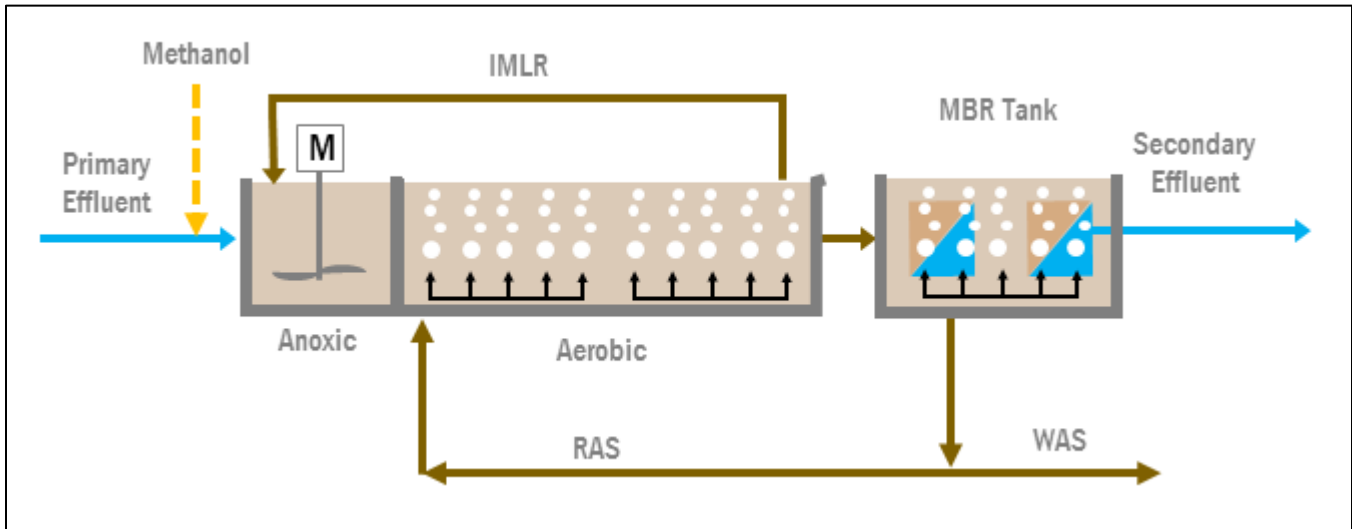

Process flow diagram (example of MLE process with MBR for solids separation)

**Status:** Established

Number of Installations		
Full scale	Pilot scale	Lab scale
> 50	N/A	N/A

**Reference Installations (Up to Five):**

1. Brightwater Treatment Plant, King County, WA (30 mgd peak month design flow)
2. Lighthouse Point Water Reclamation Facility, Blaine, WA (1.5 mgd)
3. Picnic Point Treatment Facility, Alderwood Water and Wastewater District, Lynwood, WA (4.1 mgd peak month design flow)
4. Duvall WWTP, Duvall, WA (1.3 mgd)
5. Martin Way SRP, LOTT Clean Water Alliance, Lacey, WA (2 mgd average)

**Estimated Time to Full Scale:** N/A

## Key Considerations:

### Practicality of Scaling Technology to Large WWTP: High

Potential Impacts of Technology					
Parameter	Low	Medium	High	Season	Notes
Effluent N concentration benefit				Year-round	N removal capability depends on main biological treatment process that is paired with the MBR
Footprint impact	✓				Allows aeration basins to be operated at ~3x mixed liquor concentrations and eliminates secondary clarifiers
Impacts to other plant processes		✓			MBR would replace need for secondary clarifiers at West Point and South Plant, or require parallel MBR train. Upstream fine screening would be required.
Truck traffic impact		✓			
Sustainability					
Energy use			✓		High aeration demands and operation of permeate pumps
GHG emissions		✓			High electricity requirements for aeration and pumping and chemicals required for membrane cleaning. Expect relatively low N <sub>2</sub> O emissions depending on process configuration and aeration strategy.
Resource recovery benefit			✓		Flexibility for reclaimed water production (MBR provides filtration step)
Relative capital cost			✓		High capital cost for MBR equipment
Relative O&M cost			✓		High aeration demands and chemical costs for membrane cleaning
Operational complexity		✓			

#### Other Notable Characteristics:

- Requires chemicals for membrane cleaning (e.g., hypochlorite, citric acid, etc.)
- Requires fine screening to protect the membranes

#### Known Issues/Risks:

- RAS from MBR tank has high DO concentration that will negatively impact anoxic selectors for N removal (avoid sending RAS to anoxic zone or reduce residual DO concentration before sending to anoxic zone)
- Membrane fouling
- Membrane filterability lower than design capacity
- Potential for higher oxygen transfer requirements (aeration alpha, which is the ratio of oxygen transfer in process conditions vs. clean water, typically declines with increasing MLSS concentration)

**Applicable KC WTD Plants:**  West Point  South Plant  Brightwater

Note: Brightwater already operates using an MLE/MBR configuration with 8 operating membrane basins.

# Carbon Diversion Technologies

**Classification:** Carbon Diversion

## **Process Description:**

Carbon diversion processes allow for removal of some carbon and diverting it straight to anaerobic digestion processes. This has the benefit of reducing footprint and aeration requirements for mainstream processes. Depending on the capture efficiency of the carbon diversion process, it may be capable of removing 75 percent of the influent BOD from secondary treatment. Some carbon diversion processes have the capability of removing only the particulate BOD, leaving soluble BOD for nutrient removal. However, other technologies remove soluble BOD preferentially, stripping it from use in nutrient removal processes. Each of these technologies has a significant impact on solids handling processes, requiring additional solids and biogas handling capacity to be constructed. The following are types of carbon diversion processes:

1. A stage/B stage – this is a high rate reactor operated at less than 1-day SRT (A stage) followed by solids separation, then a longer SRT reactor (B Stage) for solids and BOD polishing followed by final solids separation. The A stage allows for some particulate contact sorption as well as uptake of soluble BOD, which can then be wasted to solids handling processes, diverting carbon rich WAS for biogas production.
2. Chemically enhanced primary treatment (CEPT) – this process is used at Brightwater for stormflow treatment. However, when used as a year-round process, it can divert additional particulate BOD to solids handling and away from the liquid process. It also can reduce footprint of primary treatment processes. However, CEPT has a large chemical demand and also diverts large quantities of inert solids into the solids handling processes.
3. Primary filtration – like CEPT, this process removes large quantities of particulate BOD. There are several filtration technologies, including rotating belt filter (Salsnes), rotating drum filters, and rotating disc filters. This process eliminates the need for primary clarification and can save footprint. It also does not generate significant inert solids as CEPT does. However, cost and power requirements for these systems can be high.
4. Anaerobic technologies – high rate anaerobic treatment systems, like upflow anaerobic sludge blanket reactors (UASBR) have the ability to uptake soluble and particulate BOD and degrade it anaerobically. This diverts the carbon from the secondary processes and reduces footprint. However, these also divert soluble carbon needed for driving nutrient removal processes.

**CEPT and primary filtration were retained for analysis, while A Stage/B Stage and anaerobic technologies were eliminated because they remove soluble BOD that will be needed to drive nitrogen removal.**

**Status:** Established

Number of Installations		
Full scale	Pilot scale	Lab scale
> 50	N/A	N/A

## **Reference Installations (Up to Five):**

1. Brightwater Treatment Plant, King County, WA (CEPT)
2. North End Treatment Plant, Tacoma, WA (CEPT)
3. Daphne, AL (Salsnes)
4. Multiple primary filtration plants in CA (AquaPrime filters)

**Estimated Time to Full Scale:** N/A

## Key Considerations:

**Practicality of Scaling Technology to Large WWTP:** High (CEPT), Medium (primary filtration)

Potential Impacts of Technology					
Parameter	Low	Medium	High	Season	Notes
Effluent N concentration benefit				Year-round	Not N removal technologies
Footprint impact	✓				Replaces or reduces footprint of existing primary clarifiers. Diverts BOD from main process and reduces needed aeration basin volume
Impacts to other plant processes		✓ (Primary filtration)	✓ (CEPT)		Significant increase in biosolids and biogas production, leading to upsizing of digestion and biogas handling systems. CEPT increases inert solids entering biosolids processes.
Truck traffic impact		✓ (Primary filtration)	✓ (CEPT)		
Sustainability					
Energy use	✓				Power use is higher than traditional primary clarification, but still lower than aeration power requirements. Improves potential for energy generation, decreasing reliance on outside energy sources.
GHG emissions	✓ (Primary filtration)	✓ (CEPT)			Low power and diversion of carbon from aeration demands should reduce GHG emissions. CEPT has higher GHG emissions associated with high chemical use.
Resource recovery			✓		Carbon diversion increases biogas generation
Relative capital cost		✓ (CEPT)	✓ (Primary filtration)		High capital cost for filter equipment and abandonment of primary clarifiers. Primaries may be reused elsewhere. If CEPT, then capital cost for implementation is low.
Relative O&M cost		✓ (Primary filtration)	✓ (CEPT)		O&M cost is higher than traditional primary clarification because of increased power use. Filter maintenance can be significant relative to existing primary clarifier collector maintenance. If CEPT is used, chemical use makes O&M cost high.
Operational complexity	✓ (CEPT)	✓ (Primary filtration)			

## Other Notable Characteristics:

### Known Issues/Risks:

- Solids deposition in digestion with CEPT is possible with undermixing.

**Applicable KC WTD Plants:**  West Point  South Plant  Brightwater

Note: Brightwater already has CEPT system in place.

## **Attachment B: Workshop Matrices**

---



Screening Criteria <sup>1</sup>	Mainstream					Sidestream					Tertiary				Intensification						Carbon Diversion										
	Modified Ludzack-Ettinger (MLE) - Brightwater currently operates MLE/MBR process	Four-Stage Modified Bardenpho (4SMB)	Simultaneous Nitrification-Denitrification (SND) - selected for optimization project	Anammox	Aerobic Granular Sludge	Anammox	Shortcut N Removal	Bioaugmentation	Post Aerobic Digestion (PAD)	Ammonia Recovery Processes (Phys/Chem)	Nitrifying Fixed Film Processes	Denitrification Fixed Film Processes	Anammox Polishing Process	Algae Treatment	Encapsulation/Engineered Biomass	Membrane Bioreactor (MBR)	Integrated Fixed-Film Activated Sludge (IFAS)/ Moving Bed Biofilm Reactor (MBBR)	Ballasted Sedimentation (BioMag®)	Hybrid Fixed-Film/Ballast	Partial Granulation	Membrane Aerated Biofilm Reactor (MABR)	Chemically Enhanced Primary Treatment (CEPT) - Brightwater currently operates CEPT system	Primary Filtration								
Technology status <sup>2</sup>	3	3	3	Fail	Not applicable to Brightwater.	3	3	3	2	Fail	Not applicable to Brightwater.	3	Fail	1	Fail	Brightwater already operates MBR process for intensification. However, partial granulation remains of interest per workshop on 4/4/19 and will be retained for further evaluation. Other intensification technologies are not or would likely not be compatible with MBR technology and are eliminated.						3	3								
Scalability to large WWTP	3	3	3	1		3	3	3	3	3		1	3	1	1							1	3	1	1	1	3	2			
Effluent N concentration	2	3	3	1		1	1	1	1	1		1	3	1	3							3									
Load variation impact	2	2	2	1									3	1	2															3	3
Flow variation impact	2	2	2	2									2	2	2							2								3	2
Footprint <sup>3</sup>	1	1	1	1		3	2	2	1	2		2	2	2	1							3								3	3
Impacts to other processes <sup>4</sup>	3	3	3	2		3	3	3	3	2		2	3	3	3							3								1	2
Truck traffic																															
Energy use	2	2	3	3		3	2	2	1	1		1	1	3	2							2								3	3
GHG emissions	2	2	1	2		2	1	2	2	1		2	2	2	2							2								2	3
Resource recovery <sup>5</sup>	2	2	2	2		2	2	2	2	3		2	2	2	3							2								3	3
Capital cost <sup>6</sup>	2	2	2	2		2	2	3	1	1		2	2	2	1							1								2	1
O&M cost	3	2	3	3		3	2	2	2	1		1	1	3	2							2								1	2
Constructability	2	2	2	1		3	3	3	3	3		3	3	3	3							3								3	2
Operational complexity	3	3	2	1		2	1	3	2	1		2	2	1	2							2								3	2
Overall	32	32	32	Fail	N/A	30	25	29	23	Fail	N/A	32	Fail	28	Fail	N/A	N/A	N/A	N/A	N/A	N/A	33	31								

Notes:

- Scale of 1 to 3, where 3 represents the greatest benefit or lowest cost, footprint, emissions, etc.
- Fail if the technology is not expected to be proven at full scale within the next five years, the technology presents too much risk, etc.
- Fail if it is clear that the technology will not be able to fit on the WWTP site.
- Fail if the technology will have unacceptable impacts to other plant processes or impacts that will be difficult to accommodate.

5. Resource recovery includes nutrient recovery (N or P), flexibility for future reclaimed water production (TN limits, filtration, etc.), energy recovery, etc. "1" indicates detrimental to resource recovery, "2" indicates no impact to potential for resource recovery, "3" indicates some benefit to resource recovery inherent in the technology.

6. Mainstream capital cost assumes additional tankage and no intensification. If intensification is added, this has the potential to decrease capital cost.

Screening Criteria <sup>1</sup>	Mainstream					Sidestream					Tertiary					Intensification					Carbon Diversion		
	Modified Ludzack-Ettinger (MLE)	Four-Stage Modified Bardenpho (4SMB)	Simultaneous Nitrification-Denitrification (SND)	Anammox	Aerobic Granular Sludge	Anammox	Shortcut N Removal	Bioaugmentation	Post Aerobic Digestion (PAD)	Ammonia Recovery Processes (Phys/Chem)	Nitrifying Fixed Film Processes	Denitrification Fixed Film Processes	Anammox Polishing Process	Algae Treatment	Encapsulation/Engineered Biomass	Membrane Bioreactor (MBR)	Integrated Fixed-Film Activated Sludge (IFAS)/ Moving Bed Biofilm Reactor (MBBR)	Ballasted Sedimentation (BioMag <sup>®</sup> )	Hybrid Fixed-Film/Ballast	Partial Granulation	Membrane Aerated Biofilm Reactor (MABR)	Chemically Enhanced Primary Treatment (CEPT)	Primary Filtration
Technology status <sup>2</sup>	3	3	3	Fail	2	3	3	3	2	Fail	3	3	Fail	1	Fail	3	3	2	2	2	2	3	3
Scalability to large WWTP	3	3	3	1	2	3	3	3	3	1	3	3	1	1	1	3	3	2	Fail	3	2	3	2
Effluent N concentration	2	3	3	1	3	1	1	1	1	1	1	3	1	3	3								
Load variation impact	2	2	2	1	2						2	3	1	2		2	2	2	2	2	2	3	3
Flow variation impact	2	2	2	1	1						2	2	1	2		1	1	3	3	2	2	3	2
Footprint <sup>3</sup>	1	1	1	1	3	3	2	2	1	2	1	2	2	1	3	3	2	3	2	2	2	3	3
Impacts to other processes <sup>4</sup>	3	3	3	2	1	3	3	3	3	2	3	3	3	3	3	2	2	2	2	3	2	1	2
Truck traffic	2	2	1	2	2	2	2	2	3	1	2	1	2	2	2	2	2	2	2	3	2	1	2
Energy use	2	2	3	3	3	3	2	2	1	1	1	1	3	2	2	1	1	2	2	3	2	3	3
GHG emissions	2	2	1	2	2	2	1	2	2	1	2	2	2	2	2	2	2	2	2	2	2	2	3
Resource recovery <sup>5</sup>	2	2	2	2	2	2	2	2	2	3	2	2	2	3	2	3	2	2	2	2	2	3	3
Capital cost <sup>6</sup>	2	2	2	2	1	2	2	3	1	1	1	2	2	1	1	1	2	1	2	3	1	2	1
O&M cost	3	2	3	3	3	3	2	2	2	1	1	1	3	2	2	1	1	2	2	2	2	1	2
Constructability	2	2	2	1	1	3	3	3	3	3	3	3	3	3	3	2	2	3	2	3	2	3	2
Operational complexity	3	3	2	1	2	2	1	3	2	1	3	2	1	2	2	2	2	2	2	3	1	3	2
<b>Overall</b>	<b>34</b>	<b>34</b>	<b>33</b>	<b>Fail</b>	<b>30</b>	<b>32</b>	<b>27</b>	<b>31</b>	<b>26</b>	<b>Fail</b>	<b>30</b>	<b>33</b>	<b>Fail</b>	<b>30</b>	<b>Fail</b>	<b>28</b>	<b>27</b>	<b>30</b>	<b>Fail</b>	<b>35</b>	<b>26</b>	<b>34</b>	<b>33</b>

Notes:

- Scale of 1 to 3, where 3 represents the greatest benefit or lowest cost, footprint, emissions, etc.
- Fail if the technology is not expected to be proven at full scale within the next five years, the technology presents too much risk, etc.
- Fail if it is clear that the technology will not be able to fit on the WWTP site.
- Fail if the technology will have unacceptable impacts to other plant processes or impacts that will be difficult to accommodate.

5. Resource recovery includes nutrient recovery (N or P), flexibility for future reclaimed water production (TN limits, filtration, etc.), energy recovery, etc. "1" indicates detrimental to resource recovery, "2" indicates no impact to potential for resource recovery, "3" indicates some benefit to resource recovery inherent in the technology.

6. Mainstream capital cost assumes additional tankage and no intensification. If intensification is added, this has the potential to decrease capital cost.

Screening Criteria <sup>1</sup>	Mainstream					Sidestream					Tertiary					Intensification						Carbon Diversion		
	Modified Ludzack-Ettinger (MLE)	Four-Stage Modified Bardenpho (4SMB)	Simultaneous Nitrification-Denitrification (SND)	Anammox	Aerobic Granular Sludge	Anammox	Shortcut N Removal	Bioaugmentation	Post Aerobic Digestion (PAD)	Ammonia Recovery Processes (Phys/Chem)	Nitrifying Fixed Film Processes	Denitrification Fixed Film Processes	Anammox Polishing Process	Algae Treatment	Encapsulation/Engineered Biomass	Membrane Bioreactor (MBR)	Integrated Fixed-Film Activated Sludge (IFAS)	Fixed Film	Ballasted Sedimentation (BioMag®)	Hybrid Fixed-Film/Ballast	Partial Granulation	Membrane Aerated Biofilm Reactor (MABR)	Chemically Enhanced Primary Treatment (CEPT)	Primary Filtration
Technology status <sup>2</sup>	3	3	3	Fail	2	3	3	3	2	Fail	3	3	Fail	1	Fail	3	3	3	2	2	2	2	3	3
Scalability to large WWTP	3	3	3	1	2	3	3	3	3	1	3	3	1	1	1	3	3	3	2	Fail	3	2	3	2
Effluent N concentration	2	3	3	1	3	1	1	1	1	1	1	3	1	3	3									
Load variation impact	2	2	2	1	2						2	3	1	2		2	2	2	2	2	2	2	3	3
Flow variation impact	2	2	2	1	1						2	2	1	2		1	1	1	3	3	2	2	3	2
Footprint <sup>3</sup>	1	1	1	1	3	3	2	2	1	2	1	2	2	Fail	3	3	2	2	3	2	2	2	3	3
Impacts to other processes <sup>4</sup>	3	3	3	2	1	3	3	3	3	2	3	3	3	3	3	2	2	2	2	2	3	2	1	2
Truck traffic	2	2	1	2	2	2	2	2	3	1	2	1	2	2	2	2	2	2	2	2		2	1	2
Energy use	2	2	3	3	3	3	2	2	1	1	1	1	3	2	2	1	1	2	2	2	3	2	3	3
GHG emissions	2	2	1	2	2	2	1	2	2	1	2	2	2	2	2	2	2	1	2	2	2	2	2	3
Resource recovery <sup>5</sup>	2	2	2	2	2	2	2	2	2	3	2	2	2	3	2	3	2	2	2	2	2	2	3	3
Capital cost <sup>6</sup>	2	2	2	2	1	2	2	3	1	1	1	2	2	1	1	1	2	1	1	2	3	1	2	1
O&M cost	3	2	3	3	3	3	2	2	2	1	1	1	3	2	2	1	1	2	2	2	2	2	1	2
Constructability	1	1	1	1	1	2	2	2	1	2	1	2	2	1	1	2	1	1	2	1	3	2	3	2
Operational complexity	3	3	2	1	2	2	1	3	2	1	3	2	1	2	2	2	2	2	2	3	1	3	2	
<b>Overall</b>	<b>33</b>	<b>33</b>	<b>32</b>	<b>Fail</b>	<b>30</b>	<b>31</b>	<b>26</b>	<b>30</b>	<b>24</b>	<b>Fail</b>	<b>28</b>	<b>32</b>	<b>Fail</b>	<b>Fail</b>	<b>Fail</b>	<b>28</b>	<b>26</b>	<b>26</b>	<b>29</b>	<b>Fail</b>	<b>32</b>	<b>26</b>	<b>34</b>	<b>33</b>

Notes:

1. Scale of 1 to 3, where 3 represents the greatest benefit or lowest cost, footprint, emissions, etc.

2. Fail if the technology is not expected to be proven at full scale within the next five years, the technology presents too much risk, etc.

3. Fail if it is clear that the technology will not be able to fit on the WWTP site.

4. Fail if the technology will have unacceptable impacts to other plant processes or impacts that will be difficult to accommodate.

5. Resource recovery includes nutrient recovery (N or P), flexibility for future reclaimed water production (TN limits, filtration, etc.), energy recovery, etc. "1" indicates detrimental to resource recovery, "2" indicates no impact to potential for resource recovery, "3" indicates some benefit to resource recovery inherent in the technology.

6. Mainstream capital cost assumes additional tankage and no intensification. If intensification is added, this has the potential to decrease capital cost.

## Appendix B: TM 2—West Point

---

This page intentionally left blank.



# Technical Memorandum

701 Pike Street, Suite 1200  
Seattle, WA 98101-2310

Phone: 206-624-0100  
Fax: 206-749-2200

Prepared for: King County

Project Title: King County Flows and Loads–Nitrogen Removal Study

Project No.: 151084.460

## Technical Memorandum 2

Subject: West Point Nitrogen Removal Technology Combinations  
Review and Screening

Date: June 25, 2019

To: Eron Jacobson, KC Nitrogen Removal Task Lead

From: Rick Kelly, BC Nitrogen Removal Task Lead

Prepared by:   
Matt Winkler, P.E., WA License. No. 52196, Expiration 3/4/2021

Reviewed by:   
Richard Kelly, Ph.D., P.E., WA License. No. 45235, Expiration 6/3/2021

*This document was prepared solely for King County in accordance with professional standards at the time the services were performed and in accordance with the contract between King County and Brown and Caldwell dated August 1, 2017. This document is governed by the specific scope of work authorized by King County; it is not intended to be relied upon by any other party except for regulatory authorities contemplated by the scope of work. We have relied on information or instructions provided by King County and other parties and, unless otherwise expressly indicated, have made no independent investigation as to the validity, completeness, or accuracy of such information.*



## Introduction

The purpose of this technical memorandum (TM) is to document the results of the nitrogen removal technology screening evaluation for the West Point Treatment Plant (West Point). The screening evaluation presented in this TM builds upon the results from the initial screening meeting for West Point, where a total of eight technologies were carried forward for more detailed screening. In contrast to the initial screening process, which ranked individual technologies by category, this final screening evaluation ranked combinations of the different technologies, referred to as technology combination alternatives. Brown and Caldwell (BC) developed preliminary rankings for the technology combination alternatives and conducted West Point Nitrogen Removal Workshop 1 with King County (County) staff on May 14, 2019. During the workshop, the County and BC discussed the alternatives, revised rankings, and selected technology combination alternatives for the four nitrogen removal scenarios for West Point. This TM summarizes the results of Workshop 1 and discusses next steps for the West Point nitrogen removal analysis.

## Section 1: Nitrogen Removal Scenarios

The County and BC participated in a conference call on April 24, 2019, to discuss and select up to four nitrogen removal effluent limits/modifications scenarios for each of the County's three large treatment facilities (West Point, South Treatment Plant, and Brightwater Treatment Plant). The following nitrogen removal scenarios were selected for West Point:

1. Sidestream treatment only
2. Year-round N removal, lowest effluent total inorganic nitrogen (TIN) possible while maintaining existing secondary treatment capacity
3. Seasonal N removal, lowest effluent TIN possible while maintaining existing secondary treatment capacity
4. Year-round N removal, effluent TIN limit of 8 mg/L (identify reduced secondary treatment capacity)

The scenarios are arranged in order of increasing overall nitrogen removal. Refer to the meeting notes in Attachment A for additional information. As discussed in the following sections, technology combination alternatives were evaluated and selected for each of the four nitrogen removal scenarios.

## Section 2: Overview of Technologies

This section provides background information on the technology categories and summarizes technologies remaining from the initial screening meeting for West Point. More detailed information on each of the individual technologies was presented in the *Nitrogen Removal Technologies Technical Summaries and Pre-Screening TM* (TM 1). This section also provides an overview of the Workshop 1 discussion related to the feasibility of converting West Point's existing high purity oxygen (HPO) process to a nitrogen removal configuration.

### 2.1 Technology Categories/Classifications

As described in TM 1, each technology was categorized by its implementation type or plant impacts. Five technology categories/classifications were developed, as summarized below.

- **Mainstream treatment:** Employed as the mainstream biological secondary treatment process and must be capable of nitrogen removal.



- **Sidestream treatment:** Implemented only on the plant biosolids and dewatering streams. They are capable of removing nitrogen in the biosolids/dewatering streams or used to nitrify these streams and seed nitrifiers back to the main process to allow for lower solids retention time (SRT) operation of the mainstream technologies.
- **Tertiary treatment:** Used for nitrification and nitrogen removal following the mainstream biological secondary treatment process.
- **Intensification:** Allows for operating the mainstream treatment process in a smaller footprint by allowing for a higher biomass concentration in the same footprint. They do not necessarily remove nitrogen on their own but are used in conjunction with a nitrogen removal mainstream or tertiary treatment process. The exception to this is the biological aerated filter (BAF) technology that has been classified as an intensification process, where BAF would treat primary effluent and serve as the mainstream secondary nitrogen removal process. As discussed in TM 1, BAF is being considered for West Point as an alternative to a membrane bioreactor (MBR) for intensification, assuming BAF could be operated in a single-stage mode using simultaneous nitrification/denitrification (SND).
- **Carbon diversion:** Removes excess biochemical oxygen demand from influent wastewater before secondary treatment, allowing for operating secondary treatment processes for nitrogen removal in a smaller footprint with less energy. These technologies also divert additional solids into digestion processes and can allow for additional biogas generation for resource recovery or reuse.

## 2.2 Technologies Remaining from Initial Screening

Table 1 summarizes the technologies remaining from the initial screening evaluation for West Point. For the final screening evaluation presented in this TM, alternatives were developed using either a single technology from one category or multiple technologies combined from various categories (Section 3.1).

<b>Technology</b>	<b>Classification</b>
Modified Ludzack-Ettinger	Mainstream
Four-stage Modified Bardenpho	Mainstream
Anammox	Sidestream
Bioaugmentation	Sidestream
Membrane bioreactor	Intensification
Partial granulation	Intensification
BAF/ fixed film	Intensification
Chemically-enhanced primary treatment	Carbon diversion

## 2.3 Modified HPO Process for Nitrogen Removal

The feasibility and pros and cons of converting West Point’s existing HPO process to a nitrogen removal configuration were discussed during Workshop 1 (refer to Attachment C for presentation slides). Figure 1 shows a schematic of a potential configuration for modifying the existing HPO process for nitrogen removal using a modified Ludzack-Ettinger (MLE) process (MLE-HPO). The main modifications that would be required to convert the existing HPO aeration basins to MLE-HPO were discussed during the workshop and are summarized below.

- To modify from conventional HPO to nitrogen removal, an anoxic stage is required (Stage 1). HPO gas would be input into Stage 2.



- Headspace gas would be vented from Stage 3 to decrease carbon dioxide (CO<sub>2</sub>) concentrations in the headspace of Stage 4 to allow the pH to recover. A small blower would also ventilate the headspace of Stage 4.
- Internal mixed liquor return (IMLR) pumps would need to be added, as well as oxygen dissolution capacity (replacement of existing mechanical aerators). IMLR could be implemented by pumping from the mixed liquor channel to the nearby intermediate pump station.

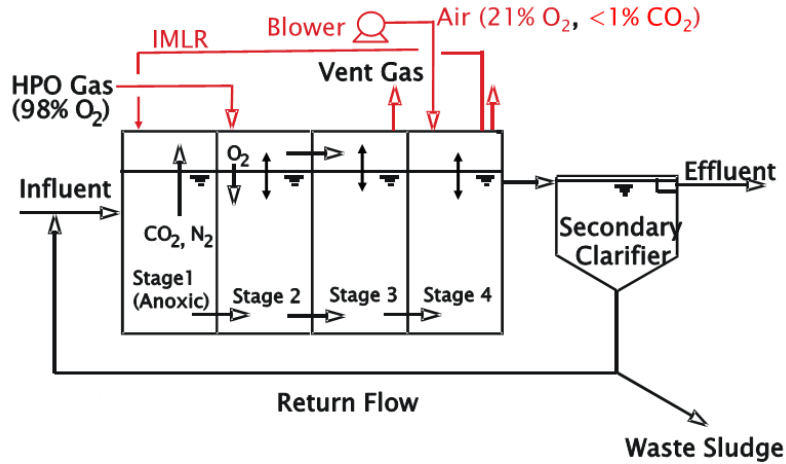

Figure 1. Schematic of HPO process modified for nitrogen removal (MLE-HPO)

Because of site footprint constraints at West Point, MLE-HPO is likely only a possible treatment alternative for seasonal nitrogen removal at a reduced capacity. The secondary treatment capacity will be reduced to operate at an SRT needed for full nitrification. In addition, because of pH depression and associated nitrification kinetic impacts at reduced pH, the required SRT for full nitrification will be higher for an MLE-HPO process compared to an MLE-CAS process (MLE with conventional activated sludge using diffused aeration). Therefore, MLE-HPO will require a greater footprint than MLE-CAS. MLE-CAS is also easier and less expensive to operate than MLE-HPO.

If MLE-HPO is operated at a lower SRT to reduce footprint requirements, partial nitrification could occur. Partial nitrification is hard to control and could cause nitrite lock, which increases hypochlorite demand for disinfection. It is difficult to operate in a partial nitrification mode even if nitrite lock does not occur. Partial nitrification is also difficult to model accurately.

Based on workshop discussion and disadvantages of MLE-HPO relative to MLE-CAS, a modified HPO process for nitrogen removal will not be carried forward in the study at this time. Therefore, any alternatives that use MLE or four-stage modified Bardenpho (4SMB) mainstream processes will be modeled and sized assuming that the HPO aeration basins are converted to conventional activated sludge with diffused aeration. MLE-HPO could be considered as a new scenario, as part of a later project, if MLE is found to be a viable alternative.

### Section 3: Technology Combinations Review and Screening

This section summarizes the screening evaluation conducted during Workshop 1. It includes a review of the technology combination alternatives, screening criteria and assigned weighting scores, application of screening criteria and assigned scores for technology combination alternatives, and overall results for each nitrogen removal scenario.

### 3.1 Technology Combinations

Although most of the individual technologies provide nitrogen removal as stand-alone processes (e.g., mainstream, sidestream, tertiary, or BAF as an intensification process), some nitrogen removal scenarios will require combinations of the various technologies from different categories to meet effluent nitrogen targets while satisfying other site constraints or objectives. Table 2 shows an example of how the technologies interact, or can be combined, to achieve various levels of nitrogen removal or effluent TIN concentrations.

Table 2. Example of Technology Combinations for Different Effluent TIN Targets		
TIN < 20 mg/L	TIN < 8 mg/L	TIN < 3 mg/L
Sidestream only (depending on influent nitrogen and nitrogen load in dewatering return streams)	Mainstream only	Mainstream + sidestream + tertiary
Mainstream only	Mainstream + sidestream	Tertiary only
Tertiary only		Tertiary + sidestream Mainstream + intensification + sidestream

For West Point, a total of 24 possible technology combination alternatives were developed for the screening evaluation. The technology combination alternatives are shown in the base technology combination matrix in Attachment B. However, for scenarios where a certain technology combination alternative was unable to meet the permit objectives, or was not viable, the alternative was failed and removed from consideration for that scenario. The following sections provide a brief overview of alternatives that were evaluated for each scenario. Refer to the tables in Attachment B for the full list of technology combination alternatives for each scenario and justification for failing certain alternatives. The screening matrices provided in Section 3.3, also show the failed alternatives for each scenario.

#### 3.1.1 Scenario 1: Sidestream Treatment Only

A screening evaluation was not required for Scenario 1. Of the two remaining sidestream treatment technologies, anammox and bioaugmentation, anammox is the only process that makes sense for operation as a stand-alone sidestream treatment process for West Point. Although bioaugmentation could be considered in a sidestream-only configuration, the bioaugmentation system would need to be configured for nitrification/denitrification instead of nitrification alone and would have higher operating costs and added complexity compared to an anammox system.

#### 3.1.2 Scenario 2: Year-round Nitrogen Removal at Existing Capacity

A total of ten alternatives were considered in the screening evaluation for Scenario 2. Alternatives that would not fit on the available site footprint, such as MLE or 4SMB without intensification, were failed. Alternatives with partial granulation were also failed because they would be unlikely to provide enough footprint reduction for year-round nitrogen removal without reducing capacity. Alternatives that included partial granulation in an MBR configuration were failed because of uncertainties and limited experience with partial granulation benefits for MBR operation. A complete list of the technology combination alternatives for Scenario 2 is shown in Figure 3 in Section 3.3 below.

#### 3.1.3 Scenario 3: Seasonal Nitrogen Removal at Existing Capacity

A total of 14 alternatives were considered in the screening evaluation for Scenario 3. Like Scenario 2, many alternatives were failed for site footprint considerations, but some additional alternatives were passed because Scenario 3 requires seasonal, instead of year-round, nitrogen removal. A complete list of the technology combination alternatives for Scenario 3 is presented in Figure 4 in Section 3.3 below.



### 3.1.4 Scenario 4: Year-round Nitrogen Removal (TIN = 8 mg/L) at Reduced Capacity

A total of 22 alternatives were considered in the screening evaluation for Scenario 4. Only the alternatives that included partial granulation with MBR were failed. A complete list of the technology combination alternatives for Scenario 4 is presented in Figure 5.

## 3.2 Screening Criteria and Weighting

BC developed preliminary screening criteria and assigned draft weighting scores that were reviewed with the County during Workshop 1. In general, the same screening criteria that were used for the initial screening evaluation (TM 1) were retained for this analysis. However, the criterion for “scalability to large WWTP” was removed because all technologies are scalable and would have the same ranking. Weighting scores were assigned on a 1 to 3 scale, where a score of 3 represents the greatest importance to the facility. The weighting score for each criterion is multiplied by the assigned score for that criterion for each alternative to calculate a total weighted score (Section 3.3).

Table 3 summarizes the final list of screening criteria and assigned weighting scores from Workshop 1.

Table 3. Screening Criteria and Assigned Weighting Scores for West Point		
Screening criteria	Weight <sup>a</sup>	Notes or adjustments from Workshop 1
Technology status	1	
Effluent nitrogen concentration	2	
Load variation impact	1	
Flow variation impact	2	
Footprint	3	
Impacts to other processes	2	
Truck traffic	1	Decreased weighting score from 3 to 1. In terms of biosolids truck traffic, the official limit is 13 while 5 is the target. However, the County may end up having to renegotiate the truck traffic limit in the future. It was decided that the weighting should be changed to 1 for this analysis.
Energy use	2	
Greenhouse gas (GHG) emissions	2	
Resource recovery	1	
Capital cost	1	Capital cost was assigned a low weighting score for this screening evaluation to avoid eliminating alternatives by cost alone, recognizing that alternatives with high capital cost may be the only feasible options for certain nitrogen removal scenarios. In addition, one of the County's objectives for this project is to determine costs of feasible options and have a range of capital costs for different nitrogen removal scenarios. Capital costs will be developed for selected alternatives as part of the life-cycle cost analysis in the next step of the project.
Operation & Maintenance (O&M) cost	1	O&M cost was assigned a low weighting score for similar reasons as the capital cost criterion. O&M costs will be developed for selected alternatives as part of the life-cycle cost analysis in the next step of the project.
Constructability	2	It was discussed during the workshop that all technologies are capable of being constructed, but at this point constructability is a very high-level criterion (pending actual sizing and site layouts).
Operational complexity	2	Increased weighting score from 1 to 2.

a. Score of 1 to 3, where 3 represents the highest weighting factor.

### 3.3 Application of Screening Criteria

The screening criteria were applied separately to each technology combination alternative. BC assigned draft scores for each criterion for each alternative before Workshop 1. Scores were adjusted based on workshop discussion. Notes from the workshop discussion are summarized below:

- In terms of technology status, there is some uncertainty associated with partial granulation in combination with MBR and with fixed film (BAF) operating with SND. There is limited experience for these technology combinations. Therefore, the technology status scores were reduced for these alternatives.
- A question was asked about how MBR capacity will be evaluated for MBR alternatives, given that the difference between manufacturer design capacity and observed capacity at Brightwater Treatment Plant has been significant and noticeable.
  - When sizing for the MBR alternatives, lower flux rates could be assumed, which results in more membranes and thus higher capital costs. The same mixed liquor suspended solids (MLSS) limit will be used so that there is less impact on aeration basin sizing.
  - The basis for MBR sizing will be confirmed during the next phase of the project.
- For operational complexity, the scores for partial granulation were reduced (typically dropping from 2s and 3s to 1s and 2s).
- It was noted that it is difficult to score constructability before developing sizing/layouts and a construction staging plan. This may become more understood in the planning level design and estimate.
- The capital cost score for alternative 13 was changed to a 1 (it was an error at a 2).
- For MBR alternatives, the secondary clarifiers could be maintained for seasonal N removal (Scenario 3). With year-round N removal, all clarifiers would be removed (Scenario 2).

The final scoring for each alternative is shown in the base technology combination screening matrix (Figure 2). The total weighted score for each alternative was used as the primary basis for identifying recommended alternatives to carry forward for each scenario, but alternatives with lower scores were still considered where it made sense. The final technology combination screening matrices for Scenarios 2, 3, and 4 are shown on Figure 3, Figure 4, and Figure 5, respectively. The matrices for Scenarios 2, 3, and 4 use the same scores as the base matrix, but show technologies that were failed for each scenario.

		Technology combination alternatives																							
		1	2	3	4	5	6	7	8	9	10	11	12	13	14	15	16	17	18	19	20	21	22	23	24
Technologies	Classification																								
MLE	Mainstream	✓	✓	✓	✓	✓	✓	✓	✓													✓	✓		
4SMB	Mainstream									✓	✓	✓	✓	✓	✓	✓	✓							✓	✓
Anammox	Sidestream			✓	✓	✓	✓					✓	✓	✓	✓					✓	✓	✓		✓	
Bioaugmentation	Sidestream								✓	✓						✓	✓						✓		✓
MBR	Intensification		✓	✓	✓	✓					✓	✓	✓	✓											
Fixed film	Intensification																		✓	✓	✓	✓			
Partial granulation	Intensification					✓	✓	✓	✓					✓	✓	✓	✓								
CEPT	Carbon diversion				✓				✓				✓				✓		✓		✓				
Screening criteria	Weight <sup>2</sup>	Score <sup>1</sup>																							
Technology status	1	5	5	5	5	2	3	3	3	5	5	5	5	2	3	3	3	2	2	2	2	5	5	5	5
Effluent N concentration	2	3	3	4	4	4	4	3	3	4	4	5	5	5	4	4	4	3	3	4	4	4	4	5	5
Load variation impact	1	3	3	3	4	3	3	3	4	3	3	3	4	3	3	3	4	3	4	3	4	3	3	3	3
Flow variation impact	2	3	1	1	2	2	4	4	5	3	1	1	2	2	4	4	5	1	2	1	2	3	3	3	3
Footprint	3	1	4	5	5	4	2	3	3	1	4	5	5	4	2	3	3	3	4	3	4	2	2	2	2
Impacts to other processes	2	5	3	3	1	3	4	4	1	5	3	3	1	3	4	4	1	2	1	2	1	5	5	5	5
Truck traffic	1	4	4	4	1	4	4	4	1	3	3	3	1	3	3	3	1	4	1	4	1	4	4	3	3
Energy use	2	4	1	2	2	2	4	3	3	4	1	2	2	2	4	3	3	2	2	3	3	5	4	5	4
GHG emissions	2	3	2	2	2	2	3	3	3	3	2	2	2	2	3	3	3	2	2	2	2	3	3	3	3
Resource recovery <sup>3</sup>	1	2	4	4	5	4	2	2	3	2	4	4	5	4	2	2	3	2	3	2	3	2	2	2	2
Capital cost	1	5	2	1	1	2	3	4	4	4	2	1	1	2	3	4	4	2	2	1	1	4	4	3	3
O&M cost	1	5	2	3	1	3	5	4	2	4	2	3	1	3	5	4	2	3	1	3	1	5	4	5	4
Constructability	2	4	3	3	2	4	4	3	3	4	3	3	2	4	4	3	3	1	1	1	1	4	4	4	4
Operational complexity	2	5	3	2	1	1	3	3	3	4	2	1	1	1	3	3	3	3	3	2	2	4	4	3	3
Total un-weighted score		52	40	42	36	40	48	46	41	49	39	41	37	40	47	46	42	33	31	33	31	53	51	51	49
Total weighted score		81	64	69	60	66	78	75	68	78	63	68	62	67	77	76	70	53	53	54	54	85	82	83	80
Selected?																									

Notes:

1. Score of 1 to 5, where 5 represents the greatest benefit or lowest cost, footprint, emissions, etc.

2. Score of 1 to 3, where 3 represents the highest weighting factor.

3. Resource recovery includes nutrient recovery (N or P), flexibility for future reclaimed water production (TN limits, filtration, etc.), energy recovery, etc. "1" indicates detrimental to resource recovery, "2" indicates no impact to potential for resource recovery, "3" indicates some benefit to resource recovery inherent in the technology.

Figure 2. Base technology combination screening matrix for West Point





		Technology combination alternatives																							
		1	2	3	4	5	6	7	8	9	10	11	12	13	14	15	16	17	18	19	20	21	22	23	24
Technologies	Classification																								
MLE	Mainstream	✓	✓	✓	✓	✓	✓	✓	✓													✓	✓		
4SMB	Mainstream									✓	✓	✓	✓	✓	✓	✓	✓							✓	✓
Anammox	Sidestream			✓	✓	✓	✓					✓	✓	✓	✓					✓	✓	✓		✓	
Bioaugmentation	Sidestream							✓	✓							✓	✓						✓		✓
MBR	Intensification		✓	✓	✓	✓					✓	✓	✓	✓											
Fixed film	Intensification																	✓	✓	✓	✓				
Partial granulation	Intensification					✓	✓	✓	✓					✓	✓	✓	✓								
CEPT	Carbon diversion				✓				✓				✓				✓		✓		✓				
Screening criteria	Weight <sup>2</sup>	Score <sup>1</sup>																							
Technology status	1		5	5	5						5	5	5						2	2	2	2			
Effluent N concentration	2		3	4	4						4	5	5						3	3	4	4			
Load variation impact	1		3	3	4						3	3	4						3	4	3	4			
Flow variation impact	2		1	1	2						1	1	2						1	2	1	2			
Footprint	3		4	5	5						4	5	5						3	4	3	4			
Impacts to other processes	2		3	3	1						3	3	1						2	1	2	1			
Truck traffic	1		4	4	1						3	3	1						4	1	4	1			
Energy use	2		1	2	2						1	2	2						2	2	3	3			
GHG emissions	2		2	2	2						2	2	2						2	2	2	2			
Resource recovery <sup>3</sup>	1		4	4	5						4	4	5						2	3	2	3			
Capital cost	1		2	1	1						2	1	1						2	2	1	1			
O&M cost	1		2	3	1						2	3	1						3	1	3	1			
Constructability	2		3	3	2						3	3	2						1	1	1	1			
Operational complexity	2		3	2	1						2	1	1						3	3	2	2			
Total un-weighted score		Fail	40	42	36	Fail	Fail	Fail	Fail	Fail	39	41	37	Fail	Fail	Fail	Fail	33	31	33	31	Fail	Fail	Fail	Fail
Total weighted score		Fail	64	69	60	Fail	Fail	Fail	Fail	Fail	63	68	62	Fail	Fail	Fail	Fail	53	53	54	54	Fail	Fail	Fail	Fail
Selected?		No	Yes	Yes	No	No	No	No	No	No	No	Yes	No	No	No	No	No	No	No	No	No	No	No	No	No

Notes:

- Score of 1 to 5, where 5 represents the greatest benefit or lowest cost, footprint, emissions, etc.
- Score of 1 to 3, where 3 represents the highest weighting factor.
- Resource recovery includes nutrient recovery (N or P), flexibility for future reclaimed water production (TN limits, filtration, etc.), energy recovery, etc. "1" indicates detrimental to resource recovery, "2" indicates no impact to potential for resource recovery, "3" indicates some benefit to resource recovery inherent in the technology.

Figure 3. Technology combination screening matrix for West Point Scenario 2 (Year-round nitrogen removal at existing capacity)





		Technology combination alternatives																							
		1	2	3	4	5	6	7	8	9	10	11	12	13	14	15	16	17	18	19	20	21	22	23	24
Technologies	Classification																								
MLE	Mainstream	✓	✓	✓	✓	✓	✓	✓	✓													✓	✓		
4SMB	Mainstream									✓	✓	✓	✓	✓	✓	✓	✓							✓	✓
Anammox	Sidestream			✓	✓	✓	✓					✓	✓	✓	✓					✓	✓	✓		✓	
Bioaugmentation	Sidestream							✓	✓							✓	✓						✓		✓
MBR	Intensification		✓	✓	✓	✓					✓	✓	✓	✓											
Fixed film	Intensification																	✓	✓	✓	✓				
Partial granulation	Intensification					✓	✓	✓	✓					✓	✓	✓	✓								
CEPT	Carbon diversion				✓				✓				✓				✓		✓		✓				
Screening criteria	Weight <sup>2</sup>	Score <sup>1</sup>																							
Technology status	1		5	5	5			3	3		5	5	5			3	3	2	2	2	2				
Effluent N concentration	2		3	4	4			3	3		4	5	5			4	4	3	3	4	4				
Load variation impact	1		3	3	4			3	4		3	3	4			3	4	3	4	3	4				
Flow variation impact	2		1	1	2			4	5		1	1	2			4	5	1	2	1	2				
Footprint	3		4	5	5			3	3		4	5	5			3	3	3	4	3	4				
Impacts to other processes	2		3	3	1			4	1		3	3	1			4	1	2	1	2	1				
Truck traffic	1		4	4	1			4	1		3	3	1			3	1	4	1	4	1				
Energy use	2		1	2	2			3	3		1	2	2			3	3	2	2	3	3				
GHG emissions	2		2	2	2			3	3		2	2	2			3	3	2	2	2	2				
Resource recovery <sup>3</sup>	1		4	4	5			2	3		4	4	5			2	3	2	3	2	3				
Capital cost	1		2	1	1			4	4		2	1	1			4	4	2	2	1	1				
O&M cost	1		2	3	1			4	2		2	3	1			4	2	3	1	3	1				
Constructability	2		3	3	2			3	3		3	3	2			3	3	1	1	1	1				
Operational complexity	2		3	2	1			3	3		2	1	1			3	3	3	3	2	2				
<b>Total un-weighted score</b>		<b>Fail</b>	<b>40</b>	<b>42</b>	<b>36</b>	<b>Fail</b>	<b>Fail</b>	<b>46</b>	<b>41</b>	<b>Fail</b>	<b>39</b>	<b>41</b>	<b>37</b>	<b>Fail</b>	<b>Fail</b>	<b>46</b>	<b>42</b>	<b>33</b>	<b>31</b>	<b>33</b>	<b>31</b>	<b>Fail</b>	<b>Fail</b>	<b>Fail</b>	<b>Fail</b>
<b>Total weighted score</b>		<b>Fail</b>	<b>64</b>	<b>69</b>	<b>60</b>	<b>Fail</b>	<b>Fail</b>	<b>75</b>	<b>68</b>	<b>Fail</b>	<b>63</b>	<b>68</b>	<b>62</b>	<b>Fail</b>	<b>Fail</b>	<b>76</b>	<b>70</b>	<b>53</b>	<b>53</b>	<b>54</b>	<b>54</b>	<b>Fail</b>	<b>Fail</b>	<b>Fail</b>	<b>Fail</b>
<b>Selected?</b>		<b>No</b>	<b>No</b>	<b>Yes</b>	<b>No</b>	<b>No</b>	<b>No</b>	<b>Yes</b>	<b>No</b>	<b>No</b>	<b>No</b>	<b>No</b>	<b>No</b>	<b>No</b>	<b>No</b>	<b>Yes</b>	<b>No</b>	<b>No</b>	<b>No</b>	<b>No</b>	<b>No</b>	<b>No</b>	<b>No</b>	<b>No</b>	<b>No</b>

Notes:  
 1. Score of 1 to 5, where 5 represents the greatest benefit or lowest cost, footprint, emissions, etc.  
 2. Score of 1 to 3, where 3 represents the highest weighting factor.  
 3. Resource recovery includes nutrient recovery (N or P), flexibility for future reclaimed water production (TN limits, filtration, etc.), energy recovery, etc. "1" indicates detrimental to resource recovery, "2" indicates no impact to potential for resource recovery, "3" indicates some benefit to resource recovery inherent in the technology.

Figure 4. Technology combination screening matrix for West Point Scenario 3 (Seasonal nitrogen removal at existing capacity)



		Technology combination alternatives																							
		1	2	3	4	5	6	7	8	9	10	11	12	13	14	15	16	17	18	19	20	21	22	23	24
Technologies	Classification																								
MLE	Mainstream	✓	✓	✓	✓	✓	✓	✓	✓													✓	✓		
4SMB	Mainstream									✓	✓	✓	✓	✓	✓	✓	✓							✓	✓
Anammox	Sidestream			✓	✓	✓	✓					✓	✓	✓	✓					✓	✓	✓		✓	
Bioaugmentation	Sidestream							✓	✓							✓	✓						✓		✓
MBR	Intensification		✓	✓	✓	✓					✓	✓	✓	✓											
Fixed film	Intensification																	✓	✓	✓	✓				
Partial granulation	Intensification					✓	✓	✓	✓					✓	✓	✓	✓								
CEPT	Carbon diversion				✓				✓				✓				✓		✓		✓				
Screening criteria	Weight <sup>2</sup>	Score <sup>1</sup>																							
Technology status	1	5	5	5	5		3	3	3	5	5	5	5		3	3	3	2	2	2	2	5	5	5	5
Effluent N concentration	2	3	3	4	4		4	3	3	4	4	5	5		4	4	4	3	3	4	4	4	4	5	5
Load variation impact	1	3	3	3	4		3	3	4	3	3	3	4		3	3	4	3	4	3	4	3	3	3	3
Flow variation impact	2	3	1	1	2		4	4	5	3	1	1	2		4	4	5	1	2	1	2	3	3	3	3
Footprint	3	1	4	5	5		2	3	3	1	4	5	5		2	3	3	3	4	3	4	2	2	2	2
Impacts to other processes	2	5	3	3	1		4	4	1	5	3	3	1		4	4	1	2	1	2	1	5	5	5	5
Truck traffic	1	4	4	4	1		4	4	1	3	3	3	1		3	3	1	4	1	4	1	4	4	3	3
Energy use	2	4	1	2	2		4	3	3	4	1	2	2		4	3	3	2	2	3	3	5	4	5	4
GHG emissions	2	3	2	2	2		3	3	3	3	2	2	2		3	3	3	2	2	2	2	3	3	3	3
Resource recovery <sup>3</sup>	1	2	4	4	5		2	2	3	2	4	4	5		2	2	3	2	3	2	3	2	2	2	2
Capital cost	1	5	2	1	1		3	4	4	4	2	1	1		3	4	4	2	2	1	1	4	4	3	3
O&M cost	1	5	2	3	1		5	4	2	4	2	3	1		5	4	2	3	1	3	1	5	4	5	4
Constructability	2	4	3	3	2		4	3	3	4	3	3	2		4	3	3	1	1	1	1	4	4	4	4
Operational complexity	2	5	3	2	1		3	3	3	4	2	1	1		3	3	3	3	3	2	2	4	4	3	3
<b>Total un-weighted score</b>		<b>52</b>	<b>40</b>	<b>42</b>	<b>36</b>	<b>Fail</b>	<b>48</b>	<b>46</b>	<b>41</b>	<b>49</b>	<b>39</b>	<b>41</b>	<b>37</b>	<b>Fail</b>	<b>47</b>	<b>46</b>	<b>42</b>	<b>33</b>	<b>31</b>	<b>33</b>	<b>31</b>	<b>53</b>	<b>51</b>	<b>51</b>	<b>49</b>
<b>Total weighted score</b>		<b>81</b>	<b>64</b>	<b>69</b>	<b>60</b>	<b>Fail</b>	<b>78</b>	<b>75</b>	<b>68</b>	<b>78</b>	<b>63</b>	<b>68</b>	<b>62</b>	<b>Fail</b>	<b>77</b>	<b>76</b>	<b>70</b>	<b>53</b>	<b>53</b>	<b>54</b>	<b>54</b>	<b>85</b>	<b>82</b>	<b>83</b>	<b>80</b>
<b>Selected?</b>		<b>Yes</b>	<b>No</b>	<b>No</b>	<b>No</b>	<b>No</b>	<b>No</b>	<b>No</b>	<b>No</b>	<b>No</b>	<b>No</b>	<b>No</b>	<b>No</b>	<b>No</b>	<b>No</b>	<b>No</b>	<b>No</b>	<b>No</b>	<b>No</b>	<b>No</b>	<b>No</b>	<b>Yes</b>	<b>Yes</b>	<b>Yes</b>	<b>Yes</b>

Notes:

1. Score of 1 to 5, where 5 represents the greatest benefit or lowest cost, footprint, emissions, etc.

2. Score of 1 to 3, where 3 represents the highest weighting factor.

3. Resource recovery includes nutrient recovery (N or P), flexibility for future reclaimed water production (TN limits, filtration, etc.), energy recovery, etc. "1" indicates detrimental to resource recovery, "2" indicates no impact to potential for resource recovery, "3" indicates some benefit to resource recovery inherent in the technology.

Figure 5. Technology combination screening matrix for West Point Scenario 4 (Year-round nitrogen removal (TIN = 8 mg/L) at reduced capacity)



### 3.4 Results of Screening Evaluation

This section summarizes the results of the screening evaluation for each scenario.

#### 3.4.1 Scenario 1: Sidestream Treatment Only

Sidestream anammox was selected without a full screening, as it was the only viable option for evaluation (see discussion in Section 3.1.1).

#### 3.4.2 Scenario 2: Year-round Nitrogen Removal at Existing Capacity

Table 4 shows the total weighted scores from the workshop and selected alternatives for Scenario 2. The MLE/MBR and 4SMB/MBR alternatives, with and without sidestream anammox, scored highest. The top three alternatives, all of which include MBR for intensification, were selected for detailed evaluation.

Alternative	Description	Total weighted score	Selected?
3	MLE/MBR + sidestream anammox	69	Yes
11	4SMB/MBR + sidestream anammox	68	Yes
2	MLE/MBR	64	Yes
10	4SMB/MBR	63	No
12	4SMB/MBR + CEPT + sidestream anammox	62	No
4	MLE/MBR + CEPT + sidestream anammox	60	No
19	BAF + sidestream anammox	54	No
20	BAF + CEPT + sidestream anammox	54	No
17	BAF	53	No
18	BAF + CEPT	53	No

a. Alternatives are sorted by highest total weighted score. Failed alternatives are not shown.

#### 3.4.3 Scenario 3: Seasonal Nitrogen Removal at Existing Capacity

Table 5 shows the total weighted scores from the workshop and selected alternatives for Scenario 3. In general, MLE and 4SMB alternatives with partial granulation and sidestream bioaugmentation scored highest. The sizing and operational impacts/assumptions for a partial granulation system in MLE and 4SMB modes will need to be coordinated with vendors during the sizing and modeling steps. The potential footprint savings with sidestream bioaugmentation will also need to be evaluated during modeling, but it is expected to offer some benefit for seasonal nitrogen removal during the shoulder season (i.e., April), when West Point still has low influent wastewater temperatures and potential for high flow events. Instead of selecting three alternatives with partial granulation and sidestream bioaugmentation, MLE/MBR with sidestream anammox was selected as the third alternative for Scenario 3 to provide a range of mainstream options for evaluation.

Alternative	Description	Total weighted score	Selected?
15	4SMB + partial granulation + sidestream bioaugmentation	76	Yes
7	MLE + partial granulation + sidestream bioaugmentation	75	Yes
16	4SMB + partial granulation + CEPT + sidestream bioaugmentation	70	No
3	MLE/MBR + sidestream anammox	69	Yes
8	MLE + partial granulation + CEPT + sidestream bioaugmentation	68	No

Alternative	Description	Total weighted score	Selected?
11	4SMB/MBR + sidestream anammox	68	No
2	MLE/MBR	64	No
10	4SMB/MBR	63	No
12	4SMB/MBR + CEPT + sidestream anammox	62	No
4	MLE/MBR + CEPT + sidestream anammox	60	No
19	BAF + sidestream anammox	54	No
20	BAF + CEPT + sidestream anammox	54	No
17	BAF	53	No
18	BAF + CEPT	53	No

a. Alternatives are sorted by highest total weighted score. Failed alternatives are not shown.

### 3.4.4 Scenario 4: Year-round Nitrogen Removal (TIN = 8 mg/L) at Reduced Capacity

Table 6 shows the total weighted scores and selected alternatives for Scenario 4. The five alternatives with the highest scores were selected for detailed evaluation. MLE and 4SMB will both be evaluated, with either sidestream anammox or sidestream bioaugmentation, to compare benefits of sidestream treatment. As none of the selected alternatives include intensification, it is likely that all the selected alternatives will result in a significantly reduced capacity for West Point, which would require the County to treat the flows/loads above West Point's capacity at another location. Options and costs for treatment at alternate locations for a reduced capacity scenario at West Point are beyond the scope of this project.

Alternative	Description	Total weighted score	Selected?
21	MLE + sidestream anammox	85	Yes
23	4SMB + sidestream anammox	83	Yes
22	MLE + sidestream bioaugmentation	82	Yes
1	MLE	81	Yes
24	4SMB + sidestream bioaugmentation	80	Yes
6	MLE + partial granulation + sidestream anammox	78	No
9	4SMB	78	No
14	4SMB + partial granulation + sidestream anammox	77	No
15	4SMB + partial granulation + sidestream bioaugmentation	76	No
7	MLE + partial granulation + sidestream bioaugmentation	75	No
16	4SMB + partial granulation + CEPT + sidestream bioaugmentation	70	No
3	MLE/MBR + sidestream anammox	69	No
8	MLE + partial granulation + CEPT + sidestream bioaugmentation	68	No
11	4SMB/MBR + sidestream anammox	68	No
2	MLE/MBR	64	No
10	4SMB/MBR	63	No
12	4SMB/MBR + CEPT + sidestream anammox	62	No
4	MLE/MBR + CEPT + sidestream anammox	60	No

Table 6. Results of Screening Evaluation for West Point Scenario 4 <sup>a</sup>			
Alternative	Description	Total weighted score	Selected?
19	BAF + sidestream anammox	54	No
20	BAF + CEPT + sidestream anammox	54	No
17	BAF	53	No
18	BAF + CEPT	53	No

a. Alternatives are sorted by highest total weighted score. Failed alternatives are not shown.

### 3.5 Summary of Selected Alternatives

Table 7 summarizes the selected alternatives for each scenario and identifies the alternative numbering that will be used during the next phase of the project (e.g., Alternatives 1, 2A, 2B, etc.).

Table 7. Summary of Selected Alternatives for West Point Nitrogen Removal Scenarios	
Alternative	Description
Scenario 1: Sidestream treatment only	
1	Existing mainstream + sidestream anammox
Scenario 2: Year-round N removal, lowest effluent TIN possible while maintaining existing secondary treatment capacity	
2A	MLE/MBR
2B	MLE/MBR + sidestream anammox
2C	4SMB/MBR + sidestream anammox
Scenario 3: Seasonal N removal, lowest effluent TIN possible while maintaining existing secondary treatment capacity	
3A	MLE/MBR + sidestream anammox
3B	MLE + partial granulation + sidestream bioaugmentation
3C	4SMB + partial granulation + sidestream bioaugmentation
Scenario 4: Year-round N removal, effluent TIN limit of 8 mg/L (identify reduced secondary treatment capacity)	
4A	MLE
4B	MLE + sidestream anammox
4C	MLE + sidestream bioaugmentation
4D	4SMB + sidestream anammox
4E	4SMB + sidestream bioaugmentation

## Section 4: Next Steps

The selected alternatives for West Point will be modeled and sized. The preliminary modeling results will be reviewed with the County before developing layouts, costs, and GHG emissions estimates. BC recommends scheduling a modeling review meeting/conference call for late July 2019.

## **Attachment A: Meeting Notes from Nitrogen Effluent Limit Conference Call**

---

# Meeting Notes

**Prepared for:** King County Wastewater Treatment Division

**Project Title:** Nitrogen (N) Removal Analysis

**Contract No.:** 1170-17 VLN

**Meeting Name:** Nitrogen Effluent Limit Discussion Conference Call

**Meeting Location:** Brightwater, Little Bear Creek Conference Room; South Plant, Black River Conference Room; West Point, Mt. Rainier Conference Room (or Skype)

**Meeting Date:** April 24, 2019

**Meeting Time:** 10:00 am to 11:30 am

**Purpose:** Discuss and select up to four effluent nitrogen conditions for each plant to be used as the basis for evaluation.

Invitees:	<u>Consultant Team:</u>	<u>King County:</u>	
	Rick Kelly (BC) Matt Winkler (BC) Patricia Tam (BC)	Eron Jacobson Tiffany Knapp John Conway Matthew Nolan Rick Butler Bob Bucher Eugene Sugita Jessica Tanumihardja Al Williamson Mike Wohlfert Jacque Klug Sally Gordon Tushar Khurana Jeff Lafer Robert Edsforth	Andy Strehler Carol Nelson Bob Bucher Karla Guevarra <del>Rebecca Gauff</del> Bruce Nairn Truong Phuong Tom Bauer Curtis Steinke Jeff Fugier Scott Drennen Steve Huang <del>Henry Campbell</del> Sue Meyer Carl Grodnik

## Notes

---

- Considerations for selecting four conditions at each plant:
  - Create a range of removal levels to help develop cost curves
  - Develop most cost effective options at each plant
  - Identify limits for each plant where costs increase significantly
  - Include likely concentrations limits as demonstrated by DoE's Bounding Scenarios (especially lowest limit(s))
  - Develop a range of removal levels for each plant to have data to support bubble/umbrella permit scenarios
  - Consider cap mentioned in DoE AKART response
- West Point Limits / Modifications
  1. Side stream treatment, year round (assuming it can fit on site)
  2. Lowest removal level possible, year-round, maintaining existing plant capacity
  3. Lowest removal level possible, seasonal, maintaining same plant capacity
  4. 8 mg/L, year-round, identify the reduced capacity of the plant
  - Notes:

- For #4, may need to consider changes to permitting and West Point operations, depending on the secondary capacity remaining at the plant with the proposed additions of nutrient removal
- It was noted that the significant amount of snowmelt this year led to abnormally low influent temperature at West Point (less than 8-9 deg C). This will need to be incorporated into the evaluation for winter scenarios.
- South Plant Limits / Modifications
  1. Side stream treatment, year round, nitrification/de-nitrification during summer with existing infrastructure
  2. 3 mg/L, year-round
  3. 8 mg/L equivalent, year-round, most cost-effective approach (e.g. 5 mg/L summer and 12 mg/L winter)
  4. 8 mg/L, seasonally
  - Notes:
    - Potential to switch between N removal in summer and bio-P in winter, similar to current operation when nitrifying in summer
    - The option to try to maximize N removal with existing basins (i.e. relocate baffles, add IMLR pumps, and/or add carbon addition) was deemed to provide less information that determining the optimal configuration to achieve a given concentration. A review of necessary modifications to existing tanks and other infrastructure could then be evaluated to meet the optimal configuration.
- Brightwater Limits / Modifications
  1. 3 mg/L, year-round
  2. 8 mg/L equivalent, year-round, most cost-effective approach (e.g. 5 mg/L summer and 12 mg/L winter)
  3. Side-stream treatment with Brightwater Aeration Basin Optimization (BWABO) upgrades assumed to be complete including Simultaneous Nitrification Denitrification (SND)
  4. Left open for now
  - Notes:
    - Nitrogen removal from SND needs to be modeled in greater detail. Performance is uncertain because of the differences compared to other operating SND facilities (lower temperatures, membrane application, etc.)
    - While BW could potentially take more flow, from SP for example, and potentially remove more N more cost effectively, this analysis goes beyond the scope of the project. Ultimately, this configuration should be considered once permit requirements are better understood (along with other flow redistribution configurations).
    - Brightwater has planned expansion for Aeration Basin #4. Consider the expansion when developing various technologies and the associated removal limits and strategies.



## **Attachment B: Technology Combinations**

---



Base technology combination matrix											
Technology combination alternatives	Description	Mainstream		Sidestream		Intensification			Carbon diversion	Pass/Fail	Justification for failure
		MLE	4SMB	Anammox	Bioaugmentation	MBR	Fixed film	Partial granulation	CEPT		
1	MLE	✓									
2	MLE/MBR	✓				✓					
3	MLE/MBR + sidestream anammox	✓		✓		✓					
4	MLE/MBR + CEPT + sidestream anammox	✓		✓		✓			✓		
5	MLE/MBR + partial granulation + sidestream anammox	✓		✓		✓		✓			
6	MLE + partial granulation + sidestream anammox	✓		✓				✓			
7	MLE + partial granulation + sidestream bioaugmentation	✓			✓			✓			
8	MLE + partial granulation + CEPT + sidestream bioaugmentation	✓			✓			✓	✓		
9	4SMB		✓								
10	4SMB/MBR		✓			✓					
11	4SMB/MBR + sidestream anammox		✓	✓		✓					
12	4SMB/MBR + CEPT + sidestream anammox		✓	✓		✓			✓		
13	4SMB/MBR + partial granulation + sidestream anammox		✓	✓		✓		✓			
14	4SMB + partial granulation + sidestream anammox		✓	✓				✓			
15	4SMB + partial granulation + sidestream bioaugmentation		✓		✓			✓			
16	4SMB + partial granulation + CEPT + sidestream bioaugmentation		✓		✓			✓	✓		
17	BAF						✓				
18	BAF + CEPT						✓		✓		
19	BAF + sidestream anammox			✓			✓				
20	BAF + CEPT + sidestream anammox			✓			✓		✓		
21	MLE + sidestream anammox	✓		✓							
22	MLE + sidestream bioaugmentation	✓			✓						
23	4SMB + sidestream anammox		✓	✓							
24	4SMB + sidestream bioaugmentation		✓		✓						

Scenario 2: Year-round N removal, lowest effluent TIN possible while maintaining existing secondary treatment capacity											
Technology combination alternatives	Description	Mainstream		Sidestream		Intensification			Carbon diversion	Pass/Fail	Justification for failure
		MLE	4SMB	Anammox	Bioaugmentation	MBR	Fixed film	Partial granulation	CEPT		
1	MLE	✓								Fail	Insufficient site footprint for MLE alone (without reducing capacity)
2	MLE/MBR	✓				✓				Pass	
3	MLE/MBR + sidestream anammox	✓		✓		✓				Pass	
4	MLE/MBR + CEPT + sidestream anammox	✓		✓		✓			✓	Pass	
5	MLE/MBR + partial granulation + sidestream anammox	✓		✓		✓		✓		Fail	Limited experience with partial granulation in MBR configuration.
6	MLE + partial granulation + sidestream anammox	✓		✓				✓		Fail	Partial granulation unlikely to provide sufficient footprint reduction for year-round N removal (without reducing capacity).
7	MLE + partial granulation + sidestream bioaugmentation	✓			✓			✓		Fail	Partial granulation unlikely to provide sufficient footprint reduction for year-round N removal (without reducing capacity).
8	MLE + partial granulation + CEPT + sidestream bioaugmentation	✓			✓			✓	✓	Fail	Partial granulation unlikely to provide sufficient footprint reduction for year-round N removal (without reducing capacity).
9	4SMB		✓							Fail	Insufficient site footprint for 4SMB alone (without reducing capacity)
10	4SMB/MBR		✓			✓				Pass	
11	4SMB/MBR + sidestream anammox		✓	✓		✓				Pass	
12	4SMB/MBR + CEPT + sidestream anammox		✓	✓		✓			✓	Pass	
13	4SMB/MBR + partial granulation + sidestream anammox		✓	✓		✓		✓		Fail	Limited experience with partial granulation in MBR configuration.
14	4SMB + partial granulation + sidestream anammox		✓	✓				✓		Fail	Partial granulation unlikely to provide sufficient footprint reduction for year-round N removal (without reducing capacity).
15	4SMB + partial granulation + sidestream bioaugmentation		✓		✓			✓		Fail	Partial granulation unlikely to provide sufficient footprint reduction for year-round N removal (without reducing capacity).
16	4SMB + partial granulation + CEPT + sidestream bioaugmentation		✓		✓			✓	✓	Fail	Partial granulation unlikely to provide sufficient footprint reduction for year-round N removal (without reducing capacity).
17	BAF						✓			Pass	
18	BAF + CEPT						✓		✓	Pass	
19	BAF + sidestream anammox			✓			✓			Pass	
20	BAF + CEPT + sidestream anammox			✓			✓		✓	Pass	
21	MLE + sidestream anammox	✓		✓						Fail	Insufficient site footprint for without reducing capacity.
22	MLE + sidestream bioaugmentation	✓			✓					Fail	Insufficient site footprint for without reducing capacity.
23	4SMB + sidestream anammox		✓	✓						Fail	Insufficient site footprint for without reducing capacity.
24	4SMB + sidestream bioaugmentation		✓		✓					Fail	Insufficient site footprint for without reducing capacity.

Scenario 3: Seasonal N removal, lowest effluent TIN possible while maintaining existing secondary treatment capacity											
Technology combination alternatives	Description	Mainstream		Sidestream		Intensification			Carbon diversion	Pass/Fail	Justification for failure
		MLE	4SMB	Anammox	Bioaugmentation	MBR	Fixed film	Partial granulation	CEPT		
1	MLE	✓								Fail	Insufficient site footprint for MLE alone (without reducing capacity)
2	MLE/MBR	✓				✓				Pass	
3	MLE/MBR + sidestream anammox	✓		✓		✓				Pass	
4	MLE/MBR + CEPT + sidestream anammox	✓		✓		✓			✓	Pass	
5	MLE/MBR + partial granulation + sidestream anammox	✓		✓		✓		✓		Fail	Limited experience with partial granulation in MBR configuration.
6	MLE + partial granulation + sidestream anammox	✓		✓				✓		Fail	Partial granulation unlikely to provide sufficient footprint reduction (without reducing capacity).
7	MLE + partial granulation + sidestream bioaugmentation	✓			✓			✓		Pass	
8	MLE + partial granulation + CEPT + sidestream bioaugmentation	✓			✓			✓	✓	Pass	
9	4SMB		✓							Fail	Insufficient site footprint for 4SMB alone (without reducing capacity)
10	4SMB/MBR		✓			✓				Pass	
11	4SMB/MBR + sidestream anammox		✓	✓		✓				Pass	
12	4SMB/MBR + CEPT + sidestream anammox		✓	✓		✓			✓	Pass	
13	4SMB/MBR + partial granulation + sidestream anammox		✓	✓		✓		✓		Fail	Limited experience with partial granulation in MBR configuration.
14	4SMB + partial granulation + sidestream anammox		✓	✓				✓		Fail	Partial granulation unlikely to provide sufficient footprint reduction (without reducing capacity).
15	4SMB + partial granulation + sidestream bioaugmentation		✓		✓			✓		Pass	
16	4SMB + partial granulation + CEPT + sidestream bioaugmentation		✓		✓			✓	✓	Pass	
17	BAF						✓			Pass	
18	BAF + CEPT						✓		✓	Pass	
19	BAF + sidestream anammox			✓			✓			Pass	
20	BAF + CEPT + sidestream anammox			✓			✓		✓	Pass	
21	MLE + sidestream anammox	✓		✓						Fail	Insufficient site footprint for without reducing capacity.
22	MLE + sidestream bioaugmentation	✓			✓					Fail	Insufficient site footprint for without reducing capacity.
23	4SMB + sidestream anammox		✓	✓						Fail	Insufficient site footprint for without reducing capacity.
24	4SMB + sidestream bioaugmentation		✓		✓					Fail	Insufficient site footprint for without reducing capacity.

**Scenario 4: Year-round N removal, effluent TIN limit of 8 mg/L (identify reduced secondary treatment capacity)**

Technology combination alternatives	Description	Mainstream		Sidestream		Intensification			Carbon diversion	Pass/Fail	Justification for failure
		MLE	4SMB	Anammox	Bioaugmentation	MBR	Fixed film	Partial granulation	CEPT		
1	MLE	✓								Pass	
2	MLE/MBR	✓				✓				Pass	
3	MLE/MBR + sidestream anammox	✓		✓		✓				Pass	
4	MLE/MBR + CEPT + sidestream anammox	✓		✓		✓			✓	Pass	
5	MLE/MBR + partial granulation + sidestream anammox	✓		✓		✓		✓		Fail	Limited experience with partial granulation in MBR configuration.
6	MLE + partial granulation + sidestream anammox	✓		✓				✓		Pass	
7	MLE + partial granulation + sidestream bioaugmentation	✓			✓			✓		Pass	
8	MLE + partial granulation + CEPT + sidestream bioaugmentation	✓			✓			✓	✓	Pass	
9	4SMB		✓							Pass	
10	4SMB/MBR		✓			✓				Pass	
11	4SMB/MBR + sidestream anammox		✓	✓		✓				Pass	
12	4SMB/MBR + CEPT + sidestream anammox		✓	✓		✓			✓	Pass	
13	4SMB/MBR + partial granulation + sidestream anammox		✓	✓		✓		✓		Fail	Limited experience with partial granulation in MBR configuration.
14	4SMB + partial granulation + sidestream anammox		✓	✓				✓		Pass	
15	4SMB + partial granulation + sidestream bioaugmentation		✓		✓			✓		Pass	
16	4SMB + partial granulation + CEPT + sidestream bioaugmentation		✓		✓			✓	✓	Pass	
17	BAF						✓			Pass	
18	BAF + CEPT						✓		✓	Pass	
19	BAF + sidestream anammox			✓			✓			Pass	
20	BAF + CEPT + sidestream anammox			✓			✓		✓	Pass	
21	MLE + sidestream anammox	✓		✓						Pass	
22	MLE + sidestream bioaugmentation	✓			✓					Pass	
23	4SMB + sidestream anammox		✓	✓						Pass	
24	4SMB + sidestream bioaugmentation		✓		✓					Pass	

## **Attachment C: West Point Modified HPO Process Workshop 1 Slides**

---



# Current HPO Process

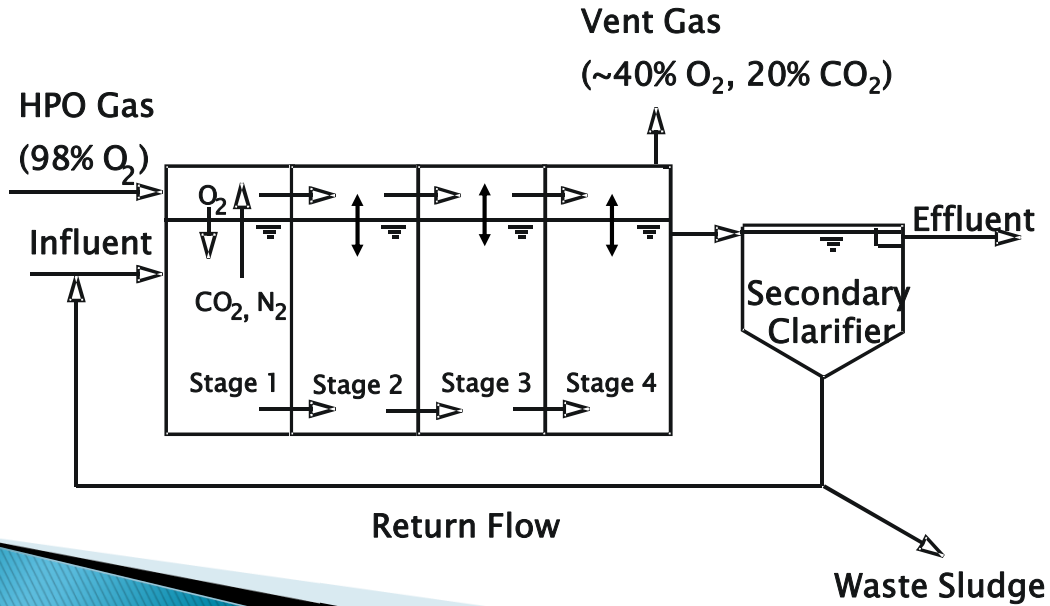

# Modified HPO Process for N Removal

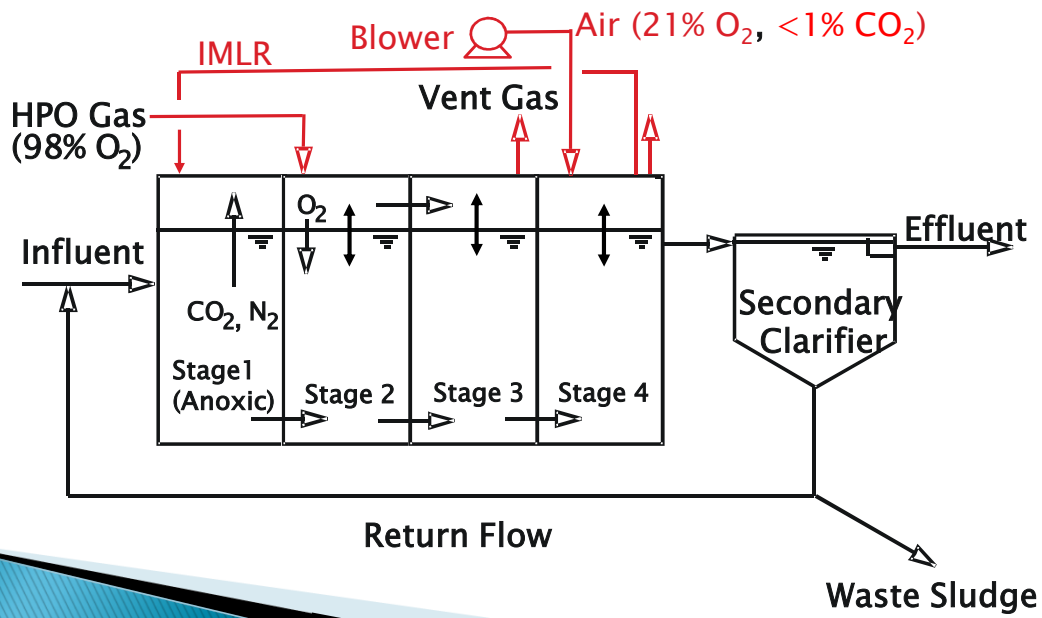

# Modified HPO Process for N Removal

## Pros

- ▶ New aeration system (diffusers and blowers) not needed
- ▶ Improved sludge settleability
- ▶ Lower HPO gas requirement
- ▶ Operator familiarity with the process

## Cons

- ▶ Reduced capacity to accommodate higher SRT
- ▶ Increased foaming/difficulty to remove foam
- ▶ Little operating experience with HPO process with N/DN
- ▶ Need to add ventilation blowers/replace aerators



## Appendix C: TM 2—South Plant

---

This page intentionally left blank.



# Technical Memorandum

701 Pike Street, Suite 1200  
Seattle, WA 98101-2310

Phone: 206-624-0100  
Fax: 206-749-2200

Prepared for: King County

Project Title: King County Flows and Loads—Nitrogen Removal Study

Project No.: 151084.460

## Technical Memorandum 2

Subject: South Plant Nitrogen Removal Technology Combinations Review and Screening

Date: June 25, 2019

To: Eron Jacobson, KC Nitrogen Removal Task Lead

From: Rick Kelly, BC Nitrogen Removal Task Lead

Copy to:

Prepared by:   
Matt Winkler, P.E., WA License. No. 52196, Expiration 3/4/2021

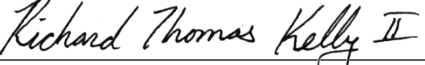
Reviewed by:   
Richard Kelly, Ph.D., P.E., WA License. No. 45235, Expiration 6/3/2021

## Introduction

The purpose of this technical memorandum (TM) is to document the results of the nitrogen removal technology screening evaluation for South Treatment Plant (South Plant). The screening evaluation presented in this TM builds upon the results from the initial screening meeting for South Plant, where a total of ten technologies were carried forward for more detailed screening. In contrast to the initial screening process, which ranked individual technologies by category, this final screening evaluation ranked combinations of the different technologies, referred to as technology combination alternatives. Brown and Caldwell (BC) developed preliminary rankings for the technology combination alternatives and conducted South Plant Nitrogen Removal Workshop 1 with King County (County) staff on May 30, 2019. During the workshop, the County and BC discussed the alternatives, revised rankings, and selected technology combination alternatives for the four nitrogen removal scenarios for South Plant. This TM summarizes the results of Workshop 1 and discusses next steps for the South Plant nitrogen removal analysis.

## Section 1: Nitrogen Removal Scenarios

The County and BC conducted a conference call on April 24, 2019, to discuss and select up to four nitrogen removal effluent limits/modifications scenarios for each of the County's three large treatment facilities (West Point Treatment Plant, South Plant, and Brightwater Treatment Plant). Four nitrogen removal scenarios were selected for South Plant:

1. Sidestream treatment, nitrification/denitrification during summer using existing infrastructure
2. Seasonal nitrogen removal, effluent total inorganic nitrogen (TIN) limit of 8 milligrams per liter (mg/L)
3. Year-round nitrogen removal, 8-mg/L TIN equivalent (different limits in summer versus winter)
4. Year-round nitrogen removal, effluent TIN limit of 3 mg/L

The scenarios are arranged in order of increasing overall nitrogen removal. For Scenario 1, sidestream treatment would operate year-round. Scenario 4, which represents the typical limits of performance for the best available nitrogen removal technologies, could be a possible scenario for South Plant if a bubble permit is used (i.e., lower effluent TIN limits for South Plant in exchange for higher effluent TIN limits at West Point Treatment Plant or Brightwater Treatment Plant). Refer to the meeting notes in Attachment A for additional information (note that the scenario numbering in the meeting notes is different). As discussed in the following sections, technology combination alternatives were evaluated and selected for each of the four nitrogen removal scenarios.

## Section 2: Overview of Technologies

This section provides background information on the technology categories and summarizes technologies remaining from the initial screening meeting for South Plant. Refer to the Nitrogen Removal Technologies Technical Summaries and Pre-Screening TM (TM 1) for more detailed information on the technologies.

## 2.1 Technology Categories/Classifications

As described in TM 1, each technology was categorized by its implementation type or plant impacts. Five categories/classifications were developed as summarized below.

- **Mainstream treatment:** Employed as the mainstream biological secondary treatment process and must be capable of nitrogen removal.
- **Sidestream treatment:** Implemented only on the plant biosolids and dewatering streams. They are capable of removing nitrogen in the biosolids/dewatering streams or used to nitrify these streams and seed nitrifiers back to the main process to allow for lower solids retention time operation of the mainstream technologies.
- **Tertiary treatment:** Used for nitrification and nitrogen removal following the mainstream biological secondary treatment process.
- **Intensification:** Allow for operating the mainstream treatment process in a smaller footprint by allowing for a higher biomass concentration in the same footprint. They do not necessarily remove nitrogen on their own but are used in conjunction with a nitrogen removal mainstream or tertiary treatment process.
- **Carbon diversion:** Remove excess biochemical oxygen demand from influent wastewater before secondary treatment, allowing for operating secondary treatment processes for nitrogen removal in a smaller footprint with less energy. These technologies also divert additional solids into digestion processes and can allow for additional biogas generation for resource recovery or reuse.

## 2.2 Technologies Remaining from Initial Screening

Table 1 summarizes the technologies remaining from the initial screening evaluation for South Plant. For the final screening evaluation presented in this TM, alternatives were developed using either a single technology from one category or multiple technologies combined from various categories (Section 3.1).

Technology	Classification
Modified Ludzack-Ettinger	Mainstream
Four-stage modified Bardenpho	Mainstream
Simultaneous nitrification/denitrification	Mainstream
Anammox	Sidestream
Bioaugmentation	Sidestream
Fixed film (nitrification/denitrification)	Tertiary
Fixed film (denitrification only)	Tertiary
Integrated fixed-film activated sludge	Intensification
Membrane aerated biofilm reactor	Intensification
Partial granulation	Intensification

## Section 3: Technology Combinations Review and Screening

This section summarizes the screening evaluation conducted during Workshop 1. It includes a review of the technology combination alternatives, screening criteria and assigned weighting scores, application of screening criteria and assigned scores for technology combination alternatives, and overall results for each nitrogen removal scenario.

### 3.1 Technology Combinations

Although most of the individual technologies provide nitrogen removal as stand-alone processes (e.g., mainstream, sidestream, or tertiary processes), some nitrogen removal scenarios will require combinations of the various technologies from different categories to meet effluent nitrogen targets while satisfying other site constraints or objectives. Table 2 shows an example of how the technologies interact or can be combined to achieve various levels of nitrogen removal or effluent TIN concentrations.

Table 2. Example of Technology Combinations for Different Effluent TIN Targets		
TIN < 20 mg/L	TIN < 8 mg/L	TIN < 3 mg/L
Sidestream only (depending on influent nitrogen and nitrogen load in dewatering return streams)	Mainstream only	Mainstream + sidestream + tertiary
Mainstream only	Mainstream + sidestream	Tertiary only
Tertiary only		Tertiary + sidestream Mainstream + intensification + sidestream

For South Plant, a total of 30 possible technology combination alternatives were developed for the screening evaluation. The technology combination alternatives are shown in the base technology combination matrix in Attachment B. However, for scenarios where a certain technology combination alternative was unable to meet the permit objectives or was not viable, the alternative was failed and removed from consideration for that scenario (only applicable for Scenario 4). The following sections provide a brief overview of alternatives that were evaluated for each scenario. Refer to the tables in Attachment B for the full list of technology combination alternatives for each scenario and justification for failing certain alternatives. The screening matrices in Section 3.3 also show the failed alternatives for each scenario.

#### 3.1.1 Scenario 1: Sidestream Treatment, Summer Nitrification/Denitrification

A screening evaluation was not required for Scenario 1. Both possible sidestream treatment alternatives, anammox and bioaugmentation, will be evaluated for Scenario 1.

#### 3.1.2 Scenario 2: Seasonal Nitrogen Removal (TIN = 8 mg/L)

All 30 technology combination alternatives were considered in the screening evaluation for Scenario 2. None of the alternatives were failed. A complete list of the technology combination alternatives for Scenario 2 is shown on Figure 2.

#### 3.1.3 Scenario 3: Year-round Nitrogen Removal (8-mg/L TIN Equivalent)

All 30 technology combination alternatives were considered in the screening evaluation for Scenario 3. None of the alternatives were failed. A complete list of the technology combination alternatives for Scenario 3 is shown on Figure 3.

#### 3.1.4 Scenario 4: Year-round Nitrogen Removal (TIN = 3 mg/L)

A total of 21 alternatives were considered in the screening evaluation for Scenario 4. All modified Ludzack-Ettinger (MLE) alternatives, except those with tertiary denitrifying fixed-film, were failed because MLE will not be able to meet an effluent TIN of 3 mg/L. A complete list of the technology combination alternatives for Scenario 4 is shown on Figure 4.

### 3.2 Screening Criteria and Weighting

BC developed preliminary screening criteria and assigned draft weighting scores that were reviewed with the County during Workshop 1. In general, the same screening criteria that were used for the initial screening evaluation (TM 1) were retained for this analysis, with the following exceptions:

- The criterion for “scalability to large wastewater treatment plant” was removed because all technologies are scalable and would have the same ranking.
- The criterion for “truck traffic” was removed because truck traffic is not a concern for South Plant (primarily applicable at West Point).
- The criterion for “resource recovery” was removed because none of the technologies considered provide a resource recovery benefit (all alternatives would have the same ranking).

Weighting scores were assigned on a 1 to 3 scale, where a score of 3 represents the greatest importance to the facility. The weighting score for each criterion is multiplied by the assigned score for that criterion for each alternative to calculate a total weighted score (Section 3.3). Table 3 summarizes the final list of screening criteria and assigned weighting scores from the workshop.

Screening criteria	Weight <sup>a</sup>	Notes or adjustments from Workshop 1
Technology status	1	Assigned a weighting score of 1 recognizing that technology status will likely change in the time between this study and actual implementation of the technologies.
Effluent nitrogen concentration	3	Increased weighting score from 2 to 3.
Load variation impact	1	
Flow variation impact	2	Increased weighting score from 1 to 2. Flow variation impact at South Plant is higher than load variation impact.
Footprint	3	Increased weighting score from 2 to 3. It was discussed that combined weighting scores for flow variation impact and footprint should be 4 or greater. Selected 3 for footprint weighting and 2 for flow variation impact. The team also needs to coordinate with other flows and loads tasks to set what footprint is actually “available” for nitrogen removal with consideration for expanding other processes required to meet plant capacity on the time horizon considered (e.g., a new digester). In addition, if no alternatives will fit on the available site footprint, such as for Scenario 4, then membrane bioreactors or need for additional property may need to be considered (to be confirmed after initial modeling/sizing of alternatives).
Impacts to other processes	1	Decreased weighting score from 2 to 1.
Energy use	2	
Greenhouse gas (GHG) emissions	2	For this evaluation, GHG emissions focus on the relative difference in nitrous oxide generation potential between nitrogen removal technologies. Other criteria for energy use and operations and maintenance (O&M) costs already include GHG emissions that would be associated with power and chemical demands. Overall GHG emissions will be evaluated for selected alternatives as part of the next phase of the project.



Table 3. Screening Criteria and Assigned Weighting Scores for South Plant		
Screening criteria	Weight <sup>a</sup>	Notes or adjustments from Workshop 1
Capital cost	1	Capital cost was assigned a low weighting score for this screening evaluation to avoid eliminating alternatives by cost alone, recognizing that alternatives with high capital cost may be the only feasible options for certain nitrogen removal scenarios. In addition, one of the County's objectives for this project is to determine costs of feasible options and have a range of capital costs for different nitrogen removal scenarios. Capital costs will be developed for selected alternatives as part of the life-cycle cost analysis in the next step of the project.
O&M cost	1	O&M cost was assigned a low weighting score for similar reasons as the capital cost criterion. O&M costs will be developed for selected alternatives as part of the life-cycle cost analysis in the next step of the project.
Constructability	1	Constructability for South Plant is less of a concern than at West Point (new tankage can be built before retrofitting existing tankage). Left at a weighting score of 1.
Operational complexity	3	Increased weighting score from 2 to 3. There was also discussion about adding safety (e.g., methanol facilities) as a new screening criterion, but the team decided to consider safety as part of the operational complexity scoring.

a. Score of 1 to 3, where 3 represents the highest weighting factor.

### 3.3 Application of Screening Criteria

The screening criteria were applied separately to each technology combination alternative. BC assigned draft scores for each criterion for each alternative before Workshop 1. Scores were adjusted based on workshop discussion. Notes from the workshop discussion are summarized below:

- The technology status ratings for all alternatives that include simultaneous nitrification/denitrification (SND) were adjusted to lower scores (i.e., changed scores from 4 to 3 or from 2 to 1). This reduction was based on the concern about the reliability of SND operation in colder climates and with high influent dissolved oxygen (DO) during peak flow events at South Plant making control of low DO concentration difficult. It was noted that most existing plants operating with SND are in areas with a warmer climate.
- For flow variation impact, a lower score was assigned for integrated fixed-film activated sludge (IFAS) alternatives because of the impact on the media sieves/screens and history of past hydraulic failures, while a higher score was assigned for partial granulation because the secondary clarifiers can operate at higher surface overflow rates.
- Footprint scores were adjusted to provide more granularity between MLE, four-stage modified Bardenpho (4SMB), and SND alternatives with and without sidestream treatment. Sidestream bioaugmentation was assumed to provide a greater footprint benefit for the mainstream process than sidestream anammox. For example, MLE, MLE with sidestream anammox, and MLE with sidestream bioaugmentation were assigned scores of 2, 3, and 4, respectively.
- The sidestream bioaugmentation process can work well in a cold climate area. The bioaugmentation process can be configured to operate at similar temperatures as the mainstream process to allow seeding of nitrifiers that are already acclimated to the mainstream process temperature.
- The scores for “impacts to other processes” were reduced for all alternatives that include tertiary fixed-film (changed scores from 4 or 5 to 3).



- For Scenarios 2 and 3, the scores for capital and operations and maintenance (O&M) costs for alternatives with tertiary fixed-film were increased for not needing to be sized for peak winter flows (i.e., some flow can be bypassed at times and still meet a monthly or yearly target). Scores of 1 were increased to 2 and scores of 2 were increased to 3. Scores for Scenario 4 were not adjusted because the tertiary process would need to be sized for peak winter flows to meet a year-round effluent TIN limit of 3 mg/L.
- Constructability scores for alternatives that include tertiary fixed-film were reduced (changed scores to 3 or 4 instead of 4 or 5). The original rankings were considered too high because the tertiary effluent would require transfer back to the Effluent Transfer System line for discharge to Puget Sound.
- The operational complexity scores for alternatives that include partial granulation were assigned lower scores because partial granulation has not been applied at full scale without an intentional biological phosphorus removal process. Plants where partial granulation has been implemented operate with both biological phosphorus and nitrogen removal, which would require an anaerobic/anoxic/oxic (A2O) or 5-stage Bardenpho configuration to incorporate an anaerobic selector. Compared to MLE or 4SMB configurations, A2O (anaerobic/anoxic/oxic) or 5-stage Bardenpho would require additional carbon and have an increased footprint to meet the same effluent nitrogen targets.

The final scoring for each alternative is shown in the base technology combination screening matrix (Figure 1). The total weighted score for each alternative was used as the primary basis for identifying recommended alternatives to carry forward for each scenario, but alternatives with lower scores were still considered where it made sense. The final technology combination screening matrices for Scenarios 2, 3, and 4 are shown on Figure 2, Figure 3, and Figure 4, respectively. The matrices for Scenarios 2, 3, and 4 use the same scores as the base matrix, except that Scenarios 2 and 3 have revised scoring for capital and O&M costs for the tertiary fixed-film technologies (Alternatives 25–28), recognizing that the tertiary fixed-film processes would not need to be sized for peak winter flows for those scenarios and would therefore have reduced costs.

Technologies	Classification	Technology combination alternatives																													
		1	2	3	4	5	6	7	8	9	10	11	12	13	14	15	16	17	18	19	20	21	22	23	24	25	26	27	28	29	30
MLE	Mainstream	✓	✓	✓	✓	✓	✓	✓	✓	✓																		✓	✓		
4SMB	Mainstream										✓	✓	✓	✓	✓	✓	✓	✓	✓												
SND	Mainstream																			✓	✓	✓	✓	✓	✓						
Anammox	Sidestream		✓				✓	✓			✓				✓	✓				✓			✓			✓		✓			
Bioaugmentation	Sidestream			✓						✓	✓			✓				✓	✓			✓			✓						
Fixed film (nit/denit)	Tertiary																									✓	✓				
Fixed film (denit only)	Tertiary																										✓	✓			
IFAS	Intensification				✓		✓			✓				✓		✓		✓													
MABR	Intensification																												✓	✓	
Partial granulation	Intensification					✓		✓		✓					✓		✓		✓				✓	✓	✓					✓	
Screening criteria	Weight <sup>2</sup>	Score <sup>1</sup>																													
Technology status	1	5	5	5	5	3	5	3	5	3	5	5	5	5	3	5	3	5	3	3	3	3	1	1	1	5	5	5	5	1	1
Effluent N concentration	3	3	4	3	3	3	4	4	3	3	4	5	4	4	4	5	5	4	4	4	5	4	4	5	4	5	5	5	5	3	3
Load variation impact	1	3	3	3	3	3	3	3	3	3	3	3	3	3	3	3	3	3	3	3	3	3	3	3	3	5	5	5	5	3	3
Flow variation impact	2	3	3	3	2	4	2	4	2	4	3	3	3	2	4	2	4	2	4	3	3	3	4	4	4	3	3	3	3	3	4
Footprint	3	2	3	4	4	4	4	4	4	4	1	2	3	3	3	3	3	3	3	1	2	3	3	3	3	2	2	3	3	3	4
Impacts to other processes	1	3	3	3	3	3	3	3	3	3	3	3	3	3	3	3	3	3	3	3	3	3	3	3	3	3	3	3	3	2	2
Energy use	2	3	4	3	1	3	1	4	1	3	3	4	3	1	3	1	4	1	3	5	5	4	5	5	4	1	1	2	2	3	3
GHG emissions	2	3	3	3	3	3	3	3	3	3	3	3	3	3	3	3	3	3	2	2	2	2	2	2	2	3	3	3	3	3	3
Capital cost	1	5	4	4	3	4	3	3	3	4	4	3	3	2	3	2	2	2	3	5	4	4	4	3	3	1	1	2	2	1	1
O&M cost	1	3	4	3	2	3	2	4	2	3	3	4	3	2	3	2	4	2	3	5	5	4	5	5	4	1	1	2	2	3	3
Constructability	1	3	3	3	2	3	2	3	2	3	3	3	3	2	3	2	3	2	3	3	3	3	3	3	3	4	4	3	3	3	3
Operational complexity	3	5	4	5	3	2	3	1	3	2	5	4	5	3	2	3	1	3	2	3	2	3	1	1	1	4	3	4	3	2	1
Total un-weighted score		41	43	42	34	38	35	39	34	38	40	42	41	33	37	34	38	33	37	40	40	39	38	38	35	37	36	40	39	30	31
Total weighted score		70	75	75	60	66	63	68	60	66	69	74	74	59	65	62	67	59	65	66	68	68	65	67	61	66	63	72	69	55	57
Selected?																															

Notes:  
 1. Score of 1 to 5, where 5 represents the greatest benefit or lowest cost, footprint, emissions, etc.  
 2. Score of 1 to 3, where 3 represents the highest weighting factor.

Figure 1. Base technology combination screening matrix for South Plant



Technologies	Classification	Technology combination alternatives																														
		1	2	3	4	5	6	7	8	9	10	11	12	13	14	15	16	17	18	19	20	21	22	23	24	25	26	27	28	29	30	
MLE	Mainstream	✓	✓	✓	✓	✓	✓	✓	✓	✓																		✓	✓			
4SMB	Mainstream										✓	✓	✓	✓	✓	✓	✓	✓	✓													
SND	Mainstream																			✓	✓	✓	✓	✓	✓							
Anammox	Sidestream		✓				✓	✓			✓				✓	✓				✓			✓			✓		✓				
Bioaugmentation	Sidestream			✓						✓	✓			✓				✓	✓			✓			✓							
Fixed film (nit/denit)	Tertiary																									✓	✓					
Fixed film (denit only)	Tertiary																											✓	✓			
IFAS	Intensification				✓		✓		✓				✓		✓		✓		✓													
MABR	Intensification																												✓	✓		
Partial granulation	Intensification					✓		✓		✓				✓		✓		✓					✓	✓	✓					✓		
Screening criteria	Weight <sup>2</sup>	Score <sup>1</sup>																														
Technology status	1	5	5	5	5	3	5	3	5	3	5	5	5	5	3	5	3	5	3	3	3	3	1	1	1	5	5	5	5	1	1	
Effluent N concentration	3	3	4	3	3	3	4	4	3	3	4	5	4	4	4	5	5	4	4	4	5	4	4	5	4	5	5	5	5	3	3	
Load variation impact	1	3	3	3	3	3	3	3	3	3	3	3	3	3	3	3	3	3	3	3	3	3	3	3	3	3	5	5	5	5	3	3
Flow variation impact	2	3	3	3	2	4	2	4	2	4	3	3	3	2	4	2	4	2	4	3	3	3	4	4	4	3	3	3	3	3	4	
Footprint	3	2	3	4	4	4	4	4	4	4	1	2	3	3	3	3	3	3	3	1	2	3	3	3	3	2	2	3	3	3	4	
Impacts to other processes	1	3	3	3	3	3	3	3	3	3	3	3	3	3	3	3	3	3	3	3	3	3	3	3	3	3	3	3	3	2	2	
Energy use	2	3	4	3	1	3	1	4	1	3	3	4	3	1	3	1	4	1	3	5	5	4	5	5	4	1	1	2	2	3	3	
GHG emissions	2	3	3	3	3	3	3	3	3	3	3	3	3	3	3	3	3	3	2	2	2	2	2	2	2	3	3	3	3	3	3	
Capital cost	1	5	4	4	3	4	3	3	3	4	4	3	3	2	3	2	2	2	3	5	4	4	4	3	3	2	2	3	3	1	1	
O&M cost	1	3	4	3	2	3	2	4	2	3	3	4	3	2	3	2	4	2	3	5	5	4	5	5	4	2	2	3	3	3	3	
Constructability	1	3	3	3	2	3	2	3	2	3	3	3	3	2	3	2	3	2	3	3	3	3	3	3	3	4	4	3	3	3	3	
Operational complexity	3	5	4	5	3	2	3	1	3	2	5	4	5	3	2	3	1	3	2	3	2	3	1	1	1	4	3	4	3	2	1	
Total un-weighted score		41	43	42	34	38	35	39	34	38	40	42	41	33	37	34	38	33	37	40	40	39	38	38	35	39	38	42	41	30	31	
Total weighted score		70	75	75	60	66	63	68	60	66	69	74	74	59	65	62	67	59	65	66	68	68	65	67	61	68	65	74	71	55	57	
Selected?		No	Yes	Yes	No	No	No	No	No	No	No	No	No	No	No	No	No	No	No	No	No	No	No	No	No	No	No	Yes	No	No	No	

Notes:  
 1. Score of 1 to 5, where 5 represents the greatest benefit or lowest cost, footprint, emissions, etc.  
 2. Score of 1 to 3, where 3 represents the highest weighting factor.

Figure 2. Technology combination screening matrix for South Plant Scenario 2 (seasonal nitrogen removal [TIN = 8 mg/L])

Technologies	Classification	Technology combination alternatives																														
		1	2	3	4	5	6	7	8	9	10	11	12	13	14	15	16	17	18	19	20	21	22	23	24	25	26	27	28	29	30	
MLE	Mainstream	✓	✓	✓	✓	✓	✓	✓	✓	✓																		✓	✓			
4SMB	Mainstream										✓	✓	✓	✓	✓	✓	✓	✓	✓													
SND	Mainstream																			✓	✓	✓	✓	✓	✓							
Anammox	Sidestream		✓				✓	✓			✓				✓	✓				✓			✓			✓		✓				
Bioaugmentation	Sidestream			✓						✓	✓			✓				✓	✓			✓			✓							
Fixed film (nit/denit)	Tertiary																									✓	✓					
Fixed film (denit only)	Tertiary																										✓	✓				
IFAS	Intensification				✓		✓		✓				✓		✓		✓															
MABR	Intensification																												✓	✓		
Partial granulation	Intensification					✓		✓		✓				✓		✓		✓					✓	✓	✓					✓		
Screening criteria	Weight <sup>2</sup>	Score <sup>1</sup>																														
Technology status	1	5	5	5	5	3	5	3	5	3	5	5	5	5	3	5	3	5	3	3	3	3	1	1	1	5	5	5	5	1	1	
Effluent N concentration	3	3	4	3	3	3	4	4	3	3	4	5	4	4	4	5	5	4	4	4	5	4	4	5	4	5	5	5	5	3	3	
Load variation impact	1	3	3	3	3	3	3	3	3	3	3	3	3	3	3	3	3	3	3	3	3	3	3	3	3	3	5	5	5	5	3	3
Flow variation impact	2	3	3	3	2	4	2	4	2	4	3	3	3	2	4	2	4	2	4	3	3	3	4	4	4	3	3	3	3	3	4	
Footprint	3	2	3	4	4	4	4	4	4	4	1	2	3	3	3	3	3	3	3	1	2	3	3	3	3	2	2	3	3	3	4	
Impacts to other processes	1	3	3	3	3	3	3	3	3	3	3	3	3	3	3	3	3	3	3	3	3	3	3	3	3	3	3	3	3	2	2	
Energy use	2	3	4	3	1	3	1	4	1	3	3	4	3	1	3	1	4	1	3	5	5	4	5	5	4	1	1	2	2	3	3	
GHG emissions	2	3	3	3	3	3	3	3	3	3	3	3	3	3	3	3	3	3	2	2	2	2	2	2	2	3	3	3	3	3	3	
Capital cost	1	5	4	4	3	4	3	3	3	4	4	3	3	2	3	2	2	2	3	5	4	4	4	3	3	2	2	3	3	1	1	
O&M cost	1	3	4	3	2	3	2	4	2	3	3	4	3	2	3	2	4	2	3	5	5	4	5	5	4	2	2	3	3	3	3	
Constructability	1	3	3	3	2	3	2	3	2	3	3	3	3	2	3	2	3	2	3	3	3	3	3	3	3	4	4	3	3	3	3	
Operational complexity	3	5	4	5	3	2	3	1	3	2	5	4	5	3	2	3	1	3	2	3	2	3	1	1	1	4	3	4	3	2	1	
Total un-weighted score		41	43	42	34	38	35	39	34	38	40	42	41	33	37	34	38	33	37	40	40	39	38	38	35	39	38	42	41	30	31	
Total weighted score		70	75	75	60	66	63	68	60	66	69	74	74	59	65	62	67	59	65	66	68	68	65	67	61	68	65	74	71	55	57	
Selected?		No	No	No	No	No	No	No	No	No	No	Yes	Yes	No	No	No	No	No	No	No	No	No	No	No	No	No	Yes	No	No	No	No	

Notes:  
 1. Score of 1 to 5, where 5 represents the greatest benefit or lowest cost, footprint, emissions, etc.  
 2. Score of 1 to 3, where 3 represents the highest weighting factor.

Figure 3. Technology combination screening matrix for South Plant Scenario 3 (year-round nitrogen removal [8-mg/L TIN equivalent])



Technologies	Classification	Technology combination alternatives																															
		1	2	3	4	5	6	7	8	9	10	11	12	13	14	15	16	17	18	19	20	21	22	23	24	25	26	27	28	29	30		
MLE	Mainstream	✓	✓	✓	✓	✓	✓	✓	✓	✓																		✓	✓				
4SMB	Mainstream										✓	✓	✓	✓	✓	✓	✓	✓	✓														
SND	Mainstream																			✓	✓	✓	✓	✓	✓								
Anammox	Sidestream		✓				✓	✓			✓				✓	✓				✓			✓			✓		✓					
Bioaugmentation	Sidestream			✓						✓			✓				✓	✓			✓			✓									
Fixed film (nit/denit)	Tertiary																									✓	✓						
Fixed film (denit only)	Tertiary																											✓	✓				
IFAS	Intensification				✓		✓		✓				✓		✓		✓																
MABR	Intensification																												✓	✓			
Partial granulation	Intensification					✓		✓		✓				✓		✓		✓					✓	✓	✓					✓			
Screening criteria	Weight <sup>2</sup>	Score <sup>1</sup>																															
Technology status	1											5	5	5	5	3	5	3	5	3	3	3	3	3	1	1	1	5	5	5	5	1	1
Effluent N concentration	3											4	5	4	4	4	5	5	4	4	4	5	4	4	5	4	5	5	5	5	3	3	
Load variation impact	1											3	3	3	3	3	3	3	3	3	3	3	3	3	3	3	3	5	5	5	5	3	3
Flow variation impact	2											3	3	3	2	4	2	4	2	4	3	3	3	4	4	4	3	3	3	3	3	4	
Footprint	3											1	2	3	3	3	3	3	3	3	3	1	2	3	3	3	3	2	2	3	3	4	
Impacts to other processes	1											3	3	3	3	3	3	3	3	3	3	3	3	3	3	3	3	3	3	3	2	2	
Energy use	2											3	4	3	1	3	1	4	1	3	5	5	4	5	5	4	1	1	2	2	3	3	
GHG emissions	2											3	3	3	3	3	3	3	3	3	2	2	2	2	2	2	3	3	3	3	3	3	
Capital cost	1											4	3	3	2	3	2	2	2	3	5	4	4	4	3	3	1	1	2	2	1	1	
O&M cost	1											3	4	3	2	3	2	4	2	3	5	5	4	5	5	4	1	1	2	2	3	3	
Constructability	1											3	3	3	2	3	2	3	2	3	3	3	3	3	3	3	4	4	3	3	3	3	
Operational complexity	3											5	4	5	3	2	3	1	3	2	3	2	3	1	1	1	4	3	4	3	2	1	
Total un-weighted score		Fail	Fail	Fail	Fail	Fail	Fail	Fail	Fail	Fail	Fail	40	42	41	33	37	34	38	33	37	40	40	39	38	38	35	37	36	40	39	30	31	
Total weighted score		Fail	Fail	Fail	Fail	Fail	Fail	Fail	Fail	Fail	Fail	69	74	74	59	65	62	67	59	65	66	68	68	65	67	61	66	63	72	69	55	57	
Selected?		No	No	No	No	No	No	No	No	No	No	No	Yes	Yes	No	No	No	No	No	No	No	No	No	No	No	No	Yes	No	Yes	No	No	No	

Notes:  
 1. Score of 1 to 5, where 5 represents the greatest benefit or lowest cost, footprint, emissions, etc.  
 2. Score of 1 to 3, where 3 represents the highest weighting factor.

Figure 4. Technology combination screening matrix for South Plant Scenario 4 (year-round nitrogen removal [TIN = 3 mg/L])



### 3.4 Results of Screening Evaluation

This section summarizes the results of the screening evaluation for each scenario.

#### 3.4.1 Scenario 1: Sidestream Treatment, Summer Nitrification/Denitrification

Both sidestream anammox and sidestream bioaugmentation were selected without a full screening because they are the only two viable options for evaluation (see discussion in Section 3.1.1). These alternatives will both retain the existing mainstream process.

#### 3.4.2 Scenario 2: Seasonal Nitrogen Removal (TIN = 8 mg/L)

Table 4 shows the total weighted scores from the workshop and selected alternatives for Scenario 2. The two alternatives with the highest total weighted score, MLE with sidestream anammox and MLE with sidestream bioaugmentation, were selected for detailed evaluation. The next three highest scoring alternatives all have the same total weighted score (74), where two of the alternatives use 4SMB with sidestream treatment (Alternatives 11 and 12) and one alternative uses MLE with a tertiary denitrification process (Alternative 27). Because Scenario 2 is based on a nitrogen removal limit of 8 mg/L TIN, the team decided to select MLE with tertiary denitrifying fixed-film as the third alternative for Scenario 2 as 4SMB systems are not necessary to achieve 8 mg/L effluent TIN.

Alternative	Description	Total weighted score	Selected?
2	MLE + sidestream anammox	75	Yes
3	MLE + sidestream bioaugmentation	75	Yes
11	4SMB + sidestream anammox	74	No
12	4SMB + sidestream bioaugmentation	74	No
27	MLE + tertiary denitrifying fixed-film	74	Yes
28	MLE + tertiary denitrifying fixed-film + sidestream anammox	71	No
1	MLE	70	No
10	4SMB	69	No
7	MLE + partial granulation + sidestream anammox	68	No
20	SND + sidestream anammox	68	No
21	SND + sidestream bioaugmentation	68	No
25	Existing mainstream + tertiary nitrifying/denitrifying fixed-film	68	No
16	4SMB + partial granulation + sidestream anammox	67	No
23	SND + partial granulation + sidestream anammox	67	No
5	MLE + partial granulation	66	No
9	MLE + partial granulation + sidestream bioaugmentation	66	No
19	SND	66	No
14	4SMB + partial granulation	65	No
18	4SMB + partial granulation + sidestream bioaugmentation	65	No
22	SND + partial granulation	65	No
26	Existing mainstream + tertiary nitrifying/denitrifying fixed-film + sidestream anammox	65	No



Table 4. Results of Screening Evaluation for South Plant Scenario 2 <sup>a</sup>			
Alternative	Description	Total weighted score	Selected?
6	MLE/IFAS + sidestream anammox	63	No
15	4SMB/IFAS + sidestream anammox	62	No
24	SND + partial granulation + sidestream bioaugmentation	61	No
4	MLE/IFAS	60	No
8	MLE/IFAS + sidestream bioaugmentation	60	No
13	4SMB/IFAS	59	No
17	4SMB/IFAS + sidestream bioaugmentation	59	No
30	MABR + partial granulation	57	No
29	MABR	55	No

a. Alternatives are sorted by highest total weighted score. Failed alternatives are not shown.  
MABR = membrane aerated biofilm reactor.

### 3.4.3 Scenario 3: Year-round Nitrogen Removal (8-mg/L TIN Equivalent)

Table 5 shows the total weighted scores from the workshop and selected alternatives for Scenario 3. The highest weighted score options were MLE with sidestream treatment. These were not carried forward for evaluation because the County is more interested in a flexible system that would allow for higher than 8 mg/L TIN effluent in the winter if lower than 8 mg/L TIN is possible in the summer. This is why the 4SMB alternatives 11 and 12 were selected for detailed evaluation. The 4SMB alternatives will be configured such that the second anoxic zone is a swing zone (equipped with both aeration and mechanical mixing to allow aerated or unaerated operation), which will allow operation in 4SMB mode in the summer and MLE mode in the winter. Operating in MLE mode during the winter would provide greater aerobic volume and reduce the total aeration basin volume required for winter nitrification, while operating in 4SMB mode during the summer would allow lower effluent TIN to be achieved during the warmer months, offsetting higher effluent TIN from winter MLE operation. This approach makes sense for the 8-mg/L TIN equivalent target for Scenario 3, where lower limits are assumed for summer and higher limits are assumed for winter. The final selected alternative for Scenario 3 would keep the existing mainstream process and add tertiary fixed-film processes for nitrification and denitrification (Alternative 25). Alternative 25 was chosen over Alternative 27 (MLE with tertiary denitrifying fixed-film) because the potential footprint and construction advantage of a tertiary only system was of interest for this planning level study. It will provide an estimate of how much tertiary treatment would cost from a capital and operational perspective. Keeping the existing mainstream process would also be a probable alternative at South Plant if adding tertiary treatment.



<b>Table 5. Results of Screening Evaluation for South Plant Scenario 3<sup>a</sup></b>			
<b>Alternative</b>	<b>Description</b>	<b>Total weighted score</b>	<b>Selected?</b>
2	MLE + sidestream anammox	75	No
3	MLE + sidestream bioaugmentation	75	No
11	4SMB + sidestream anammox	74	Yes
12	4SMB + sidestream bioaugmentation	74	Yes
27	MLE + tertiary denitrifying fixed-film	74	No
28	MLE + tertiary denitrifying fixed-film + sidestream anammox	71	No
1	MLE	70	No
10	4SMB	69	No
7	MLE + partial granulation + sidestream anammox	68	No
20	SND + sidestream anammox	68	No
21	SND + sidestream bioaugmentation	68	No
25	Existing mainstream + tertiary nitrifying/denitrifying fixed-film	68	Yes
16	4SMB + partial granulation + sidestream anammox	67	No
23	SND + partial granulation + sidestream anammox	67	No
5	MLE + partial granulation	66	No
9	MLE + partial granulation + sidestream bioaugmentation	66	No
19	SND	66	No
14	4SMB + partial granulation	65	No
18	4SMB + partial granulation + sidestream bioaugmentation	65	No
22	SND + partial granulation	65	No
26	Existing mainstream + tertiary nitrifying/denitrifying fixed-film + sidestream anammox	65	No
6	MLE/IFAS + sidestream anammox	63	No
15	4SMB/IFAS + sidestream anammox	62	No
24	SND + partial granulation + sidestream bioaugmentation	61	No
4	MLE/IFAS	60	No
8	MLE/IFAS + sidestream bioaugmentation	60	No
13	4SMB/IFAS	59	No
17	4SMB/IFAS + sidestream bioaugmentation	59	No
30	MABR + partial granulation	57	No
29	MABR	55	No

a. Alternatives are sorted by highest total weighted score. Failed alternatives are not shown.



### 3.4.4 Scenario 4: Year-Round Nitrogen Removal (TIN = 3 mg/L)

Table 6 shows the total weighted scores from the workshop and selected alternatives for Scenario 4. The three highest scoring alternatives (11, 12, and 27) were selected for detailed evaluation. Alternative 25 was also selected for the same reasons as described above for Scenario 3.

Table 6. Results of Screening Evaluation for South Plant Scenario 4 <sup>a</sup>			
Alternative	Description	Total weighted score	Selected?
11	4SMB + sidestream anammox	74	Yes
12	4SMB + sidestream bioaugmentation	74	Yes
27	MLE + tertiary denitrifying fixed-film	72	Yes
28	MLE + tertiary denitrifying fixed-film + sidestream anammox	69	No
10	4SMB	69	No
20	SND + sidestream anammox	68	No
21	SND + sidestream bioaugmentation	68	No
16	4SMB + partial granulation + sidestream anammox	67	No
23	SND + partial granulation + sidestream anammox	67	No
25	Existing mainstream + tertiary nitrifying/denitrifying fixed-film	66	Yes
19	SND	66	No
14	4SMB + partial granulation	65	No
18	4SMB + partial granulation + sidestream bioaugmentation	65	No
22	SND + partial granulation	65	No
26	Existing mainstream + tertiary nitrifying/denitrifying fixed-film + sidestream anammox	63	No
15	4SMB/IFAS + sidestream anammox	62	No
24	SND + partial granulation + sidestream bioaugmentation	61	No
13	4SMB/IFAS	59	No
17	4SMB/IFAS + sidestream bioaugmentation	59	No
30	MABR + partial granulation	57	No
29	MABR	55	No

a. Alternatives are sorted by highest total weighted score. Failed alternatives are not shown.

### 3.5 Summary of Selected Alternatives

Table 7 summarizes the selected alternatives for each scenario and identifies the alternative numbering that will be used during the next phase of the project (e.g., Alternatives 1A, 1B, 2A, 2B, etc.).

<b>Table 7. Summary of Selected Alternatives for South Plant Nitrogen Removal Scenarios</b>	
<b>Alternative</b>	<b>Description</b>
<b>Scenario 1: Sidestream treatment, nitrification/denitrification during summer using existing infrastructure</b>	
1A	Existing mainstream + sidestream anammox
1B	Existing mainstream + sidestream bioaugmentation
<b>Scenario 2: Seasonal N removal, effluent TIN limit of 8 mg/L</b>	
2A	MLE + tertiary denitrifying fixed-film
2B	MLE + sidestream anammox
2C	MLE + sidestream bioaugmentation
<b>Scenario 3: Year-round N removal, 8-mg/L TIN equivalent</b>	
3A	4SMB + sidestream anammox
3B	4SMB + sidestream bioaugmentation
3C	Existing mainstream + tertiary nitrifying/denitrifying fixed-film
<b>Scenario 4: Year-round N removal, effluent TIN limit of 3 mg/L</b>	
4A	4SMB + sidestream anammox
4B	4SMB + sidestream bioaugmentation
4C	MLE + tertiary denitrifying fixed-film
4D	Existing mainstream + tertiary nitrifying/denitrifying fixed-film

### Section 4: Next Steps

The selected alternatives for South Plant will be modeled and sized. The preliminary modeling results will be reviewed with the County before developing layouts, costs, and greenhouse gas emissions estimates. BC recommends scheduling a modeling review meeting/conference call for late August 2019.



## **Attachment A: Meeting Notes from Nitrogen Effluent Limit Conference Call**

---



# Meeting Notes

**Prepared for:** King County Wastewater Treatment Division

**Project Title:** Nitrogen (N) Removal Analysis

**Contract No.:** 1170-17 VLN

**Meeting Name:** Nitrogen Effluent Limit Discussion Conference Call

**Meeting Location:** Brightwater, Little Bear Creek Conference Room; South Plant, Black River Conference Room; West Point, Mt. Rainier Conference Room (or Skype)

**Meeting Date:** April 24, 2019

**Meeting Time:** 10:00 am to 11:30 am

**Purpose:** Discuss and select up to four effluent nitrogen conditions for each plant to be used as the basis for evaluation.

Invitees:	<u>Consultant Team:</u>	<u>King County:</u>	
	Rick Kelly (BC) Matt Winkler (BC) Patricia Tam (BC)	Eron Jacobson Tiffany Knapp John Conway Matthew Nolan Rick Butler Bob Bucher Eugene Sugita Jessica Tanumihardja Al Williamson Mike Wohlfert Jacque Klug Sally Gordon Tushar Khurana Jeff Lafer Robert Edsforth	Andy Strehler Carol Nelson Bob Bucher Karla Guevarra <del>Rebecca Gauff</del> Bruce Nairn Truong Phuong Tom Bauer Curtis Steinke Jeff Fugier Scott Drennen Steve Huang <del>Henry Campbell</del> Sue Meyer Carl Grodnik

## Notes

---

- Considerations for selecting four conditions at each plant:
  - Create a range of removal levels to help develop cost curves
  - Develop most cost effective options at each plant
  - Identify limits for each plant where costs increase significantly
  - Include likely concentrations limits as demonstrated by DoE's Bounding Scenarios (especially lowest limit(s))
  - Develop a range of removal levels for each plant to have data to support bubble/umbrella permit scenarios
  - Consider cap mentioned in DoE AKART response
- West Point Limits / Modifications
  1. Side stream treatment, year round (assuming it can fit on site)
  2. Lowest removal level possible, year-round, maintaining existing plant capacity
  3. Lowest removal level possible, seasonal, maintaining same plant capacity
  4. 8 mg/L, year-round, identify the reduced capacity of the plant
  - Notes:

- For #4, may need to consider changes to permitting and West Point operations, depending on the secondary capacity remaining at the plant with the proposed additions of nutrient removal
- It was noted that the significant amount of snowmelt this year led to abnormally low influent temperature at West Point (less than 8-9 deg C). This will need to be incorporated into the evaluation for winter scenarios.
- South Plant Limits / Modifications
  1. Side stream treatment, year round, nitrification/de-nitrification during summer with existing infrastructure
  2. 3 mg/L, year-round
  3. 8 mg/L equivalent, year-round, most cost-effective approach (e.g. 5 mg/L summer and 12 mg/L winter)
  4. 8 mg/L, seasonally
  - Notes:
    - Potential to switch between N removal in summer and bio-P in winter, similar to current operation when nitrifying in summer
    - The option to try to maximize N removal with existing basins (i.e. relocate baffles, add IMLR pumps, and/or add carbon addition) was deemed to provide less information that determining the optimal configuration to achieve a given concentration. A review of necessary modifications to existing tanks and other infrastructure could then be evaluated to meet the optimal configuration.
- Brightwater Limits / Modifications
  1. 3 mg/L, year-round
  2. 8 mg/L equivalent, year-round, most cost-effective approach (e.g. 5 mg/L summer and 12 mg/L winter)
  3. Side-stream treatment with Brightwater Aeration Basin Optimization (BWABO) upgrades assumed to be complete including Simultaneous Nitrification Denitrification (SND)
  4. Left open for now
  - Notes:
    - Nitrogen removal from SND needs to be modeled in greater detail. Performance is uncertain because of the differences compared to other operating SND facilities (lower temperatures, membrane application, etc.)
    - While BW could potentially take more flow, from SP for example, and potentially remove more N more cost effectively, this analysis goes beyond the scope of the project. Ultimately, this configuration should be considered once permit requirements are better understood (along with other flow redistribution configurations).
    - Brightwater has planned expansion for Aeration Basin #4. Consider the expansion when developing various technologies and the associated removal limits and strategies.

## **Attachment B: Technology Combinations**

---



Base technology combination matrix													
Technology combination alternatives	Description	Mainstream			Sidestream		Tertiary		Intensification			Pass/Fail	Justification for failure
		MLE	4SMB	SND	Anammox	Bioaugmentation	Fixed film (nit/denit)	Fixed film (denit only)	IFAS	MABR	Partial granulation		
1	MLE	✓											
2	MLE + sidestream anammox	✓			✓								
3	MLE + sidestream bioaugmentation	✓				✓							
4	MLE/IFAS	✓						✓					
5	MLE + partial granulation	✓								✓			
6	MLE/IFAS + sidestream anammox	✓			✓			✓					
7	MLE + partial granulation + sidestream anammox	✓			✓					✓			
8	MLE/IFAS + sidestream bioaugmentation	✓				✓		✓					
9	MLE + partial granulation + sidestream bioaugmentation	✓				✓				✓			
10	4SMB		✓										
11	4SMB + sidestream anammox		✓		✓								
12	4SMB + sidestream bioaugmentation		✓			✓							
13	4SMB/IFAS		✓					✓					
14	4SMB + partial granulation		✓							✓			
15	4SMB/IFAS + sidestream anammox		✓		✓			✓					
16	4SMB + partial granulation + sidestream anammox		✓		✓					✓			
17	4SMB/IFAS + sidestream bioaugmentation		✓			✓		✓					
18	4SMB + partial granulation + sidestream bioaugmentation		✓			✓				✓			
19	SND			✓									
20	SND + sidestream anammox			✓	✓								
21	SND + sidestream bioaugmentation			✓		✓							
22	SND + partial granulation			✓						✓			
23	SND + partial granulation + sidestream anammox			✓	✓					✓			
24	SND + partial granulation + sidestream bioaugmentation			✓		✓				✓			
25	Existing mainstream + tertiary nitrifying/denitrifying fixed-film						✓						
26	Existing mainstream + tertiary nitrifying/denitrifying fixed-film + sidestream anammox				✓		✓						
27	MLE + tertiary denitrifying fixed-film	✓						✓					
28	MLE + tertiary denitrifying fixed-film + sidestream anammox	✓			✓			✓					
29	MABR								✓				
30	MABR + partial granulation								✓	✓			

Scenario 2: Seasonal N removal, effluent TIN limit of 8 mg/L

Technology combination alternatives	Description	Mainstream			Sidestream		Tertiary		Intensification			Pass/Fail	Justification for failure
		MLE	4SMB	SND	Anammox	Bioaugmentation	Fixed film (nit/denit)	Fixed film (denit only)	IFAS	MABR	Partial granulation		
1	MLE	✓										Pass	
2	MLE + sidestream anammox	✓			✓							Pass	
3	MLE + sidestream bioaugmentation	✓				✓						Pass	
4	MLE/IFAS	✓						✓				Pass	
5	MLE + partial granulation	✓								✓		Pass	
6	MLE/IFAS + sidestream anammox	✓			✓			✓				Pass	
7	MLE + partial granulation + sidestream anammox	✓			✓					✓		Pass	
8	MLE/IFAS + sidestream bioaugmentation	✓				✓		✓				Pass	
9	MLE + partial granulation + sidestream bioaugmentation	✓				✓				✓		Pass	
10	4SMB		✓									Pass	
11	4SMB + sidestream anammox		✓		✓							Pass	
12	4SMB + sidestream bioaugmentation		✓			✓						Pass	
13	4SMB/IFAS		✓					✓				Pass	
14	4SMB + partial granulation		✓							✓		Pass	
15	4SMB/IFAS + sidestream anammox		✓		✓			✓				Pass	
16	4SMB + partial granulation + sidestream anammox		✓		✓					✓		Pass	
17	4SMB/IFAS + sidestream bioaugmentation		✓			✓		✓				Pass	
18	4SMB + partial granulation + sidestream bioaugmentation		✓			✓				✓		Pass	
19	SND			✓								Pass	
20	SND + sidestream anammox			✓	✓							Pass	
21	SND + sidestream bioaugmentation			✓		✓						Pass	
22	SND + partial granulation			✓						✓		Pass	
23	SND + partial granulation + sidestream anammox			✓	✓					✓		Pass	
24	SND + partial granulation + sidestream bioaugmentation			✓		✓				✓		Pass	
25	Existing mainstream + tertiary nitrifying/denitrifying fixed-film						✓					Pass	
26	Existing mainstream + tertiary nitrifying/denitrifying fixed-film + sidestream anammox				✓		✓					Pass	
27	MLE + tertiary denitrifying fixed-film	✓						✓				Pass	
28	MLE + tertiary denitrifying fixed-film + sidestream anammox	✓			✓			✓				Pass	
29	MABR								✓			Pass	
30	MABR + partial granulation								✓	✓		Pass	



Scenario 3: Year-round N removal, 8-mg/L TIN equivalent													
Technology combination alternatives	Description	Mainstream			Sidestream		Tertiary		Intensification			Pass/Fail	Justification for failure
		MLE	4SMB	SND	Anammox	Bioaugmentation	Fixed film (nit/denit)	Fixed film (denit only)	IFAS	MABR	Partial granulation		
1	MLE	✓										Pass	
2	MLE + sidestream anammox	✓			✓							Pass	
3	MLE + sidestream bioaugmentation	✓				✓						Pass	
4	MLE/IFAS	✓						✓				Pass	
5	MLE + partial granulation	✓								✓		Pass	
6	MLE/IFAS + sidestream anammox	✓			✓			✓				Pass	
7	MLE + partial granulation + sidestream anammox	✓			✓					✓		Pass	
8	MLE/IFAS + sidestream bioaugmentation	✓				✓		✓				Pass	
9	MLE + partial granulation + sidestream bioaugmentation	✓				✓				✓		Pass	
10	4SMB		✓									Pass	
11	4SMB + sidestream anammox		✓		✓							Pass	
12	4SMB + sidestream bioaugmentation		✓			✓						Pass	
13	4SMB/IFAS		✓					✓				Pass	
14	4SMB + partial granulation		✓							✓		Pass	
15	4SMB/IFAS + sidestream anammox		✓		✓			✓				Pass	
16	4SMB + partial granulation + sidestream anammox		✓		✓					✓		Pass	
17	4SMB/IFAS + sidestream bioaugmentation		✓			✓		✓				Pass	
18	4SMB + partial granulation + sidestream bioaugmentation		✓			✓				✓		Pass	
19	SND			✓								Pass	
20	SND + sidestream anammox			✓	✓							Pass	
21	SND + sidestream bioaugmentation			✓		✓						Pass	
22	SND + partial granulation			✓						✓		Pass	
23	SND + partial granulation + sidestream anammox			✓	✓					✓		Pass	
24	SND + partial granulation + sidestream bioaugmentation			✓		✓				✓		Pass	
25	Existing mainstream + tertiary nitrifying/denitrifying fixed-film						✓					Pass	
26	Existing mainstream + tertiary nitrifying/denitrifying fixed-film + sidestream anammox				✓		✓					Pass	
27	MLE + tertiary denitrifying fixed-film	✓						✓				Pass	
28	MLE + tertiary denitrifying fixed-film + sidestream anammox	✓			✓			✓				Pass	
29	MABR								✓			Pass	
30	MABR + partial granulation								✓	✓		Pass	

Scenario 4: Year-round N removal, effluent TIN limit of 3 mg/L

Technology combination alternatives	Description	Mainstream			Sidestream		Tertiary		Intensification			Pass/Fail	Justification for failure
		MLE	4SMB	SND	Anammox	Bioaugmentation	Fixed film (nit/denit)	Fixed film (denit only)	IFAS	MABR	Partial granulation		
1	MLE	✓										Fail	Unlikely to be able to meet TIN limit of 3 mg/L.
2	MLE + sidestream anammox	✓			✓							Fail	
3	MLE + sidestream bioaugmentation	✓				✓						Fail	
4	MLE/IFAS	✓						✓				Fail	
5	MLE + partial granulation	✓								✓		Fail	
6	MLE/IFAS + sidestream anammox	✓			✓			✓				Fail	
7	MLE + partial granulation + sidestream anammox	✓			✓					✓		Fail	
8	MLE/IFAS + sidestream bioaugmentation	✓				✓		✓				Fail	
9	MLE + partial granulation + sidestream bioaugmentation	✓				✓				✓		Fail	
10	4SMB		✓									Pass	
11	4SMB + sidestream anammox		✓		✓							Pass	
12	4SMB + sidestream bioaugmentation		✓			✓						Pass	
13	4SMB/IFAS		✓					✓				Pass	
14	4SMB + partial granulation		✓							✓		Pass	
15	4SMB/IFAS + sidestream anammox		✓		✓			✓				Pass	
16	4SMB + partial granulation + sidestream anammox		✓		✓					✓		Pass	
17	4SMB/IFAS + sidestream bioaugmentation		✓			✓		✓				Pass	
18	4SMB + partial granulation + sidestream bioaugmentation		✓			✓				✓		Pass	
19	SND			✓								Pass	
20	SND + sidestream anammox			✓	✓							Pass	
21	SND + sidestream bioaugmentation			✓		✓						Pass	
22	SND + partial granulation			✓						✓		Pass	
23	SND + partial granulation + sidestream anammox			✓	✓					✓		Pass	
24	SND + partial granulation + sidestream bioaugmentation			✓		✓				✓		Pass	
25	Existing mainstream + tertiary nitrifying/denitrifying fixed-film						✓					Pass	
26	Existing mainstream + tertiary nitrifying/denitrifying fixed-film + sidestream anammox				✓		✓					Pass	
27	MLE + tertiary denitrifying fixed-film	✓						✓				Pass	
28	MLE + tertiary denitrifying fixed-film + sidestream anammox	✓			✓			✓				Pass	
29	MABR								✓			Pass	
30	MABR + partial granulation								✓	✓		Pass	

## Appendix D: TM 2—Brightwater

---

This page intentionally left blank.



# Technical Memorandum

701 Pike Street, Suite 1200  
Seattle, WA 98101-2310

Phone: 206-624-0100  
Fax: 206-749-2200

Prepared for: King County

Project Title: King County Flows and Loads—Nitrogen Removal Study

Project No.: 151084.460

## Technical Memorandum 2

Subject: Brightwater Nitrogen Removal Technology Combinations Review and Screening

Date: June 25, 2019

To: Eron Jacobson, King County Nitrogen Removal Task Lead

From: Rick Kelly, BC Nitrogen Removal Task Lead

Copy to:

Prepared by:   
Matt Winkler, P.E., WA License. No. 52196, Expiration 3/4/2021

Reviewed by:   
Richard Kelly, Ph.D., P.E., WA License. No. 45235, Expiration 6/3/2021

## Introduction

The purpose of this technical memorandum (TM) is to document the results of the nitrogen removal technology screening evaluation for Brightwater Treatment Plant (Brightwater). The screening evaluation presented in this TM builds upon the results from the initial screening meeting for Brightwater, where a total of eight technologies were carried forward for more detailed screening. In contrast to the initial screening process, which ranked individual technologies by category, this final screening evaluation ranked combinations of the different technologies, referred to as technology combination alternatives. Brown and Caldwell (BC) developed preliminary rankings for the technology combination alternatives and conducted Brightwater Nitrogen Removal Workshop 1 with King County (County) staff on June 10, 2019. During the workshop, the County and BC discussed the alternatives, revised rankings, and selected technology combination alternatives for the four nitrogen removal scenarios for Brightwater. This TM summarizes the results of Workshop 1 and discusses next steps for the Brightwater nitrogen removal analysis.

## Section 1: Nitrogen Removal Scenarios

The County and BC conducted a conference call on April 24, 2019, to discuss and select up to four nitrogen removal effluent limits/modifications scenarios for each of the County's three large treatment facilities (West Point Treatment Plant, South Treatment Plant, and Brightwater). Three nitrogen removal scenarios were selected for Brightwater (the fourth scenario was left open for now):

1. Simultaneous nitrification/denitrification (SND) with sidestream treatment
2. Year-round nitrogen removal, 8 milligram per liter (mg/L) total inorganic nitrogen (TIN) equivalent (different limits in summer versus winter)
3. Year-round nitrogen removal, effluent TIN limit of 3 mg/L

The scenarios are arranged in order of increasing overall nitrogen removal. For Scenario 1, sidestream treatment would operate year-round and SND is assumed to be based on upgrades that will be completed with the Brightwater Aeration Basin Optimization (BWABO) Project. SND upgrades currently being pursued with the BWABO project are focused on reducing alkalinity and aeration demands while minimizing changes to the existing system; BWABO upgrades are not being designed to a specific effluent nitrogen target. Where SND is considered for Scenarios 2 and 3, the mainstream SND process would be optimally sized to meet the effluent nitrogen targets for the respective scenarios at the design flows/loads selected for the nitrogen removal study.

A fourth scenario for Brightwater was left open following the nitrogen effluent limits conference call. However, there was some discussion during Workshop 1 about selecting a fourth concentration limit of 8 mg/L year-round with potential consideration for biological phosphorus removal. The 8-mg/L TIN limit would generally meet a total nitrogen (TN) concentration of 10 mg/L for aquifer recharge (through surface percolation). However, if aquifer recharge were applied year-round, then a constant TN limit of 10 mg/L would apply year-round, not an equivalent limit with different seasonal limits. Phosphorus removal wouldn't be required for aquifer recharge (and would consume carbon), but phosphorus is an issue with some reclaimed water customers and levels could increase with the implementation of nitrogen removal. This topic was ultimately tabled with the idea to reassess after completing the modeling for the other scenarios.

Refer to the meeting notes for the nitrogen effluent limits conference call in Attachment A for additional information on the nitrogen removal scenarios (note that the scenario numbering in the meeting notes is different). As discussed in the following sections, technology combination alternatives were evaluated and selected for each of the three nitrogen removal scenarios.



## Section 2: Overview of Technologies

This section provides background information on the technology categories and summarizes technologies remaining from the initial screening meeting for Brightwater. Refer to the Nitrogen Removal Technologies Technical Summaries and Pre-Screening TM (TM 1) for more detailed information on the technologies.

### 2.1 Technology Categories/Classifications

As described in TM 1, each technology was categorized by its implementation type or plant impacts. Five categories/classifications were developed as summarized below.

- **Mainstream treatment:** Employed as the mainstream biological secondary treatment process and must be capable of nitrogen removal.
- **Sidestream treatment:** Implemented only on the plant biosolids and dewatering streams. They are capable of removing nitrogen in the biosolids/dewatering streams or used to nitrify these streams and seed nitrifiers back to the main process to allow for lower solids retention time operation of the mainstream technologies.
- **Tertiary treatment:** Used for nitrification and nitrogen removal following the mainstream biological secondary treatment process.
- **Intensification:** Allows for operating the mainstream treatment process in a smaller footprint by allowing for a higher biomass concentration in the same footprint. They do not necessarily remove nitrogen on their own but are used in conjunction with a nitrogen removal mainstream or tertiary treatment process.
- **Carbon diversion:** Removes excess biochemical oxygen demand from influent wastewater before secondary treatment, allowing for operating secondary treatment processes for nitrogen removal in a smaller footprint with less energy. These technologies also divert additional solids into digestion processes and can allow for additional biogas generation for resource recovery or reuse.

### 2.2 Technologies Remaining from Initial Screening

Table 1 summarizes the technologies remaining from the initial screening evaluation for Brightwater. As discussed in TM 1, Brightwater already has two of the technologies installed (membrane bioreactor [MBR] and chemically enhanced primary treatment [CEPT]). In addition, Brightwater currently operates a modified Ludzack-Ettinger (MLE) process for nitrogen removal, but the existing process has an under-sized anoxic zone and limited internal mixed liquor recycle (IMLR) pumping capacity. Brightwater is also currently pursuing SND implementation as part of the BWABO Project, though for minimizing operational costs and capital improvements, not to meet an effluent TIN limit. For the final screening evaluation presented in this TM, alternatives were developed using either a single technology from one category or multiple technologies combined from various categories (Section 3.1).

**Table 1. Technologies Remaining from Initial Screening for Brightwater**

Technology	Classification
Modified Ludzack-Ettinger	Mainstream
Four-stage modified Bardenpho	Mainstream
Simultaneous nitrification/denitrification (SND)	Mainstream
Anammox	Sidestream
Fixed film (denitrification only)	Tertiary
Membrane bioreactor	Intensification
Partial granulation	Intensification
Chemically enhanced primary treatment	Carbon diversion

### Section 3: Technology Combinations Review and Screening

This section summarizes the screening evaluation conducted during Workshop 1. It includes a review of the technology combination alternatives, screening criteria and assigned weighting scores, application of screening criteria and assigned scores for technology combination alternatives, and overall results for each nitrogen removal scenario.

#### 3.1 Technology Combinations

Although most of the individual technologies provide nitrogen removal as stand-alone processes (e.g., mainstream, sidestream, or tertiary processes), some nitrogen removal scenarios will require combinations of the various technologies from different categories to meet effluent nitrogen targets while satisfying other site constraints or objectives. Table 2 shows an example of how the technologies interact or can be combined to achieve various levels of nitrogen removal or effluent TIN concentrations.

**Table 2. Example of Technology Combinations for Different Effluent TIN Targets**

TIN < 20 mg/L	TIN < 8 mg/L	TIN < 3 mg/L
Sidestream only (depending on influent nitrogen and nitrogen load in dewatering return streams)	Mainstream only	Mainstream + sidestream + tertiary
Mainstream only	Mainstream + sidestream	Tertiary only
Tertiary only		Tertiary + sidestream Mainstream + intensification + sidestream

For Brightwater, a total of 48 possible technology combination alternatives were initially developed, but only 15 were carried forward for the screening evaluation. The technology combination alternatives are shown in the base technology combination matrix in Attachment B. Alternatives 16 through 48 were considered “failed” alternatives with the following justification for failure applied to CEPT and partial granulation alternatives:

- Brightwater already has a CEPT system installed. Technology combination alternatives that include CEPT were not be scored as part of the screening evaluation. CEPT may be considered as an add-on for any of the selected alternatives if it is determined during the process modeling that carbon diversion would be beneficial or required because of capacity/footprint constraints.





- All alternatives assume Brightwater's MBR system is retained. Because of limited experience with partial granulation in an MBR configuration and uncertainties with partial granulation in a configuration without biological phosphorus removal, partial granulation was only scored for the base mainstream alternatives (i.e., MLE/MBR with partial granulation, four-stage modified Bardenpho (4SMB)/MBR with partial granulation, and SND/MBR with partial granulation).

In addition to the failed CEPT and partial granulation alternatives noted above, additional alternatives were failed and removed from consideration if the technology combination was unable to meet permit objectives or was not viable for that scenario (only applicable for Scenario 3). The following sections provide a brief overview of alternatives that were evaluated for each scenario. Refer to the tables in Attachment B for the full list of technology combination alternatives for each scenario and justification for failing certain alternatives. The screening matrices in Section 3.3 also show the failed alternatives for each scenario.

### **3.1.1 Scenario 1: SND with Sidestream Treatment**

A screening evaluation was not required for Scenario 1. The only sidestream treatment technology carried forward from the prescreening workshops is anammox.

### **3.1.2 Scenario 2: Year-Round Nitrogen Removal (8-mg/L TIN Equivalent)**

All 15 technology combination alternatives were considered in the screening evaluation for Scenario 2. None of the alternatives were failed. A complete list of the technology combination alternatives for Scenario 2 is shown on Figure 2.

### **3.1.3 Scenario 3: Year-Round Nitrogen Removal (TIN = 3 mg/L)**

A total of 12 alternatives were considered in the screening evaluation for Scenario 3. All MLE alternatives, except those with tertiary denitrifying fixed-film, were failed because MLE is not be able to meet an effluent TIN of 3 mg/L without additional tertiary treatment. A complete list of the technology combination alternatives for Scenario 3 is shown on Figure 3.

## **3.2 Screening Criteria and Weighting**

BC developed preliminary screening criteria and assigned draft weighting scores that were reviewed with the County during Workshop 1. In general, the same screening criteria that were used for the initial screening evaluation (TM 1) were retained for this analysis, with the following exceptions:

- The criterion for “scalability to large wastewater treatment plant” was removed because all technologies are scalable and would have the same ranking.
- The criterion for “truck traffic” was removed because truck traffic is not a concern for Brightwater (primarily applicable at West Point).
- The criterion for “resource recovery” was removed because the primary resource recovery benefit would be associated with the MBR technology, which is included in all the technology combination alternatives for Brightwater. The resource recovery criterion was removed because all alternatives would have similar ranking.

Weighting scores were assigned on a 1 to 3 scale, where a score of 3 represents the greatest importance to the facility. The weighting score for each criterion is multiplied by the assigned score for that criterion for each alternative to calculate a total weighted score (Section 3.3).

Table 3 summarizes the final list of screening criteria and assigned weighting scores from the workshop.

Table 3. Screening Criteria and Assigned Weighting Scores for Brightwater		
Screening criteria	Weight <sup>a</sup>	Notes or adjustments from Workshop 1
Technology status	1	Assigned a weighting score of 1 recognizing that technology status will likely change in the time between this study and actual implementation of the technologies.
Effluent nitrogen concentration	3	
Load variation impact	2	Increased weighting score from 1 to 2.
Flow variation impact	1	Decreased weighting score from 2 to 1.
Footprint	3	Assigned a weighting score of 3 because Brightwater is a footprint-constrained site (less room to build than at South Treatment Plant). It was also noted that it is extremely difficult to permit for construction in the wetlands/surrounding area.
Impacts to other processes	1	
Energy use	2	
Greenhouse gas (GHG) emissions	2	For this evaluation, GHG emissions focus on the relative difference in nitrous oxide (N <sub>2</sub> O) generation potential between nitrogen removal technologies. Other criteria for energy use and operations and maintenance (O&M) cost already include GHG emissions that would be associated with power and chemical demands. Overall GHG emissions will be evaluated for selected alternatives as part of the next phase of the project.
Capital cost <sup>6</sup>	1	Capital cost was assigned a low weighting score for this screening evaluation to avoid eliminating alternatives by cost alone, recognizing that alternatives with high capital cost may be the only feasible options for certain nitrogen removal scenarios. In addition, one of the County's objectives for this project is to determine costs of feasible options and have a range of capital costs for different nitrogen removal scenarios. Capital costs will be developed for selected alternatives as part of the life-cycle cost analysis in the next step of the project.
O&M cost	1	O&M cost was assigned a low weighting score for similar reasons as the capital cost criterion. O&M costs will be developed for selected alternatives as part of the life-cycle cost analysis in the next step of the project.
Constructability	2	Increased weighting score from 1 to 2. Some technologies, such as 4SMB, would require a difficult retrofit of the existing aeration basins that would impact Brightwater's operation during construction. The team considered a weighting score of 3 but assigned a 2 because of the ability to divert flow to South Treatment Plant during construction.
Operational complexity	3	

a. Score of 1 to 3, where 3 represents the highest weighting factor.

### 3.3 Application of Screening Criteria

The screening criteria were applied separately to each technology combination alternative. BC assigned draft scores for each criterion for each alternative before Workshop 1. Scores were adjusted based on workshop discussion. Notes from the workshop discussion are summarized below:

- For flow variation impact, the three mainstream alternatives with partial granulation were assigned a slightly higher score than alternatives without partial granulation (3 versus 2). The main benefit of partial granulation at Brightwater is the potential improved filterability, which would reduce membrane requirements (and membrane tankage).
- For alternatives that include tertiary denitrifying fixed-film technology, constructability scores were increased (changed from scores of 2 or 3 to 3 or 4) because installation location for tertiary filters is flexible and the cutover could likely be accomplished without significant issues.



- The operational complexity score for Alternative 15 was reduced (changed from a score of 2 to 1) to provide consistency with rankings of other alternatives, which were scored one point lower for alternatives that included sidestream treatment. The preliminary ranking for Alternative 15 was incorrectly assigned.
- There was a discussion regarding the impact of sidestream treatment on nitrogen loading and whether the alternatives with sidestream anammox should be scored higher than alternatives without sidestream treatment.
  - Sidestream anammox would include centrate flow equalization to provide a consistent feed to sidestream treatment with non-continuous dewatering operation. With a typical ammonia-nitrogen removal efficiency of approximately 85 percent, sidestream anammox would substantially reduce nitrogen loading to the mainstream process and eliminate spikes in nitrogen loading associated with non-continuous dewatering operation/centrate return.
  - Sidestream anammox would have a benefit on nitrogen loading impacts relative to other alternatives without sidestream anammox assuming no sidestream flow equalization (i.e., centrate returned to the mainstream process only while dewatering is online). However, the team decided that all alternatives would include sidestream flow equalization (centrate only) to reduce nitrogen loading variation caused by non-continuous dewatering operation. For alternatives without sidestream treatment, options for using the ammonia-rich centrate to even out the diurnal influent nitrogen loading could also be investigated (e.g., storing centrate during the high diurnal influent nitrogen loading period and returning centrate during the periods of lowest influent nitrogen loading). Assumptions for centrate handling for alternatives without sidestream treatment will be confirmed during the modeling in the next phase of the project.

The final scoring for each alternative is shown in the base technology combination screening matrix (Figure 1). The total weighted score for each alternative was used as the primary basis for identifying recommended alternatives to carry forward for each scenario, but alternatives with lower scores were still considered where it made sense. Figure 2 shows the final technology combination screening matrix for Scenario 2, and Figure 3 shows the final technology combination screening matrix for Scenario 3. The matrices for Scenarios 2 and 3 use the same scores as the base matrix.

		Technology combination alternatives															
		1	2	3	4	5	6	7	8	9	10	11	12	13	14	15	
Technologies	Classification																
MLE	Mainstream	✓	✓	✓	✓	✓											
4SMB	Mainstream						✓	✓	✓	✓	✓						
SND	Mainstream											✓	✓	✓	✓	✓	
Anammox	Sidestream		✓			✓		✓			✓		✓			✓	
Denitrifying fixed film	Tertiary				✓	✓				✓	✓				✓	✓	
MBR	Intensification	✓	✓	✓	✓	✓	✓	✓	✓	✓	✓	✓	✓	✓	✓	✓	
Partial granulation	Intensification			✓					✓					✓			
CEPT	Carbon diversion																
Screening criteria	Weight <sup>2</sup>	Score <sup>1</sup>															
Technology status	1	5	5	1	5	5	5	5	5	1	5	5	3	3	1	3	3
Effluent N concentration	3	3	4	3	5	5	4	5	4	5	5	4	5	4	5	5	5
Load variation impact	2	3	3	3	5	5	3	3	3	3	5	5	3	3	3	5	5
Flow variation impact	1	2	2	3	2	2	2	2	3	2	2	2	2	2	3	2	2
Footprint	3	4	5	5	3	4	3	4	4	2	3	3	4	4	4	2	3
Impacts to other processes	1	3	3	3	2	2	3	3	3	2	2	3	3	3	3	2	2
Energy use	2	2	3	2	1	2	2	3	2	1	2	4	5	4	3	4	4
GHG emissions (N <sub>2</sub> O)	2	3	3	3	3	3	3	3	3	3	3	2	2	2	2	2	2
Capital cost	1	5	4	4	3	2	3	2	2	1	1	5	4	4	4	3	2
O&M cost	1	2	3	2	1	1	2	3	2	1	1	4	5	4	3	4	4
Constructability	2	5	5	5	4	4	2	2	2	2	2	5	5	5	4	4	4
Operational complexity	3	5	4	2	4	3	5	4	2	4	3	3	2	1	2	1	1
Total un-weighted score		42	44	36	38	38	37	39	31	33	34	41	43	38	36	37	37
Total weighted score		79	84	69	75	76	71	76	61	66	68	75	80	70	68	70	70
Selected?																	

Notes:  
 1. Score of 1 to 5, where 5 represents the greatest benefit or lowest cost, footprint, emissions, etc.  
 2. Score of 1 to 3, where 3 represents the highest weighting factor.

Figure 1. Base technology combination screening matrix for Brightwater



		Technology combination alternatives															
		1	2	3	4	5	6	7	8	9	10	11	12	13	14	15	
Technologies	Classification																
MLE	Mainstream	✓	✓	✓	✓	✓											
4SMB	Mainstream						✓	✓	✓	✓	✓						
SND	Mainstream											✓	✓	✓	✓	✓	
Anammox	Sidestream		✓			✓		✓			✓		✓			✓	
Denitrifying fixed film	Tertiary				✓	✓				✓	✓				✓	✓	
MBR	Intensification	✓	✓	✓	✓	✓	✓	✓	✓	✓	✓	✓	✓	✓	✓	✓	
Partial granulation	Intensification			✓					✓					✓			
CEPT	Carbon diversion																
Screening criteria	Weight <sup>2</sup>	Score <sup>1</sup>															
Technology status	1	5	5	1	5	5	5	5	5	1	5	5	3	3	1	3	3
Effluent N concentration	3	3	4	3	5	5	4	5	4	5	5	4	5	4	5	5	5
Load variation impact	2	3	3	3	5	5	3	3	3	3	5	5	3	3	3	5	5
Flow variation impact	1	2	2	3	2	2	2	2	3	2	2	2	2	2	3	2	2
Footprint	3	4	5	5	3	4	3	4	4	2	3	3	4	4	2	3	3
Impacts to other processes	1	3	3	3	2	2	3	3	3	2	2	3	3	3	2	2	2
Energy use	2	2	3	2	1	2	2	3	2	1	2	4	5	4	3	4	4
GHG emissions (N <sub>2</sub> O)	2	3	3	3	3	3	3	3	3	3	3	2	2	2	2	2	2
Capital cost	1	5	4	4	3	2	3	2	2	1	1	5	4	4	3	2	2
O&M cost	1	2	3	2	1	1	2	3	2	1	1	4	5	4	3	4	4
Constructability	2	5	5	5	4	4	2	2	2	2	2	5	5	5	4	4	4
Operational complexity	3	5	4	2	4	3	5	4	2	4	3	3	2	1	2	1	1
Total un-weighted score		42	44	36	38	38	37	39	31	33	34	41	43	38	36	37	37
Total weighted score		79	84	69	75	76	71	76	61	66	68	75	80	70	68	70	70
Selected?		No	Yes	No	No	Yes	No	No	No	No	No	No	Yes	No	No	No	No

Notes:  
 1. Score of 1 to 5, where 5 represents the greatest benefit or lowest cost, footprint, emissions, etc.  
 2. Score of 1 to 3, where 3 represents the highest weighting factor.

Figure 2. Technology combination screening matrix for Brightwater Scenario 2 (year-round nitrogen removal [8-mg/L TIN equivalent])



		Technology combination alternatives														
		1	2	3	4	5	6	7	8	9	10	11	12	13	14	15
Technologies	Classification															
MLE	Mainstream	✓	✓	✓	✓	✓										
4SMB	Mainstream						✓	✓	✓	✓	✓					
SND	Mainstream											✓	✓	✓	✓	✓
Anammox	Sidestream		✓			✓		✓			✓		✓			✓
Denitrifying fixed film	Tertiary				✓	✓				✓	✓				✓	✓
MBR	Intensification	✓	✓	✓	✓	✓	✓	✓	✓	✓	✓	✓	✓	✓	✓	✓
Partial granulation	Intensification			✓					✓					✓		
CEPT	Carbon diversion															
Screening criteria	Weight <sup>2</sup>	Score <sup>1</sup>														
Technology status	1				5	5	5	5	1	5	5	3	3	1	3	3
Effluent N concentration	3				5	5	4	5	4	5	5	4	5	4	5	5
Load variation impact	2				5	5	3	3	3	5	5	3	3	3	5	5
Flow variation impact	1				2	2	2	2	3	2	2	2	2	3	2	2
Footprint	3				3	4	3	4	4	2	3	3	4	4	2	3
Impacts to other processes	1				2	2	3	3	3	2	2	3	3	3	2	2
Energy use	2				1	2	2	3	2	1	2	4	5	4	3	4
GHG emissions (N <sub>2</sub> O)	2				3	3	3	3	3	3	3	2	2	2	2	2
Capital cost	1				3	2	3	2	2	1	1	5	4	4	3	2
O&M cost	1				1	1	2	3	2	1	1	4	5	4	3	4
Constructability	2				4	4	2	2	2	2	2	5	5	5	4	4
Operational complexity	3				4	3	5	4	2	4	3	3	2	1	2	1
Total un-weighted score		Fail	Fail	Fail	38	38	37	39	31	33	34	41	43	38	36	37
Total weighted score		Fail	Fail	Fail	75	76	71	76	61	66	68	75	80	70	68	70
Selected?		No	No	No	No	Yes	No	Yes	No	No	No	No	Yes	No	No	No

Notes:

1. Score of 1 to 5, where 5 represents the greatest benefit or lowest cost, footprint, emissions, etc.

2. Score of 1 to 3, where 3 represents the highest weighting factor.

Figure 3. Technology combination screening matrix for Brightwater Scenario 3 (year-round nitrogen removal [TIN = 3 mg/L])



### 3.4 Results of Screening Evaluation

This section summarizes the results of the screening evaluation for each scenario.

#### 3.4.1 Scenario 1: SND with Sidestream Treatment

Sidestream anammox was selected without a full screening because it is the only remaining sidestream treatment technology. Sidestream anammox will be evaluated as an add-on to the BWABO-SND upgrade.

#### 3.4.2 Scenario 2: Year-Round Nitrogen Removal (8-mg/L TIN Equivalent)

Table 4 shows the total weighted scores from the workshop and selected alternatives for Scenario 2. The two alternatives with the highest total weighted scores, MLE/MBR with sidestream anammox and SND/MBR with sidestream anammox, were selected for detailed evaluation. The SND/MBR alternative will build upon the BWABO-SND modeling from Scenario 1 and determine required modifications to achieve the year-round equivalent effluent TIN target of 8 mg/L at the selected design flows/loads. MLE/MBR with sidestream anammox will be based on reconfiguring the existing MLE/MBR process with optimally sized anoxic volume and IMLR pumping, including external carbon addition if required.

Alternative	Description	Total weighted score	Selected?
2	MLE/MBR + sidestream anammox	84	Yes
12	SND/MBR + sidestream anammox	80	Yes
1	MLE/MBR	79	No
5	MLE/MBR + tertiary denitrifying fixed-film + sidestream anammox	76	Yes
7	4SMB/MBR + sidestream anammox	76	No
4	MLE/MBR + tertiary denitrifying fixed-film	75	No
11	SND/MBR	75	No
6	4SMB/MBR	71	No
13	SND/MBR + partial granulation	70	No
15	SND/MBR + tertiary denitrifying fixed-film + sidestream anammox	70	No
3	MLE/MBR + partial granulation	69	No
10	4SMB/MBR + tertiary denitrifying fixed-film + sidestream anammox	68	No
14	SND/MBR + tertiary denitrifying fixed-film	68	No
9	4SMB/MBR + tertiary denitrifying fixed-film	66	No
8	4SMB/MBR + partial granulation	61	No

a. Alternatives are sorted by highest total weighted score. Failed alternatives are not shown.

MLE/MBR without sidestream treatment (Alternative 1) was not carried forward based on workshop discussion regarding Brightwater's existing carbon limitations, where preliminary modeling for the BWABO project had indicated that MLE alone would likely not be able to achieve an effluent TIN of 8 mg/L. Therefore, sidestream anammox should be included with an MLE/MBR alternative.

Alternative 5, MLE/MBR with sidestream anammox and a tertiary denitrifying fixed-film process, was selected as the third alternative to carry forward. Because this alternative includes both mainstream and tertiary nitrogen removal processes, it offers more flexibility for selecting the extent of modifications to Brightwater's existing MLE/MBR configuration and for balancing external carbon demands between the

mainstream and tertiary processes. For example, the MLE/MBR process could be fully optimized to maximize mainstream nitrogen removal and alkalinity recovery (as in Alternative 2) and minimize required tertiary nitrogen removal, or the MLE/MBR process could be configured based on minimizing required modifications to Brightwater’s existing aeration basins and relying more on the tertiary nitrogen removal process to achieve effluent targets. The preferred approach will need to be defined during the modeling in the next phase of the project.

### 3.4.3 Scenario 3: Year-Round Nitrogen Removal (TIN = 3 mg/L)

Table 5 shows the total weighted scores from the workshop and selected alternatives for Scenario 3. The three alternatives with the highest total weighted scores were selected for detailed evaluation. For SND/MBR with sidestream anammox (Alternative 12), SND would be optimally sized to achieve a year-round effluent TIN of 3 mg/L at the selected design flows/loads, if possible. Process modeling will be used to determine the feasibility of achieving a year-round effluent TIN of 3 mg/L with SND at Brightwater (there are other existing facilities that achieve TIN less than 3 mg/L).

Alternative	Description	Total weighted score	Selected?
12	SND/MBR + sidestream anammox	80	Yes
5	MLE/MBR + tertiary denitrifying fixed-film + sidestream anammox	76	Yes
7	4SMB/MBR + sidestream anammox	76	Yes
4	MLE/MBR + tertiary denitrifying fixed-film	75	No
11	SND/MBR	75	No
6	4SMB/MBR	71	No
13	SND/MBR + partial granulation	70	No
15	SND/MBR + tertiary denitrifying fixed-film + sidestream anammox	70	No
10	4SMB/MBR + tertiary denitrifying fixed-film + sidestream anammox	68	No
14	SND/MBR + tertiary denitrifying fixed-film	68	No
9	4SMB/MBR + tertiary denitrifying fixed-film	66	No
8	4SMB/MBR + partial granulation	61	No

*a. Alternatives are sorted by highest total weighted score. Failed alternatives are not shown.*

For MLE/MBR with sidestream anammox and a tertiary denitrifying fixed-film process (Alternative 5), the approach for configuring the mainstream and tertiary nitrogen removal processes will need to be confirmed as described above for Scenario 2. However, compared to Scenario 2, additional nitrogen removal will be required in the tertiary process because of the lower effluent TIN limit for Scenario 3. The final selected alternative for Scenario 3 was 4SMB/MBR with sidestream anammox (Alternative 7). The 4SMB option will require significant retrofits to Brightwater’s existing aeration basins but may be required to reliably achieve TIN less than 3 mg/L in the mainstream process. It will provide another data point for the County for evaluating costs of feasible options for a low year-round effluent TIN scenario.



### 3.5 Summary of Selected Alternatives

Table 6 summarizes the selected alternatives for each scenario and identifies the alternative numbering that will be used during the next phase of the project (e.g., Alternatives 1A, 2A, 2B, etc.). As shown, an SND/MBR alternative will be evaluated for each of the three scenarios. The team agreed during the workshop that SND should be considered for each scenario because it aligns well with the current BWABO SND project. It is likely that the SND modeling for this nitrogen removal study will parallel or follow updated SND modeling for the BWABO project.

<b>Table 6. Summary of Selected Alternatives for Brightwater Nitrogen Removal Scenarios<sup>a</sup></b>	
<b>Alternative</b>	<b>Description</b>
<b>Scenario 1: SND with sidestream treatment</b>	
1A	SND/MBR + sidestream anammox
<b>Scenario 2: Year-round N removal, 8-mg/L TIN equivalent</b>	
2A	SND/MBR + sidestream anammox
2B	MLE/MBR + sidestream anammox
2C	MLE/MBR + tertiary denitrifying fixed-film + sidestream anammox
<b>Scenario 3: Year-round N removal, effluent TIN limit of 3 mg/L</b>	
3A	SND/MBR + sidestream anammox
3B	4SMB/MBR + sidestream anammox
3C	MLE/MBR + tertiary denitrifying fixed-film + sidestream anammox

*a. Brightwater already has a CEPT system installed. CEPT may be considered as an add-on for any of the selected alternatives if it is determined during the process modeling that carbon diversion would be beneficial or required because of capacity/footprint constraints.*

## Section 4: Next Steps

The selected alternatives for Brightwater will be modeled and sized. The preliminary modeling results will be reviewed with the County before developing layouts, costs, and GHG emissions estimates. BC recommends scheduling a modeling review meeting/conference call for September 2019. The option to add a fourth nitrogen removal scenario for Brightwater may also be discussed as part of the modeling review check-in.

## **Attachment A: Meeting Notes from Nitrogen Effluent Limit Conference Call**

---

# Meeting Notes

**Prepared for:** King County Wastewater Treatment Division

**Project Title:** Nitrogen (N) Removal Analysis

**Contract No.:** 1170-17 VLN

**Meeting Name:** Nitrogen Effluent Limit Discussion Conference Call

**Meeting Location:** Brightwater, Little Bear Creek Conference Room; South Plant, Black River Conference Room; West Point, Mt. Rainier Conference Room (or Skype)

**Meeting Date:** April 24, 2019

**Meeting Time:** 10:00 am to 11:30 am

**Purpose:** Discuss and select up to four effluent nitrogen conditions for each plant to be used as the basis for evaluation.

Invitees:	<u>Consultant Team:</u>	<u>King County:</u>	
	Rick Kelly (BC) Matt Winkler (BC) Patricia Tam (BC)	Eron Jacobson Tiffany Knapp John Conway Matthew Nolan Rick Butler Bob Bucher Eugene Sugita Jessica Tanumihardja Al Williamson Mike Wohlfert Jacque Klug Sally Gordon Tushar Khurana Jeff Lafer Robert Edsforth	Andy Strehler Carol Nelson Bob Bucher Karla Guevarra <del>Rebecca Gauff</del> Bruce Nairn Truong Phuong Tom Bauer Curtis Steinke Jeff Fugier Scott Drennen Steve Huang <del>Henry Campbell</del> Sue Meyer Carl Grodnik

## Notes

---

- Considerations for selecting four conditions at each plant:
  - Create a range of removal levels to help develop cost curves
  - Develop most cost effective options at each plant
  - Identify limits for each plant where costs increase significantly
  - Include likely concentrations limits as demonstrated by DoE's Bounding Scenarios (especially lowest limit(s))
  - Develop a range of removal levels for each plant to have data to support bubble/umbrella permit scenarios
  - Consider cap mentioned in DoE AKART response
- West Point Limits / Modifications
  1. Side stream treatment, year round (assuming it can fit on site)
  2. Lowest removal level possible, year-round, maintaining existing plant capacity
  3. Lowest removal level possible, seasonal, maintaining same plant capacity
  4. 8 mg/L, year-round, identify the reduced capacity of the plant
  - Notes:

- For #4, may need to consider changes to permitting and West Point operations, depending on the secondary capacity remaining at the plant with the proposed additions of nutrient removal
  - It was noted that the significant amount of snowmelt this year led to abnormally low influent temperature at West Point (less than 8-9 deg C). This will need to be incorporated into the evaluation for winter scenarios.
- South Plant Limits / Modifications
  1. Side stream treatment, year round, nitrification/de-nitrification during summer with existing infrastructure
  2. 3 mg/L, year-round
  3. 8 mg/L equivalent, year-round, most cost-effective approach (e.g. 5 mg/L summer and 12 mg/L winter)
  4. 8 mg/L, seasonally
  - Notes:
    - Potential to switch between N removal in summer and bio-P in winter, similar to current operation when nitrifying in summer
    - The option to try to maximize N removal with existing basins (i.e. relocate baffles, add IMLR pumps, and/or add carbon addition) was deemed to provide less information that determining the optimal configuration to achieve a given concentration. A review of necessary modifications to existing tanks and other infrastructure could then be evaluated to meet the optimal configuration.
- Brightwater Limits / Modifications
  1. 3 mg/L, year-round
  2. 8 mg/L equivalent, year-round, most cost-effective approach (e.g. 5 mg/L summer and 12 mg/L winter)
  3. Side-stream treatment with Brightwater Aeration Basin Optimization (BWABO) upgrades assumed to be complete including Simultaneous Nitrification Denitrification (SND)
  4. Left open for now
  - Notes:
    - Nitrogen removal from SND needs to be modeled in greater detail. Performance is uncertain because of the differences compared to other operating SND facilities (lower temperatures, membrane application, etc.)
    - While BW could potentially take more flow, from SP for example, and potentially remove more N more cost effectively, this analysis goes beyond the scope of the project. Ultimately, this configuration should be considered once permit requirements are better understood (along with other flow redistribution configurations).
    - Brightwater has planned expansion for Aeration Basin #4. Consider the expansion when developing various technologies and the associated removal limits and strategies.

## **Attachment B: Technology Combinations**

---



Base technology combination matrix											
Technology combination alternatives	Description	Mainstream			Sidestream	Tertiary	Intensification		Carbon diversion	Pass/Fail	Justification for failure
		MLE	4SMB	SND	Anammox	Denitrifying fixed film	MBR	Partial granulation	CEPT		
1	MLE/MBR	✓					✓			Pass	
2	MLE/MBR + sidestream anammox	✓			✓		✓			Pass	
3	MLE/MBR + partial granulation	✓					✓	✓		Pass	
4	MLE/MBR + tertiary denitrifying fixed-film	✓				✓	✓			Pass	
5	MLE/MBR + tertiary denitrifying fixed-film + sidestream anammox	✓			✓	✓	✓			Pass	
6	4SMB/MBR		✓				✓			Pass	
7	4SMB/MBR + sidestream anammox		✓		✓		✓			Pass	
8	4SMB/MBR + partial granulation		✓				✓	✓		Pass	
9	4SMB/MBR + tertiary denitrifying fixed-film		✓			✓	✓			Pass	
10	4SMB/MBR + tertiary denitrifying fixed-film + sidestream anammox		✓		✓	✓	✓			Pass	
11	SND/MBR			✓			✓			Pass	
12	SND/MBR + sidestream anammox			✓	✓		✓			Pass	
13	SND/MBR + partial granulation			✓			✓	✓		Pass	
14	SND/MBR + tertiary denitrifying fixed-film			✓		✓	✓			Pass	
15	SND/MBR + tertiary denitrifying fixed-film + sidestream anammox			✓	✓	✓	✓			Pass	
16	MLE/MBR + CEPT	✓					✓		✓	Fail	Brightwater already has a CEPT system installed. Technology combination alternatives that include CEPT will not be scored as part of the weighted screening criteria evaluation. CEPT may be considered as an add-on for any of the selected alternatives if it is determined during the process modeling that carbon diversion would be beneficial or required because of capacity/footprint constraints. All alternatives assume Brightwater's MBR system is retained. Because of limited experience with partial granulation in an MBR configuration, partial granulation will only be scored for the base mainstream alternatives: MLE/MBR + partial granulation, 4SMB/MBR + partial granulation, and SND/MBR + partial granulation.
17	MLE/MBR + CEPT + sidestream anammox	✓			✓		✓		✓	Fail	
18	MLE/MBR + partial granulation + sidestream anammox	✓			✓		✓	✓		Fail	
19	MLE/MBR + partial granulation + CEPT	✓					✓	✓	✓	Fail	
20	MLE/MBR + CEPT + tertiary denitrifying fixed-film	✓				✓	✓		✓	Fail	
21	MLE/MBR + partial granulation + tertiary denitrifying fixed-film	✓				✓	✓	✓		Fail	
22	MLE/MBR + partial granulation + CEPT + sidestream anammox	✓			✓		✓	✓	✓	Fail	
23	MLE/MBR + CEPT + tertiary denitrifying fixed-film + sidestream anammox	✓			✓	✓	✓		✓	Fail	
24	MLE/MBR + partial granulation + CEPT + tertiary denitrifying fixed-film	✓				✓	✓	✓	✓	Fail	
25	MLE/MBR + partial granulation + tertiary denitrifying fixed-film + sidestream anammox	✓			✓	✓	✓	✓		Fail	
26	MLE/MBR + partial granulation + CEPT + tertiary denitrifying fixed-film + sidestream anammox	✓			✓	✓	✓	✓	✓	Fail	
27	4SMB/MBR + CEPT		✓				✓		✓	Fail	
28	4SMB/MBR + CEPT + sidestream anammox		✓		✓		✓		✓	Fail	
29	4SMB/MBR + partial granulation + sidestream anammox		✓		✓		✓	✓		Fail	
30	4SMB/MBR + partial granulation + CEPT		✓				✓	✓	✓	Fail	
31	4SMB/MBR + CEPT + tertiary denitrifying fixed-film		✓			✓	✓		✓	Fail	
32	4SMB/MBR + partial granulation + tertiary denitrifying fixed-film		✓			✓	✓	✓		Fail	
33	4SMB/MBR + partial granulation + CEPT + sidestream anammox		✓		✓		✓	✓	✓	Fail	
34	4SMB/MBR + CEPT + tertiary denitrifying fixed-film + sidestream anammox		✓		✓	✓	✓		✓	Fail	
35	4SMB/MBR + partial granulation + CEPT + tertiary denitrifying fixed-film		✓			✓	✓	✓	✓	Fail	
36	4SMB/MBR + partial granulation + tertiary denitrifying fixed-film + sidestream anammox		✓		✓	✓	✓	✓		Fail	
37	4SMB/MBR + partial granulation + CEPT + tertiary denitrifying fixed-film + sidestream anammox		✓		✓	✓	✓	✓	✓	Fail	
38	SND/MBR + CEPT			✓			✓		✓	Fail	
39	SND/MBR + CEPT + sidestream anammox			✓	✓		✓		✓	Fail	
40	SND/MBR + partial granulation + sidestream anammox			✓	✓		✓	✓		Fail	
41	SND/MBR + partial granulation + CEPT			✓			✓	✓	✓	Fail	
42	SND/MBR + CEPT + tertiary denitrifying fixed-film			✓		✓	✓		✓	Fail	
43	SND/MBR + partial granulation + tertiary denitrifying fixed-film			✓		✓	✓	✓		Fail	
44	SND/MBR + partial granulation + CEPT + sidestream anammox			✓	✓		✓	✓	✓	Fail	
45	SND/MBR + CEPT + tertiary denitrifying fixed-film + sidestream anammox			✓	✓	✓	✓		✓	Fail	
46	SND/MBR + partial granulation + CEPT + tertiary denitrifying fixed-film			✓		✓	✓	✓	✓	Fail	
47	SND/MBR + partial granulation + tertiary denitrifying fixed-film + sidestream anammox			✓	✓	✓	✓	✓		Fail	
48	SND/MBR + partial granulation + CEPT + tertiary denitrifying fixed-film + sidestream anammox			✓	✓	✓	✓	✓	✓	Fail	

Scenario 2: Year-round N removal, 8-mg/L TIN equivalent												
Technology combination alternatives	Description	Mainstream			Sidestream	Tertiary	Intensification		Carbon diversion	Pass/Fail	Justification for failure	
		MLE	4SMB	SND	Anammox	Denitrifying fixed film	MBR	Partial granulation	CEPT			
1	MLE/MBR	✓					✓			Pass		
2	MLE/MBR + sidestream anammox	✓			✓		✓			Pass		
3	MLE/MBR + partial granulation	✓					✓	✓		Pass		
4	MLE/MBR + tertiary denitrifying fixed-film	✓				✓	✓			Pass		
5	MLE/MBR + tertiary denitrifying fixed-film + sidestream anammox	✓			✓	✓	✓			Pass		
6	4SMB/MBR		✓				✓			Pass		
7	4SMB/MBR + sidestream anammox		✓		✓		✓			Pass		
8	4SMB/MBR + partial granulation		✓				✓	✓		Pass		
9	4SMB/MBR + tertiary denitrifying fixed-film		✓			✓	✓			Pass		
10	4SMB/MBR + tertiary denitrifying fixed-film + sidestream anammox		✓		✓	✓	✓			Pass		
11	SND/MBR			✓			✓			Pass		
12	SND/MBR + sidestream anammox			✓	✓		✓			Pass		
13	SND/MBR + partial granulation			✓			✓	✓		Pass		
14	SND/MBR + tertiary denitrifying fixed-film			✓		✓	✓			Pass		
15	SND/MBR + tertiary denitrifying fixed-film + sidestream anammox			✓	✓	✓	✓			Pass		
16	MLE/MBR + CEPT	✓					✓		✓	Fail	Brightwater already has a CEPT system installed. Technology combination alternatives that include CEPT will not be scored as part of the weighted screening criteria evaluation. CEPT may be considered as an add-on for any of the selected alternatives if it is determined during the process modeling that carbon diversion would be beneficial or required because of capacity/footprint constraints. All alternatives assume Brightwater's MBR system is retained. Because of limited experience with partial granulation in an MBR configuration, partial granulation will only be scored for the base mainstream alternatives: MLE/MBR + partial granulation, 4SMB/MBR + partial granulation, and SND/MBR + partial granulation.	
17	MLE/MBR + CEPT + sidestream anammox	✓			✓		✓		✓	Fail		
18	MLE/MBR + partial granulation + sidestream anammox	✓			✓		✓	✓		Fail		
19	MLE/MBR + partial granulation + CEPT	✓					✓	✓	✓	Fail		
20	MLE/MBR + CEPT + tertiary denitrifying fixed-film	✓				✓	✓		✓	Fail		
21	MLE/MBR + partial granulation + tertiary denitrifying fixed-film	✓				✓	✓	✓		Fail		
22	MLE/MBR + partial granulation + CEPT + sidestream anammox	✓			✓		✓	✓	✓	Fail		
23	MLE/MBR + CEPT + tertiary denitrifying fixed-film + sidestream anammox	✓			✓	✓	✓		✓	Fail		
24	MLE/MBR + partial granulation + CEPT + tertiary denitrifying fixed-film	✓				✓	✓	✓	✓	Fail		
25	MLE/MBR + partial granulation + tertiary denitrifying fixed-film + sidestream anammox	✓			✓	✓	✓	✓		Fail		
26	MLE/MBR + partial granulation + CEPT + tertiary denitrifying fixed-film + sidestream anammox	✓			✓	✓	✓	✓	✓	Fail		
27	4SMB/MBR + CEPT		✓				✓		✓	Fail		
28	4SMB/MBR + CEPT + sidestream anammox		✓		✓		✓		✓	Fail		
29	4SMB/MBR + partial granulation + sidestream anammox		✓		✓		✓	✓		Fail		
30	4SMB/MBR + partial granulation + CEPT		✓				✓	✓	✓	Fail		
31	4SMB/MBR + CEPT + tertiary denitrifying fixed-film		✓			✓	✓		✓	Fail		
32	4SMB/MBR + partial granulation + tertiary denitrifying fixed-film		✓			✓	✓	✓		Fail		
33	4SMB/MBR + partial granulation + CEPT + sidestream anammox		✓		✓		✓	✓	✓	Fail		
34	4SMB/MBR + CEPT + tertiary denitrifying fixed-film + sidestream anammox		✓		✓	✓	✓		✓	Fail		
35	4SMB/MBR + partial granulation + CEPT + tertiary denitrifying fixed-film		✓			✓	✓	✓	✓	Fail		
36	4SMB/MBR + partial granulation + tertiary denitrifying fixed-film + sidestream anammox		✓		✓	✓	✓	✓		Fail		
37	4SMB/MBR + partial granulation + CEPT + tertiary denitrifying fixed-film + sidestream anammox		✓		✓	✓	✓	✓	✓	Fail		
38	SND/MBR + CEPT			✓			✓		✓	Fail		
39	SND/MBR + CEPT + sidestream anammox			✓	✓		✓		✓	Fail		
40	SND/MBR + partial granulation + sidestream anammox			✓	✓		✓	✓		Fail		
41	SND/MBR + partial granulation + CEPT			✓			✓	✓	✓	Fail		
42	SND/MBR + CEPT + tertiary denitrifying fixed-film			✓		✓	✓		✓	Fail		
43	SND/MBR + partial granulation + tertiary denitrifying fixed-film			✓		✓	✓	✓		Fail		
44	SND/MBR + partial granulation + CEPT + sidestream anammox			✓	✓		✓	✓	✓	Fail		
45	SND/MBR + CEPT + tertiary denitrifying fixed-film + sidestream anammox			✓	✓	✓	✓		✓	Fail		
46	SND/MBR + partial granulation + CEPT + tertiary denitrifying fixed-film			✓		✓	✓	✓	✓	Fail		
47	SND/MBR + partial granulation + tertiary denitrifying fixed-film + sidestream anammox			✓	✓	✓	✓	✓		Fail		
48	SND/MBR + partial granulation + CEPT + tertiary denitrifying fixed-film + sidestream anammox			✓	✓	✓	✓	✓	✓	Fail		

Scenario 3: Year-round N removal, effluent TIN limit of 3 mg/L

Technology combination alternatives	Description	Mainstream			Sidestream	Tertiary	Intensification		Carbon diversion	Pass/Fail	Justification for failure
		MLE	4SMB	SND	Anammox	Denitrifying fixed film	MBR	Partial granulation	CEPT		
1	MLE/MBR	✓					✓			Fail	Unlikely to be able to meet TIN limit of 3 mg/L.
2	MLE/MBR + sidestream anammox	✓			✓		✓			Fail	
3	MLE/MBR + partial granulation	✓					✓	✓		Fail	
4	MLE/MBR + tertiary denitrifying fixed-film	✓				✓	✓			Pass	
5	MLE/MBR + tertiary denitrifying fixed-film + sidestream anammox	✓			✓	✓	✓			Pass	
6	4SMB/MBR		✓				✓			Pass	
7	4SMB/MBR + sidestream anammox		✓		✓		✓			Pass	
8	4SMB/MBR + partial granulation		✓				✓	✓		Pass	
9	4SMB/MBR + tertiary denitrifying fixed-film		✓			✓	✓			Pass	
10	4SMB/MBR + tertiary denitrifying fixed-film + sidestream anammox		✓		✓	✓	✓			Pass	
11	SND/MBR			✓			✓			Pass	
12	SND/MBR + sidestream anammox			✓	✓		✓			Pass	
13	SND/MBR + partial granulation			✓			✓	✓		Pass	
14	SND/MBR + tertiary denitrifying fixed-film			✓		✓	✓			Pass	
15	SND/MBR + tertiary denitrifying fixed-film + sidestream anammox			✓	✓	✓	✓			Pass	
16	MLE/MBR + CEPT	✓					✓		✓	Fail	Brightwater already has a CEPT system installed. Technology combination alternatives that include CEPT will not be scored as part of the weighted screening criteria evaluation. CEPT may be considered as an add-on for any of the selected alternatives if it is determined during the process modeling that carbon diversion would be beneficial or required because of capacity/footprint constraints. All alternatives assume Brightwater's MBR system is retained. Because of limited experience with partial granulation in an MBR configuration, partial granulation will only be scored for the base mainstream alternatives: MLE/MBR + partial granulation, 4SMB/MBR + partial granulation, and SND/MBR + partial granulation.
17	MLE/MBR + CEPT + sidestream anammox	✓			✓		✓		✓	Fail	
18	MLE/MBR + partial granulation + sidestream anammox	✓			✓		✓	✓		Fail	
19	MLE/MBR + partial granulation + CEPT	✓					✓	✓	✓	Fail	
20	MLE/MBR + CEPT + tertiary denitrifying fixed-film	✓				✓	✓		✓	Fail	
21	MLE/MBR + partial granulation + tertiary denitrifying fixed-film	✓				✓	✓	✓		Fail	
22	MLE/MBR + partial granulation + CEPT + sidestream anammox	✓			✓		✓	✓	✓	Fail	
23	MLE/MBR + CEPT + tertiary denitrifying fixed-film + sidestream anammox	✓			✓	✓	✓		✓	Fail	
24	MLE/MBR + partial granulation + CEPT + tertiary denitrifying fixed-film	✓				✓	✓	✓	✓	Fail	
25	MLE/MBR + partial granulation + tertiary denitrifying fixed-film + sidestream anammox	✓			✓	✓	✓	✓		Fail	
26	MLE/MBR + partial granulation + CEPT + tertiary denitrifying fixed-film + sidestream anammox	✓			✓	✓	✓	✓	✓	Fail	
27	4SMB/MBR + CEPT		✓				✓		✓	Fail	
28	4SMB/MBR + CEPT + sidestream anammox		✓		✓		✓		✓	Fail	
29	4SMB/MBR + partial granulation + sidestream anammox		✓		✓		✓	✓		Fail	
30	4SMB/MBR + partial granulation + CEPT		✓				✓	✓	✓	Fail	
31	4SMB/MBR + CEPT + tertiary denitrifying fixed-film		✓			✓	✓		✓	Fail	
32	4SMB/MBR + partial granulation + tertiary denitrifying fixed-film		✓			✓	✓	✓		Fail	
33	4SMB/MBR + partial granulation + CEPT + sidestream anammox		✓		✓		✓	✓	✓	Fail	
34	4SMB/MBR + CEPT + tertiary denitrifying fixed-film + sidestream anammox		✓		✓	✓	✓		✓	Fail	
35	4SMB/MBR + partial granulation + CEPT + tertiary denitrifying fixed-film		✓			✓	✓	✓	✓	Fail	
36	4SMB/MBR + partial granulation + tertiary denitrifying fixed-film + sidestream anammox		✓		✓	✓	✓	✓		Fail	
37	4SMB/MBR + partial granulation + CEPT + tertiary denitrifying fixed-film + sidestream anammox		✓		✓	✓	✓	✓	✓	Fail	
38	SND/MBR + CEPT			✓			✓		✓	Fail	
39	SND/MBR + CEPT + sidestream anammox			✓	✓		✓		✓	Fail	
40	SND/MBR + partial granulation + sidestream anammox			✓	✓		✓	✓		Fail	
41	SND/MBR + partial granulation + CEPT			✓			✓	✓	✓	Fail	
42	SND/MBR + CEPT + tertiary denitrifying fixed-film			✓		✓	✓		✓	Fail	
43	SND/MBR + partial granulation + tertiary denitrifying fixed-film			✓		✓	✓	✓		Fail	
44	SND/MBR + partial granulation + CEPT + sidestream anammox			✓	✓		✓	✓	✓	Fail	
45	SND/MBR + CEPT + tertiary denitrifying fixed-film + sidestream anammox			✓	✓	✓	✓		✓	Fail	
46	SND/MBR + partial granulation + CEPT + tertiary denitrifying fixed-film			✓		✓	✓	✓	✓	Fail	
47	SND/MBR + partial granulation + tertiary denitrifying fixed-film + sidestream anammox			✓	✓	✓	✓	✓		Fail	
48	SND/MBR + partial granulation + CEPT + tertiary denitrifying fixed-film + sidestream anammox			✓	✓	✓	✓	✓	✓	Fail	



## Appendix E: TM 3A—West Point

---

This page intentionally left blank.



# Technical Memorandum

701 Pike Street, Suite 1200  
Seattle, WA 98101-2310

Phone: 206-624-0100  
Fax: 206-749-2200

Prepared for: King County

Project Title: King County Flows and Loads—Nitrogen Removal Study

Project No.: 151084.464

## Technical Memorandum 3A

Subject: West Point Site-Specific Nitrogen Removal Analysis of Planning Alternatives

Date: September 9, 2020

To: Eron Jacobson, King County Nitrogen Removal Task Lead

From: Rick Kelly, Brown and Caldwell Nitrogen Removal Task Lead

Prepared by:

Patricia Tam, P.E., WA License. No. 35722, Expiration 9/10/2021

Matt Winkler, P.E., WA License. No. 52196, Expiration 3/4/2021

Reviewed by:

Richard Kelly, Ph.D., P.E., WA License. No. 45235, Expiration 6/3/2021

*This document was prepared solely for King County in accordance with professional standards at the time the services were performed and in accordance with the contract between King County and Brown and Caldwell dated August 1, 2017. This document is governed by the specific scope of work authorized by King County; it is not intended to be relied upon by any other party except for regulatory authorities contemplated by the scope of work. We have relied on information or instructions provided by King County and other parties and, unless otherwise expressly indicated, have made no independent investigation as to the validity, completeness, or accuracy of such information.*

# Table of Contents

Section 1: Introduction .....	1
Section 2: Basis of Analysis and Assumptions .....	1
Section 3: Discussion of Alternatives .....	4
3.1 Scenario 1 – Sidestream Treatment Only .....	5
3.1.1 Alternative 1 – Existing Mainstream + Sidestream Anammox .....	5
3.2 Scenario 2 – Year-round Nitrogen Removal with Lowest Effluent TIN Possible while Maintaining Existing Secondary Treatment Capacity .....	7
3.2.1 Alternative 2A – MLE/MBR .....	7
3.2.2 Alternative 2B – MLE/MBR + Sidestream Anammox .....	10
3.2.3 Alternative 2C – 4SMB/MBR + Sidestream Anammox.....	11
3.3 Scenario 3 – Seasonal Nitrogen Removal with Lowest Effluent TIN Possible while Maintaining Existing Secondary Treatment Capacity .....	13
3.3.1 Alternative 3A – MLE/MBR + Sidestream Anammox.....	13
3.3.2 Alternative 3D – 4SMB/MBR + Sidestream Anammox .....	16
3.4 Scenario 4 – Year-round Nitrogen Removal with Effluent TIN of 8 mg/L and Reduced Secondary Treatment Capacity .....	17
3.4.1 Alternative 4A – MLE .....	17
3.4.2 Alternative 4C – MLE + Sidestream Bioaugmentation .....	20
3.4.3 Alternative 4D – 4SMB + Sidestream Anammox .....	22
3.4.4 Alternative 4E – 4SMB + Sidestream Bioaugmentation.....	23
Section 4: Cost Analysis .....	25
4.1 Capital Costs .....	25
4.1.1 Site-Specific Capital Cost Assumptions.....	25
4.1.2 Summary of Capital Costs.....	26
4.2 O&M Costs.....	28
4.2.1 Site-Specific O&M Cost Assumptions .....	28
4.2.2 Summary of O&M Costs .....	28
4.3 Life–Cycle Costs .....	29
Section 5: Comparison and Ranking of Alternatives.....	29
5.1 Evaluation Criteria and Weighting .....	29
5.1.1 Technology Status .....	30
5.1.2 Effluent Nitrogen Load Reduction .....	30
5.1.3 Load Variation Impact .....	30
5.1.4 Flow Variation Impact.....	30
5.1.5 Space for Future Expansion.....	30
5.1.5 Impacts to Other Processes.....	30
5.1.6 Truck Traffic .....	30
5.1.7 GHG Emissions .....	30



5.1.8 Resource Recovery .....31

5.1.9 CEC and Toxics Removal Potential .....31

5.1.10 Capital Cost.....31

5.1.11 O&M Cost.....31

5.1.12 Supplementary Carbon Source Flexibility .....31

5.1.13 Risks.....32

5.1.14 Constructability.....32

5.1.15 Operational Complexity .....32

5.2 Evaluation Results .....33

Section 6: Summary .....36

Attachment A: Site Layouts .....A-1

Attachment B: Greenhouse Gas Emissions Results and Literature Review of Nitrous Oxide Emission Factors  
.....B-1

Attachment C: Basis of Capital Cost Estimates of Alternatives.....C-1

Attachment D: Budgetary Proposals for Equipment .....D-1

Attachment E: Scenario 4 Alternatives Cost Analysis and Evaluation Results.....E-1

## List of Figures

---

Figure 1. Process flow schematic for Alternative 1 – existing mainstream + sidestream anammox.....6

Figure 2. Process flow schematic for Alternative 2A – MLE/MBR .....8

Figure 3. Process flow schematic for Alternative 2B – MLE/MBR + sidestream anammox.....10

Figure 4. Process flow schematic for Alternative 2C – 4SMB/MBR + sidestream anammox .....12

Figure 5. Process flow schematic for Alternative 3A – MLE/MBR + sidestream anammox .....14

Figure 6. Process flow schematic for Alternative 3D – 4SMB/MBR + sidestream anammox.....16

Figure 7. Process flow schematic for Alternative 4A – MLE .....18

Figure 8. Process flow schematic for Alternative 4C – MLE + sidestream bioaugmentation .....20

Figure 9. Process flow schematic for Alternative 4D – 4SMB + sidestream anammox.....22

Figure 10. Process flow schematic for Alternative 4E – 4SMB + sidestream bioaugmentation .....23

Figure 11. Comparison of estimated GHG emissions (scenarios 1 through 3) .....33

Figure 12. Comparison of alternatives—scoring results (scenarios 1 through 3).....35

## List of Tables

Table 1. West Point Design Flows and Loadings for Nitrogen Removal Analysis.....	2
Table 2. Summary of Selected Alternatives for West Point Nitrogen Removal Scenarios.....	4
Table 3. West Point Nitrogen Removal Modeling Results and System Sizing for Alternative 1.....	6
Table 4. West Point GHG Emissions for Alternative 1.....	7
Table 5. West Point Nitrogen Removal Modeling Results and System Sizing for Alternative 2A.....	8
Table 6. West Point GHG Emissions for Alternative 2A.....	9
Table 7. West Point Nitrogen Removal Modeling Results and System Sizing for Alternative 2B.....	11
Table 8. West Point GHG Emissions for Alternative 2B.....	11
Table 9. West Point Nitrogen Removal Modeling Results and System Sizing for Alternative 2C.....	12
Table 10. West Point GHG Emissions for Alternative 2C.....	13
Table 11. West Point Nitrogen Removal Modeling Results and System Sizing for Alternative 3A.....	14
Table 12. West Point GHG Emissions for Alternative 3A.....	15
Table 13. West Point Nitrogen Removal Modeling Results and System Sizing for Alternative 3D.....	16
Table 14. West Point GHG Emissions for Alternative 3D.....	17
Table 15. West Point Nitrogen Removal Modeling Results and System Sizing for Alternative 4A.....	18
Table 16. West Point GHG Emissions for Alternative 4A.....	19
Table 17. West Point Nitrogen Removal Modeling Results and System Sizing for Alternative 4C.....	21
Table 18. West Point GHG Emissions for Alternative 4C.....	21
Table 19. West Point Nitrogen Removal Modeling Results and System Sizing for Alternative 4D.....	22
Table 20. West Point GHG Emissions for Alternative 4D.....	23
Table 21. West Point Nitrogen Removal Modeling Results and System Sizing for Alternative 4E.....	24
Table 22. West Point GHG Emissions for Alternative 4E.....	24
Table 23. Summary of Capital Costs for West Point Alternatives (Scenarios 1 through 3).....	27
Table 24. Summary of Annual O&M Costs for West Point Alternatives (Scenarios 1 through 3).....	28
Table 25. Summary of Life-Cycle Costs for West Point Alternatives (Scenarios 1 through 3).....	29
Table 26. Comparison of Alternatives – Modeling and LCCA Results (Scenarios 1 through 3).....	34
Table E-1. Summary of Capital Costs for West Point Alternatives (Scenario 4).....	E-2
Table E-2. Summary of Annual O&M Costs for West Point Alternatives (Scenario 4).....	E-2
Table E-3. Summary of Life-Cycle Costs for West Point Alternatives (Scenario 4).....	E-3
Table E-4. Comparison of Alternatives—Modeling and LCCA Results (Scenario 4).....	E-3



## List of Abbreviations

---

°C	degrees Celsius	MLE	modified Ludzack–Ettinger
4SMB	4-Stage Modified Bardenpho	MT	metric tons
AOB	ammonia-oxidizing bacteria	MT/yr	metric tons per year
BAR	bioaugmentation reaeration	mgd	million gallons per day
BOD	biochemical oxygen demand	mg/L	milligrams per liter
CAS	conventional activated sludge	ML	mixed liquor
CEC	compounds of emerging concern	N	nitrogen
CO <sub>2</sub>	carbon dioxide	NOB	nitrite-oxidizing bacteria
CO <sub>2</sub> e	carbon dioxide equivalent	NPV	net present value
County	King County	O&M	operations and maintenance
DT	dry tons	PE	primary effluent
FTE	full-time equivalent	RAS	return activated sludge
gfd	gallons per square foot per day	scfm	standard cubic feet per minute
GHG	greenhouse gas	SRT	solids retention time
HPO	high-purity oxygen	TIN	total inorganic nitrogen
IMLR	internal mixed liquor recycle	TKN	total Kjeldahl nitrogen
IPS	influent pump station	TM	technical memorandum
lb/d	pounds per day	TSS	total suspended solids
LCCA	life-cycle cost analysis	WAS	waste activated sludge
MBR	membrane bioreactor	WTD	Wastewater Treatment Division

## Section 1: Introduction

This technical memorandum (TM) documents the evaluation of selected alternatives for nitrogen removal at the West Point Treatment Plant (West Point). This evaluation follows the initial technology screening analysis (documented in the *Nitrogen Removal Technologies Technical Summaries and Pre-Screening TM* [TM 1]), and the subsequent development of four nitrogen removal scenarios and selection of alternatives for further evaluation (documented in the *West Point Nitrogen Removal Technology Combinations Review and Screening TM* [TM 2]). Each selected alternative was modeled using the previously calibrated biological process simulator BioWin to provide sizing information for expanding existing treatment processes and/or adding new processes. Planning-level information was developed, including:

- Site layouts
- Capital costs
- Operating costs
- Life-cycle cost analyses (LCCAs)
- Anticipated treatment performance and effluent quality related to nitrogen removal
- Estimated biosolids production
- Sustainability analysis results expressed as greenhouse gas (GHG) emissions

Eight alternatives were compared using a matrix of evaluation criteria that was adapted and updated from the previous alternatives screening process. The results were presented in the West Point Nitrogen Removal Workshop 2 with King County's (County) Wastewater Treatment Division (WTD) staff on December 5, 2019. This TM includes changes made to the analysis based on feedback and discussion from the workshop. The final results include a range of costs, GHG emissions, and other operational impacts for alternatives associated with each nitrogen removal scenario.

In general, the results of this evaluation are high-level in nature. A more detailed analysis would be needed to confirm or refine the process sizing and to re-evaluate alternatives selection during facility planning and subsequent design efforts.

## Section 2: Basis of Analysis and Assumptions

To develop the planning-level information for the analysis, the current rated design flows and loadings for West Point were assumed (Table 1). The current rated design flows and loadings were selected as the basis for this evaluation based on discussion with the County. The different nitrogen removal scenarios considered for this analysis include both year-round and seasonal limits. As a result, peaking factors were assumed to calculate the corresponding flows and loadings under different seasonal conditions.



Table 1. West Point Design Flows and Loadings for Nitrogen Removal Analysis		
Parameter	Value	Basis/Reference
<b>Design influent flows and loads</b>		
Annual average		Design drawings for West Point Treatment Plant Secondary Treatment Facilities (1991)
Flow, million gallons per day (mgd)	142	
BOD, pounds per day (lb/d)	168,000	
TSS, lb/d	181,000	
TKN, lb/d	30,000	
Maximum month		Estimated from BOD/TKN ratio from 2017 wastewater characterization Max month flows and loadings also correspond to current rated capacities as shown in NPDES permit effective February 1, 2015
Flow, mgd	215	
BOD, lb/d	201,000	
TSS, lb/d	218,000	
TKN, lb/d	44,700	
<b>Peaking Factors</b>		
Flow		Calculated from projections provided by King County in TM "West Point Treatment Plant Peak Flow and Wasteload Projections 2010-2060" (December 2018)
Max month/average dry weather	2.37	
Max month/average wet weather	1.57	
Biochemical oxygen demand (BOD)		
Max month/average dry weather	1.32	
Max month/average wet weather	1.32	
Total suspended solids (TSS)		
Max month/average dry weather	1.41	
Max month/average wet weather	1.41	
<b>Winter/shoulder average flow and load</b>		
Flow, mgd	137	Average wet weather flow and loads. Use for average winter and shoulder period performance and operating costs
BOD, lb/d	152,000	
TSS, lb/d	155,000	
TKN, lb/d	31,100	
<b>Summer average flow and load</b>		
Flow, mgd	91	Average dry weather flow and loads. Use for average summer period performance and operating costs
BOD, lb/d	152,000	
TSS, lb/d	155,000	
TKN, lb/d	28,900	
<b>Shoulder average flow and max month load</b>		
Flow, mgd	136	Average wet weather flow, max month load Use for sizing worst-case nitrification at minimum shoulder temperature for seasonal scenarios
BOD, lb/d	201,000	
TSS, lb/d	218,000	
TKN, lb/d	44,700	
<b>Winter max month flow and load</b>		
Flow, mgd	215	Max month flow, max month load Use for sizing worst-case nitrification at minimum winter temperature for year-round scenarios
BOD, lb/d	201,000	
TSS, lb/d	218,000	
TKN, lb/d	44,700	

Other assumptions used in modeling the different alternatives include:

- All modeling and sizing conducted for this study was based on the current rated flows and loads for West Point. This was decided to effectively represent the costs of performing nitrogen removal for existing conditions. Further evaluation would be needed to assess impacts of operation at actual and projected flows and loads, as would typically be done for King County basis of design on capital projects.



- For scenarios with a seasonal nitrogen limit, the limit was assumed to apply between April and October. A “shoulder” period is defined as the controlling condition for seasonal nitrogen removal. April is considered the critical month for facility sizing due to the low wastewater temperature typically observed in that month and the potential for peak flows to occur, both of which impact the nitrification process.
- Mixed liquor temperatures, based on effluent temperature data from January 2012 to August 2017, were assumed as follows:
  - Shoulder period: 15.9 degrees Celsius (°C) (average), 12.4°C (minimum)
  - Summer period: 20.2°C (average), 23.0°C (maximum)
  - Winter period: 15.4°C (average), 11.0°C (minimum)
- Secondary influent wastewater characteristics (except for biochemical oxygen demand [BOD] and total suspended solids [TSS]) were based on model calibration for the September 2017 sampling data, adjusted for removal of centrate loads. Calculated ratios of 2.07 for chemical oxygen demand to BOD, and 7.43 for chemical oxygen demand to total Kjeldahl Nitrogen (TKN), were used.
- Centrate characteristics are based on September 2017 centrate sampling data.
- Unless other specified, maximum secondary treatment capacity was assumed to remain at 300 million gallons per day (mgd).
- At least one aeration basin can be out of service during the summer period (not including the shoulder periods if seasonal nitrification is required).
- Except for the Scenario 2 alternatives, which involve conversion to membrane bioreactor (MBR) process, all secondary clarifiers are assumed to be in service during the shoulder and winter periods, and at least two clarifiers can be out of service during the summer period.
- For alternatives including a MBR process, membrane basin sizing and membrane requirements were determined by assuming a peak flux rate of 10 gallons per square foot per day (gfd) under either winter or shoulder conditions. This peak flux rate is similar to the peak hour membrane capacity of 28 mgd under winter conditions for the existing MBR system at the Brightwater Treatment Plant (Brightwater) based on peak flow test data from August 2013 to June 2015. A peak flux rate of 10 gfd is considerably lower than the typical design flux rate used by the membrane manufacturer. For example, Suez, which supplies the MBR equipment at Brightwater, recommends a peak design flux rate of 18.2 gfd at a design minimum temperature of 11°C. Budgetary proposals were obtained for both the 10-gfd flux limit and the manufacturer’s recommended peak design flux limit, but site layouts and cost estimating are based on the 10-gfd flux limit. Budgetary proposals for equipment are included in Attachment E.
- Site layouts developed from the modeling results for each alternative are preliminary and do not account for planned future capital projects unless otherwise specified on the site layouts. Any capital project for nitrogen removal will require further facility planning and alternatives analysis to evaluate other treatment plant needs and upgrades

In addition to biological process modeling, a high-level GHG inventory was completed for each of evaluated alternative. This GHG inventory was estimated based on the following methods and assumptions:

- The accounting of GHG emissions considered only operation emissions as a result of indirect and direct emissions. No GHG emissions were accounted for during construction (concrete, materials, machinery, fuel consumption, etc.). However, it can be assumed that alternatives that require extensive amounts of concrete for construction are likely to have significantly higher purchasing-related emissions than alternatives that do not require extensive amounts of concrete.
- Accounting of emissions included direct nitrous oxide emissions from treatment, as well as carbon dioxide (CO<sub>2</sub>) emissions from transportation and materials usage and energy consumption.

- CO<sub>2</sub> emissions for energy use were based on the energy-source profile provided by the County for West Point, with an emission factor of 0.0089 metric tons (MT) of CO<sub>2</sub> equivalent (CO<sub>2</sub>e) per megawatt-hour. It is worth noting that the GHG emissions for production of the electricity supplied to West Point are relatively low compared to most locations in the United States.
- Biogenic carbon dioxide emissions were not considered as part of the inventory as per the International Panel for Climate Change carbon accounting protocol and framework.
- “Chapter 6 Nitrous Oxide Emissions from Domestic Wastewater” was used as the primary method for estimating emissions. This method can be found in the 2019 Refinement to the 2006 Guidelines for National Greenhouse Gas Inventories.
- Nitrous oxide emission factors were developed from a comprehensive literature review of different studies (Attachment B).
- King County’s Strategic Climate Action Plan requires WTD to be carbon neutral for its operations- and purchasing-related greenhouse gas emissions by 2025. The updated 2020 Strategic Climate Action Plan will likely require capital projects to purchase offsets for their purchasing-related emissions. WTD’s current cost for purchasing offsets is \$10 per metric ton of carbon. The results of the GHG analysis are used for comparative purposes in this study, but it was not used to account for carbon offset costs in the LCCA due to the high-level nature of this analysis. A detailed GHG study should be completed as part of any future facility planning effort for West Point.

### Section 3: Discussion of Alternatives

As a result of West Point Nitrogen Removal Workshop 1 with County staff on May 14, 2019, four nitrogen removal scenarios and 12 alternatives were initially selected for the site-specific analysis for West Point, as described in TM 2. Subsequently, one new alternative (3D) was added to scenario 3, and one alternative (4B) was eliminated from further analysis. Evaluation of alternatives 3B and 3C, both involving partial granulation, were postponed pending results of the partial granulation pilot study being conducted at West Point. Therefore, this TM does not include discussion of those alternatives. The scenarios and alternatives evaluated in this analysis of planning alternatives are summarized in Table 2.

Table 2. Summary of Selected Alternatives for West Point Nitrogen Removal Scenarios	
Alternative	Description
Scenario 1: Sidestream treatment only	
1	Existing mainstream + sidestream anammox
Scenario 2: Year-round N removal, lowest effluent TIN possible while maintaining existing secondary treatment capacity	
2A	MLE/MBR
2B	MLE/MBR + sidestream anammox
2C	4SMB/MBR + sidestream anammox
Scenario 3: Seasonal N removal, lowest effluent TIN possible while maintaining existing secondary treatment capacity	
3A	MLE/MBR + sidestream anammox
3D	4SMB/MBR + sidestream anammox



Table 2. Summary of Selected Alternatives for West Point Nitrogen Removal Scenarios	
Alternative	Description
Scenario 4: Year-round N removal, effluent TIN limit of 8 mg/L (identify reduced secondary treatment capacity)	
4A	MLE
4C	MLE + sidestream bioaugmentation
4D	4SMB + sidestream anammox
4E	4SMB + sidestream bioaugmentation

*N* = nitrogen

*TIN* = total inorganic nitrogen

*MLE* = Modified Ludzack-Ettinger

*MBR* = membrane bioreactor

*4SMB* = 4-Stage Modified Bardenpho

The following sections discuss each of the alternatives, including process description, modeling results, facility sizing, major equipment requirements, site layouts, and GHG emissions. Site layouts for each alternative consist of an aerial photograph of the plant marked up to show new or modified facilities and approximate flow paths for major piping. All site layouts are provided in Attachment A.

A plant hydraulic profile analysis was not conducted as part of this evaluation. It is recommended that a hydraulic analysis be conducted to confirm the hydraulic capability or to add hydraulic improvements as needed during facility planning and detailed design.

It should be noted that Table 2 does not include the granular sludge alternative that was discussed in the initial screening workshops held with WTD. While there is currently insufficient available data on the kinetic rates of nitrifying and denitrifying granular sludge augmentation reactors, WTD and University of Washington have designed and have been operating a pilot system at West Point to address data gaps so that the system could be analyzed. Data was initially to be available this spring to complete the analysis. However, because of setbacks in mainstream granule separation in the pilot, and the recent decision by WTD to shut down all pilot systems in compliance with the State of Washington’s “Stay Home, Stay Healthy” order in response to the COVID-19 pandemic in March 2020, results will not be available to be included as part of this study. The granulation technology being investigated does show promise for full-scale implementation and should be reevaluated as an alternative in future facility planning studies once sufficient data is available to allow for system sizing.

### 3.1 Scenario 1 – Sidestream Treatment Only

This scenario minimizes capital improvements but also provides the least nitrogen removal relative to other options. Only one alternative is included for this scenario, as described below. The sidestream process was sized based on winter maximum month flow and loading conditions.

#### 3.1.1 Alternative 1 – Existing Mainstream + Sidestream Anammox

In this alternative, the existing high-purity oxygen (HPO) activated sludge process would remain as the secondary treatment process. An anammox-based sidestream process would be added to reduce ammonia loading from the centrate that is routed to the secondary system by converting it to nitrogen gas. Figure 1 shows a process flow schematic for this alternative. An anammox-based process is assumed for this alternative as the only other feasible sidestream process, bioaugmentation, would need to be configured for nitrification/denitrification instead of nitrification alone and would have higher operating costs and added complexity compared to an anammox system.



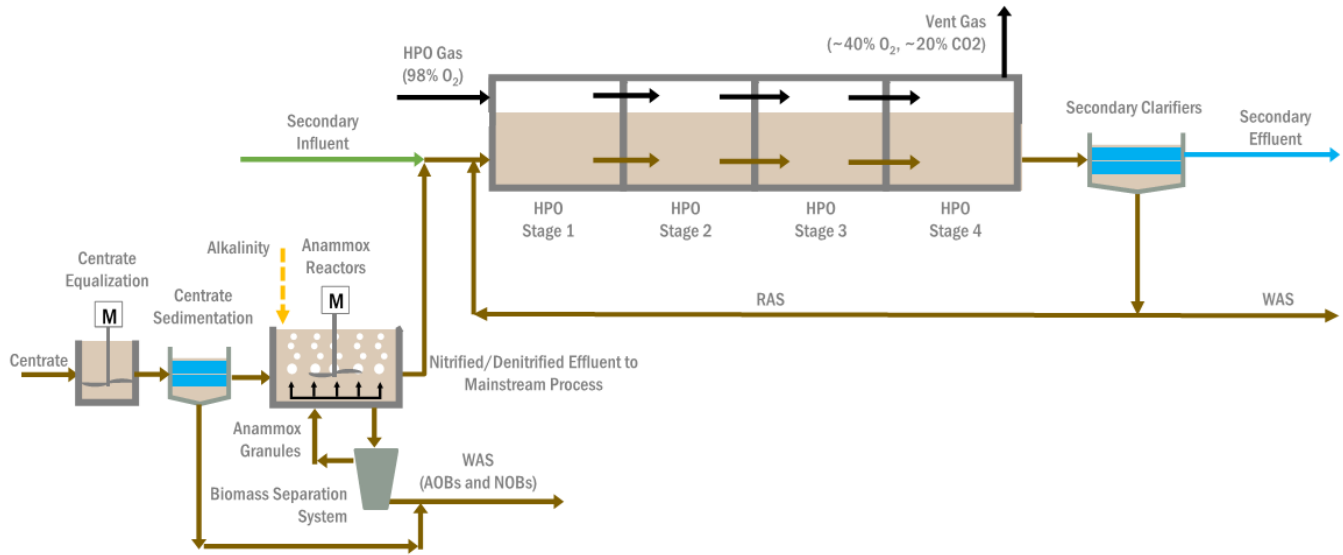

**Figure 1. Process flow schematic for Alternative 1 – existing mainstream + sidestream anammox**  
(AOB = ammonia-oxidizing bacteria, NOB = nitrite-oxidizing bacteria, WAS = waste activated sludge)

Table 3 summarizes the modeling results and sizing of major facilities and equipment for Alternative 1.

Table 3. West Point Nitrogen Removal Modeling Results and System Sizing for Alternative 1	
Parameter	Value
Secondary effluent TIN, mg/L	
@ Winter max month flow and load	19
@ summer avg dry weather flow and load	27
@ winter avg wet weather flow and load	19
Overall TN removal, % <sup>a</sup>	
@ Winter max month flow and load	13
@ summer avg dry weather flow and load	22
@ winter avg wet weather flow and load	18
Annual average	20
Annual average aeration requirements	
HPO gas, tons/day	89
Aeration basin air flow, scfm	-
Membrane scouring air flow, scfm	-
Annual average supplemental chemical requirements	
Alkalinity (25% caustic), gpd	0
Methanol, gpd	0
No. of new aeration basins	0
Sidestream treatment	
Type	Anammox
Centrate equalization tank volume, gal	80,000
No. of reactor tanks	2
Volume of reactor tanks, gal	375,000

a. Overall removal accounts for bypass around secondary treatment when flow exceeds 300 mgd.  
scfm = standard cubic feet per minute

A preliminary site layout for Alternative 1 is provided in Attachment A. While the new sidestream treatment facility, assumed to be located between secondary clarifier 1 and the flow diversion structure, would interfere with construction of new clarifiers in the future, the facility for this alternative can be constructed with relatively short implementation time and minimal impacts to the existing plant operations. This alternative, however, provides limited overall nitrogen removal, with average secondary effluent total inorganic nitrogen (TIN) concentrations well above 10 milligrams per liter (mg/L) and an annual average TN removal of approximately 19 percent (as indicated by the results in Table 3).

Table 4 summarizes the estimated GHG emissions for Alternative 1.

Table 4. West Point GHG Emissions for Alternative 1	
Parameter	Value
GHG emissions carbon dioxide equivalent, metric tons per year (CO <sub>2</sub> e MT/yr)	
Nitrous oxide	10,400
Energy	210
Chemicals	0
Total	10,600

MT = metric ton(s)

### 3.2 Scenario 2 – Year-round Nitrogen Removal with Lowest Effluent TIN Possible while Maintaining Existing Secondary Treatment Capacity

For this scenario, West Point would achieve nitrogen removal year-round. The analysis was performed to achieve the lowest possible effluent TIN concentration while maintaining the current secondary treatment capacity and utilizing only the existing treatment plant site with planned expansion areas. Three alternatives were evaluated for this scenario, as described below. System sizing for these alternatives were based on winter maximum month flow and loading conditions.

#### 3.2.1 Alternative 2A – MLE/MBR

In this alternative, the current HPO activated sludge process would be replaced with an MBR process. The existing HPO basins will be converted into air-activated sludge aeration basins configured for the modified Ludzack-Ettinger (MLE) process, and the secondary clarifiers would be replaced with membrane tanks. Figure 2 shows a process flow schematic for this alternative. In an MLE process, the aeration basins consist of an unaerated (anoxic) zone followed by an aerated zone, with an internal mixed liquor recycle (IMLR) pumped from the aerated zone back to the anoxic zone. When configured as an MLE/MBR process, the mixed liquor from the aeration basins is sent to the membrane basins instead of clarifiers for solids separation. MBR treatment requires fine screening to protect the membranes from debris; therefore, new primary effluent fine screens will be added as part of this alternative.

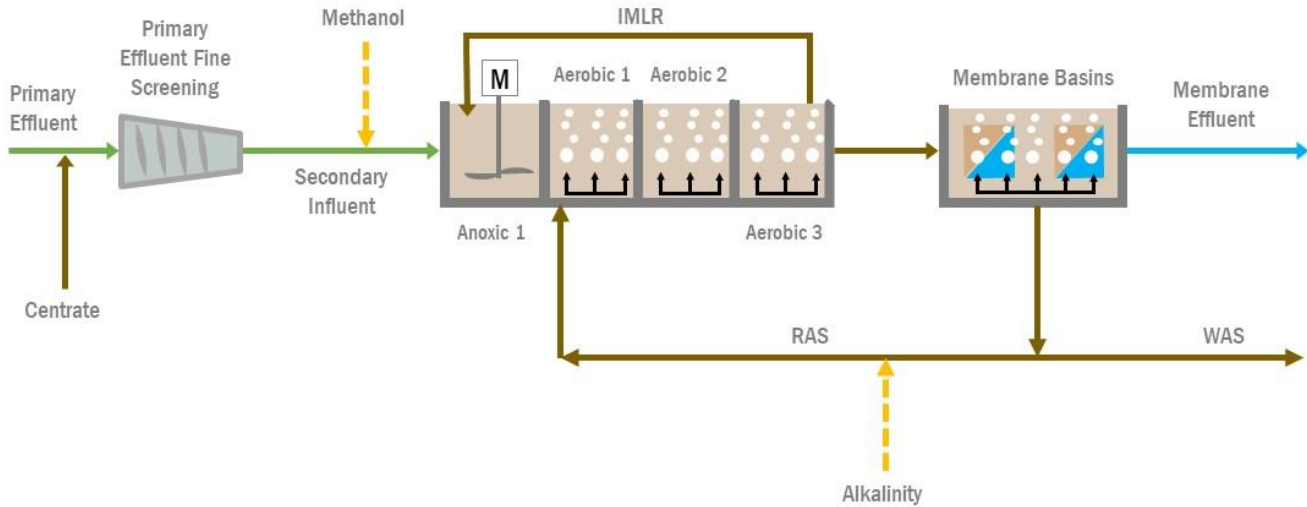

Figure 2. Process flow schematic for Alternative 2A – MLE/MBR

Table 5 summarizes the modeling results and sizing of major facilities and equipment for Alternative 2A.

Table 5. West Point Nitrogen Removal Modeling Results and System Sizing for Alternative 2A	
Parameter	Value
Secondary effluent TIN, mg/L	
@ Winter max month flow and load	8.0
@ summer avg dry weather flow and load	7.0
@ winter avg wet weather flow and load	7.0
Overall TN removal, % <sup>a</sup>	
@ Winter max month flow and load	60
@ summer avg dry weather flow and load	78
@ winter avg wet weather flow and load	70
Annual average	74
Annual average aeration requirements	
HPO gas, tons/day	-
Aeration basin air flow, scfm	43,700
Membrane scouring air flow, scfm	154,100
Annual average supplemental chemical requirements	
Alkalinity (25% caustic), gpd	15,000
Methanol, gpd	7,130
New aeration basins	
Number of new basins	2
Volume per basin, MG	2.35
New membrane basins	
Peak hydraulic capacity (at 10 gfd flux limit)	300
Number of new basins	58
Volume per basin, MG	0.20

a. Overall removal accounts for bypass around secondary treatment when flow exceeds 300 mgd.

MG = million gallons



A preliminary site layout for Alternative 2A is provided in Attachment A. The existing secondary clarifiers, except for clarifier 13, will need to be demolished to provide space for the membrane basins. Two new aeration basins will be added on the east side of the site adjacent the existing HPO basins (in the planned expansion area), which would be converted to air-activated sludge basins. The new supplemental alkalinity and methanol storage and feed systems are assumed to be located next to secondary clarifiers 1 and 2. That space currently serves as a staging area for the biosolids trucks; therefore, a new staging area would need to be identified. The higher biosolids production (shown in Table 26 in Section 5.2) and chemical requirements for this alternative would mean more truck traffic that would need to be accommodated on-site.

**Challenges and Potential Risks.** There will be significant conveyance challenges associated with routing primary effluent (PE), mixed liquor (ML) and return activated sludge (RAS). PE will be pumped from the intermediate pump station (IPS) to the new PE fine screens (assumed to be elevated). From there, PE will then flow by gravity to the aeration basins. In an MBR system, high recycle rates are used to prevent excessive sludge accumulation at the membranes and to maintain proper solids inventory distribution between the aeration and membrane basins. At West Point, the ML and secondary effluent are conveyed in stacked channels on top of the chlorine contact channel between clarifiers on the north and south banks of secondary clarifiers. For this alternative, the ML channel will convey up to five times the secondary influent flow (5Q) (4Q of RAS flow and 1Q of secondary influent flow). The 4Q of RAS flow was assumed to apply up to the design maximum month flow. For this analysis, it was assumed that the existing channel can accommodate the high flows. A more detailed hydraulic analysis is recommended to confirm the hydraulic capacity. Large above-ground conduits were assumed to convey the RAS from the membrane basins to the aeration basins, with new RAS pumping stations to pump RAS collected at the membrane basins to the aeration basins. Similarly, above-ground aeration air piping was assumed to supply air to the fine-pore diffusers in the aeration basins from the blowers, assumed to be located in the existing oxygen generation facility. The large above-ground piping would further constrain site footprint. To reduce aeration air piping length, a new blower building could be constructed at the location of clarifier 13.

Constructing this option will be very difficult while maintaining secondary treatment capacity because the secondary clarifiers will need to be demolished to construct the membrane basins. Offsite grading and shoring would be needed to construct the two new aeration basins, and an influent conveyance pipe would need to be re-aligned. Exact methods for construction should be evaluated in detail during detailed planning efforts for this option.

Potential risks for this alternative include insufficient existing power supply for the increased electrical loads, lower than expected membrane permeability which would limit secondary treatment capacity, high operational complexity, and no available space for future aeration basin expansion. These risks were accounted for in the cost estimates and overall analysis of planning alternatives discussed in Section 5.

Table 6 summarizes the estimated GHG emissions for Alternative 2A.

Table 6. West Point GHG Emissions for Alternative 2A	
Parameter	Value
GHG emissions (CO <sub>2</sub> e MT/yr)	
Nitrous oxide	4,100
Energy	920
Chemicals	21,100
Total	26,100





### 3.2.2 Alternative 2B – MLE/MBR + Sidestream Anammox

This alternative is similar to Alternative 2A, with addition of sidestream anammox. Figure 3 shows a process flow schematic for Alternative 2B.

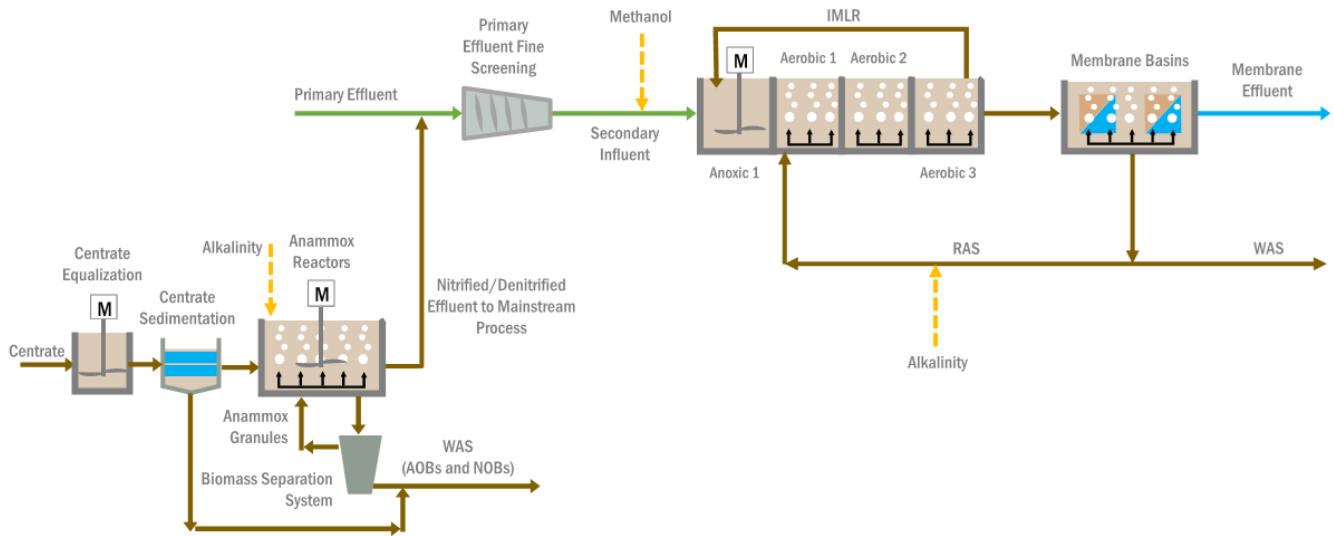

Figure 3. Process flow schematic for Alternative 2B – MLE/MBR + sidestream anammox.

Table 7 summarizes the modeling results and sizing of major facilities and equipment for Alternative 2B.

Table 7. West Point Nitrogen Removal Modeling Results and System Sizing for Alternative 2B	
Parameter	Value
Secondary effluent TIN, mg/L	
@ Winter max month flow and load	7.9
@ summer avg dry weather flow and load	6.9
@ winter avg wet weather flow and load	6.6
Overall TN removal, % <sup>a</sup>	
@ Winter max month flow and load	60
@ summer avg dry weather flow and load	78
@ winter avg wet weather flow and load	71
Annual average	75
Annual average aeration requirements	
HPO gas, tons/day	-
Aeration basin air flow, scfm	39,000
Membrane scouring air flow, scfm	154,100
Annual average supplemental chemical requirements	
Alkalinity (25% caustic), gpd	15,000
Methanol, gpd	5,300
New aeration basins	
Number of new basins	2
Volume per basin, MG	2.35
New membrane basins	
Peak hydraulic capacity (at 10 gfd flux limit)	300
Number of new basins	58
Volume per basin, MGI	0.20
Sidestream treatment	
Type	Anammox
Centrate equalization tank volume, gal	80,000
No. of reactor tanks	2
Volume of reactor tanks, gal	375,000

a. Overall removal accounts for bypass around secondary treatment when flow exceeds 300 mgd.

A preliminary site layout for Alternative 2B is provided in Attachment A. The layout for this alternative is the same as that for Alternative 2A, except for the addition of a new sidestream anammox facility. New aeration basin and membrane basin sizing also remains the same. This alternative has similar **challenges and potential risks** as Alternative 2A. Table 8 summarizes the estimated GHG emissions for Alternative 2B.

Table 8. West Point GHG Emissions for Alternative 2B	
Parameter	Value
GHG emissions (CO <sub>2</sub> e MT/yr)	
Nitrous oxide	5,800
Energy	920
Chemicals	19,700
Total	26,400

### 3.2.3 Alternative 2C – 4SMB/MBR + Sidestream Anammox

This alternative is similar to Alternative 2B, but with a 4-Stage Modified Bardenpho (4SMB) instead of MLE process. Figure 4 shows a process flow schematic for this alternative. The 4SMB process is an expansion of the MLE process, with addition of a second set of anoxic and aerobic zones. The ML leaving the first aerobic zone enters a second anoxic zone where the residual nitrate is further reduced. The second aerated zone serves as a polishing step to nitrify the ammonia formed in the second anoxic zone and to oxidize any

residual carbon from the second anoxic zone. External carbon, such as methanol, is often required at the second anoxic zone to drive denitrification because readily biodegradable carbon has already been consumed upstream.

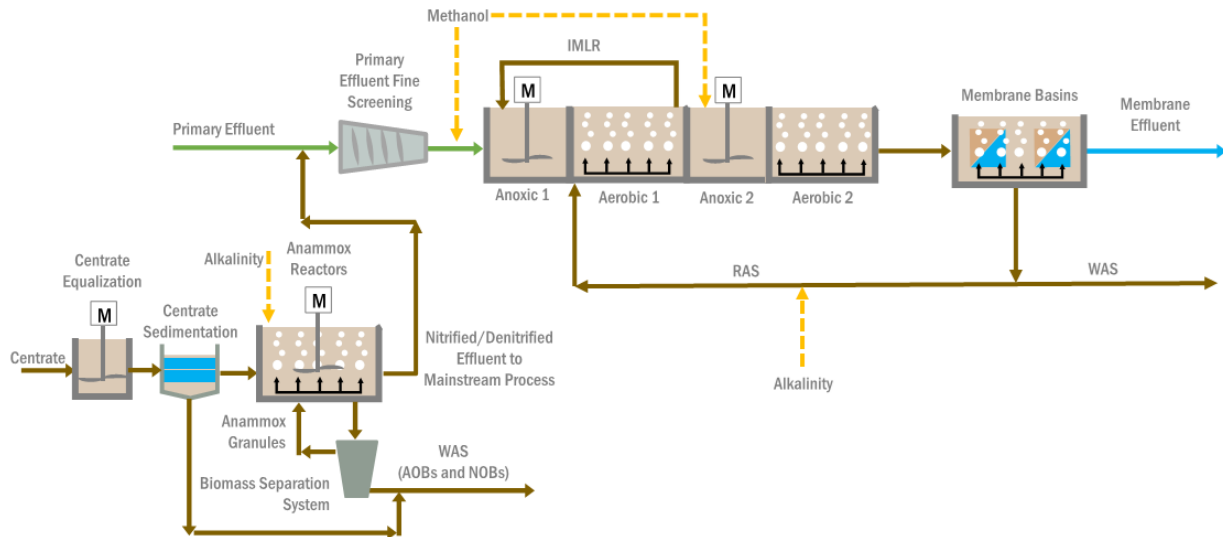

Figure 4. Process flow schematic for Alternative 2C – 4SMB/MBR + sidestream anammox

Table 9 summarizes the modeling results and sizing of major facilities and equipment for Alternative 2C.

Table 9. West Point Nitrogen Removal Modeling Results and System Sizing for Alternative 2C	
Parameter	Value
Secondary effluent TIN, mg/L	
@ Winter max month flow and load	3.1
@ summer avg dry weather flow and load	2.8
@ winter avg wet weather flow and load	2.8
Overall TN removal, % <sup>a</sup>	
@ Winter max month flow and load	78
@ summer avg dry weather flow and load	89
@ winter avg wet weather flow and load	85
Annual average	87
Annual average aeration requirements	
HPO gas, tons/day	-
Aeration basin air flow, scfm	32,550
Membrane scouring air flow, scfm	154,100
Annual average supplemental chemical requirements	
Alkalinity (25% caustic), gpd	10,500
Methanol, gpd	5,800
New aeration basins	
Number of new basins	2
Volume per basin, MG	2.35
New membrane basins	
Peak hydraulic capacity (at 10 gfd flux limit)	300
Number of new basins	58
Volume per basin, MG	0.20

**Table 9. West Point Nitrogen Removal Modeling Results and System Sizing for Alternative 2C**

Parameter	Value
Sidestream treatment	
Type	Anammox
Centrate equalization tank volume, gal	80,000
No. of reactor tanks	2
Volume of reactor tanks, gal	375,000

a. Overall removal accounts for bypass around secondary treatment when flow exceeds 300 mgd.

A preliminary site layout for Alternative 2C is provided in Attachment A. The layout for this alternative is the same as that for Alternative 2B. The configuration of the aeration basins (including both the basins converted from HPO basins and the new aeration basins) differs from that for Alternative 2B, with the two anoxic and two aerobic zones and mixers in the second anoxic zones. New aeration basin and membrane basin sizing remains the same. This alternative has similar **challenges and potential risks** as Alternatives 2A and 2B. Table 10 summarizes the estimated GHG emissions for Alternative 2C.

**Table 10. West Point GHG Emissions for Alternative 2C**

Parameter	Value
GHG emissions (CO <sub>2</sub> e MT/yr)	
Nitrous oxide	14,800
Energy	890
Chemicals	15,700
Total	31,400

### 3.3 Scenario 3 – Seasonal Nitrogen Removal with Lowest Effluent TIN Possible while Maintaining Existing Secondary Treatment Capacity

For this scenario, West Point would provide seasonal nitrogen removal, assumed to be between April and October. The analysis was performed to achieve the lowest possible effluent TIN concentration while maintaining the current secondary treatment capacity. Two alternatives were evaluated for this scenario, as described below. System sizing for these alternatives were based on shoulder period average wet weather flow and maximum month loading conditions.

#### 3.3.1 Alternative 3A – MLE/MBR + Sidestream Anammox

In this alternative, the secondary system will consist of two parallel processes: conventional activated sludge (CAS) and MBR. The existing HPO basins will be converted into air-activated sludge aeration basins configured for the MLE process. Two new aeration basins will be added, also configured for the MLE process. New membrane basins will replace some of the secondary clarifiers as part of the MBR process. The remaining clarifiers will become part of the CAS process. Full MBR treatment is not required for this alternative as nitrogen removal is not required in the winter, thus allowing the CAS process to operate at lower solids retention time (SRT) in the winter to reduce solids loading to the secondary clarifiers. Figure 5 shows a process flow schematic for this alternative.

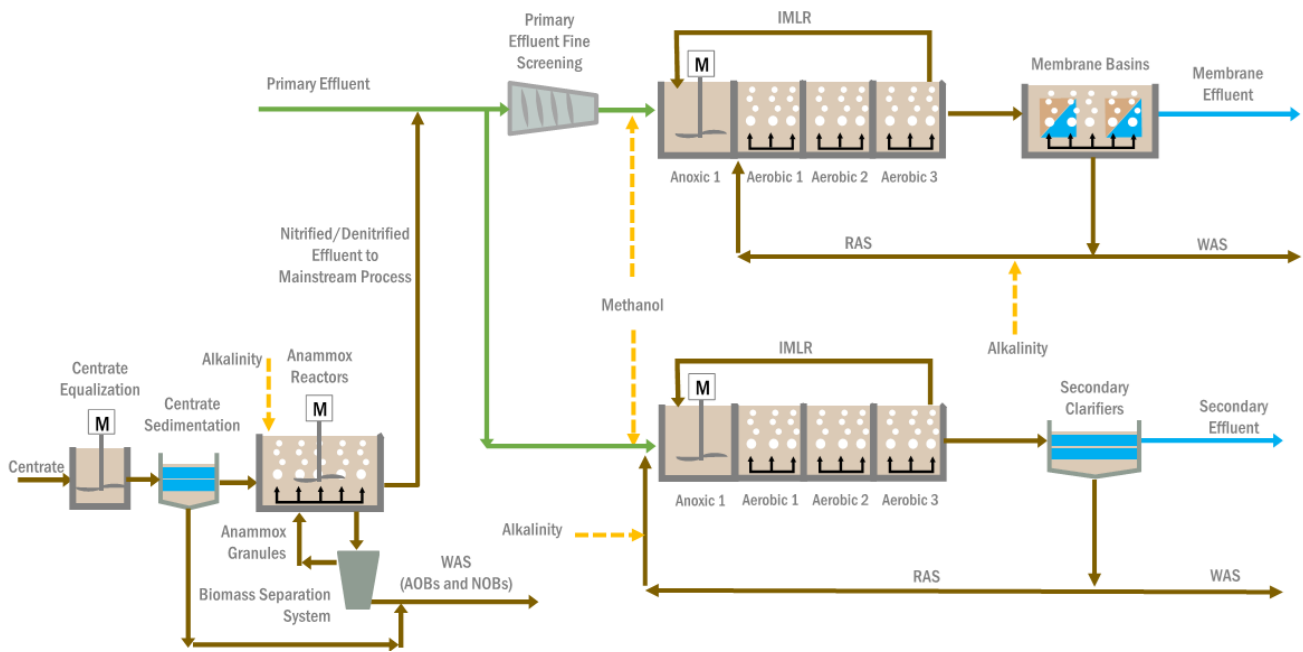

Figure 5. Process flow schematic for Alternative 3A – MLE/MBR + sidestream anammox

Table 11 summarizes the modeling results and sizing of major facilities and equipment for Alternative 3A.

Table 11. West Point Nitrogen Removal Modeling Results and System Sizing for Alternative 3A	
Parameter	Value
Secondary effluent TIN, mg/L	
@ Winter max month flow and load	17
@ shoulder avg wet weather flow and max month load	19
@ summer avg dry weather flow and load	7.0
@ winter avg wet weather flow and load	17
Overall TN removal, % <sup>a</sup>	
@ Winter max month flow and load	25
@ summer avg dry weather flow and load	77
@ winter avg wet weather flow and load	33
Annual average	54
Annual average aeration requirements	
HPO gas, tons/day	-
Aeration basin air flow, scfm	35,700
Membrane scouring air flow, scfm	35,200
Annual average supplemental chemical requirements	
Alkalinity (25% caustic), gpd	12,000
Methanol, gpd	2,300
New aeration basins	
Number of new basins	2
Volume per basin, MG	2.35
New membrane basins	
Peak hydraulic capacity (at 10 gfd flux limit)	70
Number of new basins	16
Volume per basin, MG	0.15

Table 11. West Point Nitrogen Removal Modeling Results and System Sizing for Alternative 3A	
Parameter	Value
<b>Sidestream treatment</b>	
Type	Anammox
Centrate equalization tank volume, gal	80,000
No. of reactor tanks	2
Volume of reactor tanks, gal	375,000

a. Overall removal accounts for bypass around secondary treatment when flow exceeds 300 mgd

The site layout for Alternative 3A is provided in Attachment A. In this plan layout, secondary clarifiers 11, 12, and 13 are shown to be demolished to make space for the new membrane basins, RAS pump station, and primary effluent screening facility. Two of the existing HPO basins will be converted to MLE basins for the MBR process, while the other four HPO basins will be converted to MLE basins for the CAS process. Two new aeration basins will be added and operated as part of the CAS process.

**Challenges and Potential Risks.** As illustrated on the site layout, there is limited space for constructing the membrane basins and PE screening facility. PE will split after the IPS between the CAS and MBR processes, which could be done by either dedicating pumps to pump PE to the screening facility or pumping all PE flow to a flow split structure just upstream of the screens. The large RAS conduits required for the MBR process and the aeration air headers for both processes will likely need to be installed above grade, which would further constrain site footprint.

In terms of potential risks, this alternative will have lower electrical loads than the Scenario 2 alternatives, but the existing power supply is likely still insufficient. Fluctuation in operating membrane permeability is also a risk, but with the parallel MLE-CAS system, the impact will be less than for the Scenario 2 alternatives. Operational complexity will be particularly high to operate the two parallel secondary systems. There is also no available space for future aeration basin expansion. Table 12 summarizes the estimated GHG emissions for Alternative 3A.

Table 12. West Point GHG Emissions for Alternative 3A	
Parameter	Value
<b>GHG emissions (CO<sub>2</sub>e MT/yr)</b>	
Nitrous oxide	7,700
Energy	420
Chemicals	13,700
Total	21,800

### 3.3.2 Alternative 3D – 4SMB/MBR + Sidestream Anammox

This alternative is similar to Alternative 3A, but with a 4SMB instead of MLE process. See Section 3.2.3 for description of the 4SMB process. Figure 6 shows a process flow schematic for this alternative.

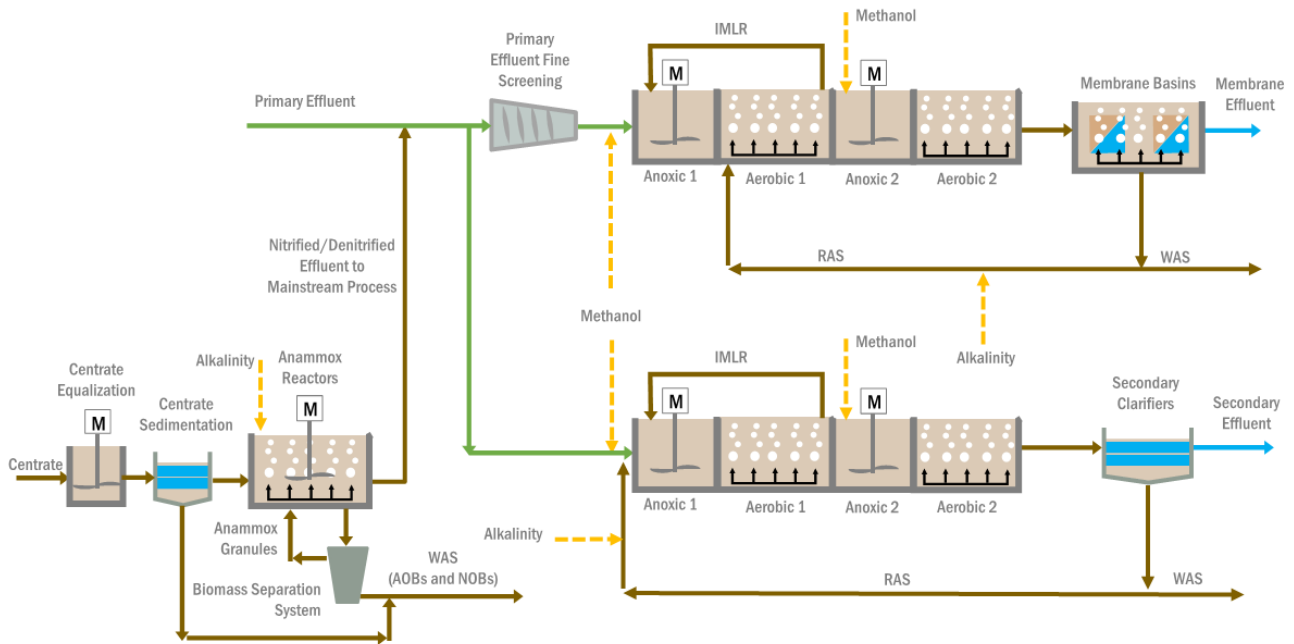

Figure 6. Process flow schematic for Alternative 3D – 4SMB/MBR + sidestream anammox

Table 13 summarizes the modeling results and sizing of major facilities and equipment for Alternative 3D.

Table 13. West Point Nitrogen Removal Modeling Results and System Sizing for Alternative 3D	
Parameter	Value
Secondary effluent TIN, mg/L	
@ Winter max month flow and load	17
@ shoulder avg wet weather flow and max month load	16
@ summer avg dry weather flow and load	2.5
@ winter avg wet weather flow and load	17
Overall TN removal, % <sup>a</sup>	
@ Winter max month flow and load	25
@ summer avg dry weather flow and load	89
@ winter avg wet weather flow and load	33
Annual average	60
Annual average aeration requirements	
HPO gas, tons/day	-
Aeration basin air flow, scfm	33,100
Membrane scouring air flow, scfm	35,200
Annual average supplemental chemical requirements	
Alkalinity (25% caustic), gpd	10,000
Methanol, gpd	2,150
New aeration basins	
Number of new basins	2
Volume per basin, MG	2.35

Parameter	Value
<b>New membrane basins</b>	
Peak hydraulic capacity (at 10 gfd flux limit)	70
Number of new basins	16
Volume per basin, MG	0.15
<b>Sidestream treatment</b>	
Type	Anammox
Centrate equalization tank volume, gal	80,000
No. of reactor tanks	2
Volume of reactor tanks, gal	375,000

a. Overall removal accounts for bypass around secondary treatment when flow exceeds 300 mgd.

A preliminary site layout for Alternative 3D is provided in Attachment A. The layout for this alternative is the same as that for Alternative 3A, aside from the internal configuration of the aeration basins, which would be configured for the 4SMB process. This alternative has similar **challenges and potential risks** as Alternative 3A. Table 14 summarizes the estimated GHG emissions for Alternative 3D.

Parameter	Value
<b>GHG emissions (CO<sub>2</sub>e MT/yr)</b>	
Nitrous oxide	14,100
Energy	410
Chemicals	11,600
Total	26,100

### 3.4 Scenario 4 – Year-round Nitrogen Removal with Effluent TIN of 8 mg/L and Reduced Secondary Treatment Capacity

For this scenario, West Point would provide year-round nitrogen removal to achieve an effluent TIN concentration of 8 mg/L at a reduced secondary treatment capacity. It was assumed that flows would be diverted away from West Point to allow the secondary system to meet the target TIN limit, which would require extensive modifications to the collection system and construction of a new WWTP to accommodate the lost capacity of West Point and also provide nitrogen removal (consideration of collection system modifications or provisions for a new WWTP were beyond the scope of this study). Four alternatives were evaluated for this scenario, as described below. System sizing for these alternatives were based on winter maximum month flow and loading conditions.

#### 3.4.1 Alternative 4A – MLE

In this alternative, the current HPO activated sludge process is converted into an MLE-CAS process. Figure 7 shows a process flow schematic for this alternative.



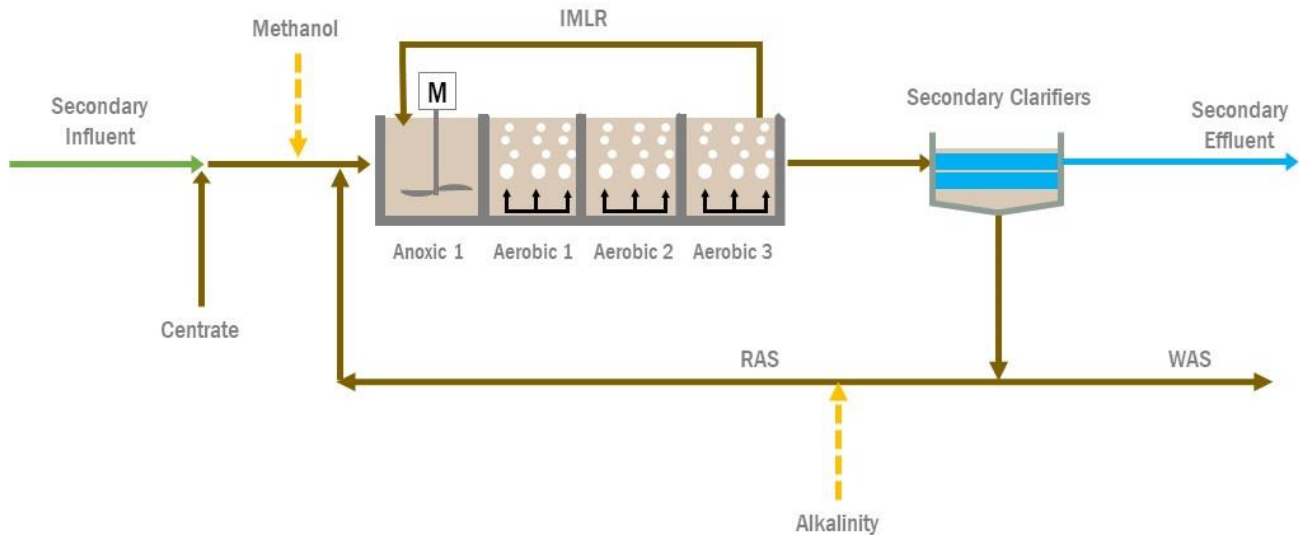

Figure 7. Process flow schematic for Alternative 4A - MLE

Table 15 summarizes the modeling results and sizing of major facilities and equipment for Alternative 4A. Process modeling showed that to meet the target effluent TIN limit of 8 mg/L (assumed to be an equivalent limit on an annual average basis), the maximum month flow capacity would be reduced from the current rated value of 215 mgd to 98 mgd, corresponding to a loss of more than 50 percent of the rated capacity. This is based on a more limited plant upgrade compared to those for the Scenario 2 and 3 alternatives.

Table 15. West Point Nitrogen Removal Modeling Results and System Sizing for Alternative 4A	
Parameter	Value
Maximum month flow capacity, mgd	98
Lost plant capacity (maximum month flow), mgd <sup>a</sup>	117
Secondary effluent TIN, mg/L	
@ Winter max month flow and load	9.0
@ summer avg dry weather flow and load	6.6
@ winter avg wet weather flow and load	8.7
Overall TN removal, % <sup>b</sup>	
@ Winter max month flow and load	57
@ summer avg dry weather flow and load	78
@ winter avg wet weather flow and load	61
Annual average	69
Annual average aeration requirements	
HPO gas, tons/day	-
Aeration basin air flow, scfm	23,500
Membrane scouring air flow, scfm	-
Annual average supplemental chemical requirements	
Alkalinity (25% caustic), gpd	7,500
Methanol, gpd	1,880
New aeration basins	
Number of new basins	2
Volume per basin, MG	2.35

a. Lost capacity based on the current rated maximum month flow capacity of 215 mgd.

b. Overall removal accounts for bypass around secondary treatment when flow exceeds 300 mgd.

A preliminary site layout for Alternative 4A is provided in Attachment A. In this plan layout, the existing secondary clarifiers remain, the existing HPO basins are converted to MLE basins for the CAS process, and two new basins are added. Because the West Point secondary treatment capacity is reduced for this alternative (and other alternatives for Scenario 4), construction of a new greenfield treatment facility and collection system modifications would be required. The site layout illustrates facilities at West Point only, not accounting for new facilities required outside of West Point.

As an alternative to the MLE-CAS process, the existing HPO process could be converted to an MLE-HPO process (as described in TM 2). It was determined that MLE-HPO is a possible alternative for seasonal nitrogen removal at a reduced secondary treatment capacity; however, because of a number of potential process performance risks, it was not carried forward for further analysis. MLE-HPO could be re-considered as part of a future project.

**Challenges and Potential Risks.** Besides the reduced treatment capacity, the main potential risks for this alternative are the lack of available space for future aeration basin expansion and limited available space for secondary clarifier expansion.

Table 16 summarizes the estimated GHG emissions for Alternative 4A.

<b>Table 16. West Point GHG Emissions for Alternative 4A</b>	
<b>Parameter</b>	<b>Value</b>
GHG emissions (CO <sub>2</sub> e MT/yr)	
Nitrous oxide	2,000
Energy	130
Chemicals	8,700
Total	10,900

### 3.4.2 Alternative 4C – MLE + Sidestream Bioaugmentation

This alternative is similar to Alternative 4A, with addition of sidestream bioaugmentation. In bioaugmentation, the ammonia-rich centrate is combined with RAS in a sidestream aeration basin to achieve nitrification. Sending the nitrified effluent from this sidestream basin, which is enriched with nitrifying organisms, enhances the nitrification process in the mainstream aeration basins. For this evaluation, the bioaugmentation reaeration (BAR) configuration was assumed. Figure 8 shows a process flow schematic for this alternative.

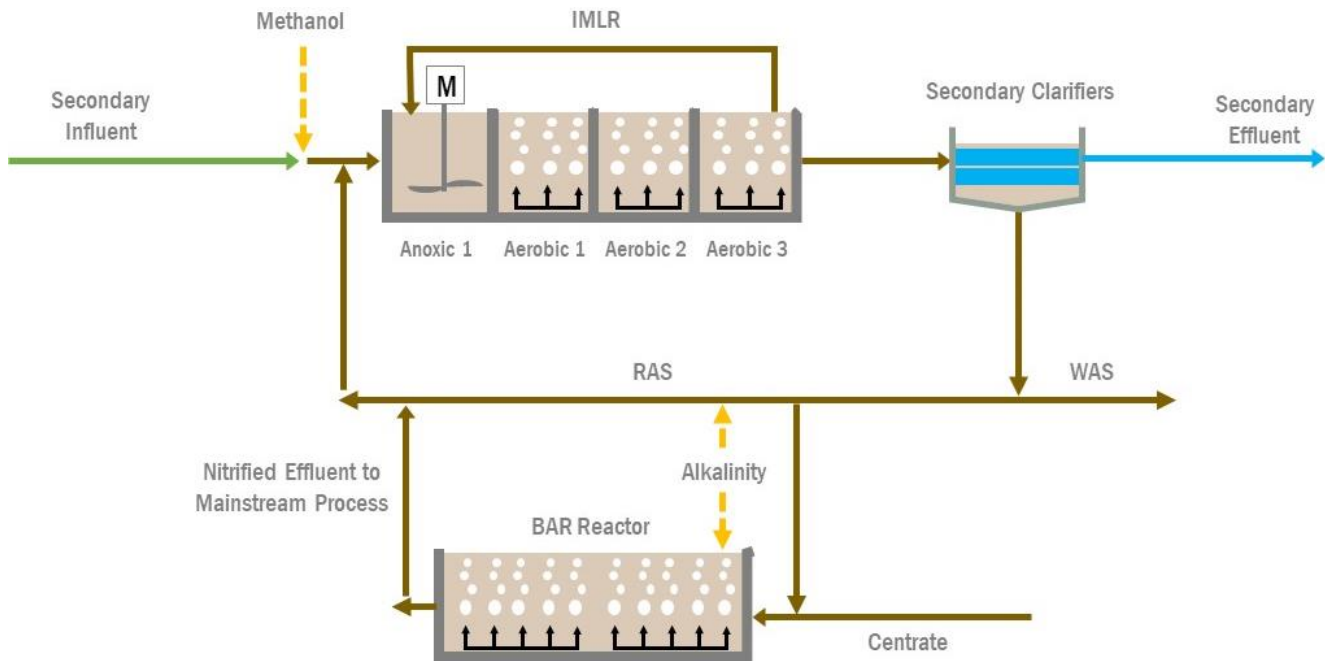

Figure 8. Process flow schematic for Alternative 4C – MLE + sidestream bioaugmentation

Table 17 summarizes the modeling results and sizing of major facilities and equipment for Alternative 4C. For this alternative, process modeling showed that the maximum month flow capacity would be reduced from the current rated value of 215 mgd to 105 mgd, corresponding to a loss of approximately 50 percent of the rated capacity. The increase in capacity relative to Alternative 4A is a result of sidestream bioaugmentation allowing nitrification at a slightly lower SRT.

Table 17. West Point Nitrogen Removal Modeling Results and System Sizing for Alternative 4C	
Parameter	Value
Maximum month flow capacity, mgd	105
Lost plant capacity (maximum month flow), mgd <sup>a</sup>	110
Secondary effluent TIN, mg/L	
@ Winter max month flow and load	9.0
@ summer avg dry weather flow and load	6.4
@ winter avg wet weather flow and load	8.6
Overall TN removal, % <sup>b</sup>	
@ Winter max month flow and load	57
@ summer avg dry weather flow and load	78
@ winter avg wet weather flow and load	62
Annual average	70
Annual average aeration requirements	
HPO gas, tons/day	-
Aeration basin air flow, scfm	25,500
Membrane scouring air flow, scfm	-
Annual average supplemental chemical requirements	
Alkalinity (25% caustic), gpd	7,850
Methanol, gpd	2,150
New aeration basins	
Number of new basins	2
Volume per basin, MG	2.35
Sidestream treatment	
Type	Bioaugmentation
No. of reactor tanks	1
Volume of reactor tanks, gal	750,000

a. Lost capacity based on the current rated maximum month flow capacity of 215 mgd.

b. Overall removal accounts for bypass around secondary treatment when flow exceeds 300 mgd.

A preliminary site layout for Alternative 4C is provided in Attachment A. The sidestream bioaugmentation reactor is assumed to be located just west of the secondary clarifiers. A variation of the layout is to retrofit an existing primary clarifier and convert it into the bioaugmentation reactor. This may be feasible as the reduced plant capacity would allow taking one or more primary clarifiers out of service. This alternative has similar **challenges and potential risks** as Alternatives 4A. Table 18 summarizes the estimated GHG emissions for Alternative 4C.

Table 18. West Point GHG Emissions for Alternative 4C	
Parameter	Value
GHG emissions (CO <sub>2</sub> e MT/yr)	
Nitrous oxide	2,200
Energy	150
Chemicals	9,200
Total	11,500

### 3.4.3 Alternative 4D – 4SMB + Sidestream Anammox

In this alternative, the existing HPO process is converted to a 4SMB-CAS process. See Section 3.2.3 for description of the 4SMB process. In addition, a sidestream anammox system is added to reduce nitrogen loading from the centrate stream. Figure 9 shows a process flow schematic for this alternative.

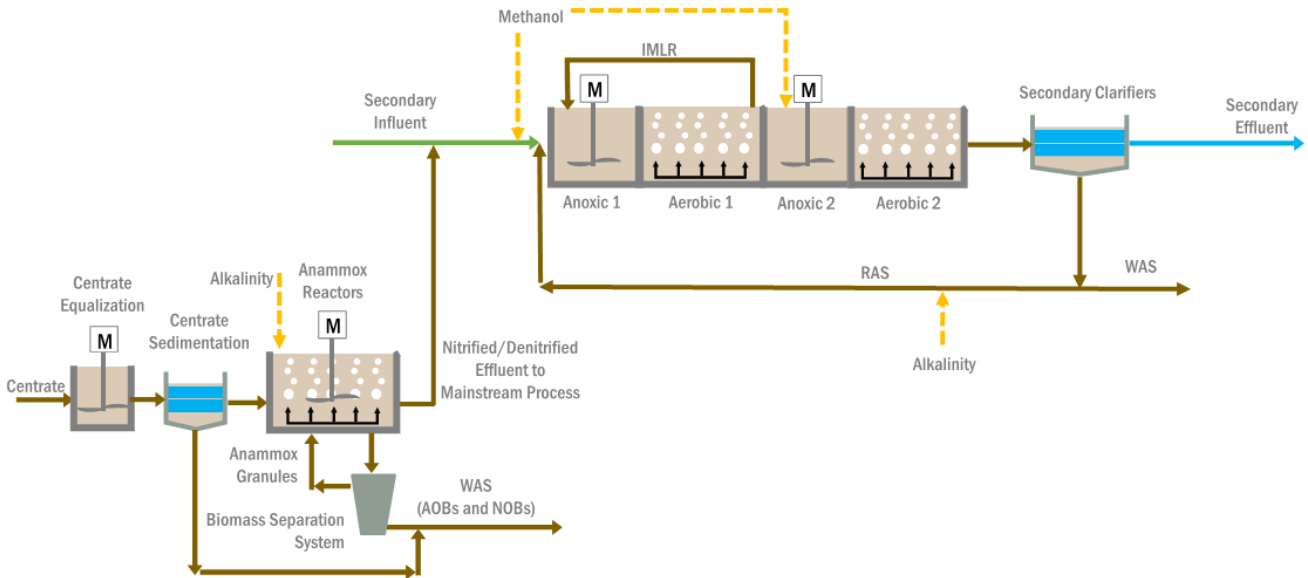

Figure 9. Process flow schematic for Alternative 4D – 4SMB + sidestream anammox

Table 19 summarizes the modeling results and sizing of major facilities and equipment for Alternative 4D. For this alternative, process modeling showed that the maximum month flow capacity would be reduced from the current rated value of 215 mgd to 105 mgd, the same as for Alternative 4C.

Table 19. West Point Nitrogen Removal Modeling Results and System Sizing for Alternative 4D	
Parameter	Value
Maximum month flow capacity, mgd	105
Lost plant capacity (maximum month flow), mgd <sup>a</sup>	110
Secondary effluent TIN, mg/L	
@ Winter max month flow and load	11
@ summer avg dry weather flow and load	2.9
@ winter avg wet weather flow and load	11
Overall TN removal, % <sup>b</sup>	
@ Winter max month flow and load	48
@ summer avg dry weather flow and load	88
@ winter avg wet weather flow and load	54
Annual average	70
Annual average aeration requirements	
HPO gas, tons/day	-
Aeration basin air flow, scfm	20,600
Membrane scouring air flow, scfm	-
Annual average supplemental chemical requirements	
Alkalinity (25% caustic), gpd	7,850
Methanol, gpd	860

Table 19. West Point Nitrogen Removal Modeling Results and System Sizing for Alternative 4D	
Parameter	Value
<b>New aeration basins</b>	
Number of new basins	2
Volume per basin, MG	2.35
<b>Sidestream treatment</b>	
Type	Anammox
Centrate equalization tank volume, gal	35,000
No. of reactor tanks	2
Volume of reactor tanks, gal	150,000

- a. Lost capacity based on the current rated maximum month flow capacity of 215 mgd.
- b. Overall removal accounts for bypass around secondary treatment when flow exceeds 300 mgd.

A preliminary site layout for Alternative 4D is provided in Attachment A. The layout for this alternative is similar to that for Alternative 4C (with the sidestream anammox system instead of the bioaugmentation system) located just west of the secondary clarifiers, and the existing and new aeration basins configured for the 4SMB process. This alternative has similar **challenges and potential risks** as Alternatives 4A. Table 20 summarizes the estimated GHG emissions for Alternative 4D.

Table 20. West Point GHG Emissions for Alternative 4D	
Parameter	Value
<b>GHG emissions (CO<sub>2</sub>e MT/yr)</b>	
Nitrous oxide	6,800
Energy	130
Chemicals	8,300
Total	15,300

### 3.4.4 Alternative 4E – 4SMB + Sidestream Bioaugmentation

This alternative is similar to alternative 4D, except that bioaugmentation is used for the sidestream process instead of anammox. Figure 10 shows a process flow schematic for this alternative.

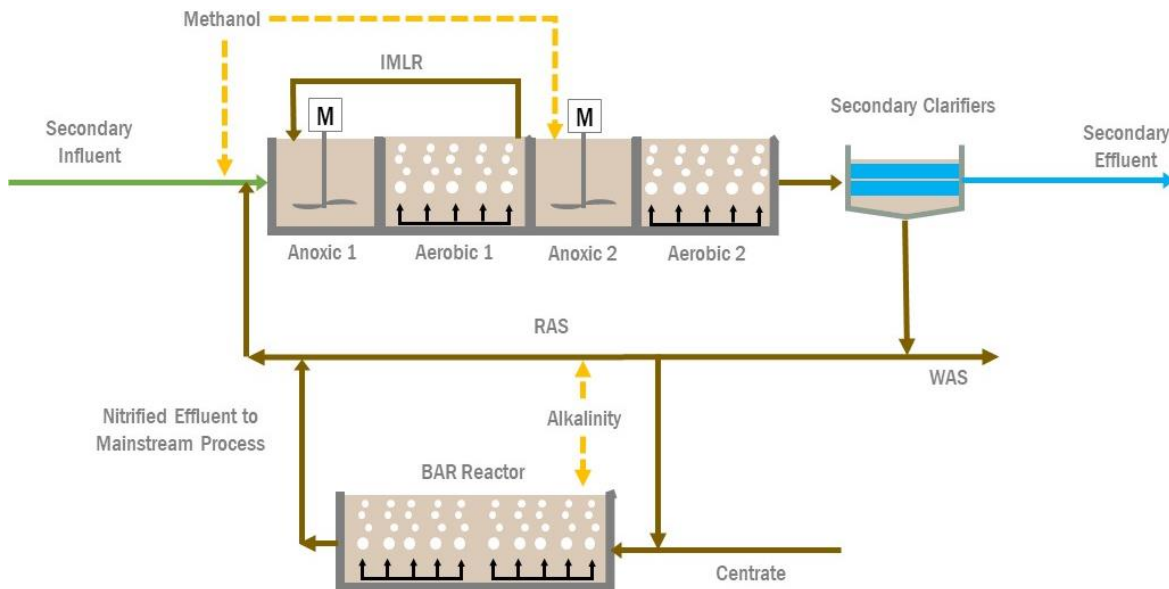

Figure 10. Process flow schematic for Alternative 4E – 4SMB + sidestream bioaugmentation

Table 21 summarizes the modeling results and sizing of major facilities and equipment for Alternative 4E. For this alternative, process modeling showed that the maximum month flow capacity would be reduced from the current rated value of 215 mgd to 107 mgd, similar to that for Alternative 4D. The slight increase in capacity for Alternative 4E relative to 4C, which also uses sidestream bioaugmentation, is a result of allowing the 4SMB process to operate in MLE mode during the winter at a higher effluent TIN concentration while operating in 4SMB mode during the summer at a lower effluent TIN concentration (but still maintaining the equivalent effluent TIN limit of 8 mg/L on an annual average basis).

Table 21. West Point Nitrogen Removal Modeling Results and System Sizing for Alternative 4E	
Parameter	Value
Maximum month flow capacity, mgd	107
Lost plant capacity (maximum month flow), mgd <sup>a</sup>	108
Secondary effluent TIN, mg/L	
@ Winter max month flow and load	11
@ summer avg dry weather flow and load	2.6
@ winter avg wet weather flow and load	11
Overall TN removal, % <sup>b</sup>	
@ Winter max month flow and load	48
@ summer avg dry weather flow and load	89
@ winter avg wet weather flow and load	54
Annual average	71
Annual average aeration requirements	
HPO gas, tons/day	-
Aeration basin air flow, scfm	26,800
Membrane scouring air flow, scfm	-
Annual average supplemental chemical requirements	
Alkalinity (25% caustic), gpd	7,950
Methanol, gpd	1,750
New aeration basins	
Number of new basins	2
Volume per basin, MG	2.35
Sidestream treatment	
Type	Bioaugmentation
No. of reactor tanks	1
Volume of reactor tanks, gal	750,000

<sup>a</sup> Lost capacity based on the current rated maximum month flow capacity of 215 mgd

<sup>b</sup> Overall removal accounts for bypass around secondary treatment when flow exceeds 300 mgd

A preliminary site layout for Alternative 4E is provided in Attachment A. The layout for this alternative is similar to that for Alternative 4D, with bioaugmentation instead of anammox sidestream system located just west of the secondary clarifiers. This alternative has similar **challenges and potential risks** as Alternatives 4A. Table 22 summarizes the estimated GHG emissions for Alternative 4E.

Table 22. West Point GHG Emissions for Alternative 4E	
Parameter	Value
GHG emissions (CO <sub>2</sub> e MT/yr)	
Nitrous oxide	6,700
Energy	160
Chemicals	9,000
Total	15,900



## Section 4: Cost Analysis

Cost analysis included development of capital, operations and maintenance (O&M), and life-cycle costs. This section discusses the assumptions and results of the cost analysis for scenario 1 through 3 alternatives. The results for scenario 4 alternatives are not included, as those alternatives would require a greenfield treatment plant to be constructed elsewhere to make up for the lost capacity at West Point; therefore, a direct comparison of scenario 4 alternatives cannot be made with the other alternatives. Results of the cost analysis for scenario 4 alternatives are provided in Attachment E.

### 4.1 Capital Costs

Capital costs were developed as pre-Class 5 conceptual cost estimates to provide order-of-magnitude costs. In accordance with WTD estimating guidelines and direction, long-range planning estimated capital project costs developed prior to the more immediate near-term timeline of a class 5 estimate have an anticipated range of -50 percent to +300 percent (or greater) relative accuracy. As part of the WTD estimate development process, various allowances, including allowances for indeterminates (undefined requirements), construction change orders, and project contingencies were included based on Class 5 cost estimating guidelines. Each estimate provides similar documentation to that of the Association for the Advancement of Cost Engineering international Guidelines and Recommended Practice for a Class 5 estimate and is further supported by recommended practices of WTD planning-level cost estimates.

For each alternative, a total project cost was developed, which includes raw construction costs, contractor markups, allowance for change order, sales tax, design and construction consulting fees, permitting, WTD staffing, contingency, and other indirect costs. Detailed descriptions of the basis and assumptions used in developing the project cost for each alternative are provided in the Basis of Estimates documents in Attachment C.

#### 4.1.1 Site-Specific Capital Cost Assumptions

Besides general cost estimating assumptions given in the Basis of Estimates, a number of plant-specific and alternative-specific assumptions were also used. These include:

- For all alternatives except Alternative 1, water staging was assumed via barge and temporary dock.
- For all alternatives except Alternative 1, allowances for archeological services during excavation, site mitigation, and compensation per tribal agreements for potential impact to fishing and shellfish harvests were included.
- For all alternatives except Alternative 1, new aeration basins will be constructed in the area northeast of the existing HPO basins. Costs were included for extending an existing 132-inch pipe from the Fort Lawton tunnel to allow construction of the new basins, and for extending the existing retaining wall on the south side of the basins.
- For all alternatives except Alternative 1, a new 30-space parking garage was assumed.
- For the scenario 2 and 3 alternatives (2A, 2B, 2C, 3A and 3D), an allowance for plant electrical system upgrades was included to meet the large increase in energy demand as a result of the full or partial conversion to MBR secondary treatment, compared to the energy demand of the existing HPO system.
- For all alternatives except Alternative 1, it was assumed that four to five aeration blowers will be added to replace the existing oxygen generation system for aeration. The number of blowers may be increased to reduce the size of each blower. Blower sizing should be further evaluated during design.
- No new odor control facilities were assumed to be added as part of the upgrades for each alternative. The existing aeration basins are not equipped with any odor control facilities.
- Costs for solids system upgrades were not included in this analysis. For scenario 2 and 3 alternatives, upgrades to the thickening system may be required to process the screenings from the PE fine screens



and WAS from the air-activated sludge system. The higher WAS production rates for those alternatives, compared with those for Alternative 1 as well as the existing condition, also means higher solids loading rates to the digesters. As the digesters are currently approaching capacity based on results of the Flows and Loads project capacity analysis, the need for digester upgrade will occur sooner for scenario 2 and 3 alternatives.

- There may be active bald eagle nests in the area that are regulated. This could result in construction restrictions during nesting season and impact construction sequencing and the implementation schedule. This was assumed to be at least partly accounted for in the complexity factor described below.
- Complexity factors serve as adjustments to the WTD allied/indirect costs. The factors range from low, to routine, moderate, and high. For West Point, due to the many anticipated construction and permitting challenges for plant expansion, moderate or high complexity factors were assumed for many of the indirect cost categories, especially for Scenario 2 and 3 alternatives.

#### **4.1.2 Summary of Capital Costs**

Table 23 summarizes the capital costs for the scenario 1 through 3 alternatives.

**Table 23. Summary of Capital Costs for West Point Alternatives (Scenarios 1 through 3) <sup>a</sup>**

Alternatives	Estimated probable cost of construction bid	Other construction cost	Total direct construction cost	Total indirect non-construction cost	Total Project Cost	Total project cost range	
						Low (-50 percent)	High (+300 percent)
Alt 1: Existing mainstream + sidestream anammox	\$35,850,000	\$7,650,000	\$43,500,000	\$45,110,000	\$88,610,000	\$44,310,000	\$354,440,000
Alt 2A: MLE/MBR	\$1,245,270,000	\$265,620,000	\$1,510,890,000	\$1,319,750,000	\$2,830,640,000	\$1,415,320,000	\$11,322,560,000
Alt 2B: MLE/MBR + sidestream anammox	\$1,271,360,000	\$271,180,000	\$1,542,540,000	\$1,345,300,000	\$2,887,840,000	\$1,443,920,000	\$11,551,360,000
Alt 2C: 4SMB/MBR + sidestream anammox	\$1,258,650,000	\$268,470,000	\$1,527,120,000	\$1,332,860,000	\$2,859,980,000	\$1,429,990,000	\$11,439,920,000
Alt 3A: MLE/MBR + sidestream anammox	\$740,600,000	\$157,970,000	\$898,570,000	\$801,120,000	\$1,699,690,000	\$849,850,000	\$6,798,760,000
Alt 3D: 4SMB/MBR + sidestream anammox	\$742,340,000	\$158,340,000	\$900,680,000	\$802,850,000	\$1,703,540,000	\$851,770,000	\$6,814,160,000

a. Unescalated, undiscounted costs in 2020 dollars..

## 4.2 O&M Costs

O&M costs consist of power, chemical, and labor costs. Other O&M costs, including material and equipment replacement and other maintenance costs, are assumed to be insignificant compared to power, chemical and additional labor costs, or the differences for those costs among alternatives are expected to be insignificant. Only O&M costs associated with primary effluent fine screening (if added), secondary system, and sidestream processes are included in this cost analysis. Electrical costs for motorized equipment were calculated from motor horsepower data provided by the equipment vendors or estimated from process modeling results. Labor costs were calculated from the additional full-time equivalents (FTEs) expected for the liquid-stream upgrades determined for each alternative.

### 4.2.1 Site-Specific O&M Cost Assumptions

Plant-specific and alternative-specific O&M cost assumptions include:

- For Alternative 1, power consumption of the existing HPO aerators and oxygen generation facility was provided by WTD based on existing operation.
- Electrical costs were calculated from a blended rate provided by WTD for West Point. Blended rate accounts for both costs based on a unit rate (dollar per kilowatt-hour [\$/kWh]) and demand charges. The blended rate calculated from 6 months of data in 2019 was \$0.0781/kWh.
- Alkalinity control is provided by adding 25 percent caustic solution. Unit cost for the caustic solution was based on data provided by WTD for the Brightwater operation, at \$0.067 per pound or \$0.72 per gallon. A unit cost of \$0.75 per gallon was assumed to account for some potential price variability. Including a 10.1 percent sales tax, a unit cost of \$0.83 per gallon was used.
- Methanol cost is \$2.42 per gallon based on a budgetary unit cost of \$2.20 per gallon provided by Cascade Columbia and 10.1 percent sales tax.
- Costs for sodium hypochlorite and citric acid were included for scenario 2 and 3 alternatives as they are added for membrane cleaning. Annual average consumption rates of each chemical were provided by the MBR supplier (Suez). Unit costs of \$0.95 per gallon and \$13.66 per gallon were assumed for 12.5 percent sodium hypochlorite solution and 50 percent citric acid solution, respectively, both based on data provided by WTD for existing Brightwater operation and including 10.1 percent sales tax.
- Labor costs for additional FTEs were estimated based on an annual cost of \$204,000 per FTE provided by WTD, which includes salary and overhead costs.

### 4.2.2 Summary of O&M Costs

Table 24 summarizes the O&M costs for the scenario 1 through 3 alternatives.

Alternatives	Annual electricity cost	Annual chemical cost	Annual additional FTE cost	Total annual O&M costs
Alt 1: Existing mainstream + sidestream anammox	\$1,820,000	-	\$102,000	\$1,922,000
Alt 2A: MLE/MBR	\$8,060,000	\$11,846,000	\$816,000	\$20,722,000
Alt 2B: MLE/MBR + sidestream anammox	\$8,063,000	\$10,227,000	\$918,000	\$19,208,000
Alt 2C: 4SMB/MBR + sidestream anammox	\$7,780,000	\$9,317,000	\$1,020,000	\$18,117,000
Alt 3A: MLE/MBR + sidestream anammox	\$3,687,000	\$5,868,000	\$1,122,000	\$10,677,000
Alt 3D: 4SMB/MBR + sidestream anammox	\$3,593,000	\$5,133,000	\$1,224,000	\$9,950,000

a. Unescalated, undiscounted costs in 2020 dollars. Only electrical, chemical, and additional FTE costs for primary effluent fine screening (if added), secondary system, and sidestream processes are included.

## 4.3 Life–Cycle Costs

LCCA was performed to estimate the total net present value (NPV) of the capital and O&M costs over a 20-year life-cycle period. The following assumptions were used in the LCCA:

- Capital costs were assumed to be distributed over a 5-year period starting in 2030, representing a cashflow from design to construction completion as follows:
  - 5 percent in year 1
  - 10 percent in year 2
  - 25 percent in year 3
  - 40 percent in year 4
  - 20 percent in year 5
- O&M costs were included for the 20-year period from 2035 to 2054.
- Capital and O&M costs were escalated from the 2020 costs to the design year using an escalation rate of 3 percent.
- The escalated costs were then discounted back to the NPV in 2020 dollars using a discount rate of 5.25 percent.

Table 25 summarizes the life-cycle costs for the scenario 1 through 3 alternatives, as well as the total nitrogen load removed over the 20-year life-cycle period and the cost per pound of nitrogen removed.

Alternatives	Capital costs <sup>a</sup>	O&M costs <sup>a</sup>	NPV	TN removed (lb) <sup>b</sup>	Cost per lb N removed <sup>c</sup>
Alt 1: Existing mainstream + sidestream anammox	\$88,610,000	\$38,440,000	(\$90,320,000)	43,606,300	\$2.07
Alt 2A: MLE/MBR	\$2,830,640,000	\$414,430,000	(\$2,402,480,000)	161,247,200	\$14.90
Alt 2B: MLE/MBR + sidestream anammox	\$2,887,840,000	\$384,140,000	(\$2,428,080,000)	163,127,800	\$14.88
Alt 2C: 4SMB/MBR + sidestream anammox	\$2,859,980,000	\$362,330,000	(\$2,393,920,000)	190,382,000	\$12.57
Alt 3A: MLE/MBR + sidestream anammox	\$1,699,690,000	\$213,550,000	(\$1,421,650,000)	118,710,600	\$11.98
Alt 3D: 4SMB/MBR + sidestream anammox	\$1,703,540,000	\$198,990,000	(\$1,415,940,000)	131,116,300	\$10.80

a. Unescalated, undiscounted costs in 2020 dollars.

b. Total nitrogen load removed calculated from the difference between the annual raw influent TKN load and plant effluent nitrogen load, both based on current rated plant influent flows and loadings, multiplied by 20 for the 20-year life-cycle period.

c. Cost per lb N removed calculated by dividing the 20-year NPV by the total N removed.

## Section 5: Comparison and Ranking of Alternatives

Based on the preliminary site layouts, capital costs, O&M costs, and LCCA results presented above, the alternatives were evaluated using various pre-selected criteria. The preliminary results were presented and discussed with WTD staff in the December 5, 2019 workshop (Workshop 2). The final results incorporate comments from WTD. The following sections provide a summary of the evaluation criteria and results.

### 5.1 Evaluation Criteria and Weighting

Alternatives were compared against both economic and non-economic criteria. Most of these criteria were used in the initial screening of nitrogen removal technologies and in selecting the technology combination alternatives evaluated in this analysis. For evaluation of the final alternatives, a weighting factor was

assigned to each criterion. The weighting factor can range from 1 to 3, with 3 representing the highest weight. For each evaluation criteria, a score ranging from 1 to 10 was assigned to each alternative. The weighted score for that criterion was then calculated as the product of the raw score and the weighting factor. The following provides a summary of the criteria and weighting factors used for this analysis.

### **5.1.1 Technology Status**

Technology status refers to how well-established the technology is in the industry. During the technology screening process, all embryonic technologies (those that have only recently started full-scale installation within the last year or have only in-laboratory or pilot-scale installations) were screened out. As all technologies selected for the final alternatives are considered established, a weighting factor of 1 was used for this evaluation criterion.

### **5.1.2 Effluent Nitrogen Load Reduction**

Effluent nitrogen load reduction refers to the total nitrogen load removed across the liquid-stream processes. In the analysis, the TN load removed over a 20-year period was calculated for each alternative. The alternative with the highest TN load removed was assigned a score of 10; scores for the other alternatives were estimated relative to that highest TN load removed. As this is considered an important evaluation criterion, a weighting factor of 3 was assigned.

### **5.1.3 Load Variation Impact**

Load variation impact refers to the impact of or ability to handle large variations in load either throughout the day or during storm events. For West Point, load variation impact is expected to be the same for all alternatives; therefore, a weighting factor of 1 was assigned.

### **5.1.4 Flow Variation Impact**

Flow variation impact refers to the impact of or ability to handle large variations in flow either throughout the day or during storm events. As West Point can experience high flow during storm events, this is a more important criterion than load variation impact. A weighting factor of 2 was assigned.

### **5.1.5 Space for Future Expansion**

Space for future expansion refers to space available for future plant expansion after construction of the new and modified facilities for each alternative. As this is an important evaluation criterion, a weighting factor of 3 was assigned.

### **5.1.5 Impacts to Other Processes**

This criterion refers to potential impacts to other treatment processes within the WWTP. For this analysis, the impacts were mainly based on total solids production rates, which affect the capacity requirements for the solids treatment processes. A weighting factor of 2 was assigned for this criterion.

### **5.1.6 Truck Traffic**

This criterion refers to the increase in number of trucks entering and leaving a facility. These trucks could be for additional biosolids generated by the alternative or increased chemical delivery. Scoring of each alternative was thus based on a combination of both biosolids production and chemical demands. A weighting factor of 2 was assigned for this criterion.

### **5.1.7 GHG Emissions**

This criterion refers to the GHG emissions estimated from energy and chemical usage and nitrous oxide emissions from denitrification processes. A weighting factor of 2 was assigned for this criterion.

### 5.1.8 Resource Recovery

Resource recovery options include nutrient recovery (nitrogen or phosphorus), flexibility for future reclaimed water production, and energy recovery. For reclaimed water production, alternatives that include membrane or tertiary filtration or have low TN limits (thus allowing groundwater recharge) would have a higher score. As resource recovery is considered a less-important evaluation criterion for this analysis, a weighting factor of 1 was assigned.

### 5.1.9 CEC and Toxics Removal Potential

Compounds of emerging concern (CEC) and toxics removal potential refers to the ability of the treatment processes to remove CEC and toxics. For this analysis, only removals across the mainstream activated sludge process was considered. In general, longer SRT systems (such as the MBR) have higher potential removal, while blended treatment (such as the parallel MBR/CAS processes) or alternatives with seasonal nitrogen removal have lower potential removal. A weighting factor of 1 was assigned to this criterion.

### 5.1.10 Capital Cost

Capital costs refer to the total project costs provided in Table 23. Alternative 1, with the least amount of capital improvements and thus the lowest project costs, was assigned a score of 10. Scoring of the other alternatives was made mainly by comparing alternatives within each scenario, and not strictly based on the capital costs for each alternative relative to the capital cost for Alternative 1. A weighting factor of 3 was assigned to this criterion.

### 5.1.11 O&M Cost

O&M costs include costs for energy use, chemical consumption, and increased labor (FTEs) associated with the mainstream and sidestream processes considered in this evaluation, as shown in Table 24. Alternative 1, with the lowest O&M cost, was assigned a score of 10. Scoring of the other alternatives was made mainly by comparing alternatives within each scenario, and not strictly based on the O&M costs for each alternative relative to the O&M costs for Alternative 1. A weighting factor of 3 was assigned to this criterion.

### 5.1.12 Supplementary Carbon Source Flexibility

Supplemental carbon source flexibility refers to the potential of the process to use alternatives to purchased external supplemental carbon sources for denitrification. Common external supplemental carbon sources for denitrification include methanol and acetic acid. This analysis assumed methanol as the supplemental carbon source for all alternatives to provide a baseline for costing and comparison between alternatives. To reduce operating costs associated with purchase of supplemental carbon, it may also be possible to use a carbon source that is generated internally to the plant through fermentation processes, such as primary sludge fermentation. However, primary sludge fermentation would require additional upgrades and infrastructure for the fermentation facilities. In addition, primary sludge fermentation will release additional nitrogen that would be added to the treatment process. For this evaluation, all alternatives considered would be compatible with using primary sludge fermentate in lieu of methanol as the supplemental carbon source or to reduce methanol requirements. However, because fermentate contributes an additional nitrogen load, it may have limitations for adding in a second anoxic zone of a 4SMB process when trying to achieve very low effluent TIN limits (e.g., 3 mg/L). In addition, primary sludge fermentation can reduce the relative benefit of sidestream nitrogen removal because of the reduction in nitrogen loading to sidestream treatment in the centrate (nitrogen released through fermentation is recycled to the secondary treatment process rather than being released in anaerobic digestion where the nitrogen would be available for removal with sidestream treatment). Therefore, alternatives with a 4SMB process or sidestream treatment were assigned slightly lower scores for supplemental carbon source flexibility. A weighting factor of 2 was assigned to this criterion.

### **5.1.13 Risks**

The risks criterion was added to account for potential risks not already captured as part of the other scoring criteria, such as risks associated with requiring a new electrical service to the plant (alternatives with a significantly increased electrical load) or reduced membrane flux/permeability restricting secondary treatment capacity (MBR alternatives). Potential risks for each alternative are listed in the notes on the preliminary site layouts in Attachment A. They are also described in the description of each alternative in Section 3. A weighting factor of 2 was assigned to this criterion.

### **5.1.14 Constructability**

Constructability refers to the ease of building while minimizing impacts to facility operation and the ability to meet current permit limits. In general, alternatives with higher footprint requirements will have a lower score for constructability. A weighting factor of 3 was assigned to this criterion.

### **5.1.15 Operational Complexity**

Operational complexity refers to the ease of operating and maintain the process. For example, a conventional system expansion that uses technology similar to West Point's current process (i.e., aerators and oxygen-generation equipment for the HPO process) would have low operational complexity and be given a higher score. A process that requires significantly more equipment for maintenance, equipment that requires more frequent maintenance, or a process that is more complex to operate and requires additional instrumentation or monitoring to ensure process stability would be given a lower score. A weighting factor of 2 was assigned to this criterion.

## 5.2 Evaluation Results

To facilitate comparison of alternatives, the modeling, LCCA, and GHG emissions results for the secondary and sidestream treatment process for scenario 1 through 3 alternatives are summarized in Table 26; a comparative plot of GHG emissions is shown on Figure 11. For comparison, Figure 11 and Table 26 also show GHG emissions and nitrogen removal performance for the base case, which is defined as similar to Alternative 1 but without sidestream anammox. In general, the greater amount of nitrogen removed, the higher the GHG emissions. It is worth noting that the GHG emissions for production of the electricity supplied to West Point are relatively low compared to most locations in the United States. The dramatic increase in electricity required for the MBR alternatives would have an even more pronounced increase in GHG emissions in most other parts of the United States. The results for scenario 4 alternatives are not included, as those alternatives would require a greenfield treatment plant to be constructed elsewhere to make up for the lost capacity at West Point; therefore, a direct comparison of scenario 4 alternatives cannot be made with the other alternatives. Results of scenario 4 alternatives, including scoring for the evaluation criteria, are provided in Attachment E. Scoring of scenario 1 through 3 alternatives is summarized on Figure 12.

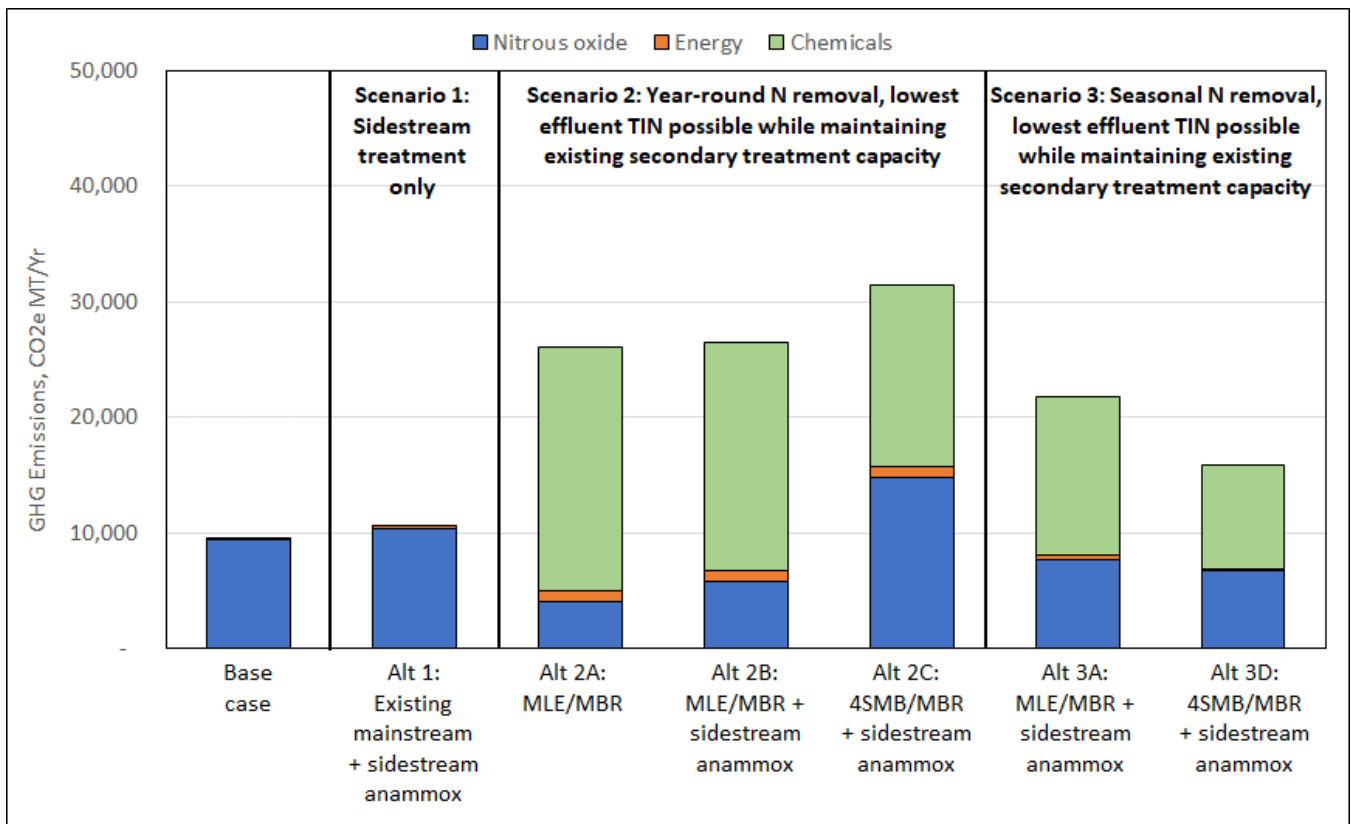

**Figure 11. Comparison of estimated GHG emissions (scenarios 1 through 3)**

*The base case is assumed to be the same as Alternative 1 without sidestream anammox.*



**Table 26. Comparison of Alternatives – Modeling and LCCA Results (Scenarios 1 through 3)**

Alternative		Base case <sup>a</sup>	1	2A	2B	2C	3A	3D
Scenario modifications or effluent limits/targets		-	Sidestream treatment only	Year-round N removal, lowest effluent TIN possible while maintaining existing secondary treatment capacity			Seasonal N removal, lowest effluent TIN possible while maintaining existing secondary treatment capacity	
Alternative description		Existing mainstream	Existing mainstream + sidestream anammox	MLE/MBR	MLE/MBR + sidestream anammox	4SMB/MBR + sidestream anammox	MLE/MBR + sidestream anammox	4SMB/MBR + sidestream anammox
Parameter	Units	Value						
<b>Cost estimates and LCCA results</b>								
Capital cost (total project cost) <sup>b</sup>	-	-	\$88,610,000	\$2,830,640,000	\$2,887,840,000	\$2,859,980,000	\$1,699,690,000	\$1,703,540,000
O&M cost (20-year) <sup>b, c</sup>	-	-	\$38,440,000	\$414,430,000	\$384,140,000	\$362,330,000	\$213,550,000	\$198,990,000
NPV (20-year)	-	-	(\$90,320,000)	(\$2,402,480,000)	(\$2,428,080,000)	(\$2,393,920,000)	(\$1,421,650,000)	(\$1,415,940,000)
Power consumption	kWh/yr	-	23,303,700	103,199,700	103,233,000	99,617,200	47,212,500	46,002,600
<b>Anticipated performance</b>								
Lost plant capacity (peak month flow)	mgd	-	-	-	-	-	-	-
Effluent TIN, summer average	mg/L	31.1	27.3	7.0	6.9	2.8	7.0	2.5
Effluent TIN, winter average	mg/L	21.7	19.3	6.9	6.6	2.8	16.5	16.5
TN removal efficiency, summer average	-	12%	22%	78%	78%	89%	77%	89%
TN removal efficiency, winter average	-	10%	18%	70%	71%	85%	33%	33%
TN removal efficiency, annual average	-	10%	20%	74%	75%	87%	54%	60%
TN removed, annual average	lb/d	3,148	5,973	22,089	22,346	26,080	16,262	17,961
TN removed over 20-year period	lb	22,980,100	43,606,300	161,247,200	163,127,800	190,382,000	118,710,600	131,116,300
Cost of N removal <sup>d</sup>	\$/lb N	-	\$2.07	\$14.90	\$14.88	\$12.57	\$11.98	\$10.80
<b>Biosolids impacts</b>								
WAS production, peak month	lb TSS/d	98,055	96,380	119,749	108,374	111,988	108,823	110,199
Biosolids production, peak month	DT/d	43	43	49	47	47	51	51
<b>Sustainability analysis results</b>								
GHG emissions, nitrous oxide	CO <sub>2</sub> e MT/yr	9,400	10,400	4,100	5,800	14,800	7,700	14,100
GHG emissions, energy	CO <sub>2</sub> e MT/yr	200	210	920	920	890	420	410
GHG emissions, chemicals	CO <sub>2</sub> e MT/yr	0	0	21,100	19,700	15,700	13,700	11,600
GHG emissions, total	CO <sub>2</sub> e MT/yr	9,600	10,600	26,100	26,400	31,400	21,800	26,100
<b>Other considerations</b>								
Implementation timeframe <sup>e</sup>	-	-	5–7 years	8–10 years	8–10 years	8–10 years	8–10 years	8–10 years
Site layout issues/constraints	-	-	See notes on site layouts.					
Implementation challenges or constructability considerations	-	-						

a. The base case is assumed to be the same as Alternative 1 without sidestream anammox.

b. Capital and O&M costs are presented in 2020 dollars.

c. O&M costs are for electricity, chemicals, and additional FTEs only.

d. Cost of N removal calculated as TN removed over 20-year period divided by 20-year NPV.

e. Estimated duration for planning, design, and construction.

DT = dry tons

Alternative		1	2A	2B	2C	3A	3D
Scenario modifications or effluent limits/targets		Sidestream treatment only	Year-round N removal, lowest effluent TIN possible while maintaining existing secondary treatment capacity			Seasonal N removal, lowest effluent TIN possible while maintaining existing secondary treatment capacity	
Alternative description		Existing mainstream + sidestream anammox	MLE/MBR	MLE/MBR + sidestream anammox	4SMB/MBR + sidestream anammox	MLE/MBR + sidestream anammox	4SMB/MBR + sidestream anammox
Scoring criteria	Weight <sup>b</sup>	Score <sup>a</sup>					
Technology status	1	10	8	8	8	10	10
Effluent N load reduction	3	2	8	8	10	6	7
Load variation impact	1	6	6	6	6	6	6
Flow variation impact	2	6	2	2	2	4	4
Space for future expansion	3	9	3	2	2	1	1
Plant capacity	3	10	8	8	8	7	7
Impacts to other processes	2	10	6	6	6	6	6
Truck traffic	2	10	1	2	3	4	5
GHG emissions	2	9	4	4	3	5	4
Resource recovery <sup>c</sup>	1	1	7	7	8	5	6
CEC and toxics removal potential <sup>d</sup>	1	1	8	8	8	5	5
Capital cost	3	9	3	1	2	6	5
O&M cost	3	9	1	3	4	5	7
Supplemental carbon source flexibility	2	5	5	4	3	4	3
Risks	2	10	1	1	1	5	5
Constructability	3	10	1	1	1	3	3
Operational complexity	2	8	2	1	1	4	3
<b>Total un-weighted score</b>		<b>125</b>	<b>74</b>	<b>72</b>	<b>76</b>	<b>86</b>	<b>87</b>
<b>Total weighted score</b>		<b>281</b>	<b>143</b>	<b>138</b>	<b>149</b>	<b>174</b>	<b>177</b>
Notes:							
a. Score of 1 to 10, where 10 represents the greatest benefit or lowest cost, footprint, emissions, etc.							
b. Score of 1 to 3, where 3 represents the highest weighting factor.							
c. Resource recovery includes nutrient recovery (N or P), flexibility for future reclaimed water production (TN limits, filtration, etc.), energy recovery, etc.							
d. CEC and toxics removal potential only considers the mainstream activated sludge process. In general, longer SRT systems (MBR) have higher potential removal, while blended options (parallel MBR/CAS systems) or seasonal N removal options have lower potential.							

Figure 12. Comparison of alternatives—scoring results (scenarios 1 through 3)

## Section 6: Summary

Rather than selecting preferred alternatives for each nitrogen removal scenario, the task team decided during Workshop 2 that the evaluation results would be most beneficial if used to represent a range of potential costs for each scenario; this approach recognizes that future alternatives analyses would be required during planning and design to select the preferred upgrade approach for West Point once actual nitrogen limits and the timing of nitrogen limits are known. Overall, key conclusions from the West Point analysis of planning alternatives include:

- Retaining the existing mainstream treatment process and adding sidestream nitrogen removal (anammox) (scenario 1) would provide the lowest overall cost of nitrogen removal. However, the addition of sidestream treatment alone only reduces the average annual TIN by about 3 mg/L from the base case and may not be capable of achieving expected potential effluent TIN limits, either on a seasonal or year-round basis. Scenario 1 may be preferable for West Point because of its considerable site limitations and difficulties with implementing large construction projects. Sidestream treatment could be a precursor to mainstream nitrogen removal upgrades.
- It will be difficult for West Point to maintain existing secondary treatment capacity if year-round nitrogen limits are imposed (scenario 2), both from a site footprint perspective and cost perspective. Additionally, constructability of all options will be very difficult, likely requiring water staging, archeological survey, and extensive environmental restoration/mitigation. Maintaining secondary treatment capacity may not be possible for the entire duration of construction for some options, requiring secondary treatment bypass or alternate treatment elsewhere. Changes to the NPDES permit may be required to allow temporary partial or full bypass of the secondary system during construction. There are many other implementation challenges and potential risks for each alternative. Maintaining capacity under a seasonal nitrogen removal scenario (scenario 3) could be achieved by implementing two parallel secondary treatment processes (CAS and MBR) with sidestream anammox, thus reducing costs and potentially alleviating some of the constructability challenges of scenario 2. However, most of the challenges and risks would still apply, while adding operational complexity to simultaneously operate two separate treatment trains with different types of technologies.
  - Results suggest that it would be feasible to achieve a year-round average effluent TIN of 3 mg/L using a 4SMB/MBR process with sidestream anammox (Alternative 2C), while MLE/MBR with or without sidestream anammox (Alternatives 2A and 2B) could likely achieve a year-round average effluent TIN of 8 mg/L.
  - Capital costs of year-round nitrogen removal alternatives (scenario 2) are similar for all three alternatives, ranging from approximately \$2.83 to \$2.89 billion, and up to \$11.6 billion (+300 percent) based on the upper end of the cost estimate accuracy range.
  - The capital cost of seasonal nitrogen removal (scenario 3) is approximately \$1.70 billion and up to \$6.81 billion (+300 percent) based on the upper end of the cost estimate accuracy range. The capital cost is similar for the two alternatives considered.
- In terms of operational impacts on the secondary system, on average, scenario 2 alternatives would have the highest electricity demand and chemical requirements, while scenario 3 alternatives would have the highest additional labor requirements. Higher chemical requirements would mean increased truck traffic. GHG emissions would generally increase the most for scenario 2 alternatives, followed by scenario 3 alternatives, and the least for scenario 1.
- For both scenarios 2 and 3, the required secondary treatment facilities would consume all of the available footprint and only provide treatment for the existing capacity, limiting future capacity expansion.

- A full conversion to an MBR process for scenario 2 (with a peak flow of 300 mgd matching the current peak secondary treatment capacity) would make West Point the largest MBR facility in the United States (by over three times in design capacity based on current installations) and one of the largest MBR facilities in the world. Even for scenario 3, a parallel MBR treatment train would be more than twice the size of the current MBR system at Brightwater.
- Without conversion to MBR process (but still requiring conversion to an air activated sludge process), West Point can achieve year-round average effluent TIN of 8 mg/L only with reduced secondary treatment capacity. Expressed in terms of plant maximum month flow, the plant capacity would be reduced by approximately 50 percent from the current rated capacity of 215 mgd. That would mean that while allowing West Point to meet the target TIN limit, construction of a new WWTP would be required to accommodate the lost capacity of West Point, along with extensive modifications to the collection system. Consideration of collection system modifications or provisions for a new WWTP were beyond the scope of this study.
- All modeling and sizing conducted for this study was based on the current rated flows and loads for West Point. Further evaluation would be needed to assess impacts of operation at actual and projected flows and loads.

## Attachment A: Site Layouts

---





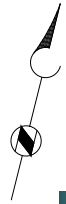

Site layout issues/constraints:  
 -Sidestream anammox location interferes with location of future secondary clarifiers

Implementation challenges or constructibility considerations:  
 -Can be constructed with minimal impacts to existing plant operations

Risks:  
 -Provides limited overall nitrogen removal

NEW SIDESTREAM ANAMMOX SYSTEM

NOTE: SITE LAYOUT DESIGNED FOR CURRENT PLANT RATED CAPACITY.



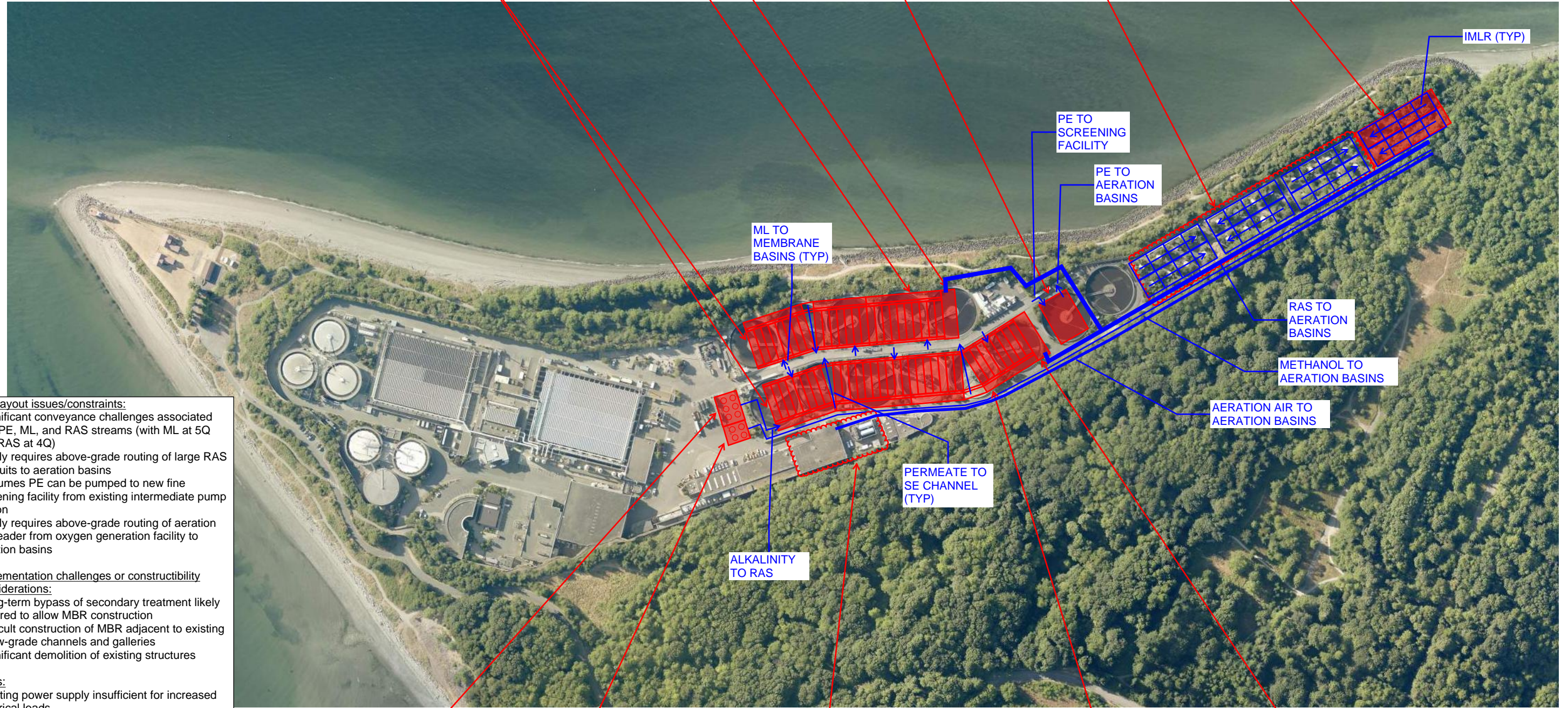

**Site layout issues/constraints:**

- Significant conveyance challenges associated with PE, ML, and RAS streams (with ML at 5Q and RAS at 4Q)
- Likely requires above-grade routing of large RAS conduits to aeration basins
- Assumes PE can be pumped to new fine screening facility from existing intermediate pump station
- Likely requires above-grade routing of aeration air header from oxygen generation facility to aeration basins

**Implementation challenges or constructibility considerations:**

- Long-term bypass of secondary treatment likely required to allow MBR construction
- Difficult construction of MBR adjacent to existing below-grade channels and galleries
- Significant demolition of existing structures

**Risks:**

- Existing power supply insufficient for increased electrical loads
- Membrane permeability lower than design value limits secondary treatment capacity (conservative flux limit used for site layout to reduce this risk)
- High operational complexity
- No available space for aeration basin expansion

NEW SUPPLEMENTAL ALKALINITY SYSTEM

NEW SUPPLEMENTAL METHANOL SYSTEM

EXISTING OXYGEN GENERATION FACILITY RETROFITTED FOR AERATION BLOWERS

SOUTH MEMBRANE EQUIPMENT GALLERY

SOUTH RAS PUMP STATION

NOTE: SITE LAYOUT DESIGNED FOR CURRENT PLANT RATED CAPACITY.



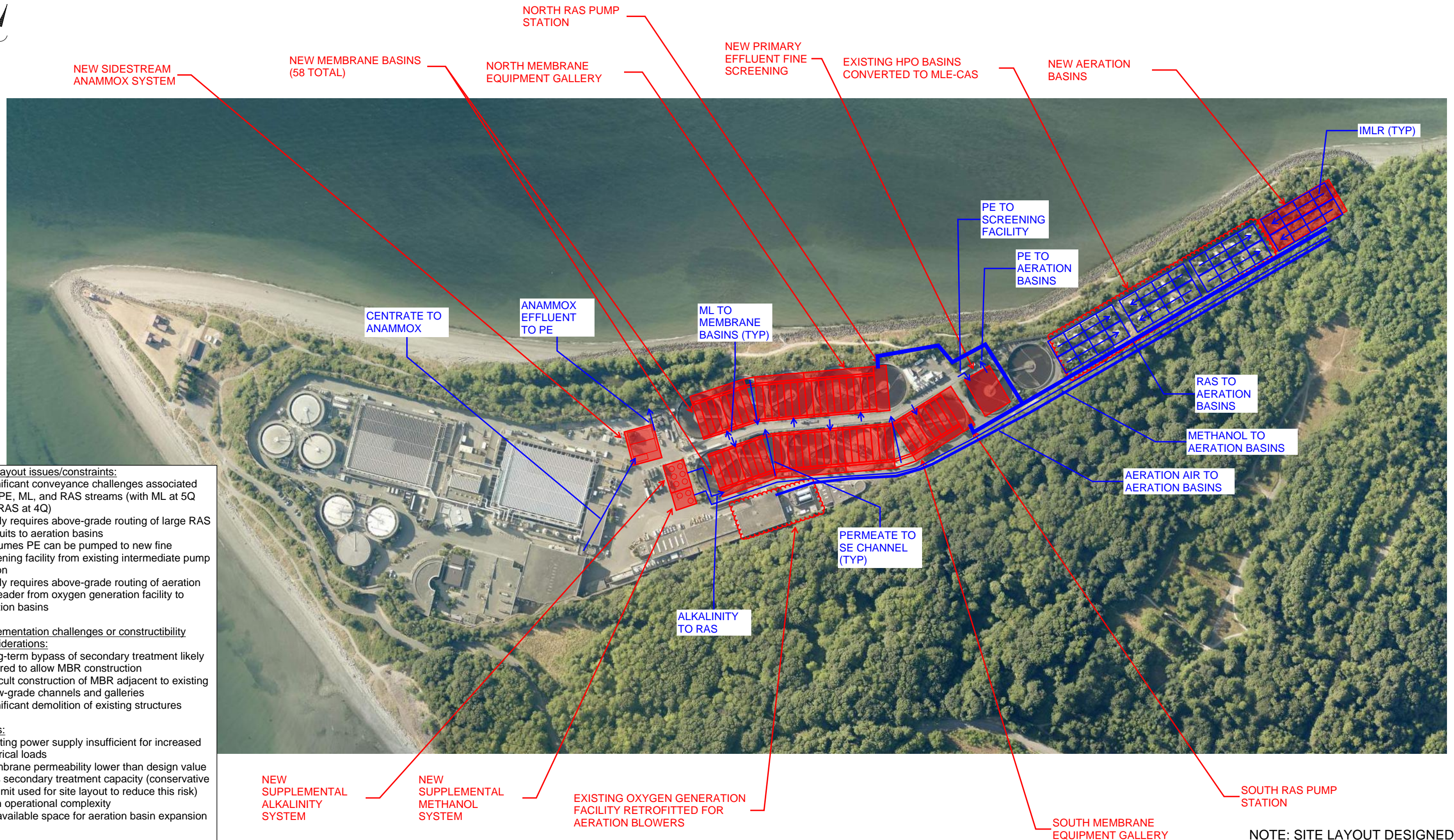

**Site layout issues/constraints:**

- Significant conveyance challenges associated with PE, ML, and RAS streams (with ML at 5Q and RAS at 4Q)
- Likely requires above-grade routing of large RAS conduits to aeration basins
- Assumes PE can be pumped to new fine screening facility from existing intermediate pump station
- Likely requires above-grade routing of aeration air header from oxygen generation facility to aeration basins

**Implementation challenges or constructibility considerations:**

- Long-term bypass of secondary treatment likely required to allow MBR construction
- Difficult construction of MBR adjacent to existing below-grade channels and galleries
- Significant demolition of existing structures

**Risks:**

- Existing power supply insufficient for increased electrical loads
- Membrane permeability lower than design value limits secondary treatment capacity (conservative flux limit used for site layout to reduce this risk)
- High operational complexity
- No available space for aeration basin expansion

NOTE: SITE LAYOUT DESIGNED FOR CURRENT PLANT RATED CAPACITY.





NEW SIDESTREAM ANAMMOX SYSTEM

NEW MEMBRANE BASINS (58 TOTAL)

NORTH MEMBRANE EQUIPMENT GALLERY

NORTH RAS PUMP STATION

NEW PRIMARY EFFLUENT FINE SCREENING

EXISTING HPO BASINS CONVERTED TO 4SMB-CAS

NEW AERATION BASINS

IMLR (TYP)

PE TO SCREENING FACILITY

PE TO AERATION BASINS

ANAMMOX EFFLUENT TO PE

ML TO MEMBRANE BASINS (TYP)

CENTRATE TO ANAMMOX

RAS TO AERATION BASINS

METHANOL TO AERATION BASINS

AERATION AIR TO AERATION BASINS

PERMEATE TO SE CHANNEL (TYP)

ALKALINITY TO RAS

NEW SUPPLEMENTAL ALKALINITY SYSTEM

NEW SUPPLEMENTAL METHANOL SYSTEM

EXISTING OXYGEN GENERATION FACILITY RETROFITTED FOR AERATION BLOWERS

SOUTH MEMBRANE EQUIPMENT GALLERY

SOUTH RAS PUMP STATION

**Site layout issues/constraints:**

- Significant conveyance challenges associated with PE, ML, and RAS streams (with ML at 5Q and RAS at 4Q)
- Likely requires above-grade routing of large RAS conduits to aeration basins
- Assumes PE can be pumped to new fine screening facility from existing intermediate pump station
- Likely requires above-grade routing of aeration air header from oxygen generation facility to aeration basins

**Implementation challenges or constructibility considerations:**

- Long-term bypass of secondary treatment likely required to allow MBR construction
- Difficult construction of MBR adjacent to existing below-grade channels and galleries
- Significant demolition of existing structures

**Risks:**

- Existing power supply insufficient for increased electrical loads
- Membrane permeability lower than design value limits secondary treatment capacity (conservative flux limit used for site layout to reduce this risk)
- High operational complexity
- No available space for aeration basin expansion

NOTE: SITE LAYOUT DESIGNED FOR CURRENT PLANT RATED CAPACITY.





**Site layout issues/constraints:**

- Limited available space for construction of MBR and PE fine screening facility
- Likely requires above-grade routing of large RAS conduits to aeration basins
- Assumes portion of PE can be pumped to new fine screening facility from existing intermediate pump station
- Likely requires above-grade routing of aeration air header from oxygen generation facility to aeration basins

**Implementation challenges or constructibility considerations:**

- Likely possible to sequence construction to minimize required shutdowns or bypass of secondary treatment
- Difficult construction of MBR adjacent to existing below-grade channels and galleries

**Risks:**

- Existing power supply insufficient for increased electrical loads
- Membrane permeability lower than design value limits secondary treatment capacity (conservative flux limit used for site layout to reduce this risk)
- High operational complexity
- No available space for aeration basin, MBR, or secondary clarifier expansion

NOTE: SITE LAYOUT DESIGNED FOR CURRENT PLANT RATED CAPACITY.





**Site layout issues/constraints:**

- Limited available space for construction of MBR and PE fine screening facility
- Likely requires above-grade routing of large RAS conduits to aeration basins
- Assumes portion of PE can be pumped to new fine screening facility from existing intermediate pump station
- Likely requires above-grade routing of aeration air header from oxygen generation facility to aeration basins

**Implementation challenges or constructibility considerations:**

- Likely possible to sequence construction to minimize required shutdowns or bypass of secondary treatment
- Difficult construction of MBR adjacent to existing below-grade channels and galleries

**Risks:**

- Existing power supply insufficient for increased electrical loads
- Membrane permeability lower than design value limits secondary treatment capacity (conservative flux limit used for site layout to reduce this risk)
- High operational complexity
- No available space for aeration basin, MBR, or secondary clarifier expansion

NOTE: SITE LAYOUT DESIGNED FOR CURRENT PLANT RATED CAPACITY.





**Site layout issues/constraints:**  
 -Likely requires above-grade routing of aeration air header from oxygen generation facility to aeration basins

**Implementation challenges or constructibility considerations:**  
 -Requires construction of new greenfield treatment facilities and collection system modifications to replace lost plant capacity prior to construction  
 -Likely possible to sequence construction to minimize required shutdowns or bypass of secondary treatment

**Risks:**  
 -No available space for aeration basin expansion  
 -Limited available space for secondary clarifier expansion

NOTE: SITE LAYOUT DESIGNED FOR WINTER MAX MONTH CAPACITY OF 98 MGD (117 MGD LESS THAN CURRENT PLANT RATED CAPACITY).





NEW SIDESTREAM BIOAUGMENTATION TANK

EXISTING HPO BASINS CONVERTED TO MLE-CAS

NEW AERATION BASINS

IMLR (TYP)

BAR EFFLUENT TO RAS

ALKALINITY TO RAS

CENTRATE TO SIDESTREAM BAR

METHANOL TO AERATION BASINS

AERATION AIR TO AERATION BASINS

RAS TO SIDESTREAM BAR

Site layout issues/constraints:

- Feasibility of routing RAS to/from sidestream bioaugmentation by connecting to existing piping in RAS galleries would need to be confirmed during design
- Likely requires above-grade routing of aeration air header from oxygen generation facility to aeration basins

Implementation challenges or constructibility considerations:

- Requires construction of new greenfield treatment facilities and collection system modifications to replace lost plant capacity prior to construction
- Likely possible to sequence construction to minimize required shutdowns or bypass of secondary treatment

Risks:

- No available space for aeration basin or secondary clarifier expansion

NEW SUPPLEMENTAL ALKALINITY SYSTEM

NEW SUPPLEMENTAL METHANOL SYSTEM

EXISTING OXYGEN GENERATION FACILITY RETROFITTED FOR AERATION BLOWERS

NOTE: SITE LAYOUT DESIGNED FOR WINTER MAX MONTH CAPACITY OF 105 MGD (110 MGD LESS THAN CURRENT PLANT RATED CAPACITY).

**Brown AND Caldwell**

WEST POINT TREATMENT PLANT NITROGEN REMOVAL STUDY  
SCENARIO 4: YEAR-ROUND N REMOVAL, 8-MG/L TIN EQUIVALENT (REDUCED CAPACITY)  
ALTERNATIVE 4C: MLE + SIDESTREAM BIOAUGMENTATION

SCALE:  
1" = 300'



**King County**





NEW SIDESTREAM ANAMMOX SYSTEM

EXISTING HPO BASINS CONVERTED TO 4SMB-CAS

NEW AERATION BASINS

IMLR (TYP)

CENTRATE TO ANAMMOX

ANAMMOX EFFLUENT TO PE

ALKALINITY TO RAS

METHANOL TO AERATION BASINS

AERATION AIR TO AERATION BASINS

**Site layout issues/constraints:**

-Likely requires above-grade routing of aeration air header from oxygen generation facility to aeration basins

**Implementation challenges or constructibility considerations:**

-Requires construction of new greenfield treatment facilities and collection system modifications to replace lost plant capacity prior to construction  
-Likely possible to sequence construction to minimize required shutdowns or bypass of secondary treatment

**Risks:**

-No available space for aeration basin or secondary clarifier expansion

NEW SUPPLEMENTAL ALKALINITY SYSTEM

NEW SUPPLEMENTAL METHANOL SYSTEM

EXISTING OXYGEN GENERATION FACILITY RETROFITTED FOR AERATION BLOWERS

NOTE: SITE LAYOUT DESIGNED FOR WINTER MAX MONTH CAPACITY OF 105 MGD (110 MGD LESS THAN CURRENT PLANT RATED CAPACITY).

**Brown AND Caldwell**

WEST POINT TREATMENT PLANT NITROGEN REMOVAL STUDY  
SCENARIO 4: YEAR-ROUND N REMOVAL, 8-MG/L TIN EQUIVALENT (REDUCED CAPACITY)  
ALTERNATIVE 4D: 4SMB + SIDESTREAM ANAMMOX

SCALE:  
1" = 300'



**King County**





NEW SIDESTREAM BIOAUGMENTATION TANK

EXISTING HPO BASINS CONVERTED TO 4SMB-CAS

NEW AERATION BASINS

IMLR (TYP)

BAR EFFLUENT TO RAS

ALKALINITY TO RAS

CENTRATE TO SIDESTREAM BAR

METHANOL TO AERATION BASINS

AERATION AIR TO AERATION BASINS

RAS TO SIDESTREAM BAR

Site layout issues/constraints:

- Feasibility of routing RAS to/from sidestream bioaugmentation by connecting to existing piping in RAS galleries would need to be confirmed during design
- Likely requires above-grade routing of aeration air header from oxygen generation facility to aeration basins

Implementation challenges or constructibility considerations:

- Requires construction of new greenfield treatment facilities and collection system modifications to replace lost plant capacity prior to construction
- Likely possible to sequence construction to minimize required shutdowns or bypass of secondary treatment

Risks:

- No available space for aeration basin or secondary clarifier expansion

NEW SUPPLEMENTAL ALKALINITY SYSTEM

NEW SUPPLEMENTAL METHANOL SYSTEM

EXISTING OXYGEN GENERATION FACILITY RETROFITTED FOR AERATION BLOWERS

NOTE: SITE LAYOUT DESIGNED FOR WINTER MAX MONTH CAPACITY OF 107 MGD (108 MGD LESS THAN CURRENT PLANT RATED CAPACITY).

**Brown AND Caldwell**

WEST POINT TREATMENT PLANT NITROGEN REMOVAL STUDY  
 SCENARIO 4: YEAR-ROUND N REMOVAL, 8-MG/L TIN EQUIVALENT (REDUCED CAPACITY)  
 ALTERNATIVE 4E: 4SMB + SIDESTREAM BIOAUGMENTATION

SCALE:  
1" = 300'





## **Attachment B: Greenhouse Gas Emissions Results and Literature Review of Nitrous Oxide Emission Factors**





		Annual Averages										
Alternative		1	2A	2B	2C	3A	3D	4A	4C	4D	4E	
Alternative Type		Existing mainstream + sidestream anammox	MLE/MBR	MLE/MBR + sidestream anammox	4SMB/MBR + sidestream anammox	MLE/MBR + sidestream anammox	4SMB/MBR + sidestream anammox	MLE	MLE + sidestream bioaugmentation	4SMB + sidestream anammox	4SMB + sidestream bioaugmentation	
Operational Parameters	Power Consumption (Kwh/yr)	23,303,662	103,199,744	103,233,035	99,617,157	47,212,548	46,002,561	15,081,946	16,734,955	14,670,935	17,411,012	
	Prod. Emissions (CO2e MT/yr)	207.4	918.5	918.8	886.6	420.2	409.4	134.2	148.9	130.6	155.0	
	Supplemental Chemicals											
	Sodium Hypochlorite (gal/yr)	-	383,611	383,611	383,611	84,135	84,135	-	-	-	-	
	Prod. Emissions (CO2e MT/yr)	-	1,079	1,079	1,079	237	237	-	-	-	-	
	Transportation (CO2e MT/yr)	-	11.5	11.5	11.5	2.5	2.5	-	-	-	-	
	Citric Acid (gal/yr)	-	48,320	48,320	48,320	9,855	9,855	-	-	-	-	
	Prod. Emissions (CO2e MT/yr)	-	93	93	93	19	19	-	-	-	-	
	Transportation (CO2e MT/yr)	-	1.45	1.45	1.45	0.30	0.30	-	-	-	-	
	Alkalinity (25% Caustic) (gal/yr)	-	5,475,015	5,475,015	3,832,485	4,379,985	3,649,954	2,737,470	2,865,204	2,865,280	2,901,765	
	Prod. Emissions (CO2e MT/yr)	-	14,435	14,435	10,105	11,548	9,623	7,218	7,554	7,555	7,651	
	Transportation (CO2e MT/yr)	-	164.3	164.3	115.0	131.4	109.5	82.1	86.0	86.0	87.1	
	Methanol (gal/yr)	-	2,600,838	1,932,383	2,116,712	840,913	786,071	687,185	786,213	314,223	640,004	
	Prod. Emissions (CO2e MT/yr)	-	5,221	3,879	4,249	1,688	1,578	1,379	1,578	631	1,285	
	Transportation (CO2e MT/yr)	-	78.0	58.0	63.5	25.2	23.6	20.6	23.6	9.4	19.2	
Supplemental Chemical Subtotal (CO2e MT/yr)		-	21,083	19,721	15,717	13,651	11,593	8,700	9,242	8,281	9,042	
Modeled Parameters	Influent TN Load (lb/d)	30,132	30,132	30,132	30,132	30,132	30,132	13,735	14,716	14,716	14,996	
	Secondary TN Load (Lb/d)	29,613	32,174	29,114	29,139	29,367	29,367	14,456	15,538	13,949	15,804	
	Mainstream (HPO or CAS)											
	Influent TN Load (lb/d)	29,613	-	-	-	16,726	16,726	14,456	15,538	13,949	15,804	
	Effluent TN Load (lb/d)	24,392	-	-	-	7,932	7,128	4,218	4,455	4,380	4,425	
	Mainstream (MBR)											
	Influent TN Load (lb/d)	-	32,174	29,114	29,139	12,642	12,642	-	-	-	-	
	Effluent TN Load (lb/d)	-	7,942	7,684	3,928	5,948	5,043	-	-	-	-	
	Sidestream											
	Influent TN Load (lb/d)	4,154	-	4,034	4,065	4,182	4,182	-	2,115	2,001	2,126	
Effluent TN Load (lb/d)	1,196	-	1,162	1,171	1,205	1,205	-	2,115	576	2,126		
Secondary Effluent TN Load (lb/d)	24,392	7,942	7,684	3,928	13,881	12,171	4,218	4,455	4,380	4,425		
Nitrous Oxide Emissions	N2O Emissions, Sec Treat (CO2e MT/Yr)	2,016	1,339	3,142	13,469	2,886	9,871	566	613	5,335	5,189	
	Mainstream (HPO or CAS) (CO2e MT/Yr)	-	-	-	-	486	4,376	566	613	4,363	5,189	
	Mainstream (MBR) (CO2e MT/Yr)	-	1,339	1,184	11,496	370	3,465	-	-	-	-	
	Sidestream (CO2e MT/Yr)	2,016	-	1,958	1,973	2,030	2,030	-	-	971	-	
	N2O Emissions, Effluent Nitrogen Discharge (CO2e MT/Yr)	8,426	2,744	2,654	1,357	4,795	4,205	1,457	1,539	1,513	1,529	
	Total N2O Emissions, Plant (CO2e MT/Yr)	10,442	4,083	5,797	14,826	7,681	14,076	2,023	2,152	6,848	6,717	
GHG Emission	Nitrous oxide	10,442	4,083	5,797	14,826	7,681	14,076	2,023	2,152	6,848	6,717	
	Energy	207	918	919	887	420	409	134	149	131	155	
	Chemicals	-	21,083	19,721	15,717	13,651	11,593	8,700	9,242	8,281	9,042	
	<b>Total (CO2e MT/Yr)</b>	<b>10,649</b>	<b>26,085</b>	<b>26,437</b>	<b>31,429</b>	<b>21,753</b>	<b>26,078</b>	<b>10,857</b>	<b>11,543</b>	<b>15,259</b>	<b>15,914</b>	

GHG Emission Factor	Value	Unit	Note	Source/Reference
Methane	28	gCO2e/gCH4		IPCC (2014). Climate Change 2014 Synthesis Report Fifth Assessment Report
Nitrous Oxide	265	gCO2e/gN2O		IPCC (2014). Climate Change 2014 Synthesis Report Fifth Assessment Report
Sodium Hydroxide (Caustic Soda), 25%	0.505	kg CO2e/kg	Production emissions	EPA, 2016. LCI data - Treatment Chemicals, Construction Materials, Transportation, onsite equipment and othe processes for use in SEFA; Ecoinvent v2.2
Sodium Hydroxide (Caustic Soda), 25%	0.545	kg CO2e/kg	Production emissions, Chlor-alkali, membrane cell technique	EPA, 2016. LCI data - Treatment Chemicals, Construction Materials, Transportation, onsite equipment and othe processes for use in SEFA; Ecoinvent v2.2
Methanol, 100%	1.4	kg CO2e/kg	Production emissions	SimaProv7.10, BLE, 2010, Guideline Sustainable Biomass Production
Methanol, 100%	0.67	MT CO2e/MT feedstock	Production Emissions, Steam reforming of natural gas, Table 3.12	2006. IPCC Guidelines for National Greenhouse Gas Inventories, Chapter 3 Chemical Industry Emissions
Citric Acid, Anhydrous	0.429	kg CO2e/kg citric acid	Production emissions	<a href="https://www.canada.ca/en/environment-climate-change/services/climate-change/pricing-pollution-how-it-will-work/output-based-pricing-system/complete-text-for-proposal-regulations.html">https://www.canada.ca/en/environment-climate-change/services/climate-change/pricing-pollution-how-it-will-work/output-based-pricing-system/complete-text-for-proposal-regulations.html</a>
Citric Acid, Anhydrous	0.96	kg Co2e/kg	Production emissions	ISCC 2015 GHG emissions; Biograce v 4d, 2014
Citric Acid, 50%	0.41	kg Co2e/kg	Production emissions, Microbial	Nica, Anca & Woinaroschy, Alexandru. (2010). Environmental assessment of citric acid production. UPB Scientific Bulletin, Series B: Chemistry and Materials Science. 72.
Sodium Hypochlorite (12.5%)	0.636		Production emissions	He, C., Liu, Z. & Hodgins, M., 2013.

King County Electricity Profile	MT/MWh	g CO2e/kWh	MT/MMBtu	\$/KW
West Point	0.0089	8.90	0.003	0.0781
South Plant	0.0000	0.00	0.132	0.0758
Brightwater	0.0065	6.50	0.002	0.0781

Other Assumptions	Value	Units	Notes	Source/Reference
Sodium Hydroxide (25%) Specific Gravity	1.278			MSDS
Methanol Specific Gravity	0.7915			MSDS
Citric Acid Specific Gravity	1.24			Suez Proposal, 2019
Sodium Hypochlorite (12.5%) Specific Gravity	1.168			Suez Proposal, 2019
<b>Trucking and Transportation</b>				
Liquid transportation Capacity	6,800	Gallons		Assumption
Class 8 Tanker Truck	2.04	kg CO2e/ mile		USEPA, (2004)
Methanol Transportation, Roundtrip	100	miles		Assumption
Citric Acid Transportation, Roundtrip	100	miles		Assumption
Sodium Hydroxide Transportation, Roundtrip	100	miles		Assumption
Sodium Hypochlorite Transportation, Roundtrip	100	miles		Assumption

Configuration	N2O Emission Factors	% inf TKN emitted as N2O	% inf TN emitted as N2O	% TN Removed Emitted as N2O	IPCC Emission Factor Table 6A.5	
					Emission Factor Used % inf TN emitted as N2O	Emission Factor Used % TN Removed Emitted as N2O
BNR (IPCC, 2014)	7.0 <sup>3</sup> (Treatment), 0.005 <sup>d</sup>		0.764, 1.44, 1.3 <sup>7</sup> , 0.28 - 11.84 <sup>8</sup>			
BNR	-	-	0-14.6 <sup>6</sup>	-	1.6	1.6
Four-Stage Bardenpho (4SMB)	33±16 <sup>1,a</sup> , 92±47 <sup>1,a</sup>	0.60±0.29 <sup>1</sup> , 1.6±0.83 <sup>1</sup>	0.66±0.32 <sup>1</sup> , 2.9±0.15 <sup>1</sup> , 0.36 <sup>1</sup>	0.66±0.32 <sup>1</sup> , 2.9±1.5 <sup>1</sup>	0.36	0.66
MLE	6.8±3.5 <sup>1,a</sup> , 5.4±2.0 <sup>1,a</sup>	0.44 <sup>9</sup> , 0.07 <sup>9</sup>	0.07±0.04 <sup>1</sup> , 0.06±0.02 <sup>1</sup> , 0.008 <sup>2</sup> , 0.001 <sup>2</sup>	0.09±0.05 <sup>1</sup> , 0.07±0.03 <sup>1</sup>	0.07, 0.06	0.08
MBR	No Clear Literature			-	-	Assumed upstream treatment EF
Sidestream Anammox	-	-	0.75 <sup>3</sup> , 1.7 <sup>4</sup> , 0.9-1.3 <sup>5</sup> , 2-9 <sup>6</sup> , 0.51 <sup>10</sup>	-	-	0.0099
Sidestream Bioaugmentation	No Clear Literature			-	-	-

**Reference Notation**

1	Ahn et al., 2009
2	Tumendelger et al., 2019
3	Christensson et al., 2013
4	Weissenbacher et al., 2012
5	Stenstrom et al., 2017
6	Wicht et Beier, 1995
7	Weissenbacher et al., 2010
8	Foley et al., 2010
9	Chandran, 2011
10	Baresel et al., 2016

**Reference Notation**

a
b
c
d

**Units**

(g N2O/PE/Yr)
(g N2O/g reduced N)
(g N2O/g inf N)
(g N2O-N/g eff N)

## References

- Ahn, J. H., Kim, S., Park, H., Rahm, B., Pagilla, K., & Chandran, K. (2010). N<sub>2</sub>O emissions from activated sludge processes, 2008-2009: Results of a national monitoring survey in the united states. *Environmental Science and Technology*, 44(12), 4505–4511. <https://doi.org/10.1021/es903845y>
- Baresel, C., Andersson, S., Yang, J., & Andersen, M. H. (2016). Comparison of nitrous oxide (N<sub>2</sub>O) emissions calculations at a Swedish wastewater treatment plant based on water concentrations versus off-gas concentrations. *Advances in Climate Change Research*, 7(3), 185–191. <https://doi.org/10.1016/j.accre.2016.09.001>
- Chandran, K. (2011). *Protocol for the measurement of nitrous oxide fluxes from biological wastewater treatment plants*. *Methods in Enzymology* (1st ed., Vol. 486). Elsevier Inc. <https://doi.org/10.1016/B978-0-12-381294-0.00016-X>
- Christensson, M., Ekström, S., Andersson Chan, A. Le Vaillant, E., and Lemaire, R. (2013) “Experience from startups of the first ANITA Mox plants,” *Water Sci. Technol.*, 67, 12, 2677- 2684
- Foley, J., de Haas, D., Yuan, Z., & Lant, P. (2010). Nitrous oxide generation in full-scale biological nutrient removal wastewater treatment plants. *Water Research*, 44(3), 831–844. <https://doi.org/10.1016/j.watres.2009.10.033>
- Stenström, F. (2017). *Risk of nitrous oxide emissions and potential of bioaugmentation when treating digester supernatant via nitrification-denitrification*.
- Tumendelger, A., Alshboul, Z., & Lorke, A. (2019). Methane and nitrous oxide emission from different treatment units of municipal wastewater treatment plants in Southwest Germany. *PLoS ONE*, 14(1), e0209763. <https://doi.org/10.1371/journal.pone.0209763>
- Weissenbacher, N., Takacs, I., Murthy, S., Fuerhacker, M., & Wett, B. (2010). Gaseous Nitrogen and Carbon Emissions from a Full-Scale Deammonification Plant. *Water Environment Research*, 82(2), 169–175. <https://doi.org/10.2175/106143009x447867>
- Wicht, H. (1996). A model for predicting nitrous oxide production during denitrification in activated sludge. In *Water Science and Technology* (Vol. 34, pp. 99–106). Pergamon Press Inc. [https://doi.org/10.1016/0273-1223\(96\)00634-8](https://doi.org/10.1016/0273-1223(96)00634-8)

## **Attachment C: Basis of Capital Cost Estimates of Alternatives**

---



**West Point Treatment Plant Nitrogen Removal Alternatives Cost Estimate Summary - ACEI Class 5**

Alternative	1	2A	2B	2C	3A	3D	4A	4C	4D	4E
<b>Scenario modifications or effluent limits/targets</b>	Sidestream treatment only	Year-round N removal, lowest effluent TIN possible while maintaining existing secondary treatment capacity			Seasonal N removal, lowest effluent TIN possible while maintaining existing secondary treatment capacity		Year-round N removal, effluent TIN limit of 8 mg/L (identify reduced secondary treatment capacity)			
<b>Alternative Description</b>	Existing mainstream + sidestream anammox	MLE/MBR	MLE/MBR + sidestream anammox	4SMB/MBR + sidestream anammox	MLE/MBR + sidestream anammox	4SMB/MBR + sidestream anammox	MLE	MLE + sidestream bioaugmentation	4SMB + sidestream anammox	4SMB + sidestream bioaugmentation
<b>DIRECT: SUBTOTAL CONSTRUCTION COSTS</b>										
<b>Item No.</b>	<b>Item Description</b>	<b>Item Cost</b>								
1	A - Primary Effluent (PE)		\$ 25,958,000	\$ 25,958,000	\$ 25,958,000	\$ 12,600,000	\$ 12,600,000			
2	B - Aeration Basins		\$ 48,319,000	\$ 48,319,000	\$ 51,186,000	\$ 48,319,000	\$ 51,186,000	\$ 48,319,000	\$ 48,319,000	\$ 51,186,000
3	C - Membrane Basins		\$ 547,878,000	\$ 547,878,000	\$ 547,878,000	\$ 170,430,000	\$ 170,430,000			
4	D - Internal Mixed Liquor Return (IMLR) Pumping		\$ 40,757,000	\$ 40,757,000	\$ 39,884,000	\$ 40,757,000	\$ 40,699,000	\$ 30,572,000	\$ 30,572,000	\$ 29,885,000
5	E - Return Activated (RAS) Pumping		\$ 9,706,000	\$ 9,706,000	\$ 9,706,000	\$ 2,710,000	\$ 2,710,000	\$ 271,000	\$ 271,000	\$ 271,000
6	F - Sidestream Anammox	\$ 28,353,000		\$ 28,353,000	\$ 28,353,000	\$ 28,353,000	\$ 28,353,000			\$ 17,828,000
7	G - Supplemental Methanol System		\$ 7,036,000	\$ 5,277,000	\$ 5,345,000	\$ 3,518,000	\$ 3,586,000	\$ 1,759,000	\$ 1,759,000	\$ 1,827,000
8	H - Supplemental Alkalinity System		\$ 4,059,000	\$ 4,059,000	\$ 3,383,000	\$ 2,706,000	\$ 2,706,000	\$ 2,706,000	\$ 2,706,000	\$ 3,383,000
9	I - Aeration Blowers		\$ 54,139,000	\$ 48,907,000	\$ 35,267,000	\$ 36,707,000	\$ 33,734,000	\$ 31,665,000	\$ 34,994,000	\$ 32,115,000
10	J - Aeration Basin Mixers for Anoxic Zones		\$ 3,102,000	\$ 3,102,000	\$ 5,614,000	\$ 2,596,000	\$ 4,323,000	\$ 2,456,000	\$ 4,035,000	\$ 4,035,000
11	K - Sidestream Bioaugmentation							\$ 7,647,000		\$ 7,647,000
16	P - Miscellaneous Scope	\$ 330,000	\$ 255,261,000	\$ 254,772,000	\$ 254,346,000	\$ 243,783,000	\$ 243,546,000	\$ 236,794,000	\$ 238,906,000	\$ 236,976,000
	<b>Subtotal Construction Costs</b>	\$ 28,683,000	\$ 996,215,000	\$ 1,017,088,000	\$ 1,006,920,000	\$ 592,479,000	\$ 593,873,000	\$ 354,542,000	\$ 367,630,000	\$ 377,506,000
	Allowance for Indeterminates (Design Allowance)	\$ 7,170,750	\$ 249,053,750	\$ 254,272,000	\$ 251,730,000	\$ 148,119,750	\$ 148,468,250	\$ 88,635,500	\$ 91,907,500	\$ 94,376,500
	Street Use Permit	\$ -	\$ -	\$ -	\$ -	\$ -	\$ -	\$ -	\$ -	\$ -
	<b>ESTIMATED PROBABLE COST OF CONSTRUCTION BID</b>	\$ 35,853,750	\$ 1,245,268,750	\$ 1,271,360,000	\$ 1,258,650,000	\$ 740,598,750	\$ 742,341,250	\$ 443,177,500	\$ 459,537,500	\$ 471,882,500
<b>DIRECT: SUBTOTAL ADDITIONAL CONSTRUCTION COSTS</b>										
	Mitigation Construction Contracts	\$ -	\$ -	\$ -	\$ -	\$ -	\$ -	\$ -	\$ -	\$ -
	Construction Change Order Allowance	\$ 3,585,375	\$ 124,526,875	\$ 127,136,000	\$ 125,865,000	\$ 74,059,875	\$ 74,234,125	\$ 44,317,750	\$ 45,953,750	\$ 47,188,250
	Material Pricing Uncertainty Allowance	\$ -	\$ -	\$ -	\$ -	\$ -	\$ -	\$ -	\$ -	\$ -
	<b>Subtotal Primary Construction Amount</b>	\$ 39,439,125	\$ 1,369,795,625	\$ 1,398,496,000	\$ 1,384,515,000	\$ 814,658,625	\$ 816,575,375	\$ 487,495,250	\$ 505,491,250	\$ 519,070,750
	Construction Sales Tax	\$ 3,983,352	\$ 138,349,358	\$ 141,248,096	\$ 139,836,015	\$ 82,280,521	\$ 82,474,113	\$ 49,237,020	\$ 51,054,616	\$ 52,426,146
	Owner Furnished Equipment	\$ -	\$ -	\$ -	\$ -	\$ -	\$ -	\$ -	\$ -	\$ -
	Outside Agency Construction	\$ -	\$ -	\$ -	\$ -	\$ -	\$ -	\$ -	\$ -	\$ -
	<b>Subtotal KC Contribution to Construction</b>	\$ 43,422,477	\$ 1,508,144,983	\$ 1,539,744,096	\$ 1,524,351,015	\$ 896,939,146	\$ 899,049,488	\$ 536,732,270	\$ 556,545,866	\$ 571,496,896
<b>DIRECT: SUBTOTAL OTHER CAPITAL CHARGES</b>										
	KC/WTD Direct Implementation	\$ -	\$ -	\$ -	\$ -	\$ -	\$ -	\$ -	\$ -	\$ -
	Misc. Capital Costs	\$ 78,878	\$ 2,739,591	\$ 2,796,992	\$ 2,769,030	\$ 1,629,317	\$ 1,633,151	\$ 974,991	\$ 1,010,983	\$ 1,038,142
	<b>TOTAL DIRECT CONSTRUCTION COSTS</b>	\$ 43,501,000	\$ 1,510,885,000	\$ 1,542,541,000	\$ 1,527,120,000	\$ 898,568,000	\$ 900,683,000	\$ 537,707,000	\$ 557,557,000	\$ 572,535,000
<b>INDIRECT: NON-CONSTRUCTION COSTS</b>										
	Design and Construction Consulting	\$ 15,222,806	\$ 343,148,446	\$ 349,077,639	\$ 346,191,969	\$ 223,395,717	\$ 223,829,678	\$ 119,910,202	\$ 123,536,230	\$ 126,257,222
	Other Consulting Services	\$ -	\$ -	\$ -	\$ -	\$ -	\$ -	\$ -	\$ -	\$ -
	Permitting & Other Agency Support	\$ 347,064	\$ 20,546,934	\$ 20,977,440	\$ 20,767,725	\$ 12,219,879	\$ 12,248,631	\$ 7,312,429	\$ 7,582,369	\$ 7,786,061
	Right-of-Way	\$ -	\$ -	\$ -	\$ -	\$ -	\$ -	\$ -	\$ -	\$ -
	Misc. Service & Materials	\$ 709,904	\$ 24,656,321	\$ 25,172,928	\$ 24,921,270	\$ 14,663,855	\$ 14,698,357	\$ 8,774,915	\$ 9,098,843	\$ 9,343,274
	Non-WTD Support	\$ 256,354	\$ 8,903,672	\$ 9,090,224	\$ 8,999,348	\$ 5,295,281	\$ 5,307,740	\$ 3,168,719	\$ 3,285,693	\$ 3,373,960
	WTD Staff Labor	\$ 7,439,167	\$ 246,834,669	\$ 251,659,621	\$ 249,309,905	\$ 139,880,484	\$ 140,187,568	\$ 85,362,856	\$ 88,287,813	\$ 90,490,858
	<b>Subtotal Non-Construction Costs</b>	\$ 23,975,296	\$ 644,090,042	\$ 655,977,851	\$ 650,190,217	\$ 395,455,217	\$ 396,271,974	\$ 224,529,121	\$ 231,790,947	\$ 237,251,375
	Project Contingency	\$ 20,372,487	\$ 650,609,316	\$ 663,755,737	\$ 657,352,648	\$ 390,679,738	\$ 391,564,613	\$ 230,126,929	\$ 238,312,100	\$ 244,482,695
	Initiatives	\$ 757,897	\$ 25,054,737	\$ 25,569,243	\$ 25,318,630	\$ 14,981,376	\$ 15,015,885	\$ 8,886,186	\$ 9,207,548	\$ 9,449,917
	<b>TOTAL INDIRECT NON-CONSTRUCTION COSTS</b>	\$ 45,106,000	\$ 1,319,754,000	\$ 1,345,303,000	\$ 1,332,861,000	\$ 801,116,000	\$ 802,852,000	\$ 463,542,000	\$ 479,311,000	\$ 491,184,000
	<b>TOTAL PROJECT COST</b>	\$ 88,610,000	\$ 2,830,640,000	\$ 2,887,840,000	\$ 2,859,980,000	\$ 1,699,690,000	\$ 1,703,540,000	\$ 1,001,250,000	\$ 1,036,870,000	\$ 1,063,720,000
	<b>TOTAL PROJECT COST - Low End (-50%)</b>	\$ 44,310,000	\$ 1,415,320,000	\$ 1,443,920,000	\$ 1,429,990,000	\$ 849,850,000	\$ 851,770,000	\$ 500,630,000	\$ 518,440,000	\$ 531,860,000
	<b>TOTAL PROJECT COST - High End (+300%)</b>	\$ 354,440,000	\$ 11,322,560,000	\$ 11,551,360,000	\$ 11,439,920,000	\$ 6,798,760,000	\$ 6,814,160,000	\$ 4,005,000,000	\$ 4,147,480,000	\$ 4,224,000,000



# King County

Department of Natural Resources and Parks  
Wastewater Treatment Division

## Project Planning and Delivery Section

### BASIS OF ESTIMATE

---

Project Name	<b>West Point Treatment Plant Nitrogen Removal - Alternative 1</b>
Project Number	
Date Prepared	March 05, 2020
Requested by	Tiffany Knapp, King County WTD
Prepared by	Douglas W. Leo, CCP, CEP, FRICS, FAACE Hon. Life, (VMS, Inc.)
Estimate Classification	WTD Class 5
Estimate Purpose	King County Class 5 Concept Screening
Estimate ID (Version)	7
Project Manager	Eron Jacobson, King County WTD
Project Control Engineer	
Cc or Distribution List	

*Note that the accuracy of the associated cost estimate is dependent upon the various underlying assumptions, inclusions, and exclusions described herein. Actual project costs may differ and can be significantly affected by factors such as changes in the external environment, the manner in which the project is executed and controlled, and other factors that may impact the estimate basis or otherwise affect the project. Estimate accuracy ranges are only assessments based upon the cost estimating methods and data employed in preparing the estimate and are not a guarantee of actual project costs.*

## BASIS OF ESTIMATE

Project Name	<b>West Point Treatment Plant Nitrogen Removal - Alternative 1</b>		
Project Number:		Date:	March 05, 2020

### 1.0 Purpose

---

The purpose of this estimate is to provide cost information to support King County's West Point Treatment Plant (WPTP) Flows and Loading Alternative Evaluation for the Nitrogen Removal Project. A series of alternatives have been developed for project evaluation to determine the best engineering and project cost solution.

This estimate was prepared to establish a King County Wastewater Treatment Division (WTD) pre-Class 5 conceptual cost estimate to provide order of magnitude cost to support WTD's capital project identification and budgeting process for Total Project Costs. The WTD pre-Class 5 estimate provides similar documentation to that of an AACE International Class 5 estimate. The range of anticipated project costs, per WTD estimating guidance, is -50% / +300%. The range of uncertainty is beyond that for a typical Class 5 estimate due to the scope being proximally defined with today's relative solutions and technologies to resolving the identified needs; when the projects move forward into capital delivery over the longer term, it is anticipated that many differences and changes may arise as the known and defined engineering solutions are developed.

Douglas Leo of Value Management Strategies, Inc. (VMS) prepared this Basis of Estimate in coordination with King County WTD, the Brown and Caldwell Engineers team, and the VMS estimating team after receiving scope information from WTD in October 2019 through March 2020. This Basis of Estimate reflects VMS's best understanding of the estimating process for this project, as explained by King County WTD and Brown and Caldwell.

### 2.0 Project Scope Definition

---

This estimate includes all investigation, administration/owners' costs, engineering and design, purchases, fabrications, installations, process certifications, permitting, community impacts, and miscellaneous costs not specifically excluded elsewhere in this document.

Comprehensive Total Field Costs are generated from historical allowances, sources such as WTD estimating tools, historical costs, and RS Means/VMS estimating databases. All supporting indirect costs were generated from the WTD PRISM historical database. All costs included in the estimate reflect the best understanding of requirements as they existed at the time this estimate was prepared.

The scope of Alternative 1 is to provide upgrades and retrofits to the existing mainstream and Sidestream Anammox. The scope was developed to a Conceptual Design level adequate to assess operations and maintenance issues, energy impacts, permitting and code compliance issues, constructability, and estimated costs.

The Project Estimate was prepared utilizing the following Work Breakdown Structure (WBS) in order to provide clarity and transparency to the estimated costs. The scope as identified for the alternative is described below in accordance with the WBS. Details are based on the known and defined scope in the design documents provided. See section 3.0 for a detailed list of Design Documents.

- A. Primary Effluent (PE)
  - *Not included in the scope for this alternative.*
- B. Aeration Basins
  - *Not included in the scope for this alternative.*
- C. Membrane Basins
  - *Not included in the scope for this alternative.*



## BASIS OF ESTIMATE

Project Name	<b>West Point Treatment Plant Nitrogen Removal - Alternative 1</b>		
Project Number:		Date:	March 05, 2020

- D. Internal Mixed Liquor Return (IMLR) Pumping
  - *Not included in the scope for this alternative.*
- E. Return Activated Sludge (RAS) Pump
  - *Not included in the scope for this alternative.*
- F. Sidestream Anammox
  - Sidestream Anammox – purchase and install
  - Pumps / Skimmer / Chains / Flight for Sedimentation Tank / Mixers – purchase and install
  - Centrate EQ Tank (80,000-gal) – purchase and install
  - Centrate Sedimentation Tank (151,000-gal) – purchase and install
  - Anammox Reactor Tanks (375,000-gal) – purchase and install
  - Contractor Permit Fees at 1.0% Direct Costs
- G. Supplemental Methanol System
  - *Not included in the scope for this alternative.*
- H. Supplemental Alkalinity System
  - *Not included in the scope for this alternative.*
- I. Aeration Blowers
  - *Not included in the scope for this alternative.*
- J. Aeration Basin Mixers for Anoxic Zones
  - *Not included in the scope for this alternative.*
- K. Sidestream Bioaugmentation
  - *Not included in the scope for this alternative.*
- L. Tertiary Pumps
  - *Not included in the scope for this alternative.*
- M. Tertiary Fixed Film System
  - *Not included in the scope for this alternative.*
- N. Aeration / MBR Odor Control
  - *Not included in the scope for this alternative.*
- O. Primary Clarifier / Aerated Grit Tank
  - *Not included in the scope for this alternative.*
- P. Miscellaneous Scope
  - PE Pipe
  - Centrate to Anammox
  - Contractor Permit Fees

### 3.0 Design Basis

---

This is an AACE International Class 5 estimate with all required documentation. The estimate is based on engineering deliverables, scoping documentation, discussions with the project team, and all supporting information and documentation provided in October 2019 through March 2020.

Engineering conceptual scope was provided in the following estimating deliverables. These are the most complete scoping documents that were available to the estimating provider.

Engineering and Estimating Deliverables provided include:

## BASIS OF ESTIMATE

Project Name	<b>West Point Treatment Plant Nitrogen Removal - Alternative 1</b>		
Project Number:		Date:	March 05, 2020

- West Point Treatment Process, King County WTD
- Scope Questions to Brown Caldwell – answered 10.17.19
- Brown & Caldwell Markup, Existing HPO Aerator Demo
- WPTP Nitrogen Removal Study, Layout Flow Paths, Brown and Caldwell, All Alternatives
- WPTP Nitrogen Removal Study, All Layouts, Brown and Caldwell, All Alternatives
- Anammox Equipment, Budgetary Price, Brown and Caldwell, All Alternatives
- BW Reference Drawings, Brown & Caldwell, dated: 10.20.2006
- WPTP, Cost Estimating Assumptions, Brown & Caldwell, version 0
- Aeration Basin Mechanical Drawings Package, King County WTD, dated: 1991
- Aeration Basin Structural Drawings, King County WTD, dated: 1991
- WPTP, Drawing Location Numbers, King County WTD, dated: 04.26.2018
- WPTP, Facility Plan, King County WTD, dated: 07.2017
- WPTP, Oxygen Generation Bldg. Drawings, King County WTD, dated: 1992
- WPTP, Perspective Overview, King County WTD, dated: 02.24.2017
- WPTP, Secondary Clarifiers Drawings, King County WTD, dated: 1991
- WPTP, Yard Piping Drawings (1,2,3), King County WTD, dated: 1996

### Equipment Quotes:

- Aeration Blowers, Equipment Quotation, Next Turbo, dated: 09.27.19
- MBR, Equipment Quotation, Suez, dated: 10.01.19
- PE Screens, Equipment Quotation, Huber Technology, dated: 10.02.19
- Sidestream Anammox, Equipment Quotation, Ovivo, dated: 09.06.19

## 4.0 Planning Basis

---

The following planning basis assumptions were made for the project estimate:

- No project construction plan is in place at this time.
- The assumed execution strategy is a standard workweek with limited overtime.
- No unusual site conditions have been considered as part of this estimate.
- Adequate available power exists at the site.

## 5.0 Cost Basis

---

- All allied and indirect project costs (allowances for indeterminates, change order allowance, engineering, permitting, WTD staffing, etc.) have been estimated using WTD's PRISM cost model which is baselined to historical project costs.
- The estimate was performed based on drawings, sketches, and project information provided by King County and Brown and Caldwell Engineers.
- WTD is using a PRISM cost model dated January 26, 2017. All Allied and indirect project costs have been estimated using the new WTD PRISM cost model baselined to historical project costs.
- Additional technical project complexity factors for WTD indirect project costs have been introduced and incorporated into project allied costs to allow for development of an additional WTD indirect cost allowance, based upon the unique characteristics of the project.

## BASIS OF ESTIMATE

Project Name	<b>West Point Treatment Plant Nitrogen Removal - Alternative 1</b>		
Project Number:		Date:	March 05, 2020

- Equipment factors were developed utilizing historical data which accounts for specific install of the identified equipment within a normal battery limit. Specific scope relative to this project was used in the equipment factor determination. Factors for each specific type of equipment reflect the different complexity of the installation. Engineering supplied equipment costs were multiplied by the factors in order to estimate direct construction cost for the purchase and install of the equipment.
- Estimated costs incorporate prevailing King County wage rates.
- All costs were estimated in 1<sup>st</sup> quarter 2020 dollars.

### 6.0 Allowances

---

The level and types of allowances used in the estimate is as follows (common percentages for each alternative are shown and any estimate-specific differences are indicated):

- Sales Tax was included as 10.1% applied to the base construction cost, including the design and change order contingencies.
- A 25% Allowance for Indeterminates (AFI) is applied to the base construction cost. The AFI is an allowance that accounts for the cost of known but undefined requirements necessary for a complete and workable project. The AFI accounts for elements that are not explicitly shown in the project documents to be further defined as part of the design development and project delivery process. The AFI is carried at 25% at conceptual design, based on the WTD project delivery process.
- Allowance of 10% for potential construction change orders.
- Allowance of 0.2% of the primary construction amount for miscellaneous direct capital costs.
- Allowance of 1.5% of the primary construction amount for permitting and other agency support.
- Allowance of 1.8% of the primary construction amount for miscellaneous services and material.
- Allowance of 0.65% of the primary construction amount for Non-WTD Support.
- Allowance of 1.0% of the primary construction amount for art initiatives.
- Allowance of 0.5% of the total project cost for sustainability.
- Allowance of 24.07
- % of the primary construction amount for Engineering Design Services.
- Allowance of 14.52% of the primary construction amount for Construction Management Services.
- Allowance of 17.10% of the primary construction amount for WTD Staff.
- Allowance for application of total project contingency (see *Contingency* section below).
- Allowance of 0% was included for Escalation as the estimate is produced in current year (2020) dollars.
- Allowance of 1% of Directs Costs was included for Contractor Permit Fees.
- Additional estimating allowances for WTD indirect costs of approximately \$7.08 million have been included in the Total Project Cost estimate by using a moderate degree of complexity rating for Design Engineering, Permitting and License, and Project Management, and a high degree of

## BASIS OF ESTIMATE

Project Name	<b>West Point Treatment Plant Nitrogen Removal - Alternative 1</b>		
Project Number:		Date:	March 05, 2020

complexity rating for Construction Management, and Operations Support. All other indirect costs were considered routine. Complexity factors were calibrated based on comments received from King County on March 4, 2020.

- An allowance of \$5.42 million for Design and Construction Consulting
- An allowance of \$0.15 million for Permitting & Other Agency Support
- An allowance of \$1.50 million for WTD Staff Labor

### 7.0 Assumptions

---

Any other assumptions made by the estimator but not documented elsewhere in the estimate basis are included in this section.

- All costs included in the estimate reflect the best understanding of requirements as they existed at the time the estimates were prepared. Any modifications to the present scope and/or location of the project site may have substantial cost and schedule impacts.
- The engineering design will be performed by an external consultant engineer.
- Construction management will not be performed “in-house” by WTD. It will be performed by an external consultant construction manager.
- The project will generally align with the WTD PRISM cost model for Treatment projects.
- All work will always be performed utilizing safe work methods.
- Work will be sequenced to minimize standard process, service and community interruptions. However, no costs are included to address sequencing necessary keep the plant operational during construction.
- No costs are included for any new facilities that would be required, beyond the scope of this project to replace any lost capacity to the WPTP.
- It is assumed that the best improvement solution is included in the project scope(s).
- There will be some degree of productivity loss due to the site location. Some degree of productivity loss is included in the estimated costs. Any unusual site conditions are not accounted for in this estimate.
- Any additional work discovered during project implementation would need to be either a supplemental approval of added scope or be approved as an additional project.
- This project will be engineered to meet Washington State area seismic requirements.
- A degree of minimal cost rounding will occur during the normal estimating process.
- No allowance is included for Material Pricing Uncertainty.
- Power is readily available in the general area of this project. No new power sources are included in the scope of this project.
- It is assumed that some general material contamination is present. The estimate covers minimal cost of removal wherever the contamination is disturbed during construction. This cost is covered in productivity rates utilized in the estimate.

## **BASIS OF ESTIMATE**

Project Name	<b>West Point Treatment Plant Nitrogen Removal - Alternative 1</b>		
Project Number:		Date:	March 05, 2020

### **8.0 Exclusions**

---

All potential items of cost which might be associated with the project but for which no costs have been included are listed below:

- No asbestos removal costs are included.
- No estimated costs are included for any potential delays due to interferences.
- No costs are included for utility relocations.
- No costs are included for temporary construction easements.
- No costs are included for street use or street improvement permits.
- No costs are included for additional scope beyond that as detailed in the current scope of work.

### **9.0 Exceptions**

---

This estimate is classified as a King County Wastewater Treatment Division Class 5 estimate based on an AACE International Class 5 estimate, with no exceptions per the King County WTD project process, for the scope as known at the time of the estimate preparation.

### **10.0 Risks (Threats and Opportunities)**

---

At the time of estimate preparation, a formal risk analysis session had not been conducted. General potential risks are listed below.

- There is a risk that additional scope, technology advances or major deviation from the suggested project scope will adversely impact cost and schedule.
- Future unknown or changing site conditions present a risk around productivities, schedule, and costs.
- More stringent or completely new regulations, usage fees, permitting, or environmental impacts may result in risks that could adversely impact cost and schedule.
- Potential complex construction and constructability issues could arise during construction, resulting in major design/construction changes.
- The space constraints could significantly impact assumed productivities and crew sizes identified for the estimated concept, resulting in increased costs due to loss of production.
- The scheduled timing of project execution will greatly impact the bottom-line costs. There is risk related to labor availability and fluctuating commodity and equipment pricing in the timeframe between this early conceptual estimate and the actual execution of the project. Rising costs due to inflation, escalation and competing major worldwide projects pose the possibility of noticeable project cost and schedule increases.
- Weather conditions and emergency service interruptions present the possibility of negative schedule and cost impacts.
- Any possible coordination with other agencies could result in potential impacts on costs, schedule and Project Definition process.

## **BASIS OF ESTIMATE**

Project Name	<b>West Point Treatment Plant Nitrogen Removal - Alternative 1</b>		
Project Number:		Date:	March 05, 2020

- There is a risk that stakeholders could oppose the proposed design or prefer a different approach or site to be selected, resulting in schedule delays and a higher cost alternative.

### **11.0 Contingency**

---

Contingency is a cost element of the estimate used to cover uncertainties and unforeseeable elements of cost within the defined project scope. Contingency covers inadequacies in project scope definition, estimating methods, and estimating data. Contingency specifically excludes changes in project scope, and unforeseen major events such as earthquakes, prolonged labor strikes, etc.

A 30% Project Contingency was added to the base estimate of Total Project Costs (direct and indirect) as a result of the project estimating process and in accordance with the King County WTD project delivery process.

The estimating analysis resulted in a project contingency of approximately \$20.04 million (US\$).

The total project cost at a 50% confidence level (P50) is typically used for funding and baselining of a project at this stage and level of engineering and project development. The P50 confidence level suggests that there is a 50% cumulative probability of project cost under-run (or 50% probability of exceedance) at this dollar amount for the presently defined and known project scope.

### **12.0 Management Reserve**

---

No allocation of costs was included in this estimate for Management Reserves.

Contingency is not intended to cover the costs for changes in project scope. If the project needs to provide an allowance for anticipated changes in scope or to cover the costs for items that may be required but have not yet been specifically identified as being included in the current project scope, then that amount of cost should be identified here.

### **13.0 Reconciliation**

---

Reconciliation was not conducted at this time.

### **14.0 Benchmarking**

---

All included Allied Costs as supplied by the PRISM historical database have been benchmarked against a similar portfolio of recently completed projects.

### **15.0 Estimate Quality Assurance Plan**

---

No reviews of total project costs have been conducted outside the reviews conducted within Brown and Caldwell and VMS estimating team. It is anticipated that upon completion of this estimate, reviews will happen between the estimate provider and WTD.



## BASIS OF ESTIMATE

Project Name	<b>West Point Treatment Plant Nitrogen Removal - Alternative 1</b>		
Project Number:		Date:	March 05, 2020

### 16.0 Attachments

---

#### Attachment: Estimate Deliverables

Engineering and Estimating Deliverables provided include:

- West Point Treatment Process, King County WTD
- Scope Questions to Brown Caldwell – answered 10.17.19
- Brown & Caldwell Markup, Existing HPO Aerator Demo
- WPTP Nitrogen Removal Study, Layout Flow Paths, Brown and Caldwell, All Alternatives
- WPTP Nitrogen Removal Study, All Layouts, Brown and Caldwell, All Alternatives
- Anammox Equipment, Budgetary Price, Brown and Caldwell, All Alternatives
- BW Reference Drawings, Brown & Caldwell, dated: 10.20.2006
- WPTP, Cost Estimating Assumptions, Brown & Caldwell, version 0
- Aeration Basin Mechanical Drawings Package, King County WTD, dated: 1991
- Aeration Basin Structural Drawings, King County WTD, dated: 1991
- WPTP, Drawing Location Numbers, King County WTD, dated: 04.26.2018
- WPTP, Facility Plan, King County WTD, dated: 07.2017
- WPTP, Oxygen Generation Bldg. Drawings, King County WTD, dated: 1992
- WPTP, Perspective Overview, King County WTD, dated: 02.24.2017
- WPTP, Secondary Clarifiers Drawings, King County WTD, dated: 1991
- WPTP, Yard Piping Drawings (1,2,3), King County WTD, dated: 1996

Equipment Quotes:

- Aeration Blowers, Equipment Quotation, Next Turbo, dated: 09.27.19
- MBR, Equipment Quotation, Suez, dated: 10.01.19
- PE Screens, Equipment Quotation, Huber Technology, dated: 10.02.19
- Sidestream Anammox, Equipment Quotation, Ovivo, dated: 09.06.19



# King County

Department of Natural Resources and Parks  
Wastewater Treatment Division

## Project Planning and Delivery Section

### BASIS OF ESTIMATE

---

Project Name	<b>West Point Treatment Plant Nitrogen Removal - Alternative 2A</b>
Project Number	
Date Prepared	March 05, 2020
Requested by	Tiffany Knapp, King County WTD
Prepared by	Douglas W. Leo, CCP, CEP, FRICS, FAACE Hon. Life, (VMS, Inc.)
Estimate Classification	WTD Class 5
Estimate Purpose	King County Class 5 Concept Screening
Estimate ID (Version)	7
Project Manager	Eron Jacobson, King County WTD
Project Control Engineer	
Cc or Distribution List	

*Note that the accuracy of the associated cost estimate is dependent upon the various underlying assumptions, inclusions, and exclusions described herein. Actual project costs may differ and can be significantly affected by factors such as changes in the external environment, the manner in which the project is executed and controlled, and other factors that may impact the estimate basis or otherwise affect the project. Estimate accuracy ranges are only assessments based upon the cost estimating methods and data employed in preparing the estimate and are not a guarantee of actual project costs.*

## BASIS OF ESTIMATE

Project Name	<b>West Point Treatment Plant Nitrogen Removal - Alternative 2A</b>		
Project Number:		Date:	March 05, 2020

### 1.0 Purpose

---

The purpose of this estimate is to provide cost information to support King County's West Point Treatment Plant (WPTP) Flows and Loading Alternative Evaluation for the Nitrogen Removal Project. A series of alternatives have been developed for project evaluation to determine the best engineering and project cost solution.

This estimate was prepared to establish a King County Wastewater Treatment Division (WTD) pre-Class 5 conceptual cost estimate to provide order of magnitude cost to support WTD's capital project identification and budgeting process for Total Project Costs. The WTD pre-Class 5 estimate provides similar documentation to that of an AACE International Class 5 estimate. The range of anticipated project costs, per WTD estimating guidance, is -50% / +300%. The range of uncertainty is beyond that for a typical Class 5 estimate due to the scope being proximally defined with today's relative solutions and technologies to resolving the identified needs; when the projects move forward into capital delivery over the longer term, it is anticipated that many differences and changes may arise as the known and defined engineering solutions are developed.

Douglas Leo of Value Management Strategies, Inc. (VMS) prepared this Basis of Estimate in coordination with King County WTD, the Brown and Caldwell Engineers team, and the VMS estimating team after receiving scope information from WTD in October 2019 through March 2020. This Basis of Estimate reflects VMS's best understanding of the estimating process for this project, as explained by King County WTD and Brown and Caldwell.

### 2.0 Project Scope Definition

---

This estimate includes all investigation, administration/owners' costs, engineering and design, purchases, fabrications, installations, process certifications, permitting, community impacts, and miscellaneous costs not specifically excluded elsewhere in this document.

Comprehensive Total Field Costs are generated from historical allowances, sources such as WTD estimating tools, historical costs, and RS Means/VMS estimating databases. All supporting indirect costs were generated from the WTD PRISM historical database. All costs included in the estimate reflect the best understanding of requirements as they existed at the time this estimate was prepared.

The scope of Alternative 2A is to provide year-round nitrogen removal (MLE/MBR) and the lowest effluent TIN possible while maintain the existing secondary treatment capacity. The scope was developed to a Conceptual Design level adequate to assess operations and maintenance issues, energy impacts, permitting and code compliance issues, constructability, and estimated costs.

The Project Estimate was prepared utilizing the following Work Breakdown Structure (WBS) in order to provide clarity and transparency to the estimated costs. The scope as identified for the alternative is described below in accordance with the WBS. Details are based on the known and defined scope in the design documents provided. See section 3.0 for a detailed list of Design Documents.

- A. Primary Effluent (PE)
  - New Drum Screens – purchase and install
  - New PE Fine Screening Facility – 11,700 square feet
  - Demolish Clarifier 12 and 13
  - Contractor Permit Fees at 1.0% Direct Costs
- B. Aeration Basins
  - General
    - Demolish Existing Aerators

## BASIS OF ESTIMATE

Project Name	<b>West Point Treatment Plant Nitrogen Removal - Alternative 2A</b>		
Project Number:		Date:	March 05, 2020

- New Aeration Basin Trains – purchase and install
  - Aeration Basin Interior Walls
  - Aeration Basin Retention Wall – purchase and install
  - Contractor Permit Fees at 1.0% Direct Costs
- C. Membrane Basins
- Membrane System – purchase and install
  - MBR Bridge Crane and Rails
  - Concrete Membrane Vault Basins – purchase and install
  - Membrane Vault Basin Interior Walls
  - Contractor Permit Fees at 1.0% Direct Costs
- D. Internal Mixed Liquor Return (IMLR) Pumping
- IMLR Pump
  - 60" CS Pipe per Basin
  - Contractor Permit Fees at 1.0% Direct Costs
- E. Return Activated Sludge (RAS) Pump
- North RAS Pump Station Building – 2,317 square feet.
  - South RAS Pump Station Building – 4,362 square feet.
  - Demolish RAS Pumps and Clarifiers
  - Contractor Permit Fees at 1.0% Direct Costs
- F. Sidestream Anammox
- *Not included in the scope for this alternative.*
- G. Supplemental Methanol System
- Supplemental Methanol 60,000-gallon System – purchase and install
  - Contractor Permit Fees at 1.0% Direct Costs
- H. Supplemental Alkalinity System
- Supplemental Alkalinity 90,000-gallon System – purchase and install
  - Contractor Permit Fees at 1.0% Direct Costs
- I. Aeration Blowers
- Aeration Blowers – purchase and install
  - Aeration Blower Diffusers – purchase and install
  - Demolition allowance
  - Contractor Permit Fees at 1.0% Direct Costs
- J. Aeration Basin Mixers for Anoxic Zones
- Aeration Basin Mixers – purchase and install
  - Contractor Permit Fees at 1.0% Direct Costs
- K. Sidestream Bioaugmentation
- *Not included in the scope for this alternative.*
- L. Tertiary Pumps
- *Not included in the scope for this alternative.*
- M. Tertiary Fixed Film System
- *Not included in the scope for this alternative.*
- N. Aeration / MBR Odor Control
- *Not included in the scope for this alternative.*

## BASIS OF ESTIMATE

Project Name	<b>West Point Treatment Plant Nitrogen Removal - Alternative 2A</b>		
Project Number:		Date:	March 05, 2020

- O. Primary Clarifier / Aerated Grit Tank
  - *Not included in the scope for this alternative.*
  
- P. Miscellaneous Scope
  - Parking Garage to Accommodate 30 Spaces
  - Allowance for Electrical Power Upgrades
  - Temporary Dock
  - Large Crane at Loading Dock
  - Barge Charges with Tug
  - RAS Channel to Aeration Basins
  - Methanol Piping
  - Aeration Air to Aeration Basin
  - 132-inch RCP Pipe Extension, Valves and Controls – purchase and install
  - PE Pipe
  - Centrate to Anammox
  - Archeological Services
  - Site Mitigation
  - Tribal Agreements
  - Contractor Permit Fees at 1.0% Direct Costs

### 3.0 Design Basis

---

This is an AACE International Class 5 estimate with all required documentation. The estimate is based on engineering deliverables, scoping documentation, discussions with the project team, and all supporting information and documentation provided in October 2019 through March 2020.

Engineering conceptual scope was provided in the following estimating deliverables. These are the most complete scoping documents that were available to the estimating provider.

Engineering and Estimating Deliverables provided include:

- West Point Treatment Process, King County WTD
- Scope Questions to Brown Caldwell – answered 10.17.19
- Brown & Caldwell Markup, Existing HPO Retrofit Assumptions for MLE (Alt 2A/2B/3A/4A/4C)
- Brown & Caldwell Markup, Existing HPO Retrofit Assumptions for 4SMB (Alt 2C/3D/4D/4E)
- Brown & Caldwell Markup, Existing HPO Aerator Demo
- Brown & Caldwell Markup, Existing Secondary Clarifier Demo (Alt 2A/2B/2C)
- Brown & Caldwell Markup, Existing RAS Pumps Demo (Alt 2A/2B/2C/3A/3D)
- Brown & Caldwell Markup, Existing Liquid Oxygen Tanks Demo (All Alt. except Alt 1)
- Brown & Caldwell Markup, Existing Oxygen Generation Facility Demo (All Alt except Alt 1)
- WPTP Nitrogen Removal Study, Layout Flow Paths, Brown and Caldwell, All Alternatives
- WPTP Nitrogen Removal Study, All Layouts, Brown and Caldwell, All Alternatives
- Anammox Equipment, Budgetary Price, Brown and Caldwell, All Alternatives
- BW Reference Drawings, Brown & Caldwell, dated: 10.20.2006
- WPTP, Cost Estimating Assumptions, Brown & Caldwell, version 0
- Aeration Basin Mechanical Drawings Package, King County WTD, dated: 1991
- Aeration Basin Structural Drawings, King County WTD, dated: 1991
- WPTP, Drawing Location Numbers, King County WTD, dated: 04.26.2018

## **BASIS OF ESTIMATE**

Project Name	<b>West Point Treatment Plant Nitrogen Removal - Alternative 2A</b>		
Project Number:		Date:	March 05, 2020

- WPTP, Facility Plan, King County WTD, dated: 07.2017
- WPTP, Oxygen Generation Bldg. Drawings, King County WTD, dated: 1992
- WPTP, Perspective Overview, King County WTD, dated: 02.24.2017
- WPTP, Secondary Clarifiers Drawings, King County WTD, dated: 1991
- WPTP, Yard Piping Drawings (1,2,3), King County WTD, dated: 1996

### Equipment Quotes:

- Aeration Blowers, Equipment Quotation, Next Turbo, dated: 09.27.19
- MBR, Equipment Quotation, Suez, dated: 10.01.19
- PE Screens, Equipment Quotation, Huber Technology, dated: 10.02.19
- Sidestream Anammox, Equipment Quotation, Ovivo, dated: 09.06.19

## **4.0 Planning Basis**

---

The following planning basis assumptions were made for the project estimate:

- No project construction plan is in place at this time.
- The assumed execution strategy is a standard workweek with limited overtime.
- No unusual site conditions have been considered as part of this estimate.
- Adequate available power exists at the site.

## **5.0 Cost Basis**

---

- All allied and indirect project costs (allowances for indeterminates, change order allowance, engineering, permitting, WTD staffing, etc.) have been estimated using WTD's PRISM cost model which is baselined to historical project costs.
- The estimate was performed based on drawings, sketches, and project information provided by King County and Brown and Caldwell Engineers.
- WTD is using a PRISM cost model dated January 26, 2017. All Allied and indirect project costs have been estimated using the new WTD PRISM cost model baselined to historical project costs.
- Additional technical project complexity factors for WTD indirect project costs have been introduced and incorporated into project allied costs to allow for development of an additional WTD indirect cost allowance, based upon the unique characteristics of the project.
- Equipment factors were developed utilizing historical data which accounts for specific install of the identified equipment within a normal battery limit. Specific scope relative to this project was used in the equipment factor determination. Factors for each specific type of equipment reflect the different complexity of the installation. Engineering supplied equipment costs were multiplied by the factors in order to estimate direct construction cost for the purchase and install of the equipment.
- Estimated costs incorporate prevailing King County wage rates.
- All costs were estimated in 1<sup>st</sup> quarter 2020 dollars.



## BASIS OF ESTIMATE

Project Name	<b>West Point Treatment Plant Nitrogen Removal - Alternative 2A</b>		
Project Number:		Date:	March 05, 2020

### 6.0 Allowances

---

The level and types of allowances used in the estimate is as follows (common percentages for each alternative are shown and any estimate-specific differences are indicated):

- Sales Tax was included as 10.1% applied to the base construction cost, including the design and change order contingencies.
- A 25% Allowance for Indeterminates (AFI) is applied to the base construction cost. The AFI is an allowance that accounts for the cost of known but undefined requirements necessary for a complete and workable project. The AFI accounts for elements that are not explicitly shown in the project documents to be further defined as part of the design development and project delivery process. The AFI is carried at 25% at conceptual design, based on the WTD project delivery process.
- Allowance of 10% for potential construction change orders.
- Allowance of 0.2% of the primary construction amount for miscellaneous direct capital costs.
- Allowance of 1.5% of the primary construction amount for permitting and other agency support.
- Allowance of 1.8% of the primary construction amount for miscellaneous services and material.
- Allowance of 0.65% of the primary construction amount for Non-WTD Support.
- Allowance of 1.0% of the primary construction amount for art initiatives.
- Allowance of 0.5% of the total project cost for sustainability.
- Allowance of 18.32% of the primary construction amount for Engineering Design Services.
- Allowance of 6.73% of the primary construction amount for Construction Management Services.
- Allowance of 16.34% of the primary construction amount for WTD Staff.
- Allowance of 1% of Directs Costs was included for Contractor Permit Fees.
- Allowance for application of total project contingency (see *Contingency* section below).
- Allowance of 0% was included for Escalation as the estimate is produced in current year (2020) dollars.
- Additional estimating allowances for WTD indirect costs of approximately \$247.54 million have been included in the Total Project Cost estimate by using a moderate degree of complexity rating for Project Controls and a high degree of complexity rating for all other indirect costs. Complexity factors were calibrated based on comments received from King County on March 4, 2020.
  - An allowance of \$161.80 million for Design and Construction Consulting
  - An allowance of \$13.69 million for Permitting & Other Agency Support
  - An allowance of \$72.04 million for WTD Staff Labor

## **BASIS OF ESTIMATE**

Project Name	<b>West Point Treatment Plant Nitrogen Removal - Alternative 2A</b>		
Project Number:		Date:	March 05, 2020

### **7.0 Assumptions**

---

Any other assumptions made by the estimator but not documented elsewhere in the estimate basis are included in this section.

- All costs included in the estimate reflect the best understanding of requirements as they existed at the time the estimates were prepared. Any modifications to the present scope and/or location of the project site may have substantial cost and schedule impacts.
- The engineering design will be performed by an external consultant engineer.
- Construction management will not be performed “in-house” by WTD. It will be performed by an external consultant construction manager.
- The project will generally align with the WTD PRISM cost model for Treatment projects.
- All work will always be performed utilizing safe work methods.
- Work will be sequenced to minimize standard process, service and community interruptions. However, no costs are included to address sequencing necessary keep the plant operational during construction.
- No costs are included for any new facilities that would be required, beyond the scope of this project to replace any lost capacity to the WPTP.
- It is assumed that the best improvement solution is included in the project scope(s).
- There will be some degree of productivity loss due to the site location. Some degree of productivity loss is included in the estimated costs. Any unusual site conditions are not accounted for in this estimate.
- Any additional work discovered during project implementation would need to be either a supplemental approval of added scope or be approved as an additional project.
- This project will be engineered to meet Washington State area seismic requirements.
- A degree of minimal cost rounding will occur during the normal estimating process.
- No allowance is included for Material Pricing Uncertainty.
- Power is readily available in the general area of this project. No new power sources are included in the scope of this project.
- It is assumed that some general material contamination is present. The estimate covers minimal cost of removal wherever the contamination is disturbed during construction. This cost is covered in productivity rates utilized in the estimate.
- It is assumed that the scope only requires 2” dia. methanol piping instead of any concrete channel structure.

### **8.0 Exclusions**

---

All potential items of cost which might be associated with the project but for which no costs have been included are listed below:

- No asbestos removal costs are included.
- No estimated costs are included for any potential delays due to interferences.

## BASIS OF ESTIMATE

Project Name	<b>West Point Treatment Plant Nitrogen Removal - Alternative 2A</b>		
Project Number:		Date:	March 05, 2020

- No costs are included for utility relocations.
- No costs are included for temporary construction easements.
- No costs are included for street use or street improvement permits.
- No costs are included for additional scope beyond that as detailed in the current scope of work.

### 9.0 Exceptions

---

This estimate is classified as a King County Wastewater Treatment Division Class 5 estimate based on an AACE International Class 5 estimate, with no exceptions per the King County WTD project process, for the scope as known at the time of the estimate preparation.

### 10.0 Risks (Threats and Opportunities)

---

At the time of estimate preparation, a formal risk analysis session had not been conducted. General potential risks are listed below.

- There is a risk that additional scope, technology advances or major deviation from the suggested project scope will adversely impact cost and schedule.
- Future unknown or changing site conditions present a risk around productivities, schedule, and costs.
- More stringent or completely new regulations, usage fees, permitting, or environmental impacts may result in risks that could adversely impact cost and schedule.
- Potential complex construction and constructability issues could arise during construction, resulting in major design/construction changes.
- The space constraints could significantly impact assumed productivities and crew sizes identified for the estimated concept, resulting in increased costs due to loss of production.
- The scheduled timing of project execution will greatly impact the bottom-line costs. There is risk related to labor availability and fluctuating commodity and equipment pricing in the timeframe between this early conceptual estimate and the actual execution of the project. Rising costs due to inflation, escalation and competing major worldwide projects pose the possibility of noticeable project cost and schedule increases.
- Weather conditions and emergency service interruptions present the possibility of negative schedule and cost impacts.
- Any possible coordination with other agencies could result in potential impacts on costs, schedule and Project Definition process.
- There is a risk that stakeholders could oppose the proposed design or prefer a different approach or site to be selected, resulting in schedule delays and a higher cost alternative.

## **BASIS OF ESTIMATE**

Project Name	<b>West Point Treatment Plant Nitrogen Removal - Alternative 2A</b>		
Project Number:		Date:	March 05, 2020

### **11.0 Contingency**

---

Contingency is a cost element of the estimate used to cover uncertainties and unforeseeable elements of cost within the defined project scope. Contingency covers inadequacies in project scope definition, estimating methods, and estimating data. Contingency specifically excludes changes in project scope, and unforeseen major events such as earthquakes, prolonged labor strikes, etc.

A 30% Project Contingency was added to the base estimate of Total Project Costs (direct and indirect) as a result of the project estimating process and in accordance with the King County WTD project delivery process.

The estimating analysis resulted in a project contingency of approximately \$650.60 million (US\$).

The total project cost at a 50% confidence level (P50) is typically used for funding and baselining of a project at this stage and level of engineering and project development. The P50 confidence level suggests that there is a 50% cumulative probability of project cost under-run (or 50% probability of exceedance) at this dollar amount for the presently defined and known project scope.

### **12.0 Management Reserve**

---

No allocation of costs was included in this estimate for Management Reserves.

Contingency is not intended to cover the costs for changes in project scope. If the project needs to provide an allowance for anticipated changes in scope or to cover the costs for items that may be required but have not yet been specifically identified as being included in the current project scope, then that amount of cost should be identified here.

### **13.0 Reconciliation**

---

Reconciliation was not conducted at this time.

### **14.0 Benchmarking**

---

All included Allied Costs as supplied by the PRISM historical database have been benchmarked against a similar portfolio of recently completed projects.

### **15.0 Estimate Quality Assurance Plan**

---

No reviews of total project costs have been conducted outside the reviews conducted within Brown and Caldwell and VMS estimating team. It is anticipated that upon completion of this estimate, reviews will happen between the estimate provider and WTD.

### **16.0 Attachments**

---

#### **Attachment: Estimate Deliverables**

Engineering and Estimating Deliverables provided include:

- West Point Treatment Process, King County WTD
- Scope Questions to Brown Caldwell – answered 10.17.19

## BASIS OF ESTIMATE

Project Name	<b>West Point Treatment Plant Nitrogen Removal - Alternative 2A</b>		
Project Number:		Date:	March 05, 2020

- Brown & Caldwell Markup, Existing HPO Retrofit Assumptions for MLE (Alt 2A/2B/3A/4A/4C)
- Brown & Caldwell Markup, Existing HPO Retrofit Assumptions for 4SMB (Alt 2C/3D/4D/4E)
- Brown & Caldwell Markup, Existing HPO Aerator Demo
- Brown & Caldwell Markup, Existing Secondary Clarifier Demo (Alt 2A/2B/2C)
- Brown & Caldwell Markup, Existing RAS Pumps Demo (Alt 2A/2B/2C/3A/3D)
- Brown & Caldwell Markup, Existing Liquid Oxygen Tanks Demo (All Alt. except Alt 1)
- Brown & Caldwell Markup, Existing Oxygen Generation Facility Demo (All Alt except Alt 1)
- WPTP Nitrogen Removal Study, Layout Flow Paths, Brown and Caldwell, All Alternatives
- WPTP Nitrogen Removal Study, All Layouts, Brown and Caldwell, All Alternatives
- Anammox Equipment, Budgetary Price, Brown and Caldwell, All Alternatives
- BW Reference Drawings, Brown & Caldwell, dated: 10.20.2006
- WPTP, Cost Estimating Assumptions, Brown & Caldwell, version 0
- Aeration Basin Mechanical Drawings Package, King County WTD, dated: 1991
- Aeration Basin Structural Drawings, King County WTD, dated: 1991
- WPTP, Drawing Location Numbers, King County WTD, dated: 04.26.2018
- WPTP, Facility Plan, King County WTD, dated: 07.2017
- WPTP, Oxygen Generation Bldg. Drawings, King County WTD, dated: 1992
- WPTP, Perspective Overview, King County WTD, dated: 02.24.2017
- WPTP, Secondary Clarifiers Drawings, King County WTD, dated: 1991
- WPTP, Yard Piping Drawings (1,2,3), King County WTD, dated: 1996

### Equipment Quotes:

- Aeration Blowers, Equipment Quotation, Next Turbo, dated: 09.27.19
- MBR, Equipment Quotation, Suez, dated: 10.01.19
- PE Screens, Equipment Quotation, Huber Technology, dated: 10.02.19
- Sidestream Anammox, Equipment Quotation, Ovivo, dated: 09.06.19



# King County

Department of Natural Resources and Parks  
Wastewater Treatment Division

## Project Planning and Delivery Section

### BASIS OF ESTIMATE

---

Project Name	<b>West Point Treatment Plant Nitrogen Removal - Alternative 2B</b>
Project Number	
Date Prepared	March 05, 2020
Requested by	Tiffany Knapp, King County WTD
Prepared by	Douglas W. Leo, CCP, CEP, FRICS, FAACE Hon. Life, (VMS, Inc.)
Estimate Classification	WTD Class 5
Estimate Purpose	King County Class 5 Concept Screening
Estimate ID (Version)	7
Project Manager	Eron Jacobson, King County WTD
Project Control Engineer	
Cc or Distribution List	

*Note that the accuracy of the associated cost estimate is dependent upon the various underlying assumptions, inclusions, and exclusions described herein. Actual project costs may differ and can be significantly affected by factors such as changes in the external environment, the manner in which the project is executed and controlled, and other factors that may impact the estimate basis or otherwise affect the project. Estimate accuracy ranges are only assessments based upon the cost estimating methods and data employed in preparing the estimate and are not a guarantee of actual project costs.*



## **BASIS OF ESTIMATE**

Project Name	<b>West Point Treatment Plant Nitrogen Removal - Alternative 2B</b>		
Project Number:		Date:	March 05, 2020

### **1.0 Purpose**

---

The purpose of this estimate is to provide cost information to support King County's West Point Treatment Plant (WPTP) Flows and Loading Alternative Evaluation for the Nitrogen Removal Project. A series of alternatives have been developed for project evaluation to determine the best engineering and project cost solution.

This estimate was prepared to establish a King County Wastewater Treatment Division (WTD) pre-Class 5 conceptual cost estimate to provide order of magnitude cost to support WTD's capital project identification and budgeting process for Total Project Costs. The WTD pre-Class 5 estimate provides similar documentation to that of an AACE International Class 5 estimate. The range of anticipated project costs, per WTD estimating guidance, is -50% / +300%. The range of uncertainty is beyond that for a typical Class 5 estimate due to the scope being proximally defined with today's relative solutions and technologies to resolving the identified needs; when the projects move forward into capital delivery over the longer term, it is anticipated that many differences and changes may arise as the known and defined engineering solutions are developed.

Douglas Leo of Value Management Strategies, Inc. (VMS) prepared this Basis of Estimate in coordination with King County WTD, the Brown and Caldwell Engineers team, and the VMS estimating team after receiving scope information from WTD in October 2019 through March 2020. This Basis of Estimate reflects VMS's best understanding of the estimating process for this project, as explained by King County WTD and Brown and Caldwell.

### **2.0 Project Scope Definition**

---

This estimate includes all investigation, administration/owners' costs, engineering and design, purchases, fabrications, installations, process certifications, permitting, community impacts, and miscellaneous costs not specifically excluded elsewhere in this document.

Comprehensive Total Field Costs are generated from historical allowances, sources such as WTD estimating tools, historical costs, and RS Means/VMS estimating databases. All supporting indirect costs were generated from the WTD PRISM historical database. All costs included in the estimate reflect the best understanding of requirements as they existed at the time this estimate was prepared.

The scope of Alternative 2B is to provide year-round nitrogen removal (MLE/MBR and Sidestream Anammox) and the lowest effluent TIN possible while maintain the existing secondary treatment capacity. The scope was developed to a Conceptual Design level adequate to assess operations and maintenance issues, energy impacts, permitting and code compliance issues, constructability, and estimated costs.

The Project Estimate was prepared utilizing the following Work Breakdown Structure (WBS) in order to provide clarity and transparency to the estimated costs. The scope as identified for the alternative is described below in accordance with the WBS. Details are based on the known and defined scope in the design documents provided. See section 3.0 for a detailed list of Design Documents.

- A. Primary Effluent (PE)
  - New Drum Screens – purchase and install
  - New PE Fine Screening Facility - 11,700 square feet.
  - Demolish Clarifier 12 and 13
  - Contractor Permit Fees at 1.0% Direct Costs
- B. Aeration Basins
  - General
    - Demolish Existing Aerators

## BASIS OF ESTIMATE

Project Name	<b>West Point Treatment Plant Nitrogen Removal - Alternative 2B</b>		
Project Number:		Date:	March 05, 2020

- New Aeration Basin Trains – purchase and install
  - Aeration Basin Interior Walls
  - Aeration Basin Retention Wall – purchase and install
  - Contractor Permit Fees at 1.0% Direct Costs
- C. Membrane Basins
- Membrane System – purchase and install
  - MBR Bridge Crane and Rails
  - Concrete Membrane Vault Basins – purchase and install
  - Membrane Vault Basin Interior Walls
  - Contractor Permit Fees at 1.0% Direct Costs
- D. Internal Mixed Liquor Return (IMLR) Pumping
- IMLR Pump
  - 60"CS Pipe per Aeration Basin
  - Contractor Permit Fees at 1.0% Direct Costs
- E. Return Activated Sludge (RAS) Pump
- North RAS Pump Station Building – 2317 square feet
  - South RAS Pump Station Building – 4362 square feet
  - Demolish RAS Pumps and Clarifiers
  - Contractor Permit Fees at 1.0% Direct Costs
- F. Sidestream Anammox
- Sidestream Anammox – purchase and install
  - Pumps / Skimmer / Chain / Flight for Sedimentation Tank / Mixers – purchase and install
  - Centrate EQ Tank (80,000-gal) – purchase and install
  - Centrate Sedimentation Tank (151,000-gal) – purchase and install
  - Anammox Reactor Tanks (375,000-gal) – purchase and install
  - Contractor Permit Fees at 1.0% Direct Costs
- G. Supplemental Methanol System
- Supplemental Methanol 45,000-gallon System – purchase and install
  - Contractor Permit Fees at 1.0% Direct Costs
- H. Supplemental Alkalinity System
- Supplemental Alkalinity 90,000-gallon System – purchase and install
  - Contractor Permit Fees at 1.0% Direct Costs
- I. Aeration Blowers
- Aeration Blowers – purchase and install
  - Aeration Blower Diffusers – purchase and install
  - Demolition Allowance
  - Contractor Permit Fees at 1.0% Direct Costs
- J. Aeration Basin Mixers for Anoxic Zones
- Aeration Basin Mixers – purchase and install
  - Contractor Permit Fees at 1.0% Direct Costs
- K. Sidestream Bioaugmentation
- *Not included in the scope for this alternative.*
- L. Tertiary Pumps

## BASIS OF ESTIMATE

Project Name	<b>West Point Treatment Plant Nitrogen Removal - Alternative 2B</b>		
Project Number:		Date:	March 05, 2020

- *Not included in the scope for this alternative.*
- M. Tertiary Fixed Film System
  - *Not included in the scope for this alternative.*
- N. Aeration / MBR Odor Control
  - *Not included in the scope for this alternative.*
- O. Primary Clarifier / Aerated Grit Tank
  - *Not included in the scope for this alternative.*
- P. Miscellaneous Scope
  - Parking Garage to Accommodate 30 Spaces
  - Allowance for Electrical Power Upgrades
  - Temporary Dock
  - Large Crane at Loading Dock
  - Barge Charges with Tug
  - RAS Channel to Aeration Basins
  - Methanol Piping
  - Aeration Air to Aeration Basin
  - 132-inch RCP Pipe Extension, Valves and Controls – purchase and install
  - PE Pipe
  - Centrate to Anammox
  - Archeological Services
  - Site mitigation
  - Tribal Agreements
  - Contractor Permit Fees at 1.0% Direct Costs

### 3.0 Design Basis

---

This is an AACE International Class 5 estimate with all required documentation. The estimate is based on engineering deliverables, scoping documentation, discussions with the project team, and all supporting information and documentation provided in October 2019 through March 2020.

Engineering conceptual scope was provided in the following estimating deliverables. These are the most complete scoping documents that were available to the estimating provider.

Engineering and Estimating Deliverables provided include:

- West Point Treatment Process, King County WTD
- Scope Questions to Brown Caldwell – answered 10.17.19
- Brown & Caldwell Markup, Existing HPO Retrofit Assumptions for MLE (Alt 2A/2B/3A/4A/4C)
- Brown & Caldwell Markup, Existing HPO Retrofit Assumptions for 4SMB (Alt 2C/3D/4D/4E)
- Brown & Caldwell Markup, Existing HPO Aerator Demo
- Brown & Caldwell Markup, Existing Secondary Clarifier Demo (Alt 2A/2B/2C)
- Brown & Caldwell Markup, Existing RAS Pumps Demo (Alt 2A/2B/2C/3A/3D)
- Brown & Caldwell Markup, Existing Liquid Oxygen Tanks Demo (All Alt. except Alt 1)
- Brown & Caldwell Markup, Existing Oxygen Generation Facility Demo (All Alt except Alt 1)
- WPTP Nitrogen Removal Study, Layout Flow Paths, Brown and Caldwell, All Alternatives
- WPTP Nitrogen Removal Study, All Layouts, Brown and Caldwell, All Alternatives

## BASIS OF ESTIMATE

Project Name	<b>West Point Treatment Plant Nitrogen Removal - Alternative 2B</b>		
Project Number:		Date:	March 05, 2020

- Anammox Equipment, Budgetary Price, Brown and Caldwell, All Alternatives
- BW Reference Drawings, Brown & Caldwell, dated: 10.20.2006
- WPTP, Cost Estimating Assumptions, Brown & Caldwell, version 0
- Aeration Basin Mechanical Drawings Package, King County WTD, dated: 1991
- Aeration Basin Structural Drawings, King County WTD, dated: 1991
- WPTP, Drawing Location Numbers, King County WTD, dated: 04.26.2018
- WPTP, Facility Plan, King County WTD, dated: 07.2017
- WPTP, Oxygen Generation Bldg. Drawings, King County WTD, dated: 1992
- WPTP, Perspective Overview, King County WTD, dated: 02.24.2017
- WPTP, Secondary Clarifiers Drawings, King County WTD, dated: 1991
- WPTP, Yard Piping Drawings (1,2,3), King County WTD, dated: 1996

### Equipment Quotes:

- Aeration Blowers, Equipment Quotation, Next Turbo, dated: 09.27.19
- MBR, Equipment Quotation, Suez, dated: 10.01.19
- PE Screens, Equipment Quotation, Huber Technology, dated: 10.02.19
- Sidestream Anammox, Equipment Quotation, Ovivo, dated: 09.06.19

## 4.0 Planning Basis

---

The following planning basis assumptions were made for the project estimate:

- No project construction plan is in place at this time.
- The assumed execution strategy is a standard workweek with limited overtime.
- No unusual site conditions have been considered as part of this estimate.
- Adequate available power exists at the site.

## 5.0 Cost Basis

---

- All allied and indirect project costs (allowances for indeterminates, change order allowance, engineering, permitting, WTD staffing, etc.) have been estimated using WTD's PRISM cost model which is baselined to historical project costs.
- The estimate was performed based on drawings, sketches, and project information provided by King County and Brown and Caldwell Engineers.
- WTD is using a PRISM cost model dated January 26, 2017. All Allied and indirect project costs have been estimated using the new WTD PRISM cost model baselined to historical project costs.
- Additional technical project complexity factors for WTD indirect project costs have been introduced and incorporated into project allied costs to allow for development of an additional WTD indirect cost allowance, based upon the unique characteristics of the project.
- Equipment factors were developed utilizing historical data which accounts for specific install of the identified equipment within a normal battery limit. Specific scope relative to this project was used in the equipment factor determination. Factors for each specific type of equipment reflect the different complexity of the installation. Engineering supplied equipment costs were multiplied

## BASIS OF ESTIMATE

Project Name	<b>West Point Treatment Plant Nitrogen Removal - Alternative 2B</b>		
Project Number:		Date:	March 05, 2020

by the factors in order to estimate direct construction cost for the purchase and install of the equipment.

- Estimated costs incorporate prevailing King County wage rates.
- All costs were estimated in 1<sup>st</sup> quarter 2020 dollars.

### 6.0 Allowances

---

The level and types of allowances used in the estimate is as follows (common percentages for each alternative are shown and any estimate-specific differences are indicated):

- Sales Tax was included as 10.1% applied to the base construction cost, including the design and change order contingencies.
- A 25% Allowance for Indeterminates (AFI) is applied to the base construction cost. The AFI is an allowance that accounts for the cost of known but undefined requirements necessary for a complete and workable project. The AFI accounts for elements that are not explicitly shown in the project documents to be further defined as part of the design development and project delivery process. The AFI is carried at 25% at conceptual design, based on the WTD project delivery process.
- Allowance of 10% for potential construction change orders.
- Allowance of 0.2% of the primary construction amount for miscellaneous direct capital costs.
- Allowance of 1.5% of the primary construction amount for permitting and other agency support.
- Allowance of 1.8% of the primary construction amount for miscellaneous services and material.
- Allowance of 0.65% of the primary construction amount for Non-WTD Support.
- Allowance of 1.0% of the primary construction amount for art initiatives.
- Allowance of 0.5% of the total project cost for sustainability.
- Allowance of 18.26% of the primary construction amount for Engineering Design Services.
- Allowance of 6.70% of the primary construction amount for Construction Management Services.
- Allowance of 16.31% of the primary construction amount for WTD Staff.
- Allowance of 1% of Directs Costs was included for Contractor Permit Fees.
- Allowance for application of total project contingency (see *Contingency* section below).
- Allowance of 0% was included for Escalation as the estimate is produced in current year (2020) dollars.
- Additional estimating allowances for WTD indirect costs of approximately \$252.63 million have been included in the Total Project Cost estimate by using a moderate degree of complexity rating for Project Controls and a high degree of complexity rating for all other indirect costs. Complexity factors were calibrated based on comments received from King County on March 4, 2020.
  - An allowance of \$164.60 million for Design and Construction Consulting
  - An allowance of \$13.98 million for Permitting & Other Agency Support

## BASIS OF ESTIMATE

Project Name	<b>West Point Treatment Plant Nitrogen Removal - Alternative 2B</b>		
Project Number:		Date:	March 05, 2020

- An allowance of \$73.47 million for WTD Staff Labor

### 7.0 Assumptions

---

Any other assumptions made by the estimator but not documented elsewhere in the estimate basis are included in this section.

- All costs included in the estimate reflect the best understanding of requirements as they existed at the time the estimates were prepared. Any modifications to the present scope and/or location of the project site may have substantial cost and schedule impacts.
- The engineering design will be performed by an external consultant engineer.
- Construction management will not be performed “in-house” by WTD. It will be performed by an external consultant construction manager.
- The project will generally align with the WTD PRISM cost model for Treatment projects.
- All work will always be performed utilizing safe work methods.
- Work will be sequenced to minimize standard process, service and community interruptions. However, no costs are included to address sequencing necessary keep the plant operational during construction.
- No costs are included for any new facilities that would be required, beyond the scope of this project to replace any lost capacity to the WPTP.
- It is assumed that the best improvement solution is included in the project scope(s).
- There will be some degree of productivity loss due to the site location. Some degree of productivity loss is included in the estimated costs. Any unusual site conditions are not accounted for in this estimate.
- Any additional work discovered during project implementation would need to be either a supplemental approval of added scope or be approved as an additional project.
- This project will be engineered to meet Washington State area seismic requirements.
- A degree of minimal cost rounding will occur during the normal estimating process.
- No allowance is included for Material Pricing Uncertainty.
- Power is readily available in the general area of this project. No new power sources are included in the scope of this project.
- It is assumed that some general material contamination is present. The estimate covers minimal cost of removal wherever the contamination is disturbed during construction. This cost is covered in productivity rates utilized in the estimate.
- It is assumed that the scope only requires 2” dia. methanol piping instead of any concrete channel structure.

### 8.0 Exclusions

---

All potential items of cost which might be associated with the project but for which no costs have been included are listed below:



## BASIS OF ESTIMATE

Project Name	<b>West Point Treatment Plant Nitrogen Removal - Alternative 2B</b>		
Project Number:		Date:	March 05, 2020

- No asbestos removal costs are included.
- No estimated costs are included for any potential delays due to interferences.
- No costs are included for utility relocations.
- No costs are included for temporary construction easements.
- No costs are included for street use or street improvement permits.
- No costs are included for additional scope beyond that as detailed in the current scope of work.

### 9.0 Exceptions

---

This estimate is classified as a King County Wastewater Treatment Division Class 5 estimate based on an AACE International Class 5 estimate, with no exceptions per the King County WTD project process, for the scope as known at the time of the estimate preparation.

### 10.0 Risks (Threats and Opportunities)

---

At the time of estimate preparation, a formal risk analysis session had not been conducted. General potential risks are listed below.

- There is a risk that additional scope, technology advances or major deviation from the suggested project scope will adversely impact cost and schedule.
- Future unknown or changing site conditions present a risk around productivities, schedule, and costs.
- More stringent or completely new regulations, usage fees, permitting, or environmental impacts may result in risks that could adversely impact cost and schedule.
- Potential complex construction and constructability issues could arise during construction, resulting in major design/construction changes.
- The space constraints could significantly impact assumed productivities and crew sizes identified for the estimated concept, resulting in increased costs due to loss of production.
- The scheduled timing of project execution will greatly impact the bottom-line costs. There is risk related to labor availability and fluctuating commodity and equipment pricing in the timeframe between this early conceptual estimate and the actual execution of the project. Rising costs due to inflation, escalation and competing major worldwide projects pose the possibility of noticeable project cost and schedule increases.
- Weather conditions and emergency service interruptions present the possibility of negative schedule and cost impacts.
- Any possible coordination with other agencies could result in potential impacts on costs, schedule and Project Definition process.
- There is a risk that stakeholders could oppose the proposed design or prefer a different approach or site to be selected, resulting in schedule delays and a higher cost alternative.

## **BASIS OF ESTIMATE**

Project Name	<b>West Point Treatment Plant Nitrogen Removal - Alternative 2B</b>		
Project Number:		Date:	March 05, 2020

### **11.0 Contingency**

---

Contingency is a cost element of the estimate used to cover uncertainties and unforeseeable elements of cost within the defined project scope. Contingency covers inadequacies in project scope definition, estimating methods, and estimating data. Contingency specifically excludes changes in project scope, and unforeseen major events such as earthquakes, prolonged labor strikes, etc.

A 30% Project Contingency was added to the base estimate of Total Project Costs (direct and indirect) as a result of the project estimating process and in accordance with the King County WTD project delivery process.

The estimating analysis resulted in a project contingency of approximately \$665.98 million (US\$).

The total project cost at a 50% confidence level (P50) is typically used for funding and baselining of a project at this stage and level of engineering and project development. The P50 confidence level suggests that there is a 50% cumulative probability of project cost under-run (or 50% probability of exceedance) at this dollar amount for the presently defined and known project scope.

### **12.0 Management Reserve**

---

No allocation of costs was included in this estimate for Management Reserves.

Contingency is not intended to cover the costs for changes in project scope. If the project needs to provide an allowance for anticipated changes in scope or to cover the costs for items that may be required but have not yet been specifically identified as being included in the current project scope, then that amount of cost should be identified here.

### **13.0 Reconciliation**

---

Reconciliation was not conducted at this time.

### **14.0 Benchmarking**

---

All included Allied Costs as supplied by the PRISM historical database have been benchmarked against a similar portfolio of recently completed projects.

### **15.0 Estimate Quality Assurance Plan**

---

No reviews of total project costs have been conducted outside the reviews conducted within Brown and Caldwell and VMS estimating team. It is anticipated that upon completion of this estimate, reviews will happen between the estimate provider and WTD.

### **16.0 Attachments**

---

#### **Attachment: Estimate Deliverables**

Engineering and Estimating Deliverables provided include:

- West Point Treatment Process, King County WTD
- Scope Questions to Brown Caldwell – answered 10.17.19

## BASIS OF ESTIMATE

Project Name	<b>West Point Treatment Plant Nitrogen Removal - Alternative 2B</b>		
Project Number:		Date:	March 05, 2020

- Brown & Caldwell Markup, Existing HPO Retrofit Assumptions for MLE (Alt 2A/2B/3A/4A/4C)
- Brown & Caldwell Markup, Existing HPO Retrofit Assumptions for 4SMB (Alt 2C/3D/4D/4E)
- Brown & Caldwell Markup, Existing HPO Aerator Demo
- Brown & Caldwell Markup, Existing Secondary Clarifier Demo (Alt 2A/2B/2C)
- Brown & Caldwell Markup, Existing RAS Pumps Demo (Alt 2A/2B/2C/3A/3D)
- Brown & Caldwell Markup, Existing Liquid Oxygen Tanks Demo (All Alt. except Alt 1)
- Brown & Caldwell Markup, Existing Oxygen Generation Facility Demo (All Alt except Alt 1)
- WPTP Nitrogen Removal Study, Layout Flow Paths, Brown and Caldwell, All Alternatives
- WPTP Nitrogen Removal Study, All Layouts, Brown and Caldwell, All Alternatives
- Anammox Equipment, Budgetary Price, Brown and Caldwell, All Alternatives
- BW Reference Drawings, Brown & Caldwell, dated: 10.20.2006
- WPTP, Cost Estimating Assumptions, Brown & Caldwell, version 0
- Aeration Basin Mechanical Drawings Package, King County WTD, dated: 1991
- Aeration Basin Structural Drawings, King County WTD, dated: 1991
- WPTP, Drawing Location Numbers, King County WTD, dated: 04.26.2018
- WPTP, Facility Plan, King County WTD, dated: 07.2017
- WPTP, Oxygen Generation Bldg. Drawings, King County WTD, dated: 1992
- WPTP, Perspective Overview, King County WTD, dated: 02.24.2017
- WPTP, Secondary Clarifiers Drawings, King County WTD, dated: 1991
- WPTP, Yard Piping Drawings (1,2,3), King County WTD, dated: 1996

### Equipment Quotes:

- Aeration Blowers, Equipment Quotation, Next Turbo, dated: 09.27.19
- MBR, Equipment Quotation, Suez, dated: 10.01.19
- PE Screens, Equipment Quotation, Huber Technology, dated: 10.02.19
- Sidestream Anammox, Equipment Quotation, Ovivo, dated: 09.06.19



# King County

Department of Natural Resources and Parks  
Wastewater Treatment Division

## Project Planning and Delivery Section

### BASIS OF ESTIMATE

---

Project Name	<b>West Point Treatment Plant Nitrogen Removal - Alternative 2C</b>
Project Number	
Date Prepared	March 05, 2020
Requested by	Tiffany Knapp, King County WTD
Prepared by	Douglas W. Leo, CCP, CEP, FRICS, FAACE Hon. Life, (VMS, Inc.)
Estimate Classification	WTD Class 5
Estimate Purpose	King County Class 5 Concept Screening
Estimate ID (Version)	7
Project Manager	Eron Jacobson, King County WTD
Project Control Engineer	
Cc or Distribution List	

*Note that the accuracy of the associated cost estimate is dependent upon the various underlying assumptions, inclusions, and exclusions described herein. Actual project costs may differ and can be significantly affected by factors such as changes in the external environment, the manner in which the project is executed and controlled, and other factors that may impact the estimate basis or otherwise affect the project. Estimate accuracy ranges are only assessments based upon the cost estimating methods and data employed in preparing the estimate and are not a guarantee of actual project costs.*

## BASIS OF ESTIMATE

Project Name	<b>West Point Treatment Plant Nitrogen Removal - Alternative 2C</b>		
Project Number:		Date:	March 05, 2020

### 1.0 Purpose

---

The purpose of this estimate is to provide cost information to support King County's West Point Treatment Plant (WPTP) Flows and Loading Alternative Evaluation for the Nitrogen Removal Project. A series of alternatives have been developed for project evaluation to determine the best engineering and project cost solution.

This estimate was prepared to establish a King County Wastewater Treatment Division (WTD) pre-Class 5 conceptual cost estimate to provide order of magnitude cost to support WTD's capital project identification and budgeting process for Total Project Costs. The WTD pre-Class 5 estimate provides similar documentation to that of an AACE International Class 5 estimate. The range of anticipated project costs, per WTD estimating guidance, is -50% / +300%. The range of uncertainty is beyond that for a typical Class 5 estimate due to the scope being proximally defined with today's relative solutions and technologies to resolving the identified needs; when the projects move forward into capital delivery over the longer term, it is anticipated that many differences and changes may arise as the known and defined engineering solutions are developed.

Douglas Leo of Value Management Strategies, Inc. (VMS) prepared this Basis of Estimate in coordination with King County WTD, the Brown and Caldwell Engineers team, and the VMS estimating team after receiving scope information from WTD in October 2019 through March 2020. This Basis of Estimate reflects VMS's best understanding of the estimating process for this project, as explained by King County WTD and Brown and Caldwell.

### 2.0 Project Scope Definition

---

This estimate includes all investigation, administration/owners' costs, engineering and design, purchases, fabrications, installations, process certifications, permitting, community impacts, and miscellaneous costs not specifically excluded elsewhere in this document.

Comprehensive Total Field Costs are generated from historical allowances, sources such as WTD estimating tools, historical costs, and RS Means/VMS estimating databases. All supporting indirect costs were generated from the WTD PRISM historical database. All costs included in the estimate reflect the best understanding of requirements as they existed at the time this estimate was prepared.

The scope of Alternative 2C is to provide year-round nitrogen removal (4SMB/MBR and Sidestream Anammox) and the lowest effluent TIN possible while maintain the existing secondary treatment capacity. The scope was developed to a Conceptual Design level adequate to assess operations and maintenance issues, energy impacts, permitting and code compliance issues, constructability, and estimated costs.

The Project Estimate was prepared utilizing the following Work Breakdown Structure (WBS) in order to provide clarity and transparency to the estimated costs. The scope as identified for the alternative is described below in accordance with the WBS. Details are based on the known and defined scope in the design documents provided. See section 3.0 for a detailed list of Design Documents.

- A. Primary Effluent (PE)
  - New Drum Screens – purchase and install
  - PE Fine Screening Facility - 11,700 square feet.
  - Demolish Clarifier 12 and 13
  - Contractor Permit Fees at 1.0% Direct Costs
- B. Aeration Basins
  - General
    - Demolish Existing Aerators

## BASIS OF ESTIMATE

Project Name	<b>West Point Treatment Plant Nitrogen Removal - Alternative 2C</b>		
Project Number:		Date:	March 05, 2020

- New Aeration Basin Trains – purchase and install
  - Aeration Basin Interior Walls
  - Baffle Walls in Existing Aeration Basins – purchase and install
  - Aeration Basin Retention Wall – purchase and install
  - Contractor Permit Fees at 1.0% Direct Costs
- C. Membrane Basins
- Membrane System – purchase and install
  - MBR Bridge Crane and Rails
  - Concrete Membrane Vault Basins – purchase and install
  - Membrane Vault Basin Interior Walls
  - Contractor Permit Fees at 1.0% Direct Costs
- D. Internal Mixed Liquor Return (IMLR) Pumping
- IMLR Pump
  - 60" CS Pipe per Aeration Basin
  - Contractor Permit Fees at 1.0% Direct Costs
- E. Return Activated Sludge (RAS) Pump
- North RAS Pump Station Building – 2,317 square feet.
  - South RAS Pump Station Building – 4,362 square feet.
  - Demolish RAS Pumps and Clarifiers
  - Contractor Permit Fees at 1.0% Direct Costs
- F. Sidestream Anammox
- Sidestream Anammox – purchase and install
  - Pumps / Skimmer / Chain / Flight for Sedimentation Tank / Mixers – purchase and install
  - Centrate EQ Tank (80,000-gal) – purchase and install
  - Centrate Sedimentation Tank (151,000-gal) – purchase and install
  - Anammox Reactor Tanks (375,000-gal) – purchase and install
  - Contractor Permit Fees at 1.0% Direct Costs
- G. Supplemental Methanol System
- Supplemental Methanol 45,000-gallon System – purchase and install
  - Contractor Permit Fees at 1.0% Direct Costs
- H. Supplemental Alkalinity System
- Supplemental Alkalinity 60,000-gallon System – purchase and install
  - Contractor Permit Fees at 1.0% Direct Costs
- I. Aeration Blowers
- Aeration Blowers – purchase and install
  - Aeration Blower Diffusers – purchase and install
  - Demolition Allowance
  - Contractor Permit Fees at 1.0% Direct Costs
- J. Aeration Basin Mixers
- Aeration Basin Mixers – purchase and install
  - Contractor Permit Fees at 1.0% Direct Costs
- K. Sidestream Bioaugmentation
- *Not included in the scope for this alternative.*



## BASIS OF ESTIMATE

Project Name	<b>West Point Treatment Plant Nitrogen Removal - Alternative 2C</b>		
Project Number:		Date:	March 05, 2020

- L. Tertiary Pumps
  - *Not included in the scope for this alternative.*
- M. Tertiary Fixed Film System
  - *Not included in the scope for this alternative.*
- N. Aeration / MBR Odor Control
  - *Not included in the scope for this alternative.*
- O. Primary Clarifier / Aerated Grit Tank
  - *Not included in the scope for this alternative.*
- P. Miscellaneous Scope
  - Parking Garage to Accommodate 30 Spaces
  - Allowance for Electrical Power Upgrades
  - Temporary Dock
  - Large Crane at Loading Dock
  - Barge Charges with Tug
  - RAS Channel to Aeration Basins
  - Methanol Piping
  - Aeration Air to Aeration Basin
  - 132-inch RCP Pipe Extension, Valves and Controls – purchase and install
  - PE Pipe
  - Centrate to Anammox
  - Archeological Services
  - Site mitigation
  - Tribal Agreements
  - Contractor Permit Fees at 1.0% Direct Costs

### 3.0 Design Basis

---

This is an AACE International Class 5 estimate with all required documentation. The estimate is based on engineering deliverables, scoping documentation, discussions with the project team, and all supporting information and documentation provided in October 2019 through March 2020.

Engineering conceptual scope was provided in the following estimating deliverables. These are the most complete scoping documents that were available to the estimating provider.

Engineering and Estimating Deliverables provided include:

- West Point Treatment Process, King County WTD
- Scope Questions to Brown Caldwell – answered 10.17.19
- Brown & Caldwell Markup, Existing HPO Retrofit Assumptions for MLE (Alt 2A/2B/3A/4A/4C)
- Brown & Caldwell Markup, Existing HPO Retrofit Assumptions for 4SMB (Alt 2C/3D/4D/4E)
- Brown & Caldwell Markup, Existing HPO Aerator Demo
- Brown & Caldwell Markup, Existing Secondary Clarifier Demo (Alt 2A/2B/2C)
- Brown & Caldwell Markup, Existing RAS Pumps Demo (Alt 2A/2B/2C/3A/3D)
- Brown & Caldwell Markup, Existing Liquid Oxygen Tanks Demo (All Alt. except Alt 1)
- Brown & Caldwell Markup, Existing Oxygen Generation Facility Demo (All Alt except Alt 1)
- WPTP Nitrogen Removal Study, Layout Flow Paths, Brown and Caldwell, All Alternatives
- WPTP Nitrogen Removal Study, All Layouts, Brown and Caldwell, All Alternatives

## BASIS OF ESTIMATE

Project Name	<b>West Point Treatment Plant Nitrogen Removal - Alternative 2C</b>		
Project Number:		Date:	March 05, 2020

- Anammox Equipment, Budgetary Price, Brown and Caldwell, All Alternatives
- BW Reference Drawings, Brown & Caldwell, dated: 10.20.2006
- WPTP, Cost Estimating Assumptions, Brown & Caldwell, version 0
- Aeration Basin Mechanical Drawings Package, King County WTD, dated: 1991
- Aeration Basin Structural Drawings, King County WTD, dated: 1991
- WPTP, Drawing Location Numbers, King County WTD, dated: 04.26.2018
- WPTP, Facility Plan, King County WTD, dated: 07.2017
- WPTP, Oxygen Generation Bldg. Drawings, King County WTD, dated: 1992
- WPTP, Perspective Overview, King County WTD, dated: 02.24.2017
- WPTP, Secondary Clarifiers Drawings, King County WTD, dated: 1991
- WPTP, Yard Piping Drawings (1,2,3), King County WTD, dated: 1996

### Equipment Quotes:

- Aeration Blowers, Equipment Quotation, Next Turbo, dated: 09.27.19
- MBR, Equipment Quotation, Suez, dated: 10.01.19
- PE Screens, Equipment Quotation, Huber Technology, dated: 10.02.19
- Sidestream Anammox, Equipment Quotation, Ovivo, dated: 09.06.19

## 4.0 Planning Basis

---

The following planning basis assumptions were made for the project estimate:

- No project construction plan is in place at this time.
- The assumed execution strategy is a standard workweek with limited overtime.
- No unusual site conditions have been considered as part of this estimate.
- Adequate available power exists at the site.

## 5.0 Cost Basis

---

- All allied and indirect project costs (allowances for indeterminates, change order allowance, engineering, permitting, WTD staffing, etc.) have been estimated using WTD's PRISM cost model which is baselined to historical project costs.
- The estimate was performed based on drawings, sketches, and project information provided by King County and Brown and Caldwell Engineers.
- WTD is using a PRISM cost model dated January 26, 2017. All Allied and indirect project costs have been estimated using the new WTD PRISM cost model baselined to historical project costs.
- Additional technical project complexity factors for WTD indirect project costs have been introduced and incorporated into project allied costs to allow for development of an additional WTD indirect cost allowance, based upon the unique characteristics of the project.
- Equipment factors were developed utilizing historical data which accounts for specific install of the identified equipment within a normal battery limit. Specific scope relative to this project was used in the equipment factor determination. Factors for each specific type of equipment reflect the different complexity of the installation. Engineering supplied equipment costs were multiplied by the factors in order to estimate direct construction cost for the purchase and install of the equipment.

## BASIS OF ESTIMATE

Project Name	<b>West Point Treatment Plant Nitrogen Removal - Alternative 2C</b>		
Project Number:		Date:	March 05, 2020

- Estimated costs incorporate prevailing King County wage rates.
- All costs were estimated in 1<sup>st</sup> quarter 2020 dollars.

### 6.0 Allowances

---

The level and types of allowances used in the estimate is as follows (common percentages for each alternative are shown and any estimate-specific differences are indicated):

- Sales Tax was included as 10.1% applied to the base construction cost, including the design and change order contingencies.
- A 25% Allowance for Indeterminates (AFI) is applied to the base construction cost. The AFI is an allowance that accounts for the cost of known but undefined requirements necessary for a complete and workable project. The AFI accounts for elements that are not explicitly shown in the project documents to be further defined as part of the design development and project delivery process. The AFI is carried at 25% at conceptual design, based on the WTD project delivery process.
- Allowance of 10% for potential construction change orders.
- Allowance of 0.2% of the primary construction amount for miscellaneous direct capital costs.
- Allowance of 1.5% of the primary construction amount for permitting and other agency support.
- Allowance of 1.8% of the primary construction amount for miscellaneous services and material.
- Allowance of 0.65% of the primary construction amount for Non-WTD Support.
- Allowance of 1.0% of the primary construction amount for art initiatives.
- Allowance of 0.5% of the total project cost for sustainability.
- Allowance of 18.29% of the primary construction amount for Engineering Design Services.
- Allowance of 6.71% of the primary construction amount for Construction Management Services.
- Allowance of 16.33% of the primary construction amount for WTD Staff.
- Allowance of 1% of Directs Costs was included for Contractor Permit Fees.
- Allowance for application of total project contingency (see *Contingency* section below).
- Allowance of 0% was included for Escalation as the estimate is produced in current year (2020) dollars.
- Additional estimating allowances for WTD indirect costs of approximately \$249.86 million have been included in the Total Project Cost estimate by using a moderate degree of complexity rating for Project Controls and a high degree of complexity rating for all other indirect costs. Complexity factors were calibrated based on comments received from King County on March 4, 2020.
  - An allowance of \$163.24 million for Design and Construction Consulting
  - An allowance of \$13.84 million for Permitting & Other Agency Support
  - An allowance of \$72.77 million for WTD Staff Labor

## **BASIS OF ESTIMATE**

Project Name	<b>West Point Treatment Plant Nitrogen Removal - Alternative 2C</b>		
Project Number:		Date:	March 05, 2020

### **7.0 Assumptions**

---

Any other assumptions made by the estimator but not documented elsewhere in the estimate basis are included in this section.

- All costs included in the estimate reflect the best understanding of requirements as they existed at the time the estimates were prepared. Any modifications to the present scope and/or location of the project site may have substantial cost and schedule impacts.
- The engineering design will be performed by an external consultant engineer.
- Construction management will not be performed “in-house” by WTD. It will be performed by an external consultant construction manager.
- The project will generally align with the WTD PRISM cost model for Treatment projects.
- All work will always be performed utilizing safe work methods.
- Work will be sequenced to minimize standard process, service and community interruptions. However, no costs are included to address sequencing necessary keep the plant operational during construction.
- No costs are included for any new facilities that would be required, beyond the scope of this project to replace any lost capacity to the WPTP.
- It is assumed that the best improvement solution is included in the project scope(s).
- There will be some degree of productivity loss due to the site location. Some degree of productivity loss is included in the estimated costs. Any unusual site conditions are not accounted for in this estimate.
- Any additional work discovered during project implementation would need to be either a supplemental approval of added scope or be approved as an additional project.
- This project will be engineered to meet Washington State area seismic requirements.
- A degree of minimal cost rounding will occur during the normal estimating process.
- No allowance is included for Material Pricing Uncertainty.
- Power is readily available in the general area of this project. No new power sources are included in the scope of this project.
- It is assumed that some general material contamination is present. The estimate covers minimal cost of removal wherever the contamination is disturbed during construction. This cost is covered in productivity rates utilized in the estimate.
- It is assumed that the scope only requires 2” dia. methanol piping instead of any concrete channel structure.

### **8.0 Exclusions**

---

All potential items of cost which might be associated with the project but for which no costs have been included are listed below:

- No asbestos removal costs are included.
- No estimated costs are included for any potential delays due to interferences.

## **BASIS OF ESTIMATE**

Project Name	<b>West Point Treatment Plant Nitrogen Removal - Alternative 2C</b>		
Project Number:		Date:	March 05, 2020

- No costs are included for utility relocations.
- No costs are included for temporary construction easements.
- No costs are included for street use or street improvement permits.
- No costs are included for additional scope beyond that as detailed in the current scope of work.

### **9.0 Exceptions**

---

This estimate is classified as a King County Wastewater Treatment Division Class 5 estimate based on an AACE International Class 5 estimate, with no exceptions per the King County WTD project process, for the scope as known at the time of the estimate preparation.

### **10.0 Risks (Threats and Opportunities)**

---

At the time of estimate preparation, a formal risk analysis session had not been conducted. General potential risks are listed below.

- There is a risk that additional scope, technology advances or major deviation from the suggested project scope will adversely impact cost and schedule.
- Future unknown or changing site conditions present a risk around productivities, schedule, and costs.
- More stringent or completely new regulations, usage fees, permitting, or environmental impacts may result in risks that could adversely impact cost and schedule.
- Potential complex construction and constructability issues could arise during construction, resulting in major design/construction changes.
- The space constraints could significantly impact assumed productivities and crew sizes identified for the estimated concept, resulting in increased costs due to loss of production.
- The scheduled timing of project execution will greatly impact the bottom-line costs. There is risk related to labor availability and fluctuating commodity and equipment pricing in the timeframe between this early conceptual estimate and the actual execution of the project. Rising costs due to inflation, escalation and competing major worldwide projects pose the possibility of noticeable project cost and schedule increases.
- Weather conditions and emergency service interruptions present the possibility of negative schedule and cost impacts.
- Any possible coordination with other agencies could result in potential impacts on costs, schedule and Project Definition process.
- There is a risk that stakeholders could oppose the proposed design or prefer a different approach or site to be selected, resulting in schedule delays and a higher cost alternative.

## **BASIS OF ESTIMATE**

Project Name	<b>West Point Treatment Plant Nitrogen Removal - Alternative 2C</b>		
Project Number:		Date:	March 05, 2020

### **11.0 Contingency**

---

Contingency is a cost element of the estimate used to cover uncertainties and unforeseeable elements of cost within the defined project scope. Contingency covers inadequacies in project scope definition, estimating methods, and estimating data. Contingency specifically excludes changes in project scope, and unforeseen major events such as earthquakes, prolonged labor strikes, etc.

A 30% Project Contingency was added to the base estimate of Total Project Costs (direct and indirect) as a result of the project estimating process and in accordance with the King County WTD project delivery process.

The estimating analysis resulted in a project contingency of approximately \$657.35 million (US\$).

The total project cost at a 50% confidence level (P50) is typically used for funding and baselining of a project at this stage and level of engineering and project development. The P50 confidence level suggests that there is a 50% cumulative probability of project cost under-run (or 50% probability of exceedance) at this dollar amount for the presently defined and known project scope.

### **12.0 Management Reserve**

---

No allocation of costs was included in this estimate for Management Reserves.

Contingency is not intended to cover the costs for changes in project scope. If the project needs to provide an allowance for anticipated changes in scope or to cover the costs for items that may be required but have not yet been specifically identified as being included in the current project scope, then that amount of cost should be identified here.

### **13.0 Reconciliation**

---

Reconciliation was not conducted at this time.

### **14.0 Benchmarking**

---

All included Allied Costs as supplied by the PRISM historical database have been benchmarked against a similar portfolio of recently completed projects.

### **15.0 Estimate Quality Assurance Plan**

---

No reviews of total project costs have been conducted outside the reviews conducted within Brown and Caldwell and VMS estimating team. It is anticipated that upon completion of this estimate, reviews will happen between the estimate provider and WTD.

### **16.0 Attachments**

---

#### **Attachment: Estimate Deliverables**

Engineering and Estimating Deliverables provided include:

- West Point Treatment Process, King County WTD
- Scope Questions to Brown Caldwell – answered 10.17.19



## BASIS OF ESTIMATE

Project Name	<b>West Point Treatment Plant Nitrogen Removal - Alternative 2C</b>		
Project Number:		Date:	March 05, 2020

- Brown & Caldwell Markup, Existing HPO Retrofit Assumptions for MLE (Alt 2A/2B/3A/4A/4C)
- Brown & Caldwell Markup, Existing HPO Retrofit Assumptions for 4SMB (Alt 2C/3D/4D/4E)
- Brown & Caldwell Markup, Existing HPO Aerator Demo
- Brown & Caldwell Markup, Existing Secondary Clarifier Demo (Alt 2A/2B/2C)
- Brown & Caldwell Markup, Existing RAS Pumps Demo (Alt 2A/2B/2C/3A/3D)
- Brown & Caldwell Markup, Existing Liquid Oxygen Tanks Demo (All Alt. except Alt 1)
- Brown & Caldwell Markup, Existing Oxygen Generation Facility Demo (All Alt except Alt 1)
- WPTP Nitrogen Removal Study, Layout Flow Paths, Brown and Caldwell, All Alternatives
- WPTP Nitrogen Removal Study, All Layouts, Brown and Caldwell, All Alternatives
- Anammox Equipment, Budgetary Price, Brown and Caldwell, All Alternatives
- BW Reference Drawings, Brown & Caldwell, dated: 10.20.2006
- WPTP, Cost Estimating Assumptions, Brown & Caldwell, version 0
- Aeration Basin Mechanical Drawings Package, King County WTD, dated: 1991
- Aeration Basin Structural Drawings, King County WTD, dated: 1991
- WPTP, Drawing Location Numbers, King County WTD, dated: 04.26.2018
- WPTP, Facility Plan, King County WTD, dated: 07.2017
- WPTP, Oxygen Generation Bldg. Drawings, King County WTD, dated: 1992
- WPTP, Perspective Overview, King County WTD, dated: 02.24.2017
- WPTP, Secondary Clarifiers Drawings, King County WTD, dated: 1991
- WPTP, Yard Piping Drawings (1,2,3), King County WTD, dated: 1996

### Equipment Quotes:

- Aeration Blowers, Equipment Quotation, Next Turbo, dated: 09.27.19
- MBR, Equipment Quotation, Suez, dated: 10.01.19
- PE Screens, Equipment Quotation, Huber Technology, dated: 10.02.19
- Sidestream Anammox, Equipment Quotation, Ovivo, dated: 09.06.19



# King County

Department of Natural Resources and Parks  
Wastewater Treatment Division

## Project Planning and Delivery Section

### BASIS OF ESTIMATE

---

Project Name	<b>West Point Treatment Plant Nitrogen Removal - Alternative 3A</b>
Project Number	
Date Prepared	March 05, 2020
Requested by	Tiffany Knapp, King County WTD
Prepared by	Douglas W. Leo, CCP, CEP, FRICS, FAACE Hon. Life, (VMS, Inc.)
Estimate Classification	WTD Class 5
Estimate Purpose	King County Class 5 Concept Screening
Estimate ID (Version)	7
Project Manager	Eron Jacobson, King County WTD
Project Control Engineer	
Cc or Distribution List	

*Note that the accuracy of the associated cost estimate is dependent upon the various underlying assumptions, inclusions, and exclusions described herein. Actual project costs may differ and can be significantly affected by factors such as changes in the external environment, the manner in which the project is executed and controlled, and other factors that may impact the estimate basis or otherwise affect the project. Estimate accuracy ranges are only assessments based upon the cost estimating methods and data employed in preparing the estimate and are not a guarantee of actual project costs.*

## BASIS OF ESTIMATE

Project Name	<b>West Point Treatment Plant Nitrogen Removal - Alternative 3A</b>		
Project Number:		Date:	March 05, 2020

### 1.0 Purpose

---

The purpose of this estimate is to provide cost information to support King County's West Point Treatment Plant (WPTP) Flows and Loading Alternative Evaluation for the Nitrogen Removal Project. A series of alternatives have been developed for project evaluation to determine the best engineering and project cost solution.

This estimate was prepared to establish a King County Wastewater Treatment Division (WTD) pre-Class 5 conceptual cost estimate to provide order of magnitude cost to support WTD's capital project identification and budgeting process for Total Project Costs. The WTD pre-Class 5 estimate provides similar documentation to that of an AACE International Class 5 estimate. The range of anticipated project costs, per WTD estimating guidance, is -50% / +300%. The range of uncertainty is beyond that for a typical Class 5 estimate due to the scope being proximally defined with today's relative solutions and technologies to resolving the identified needs; when the projects move forward into capital delivery over the longer term, it is anticipated that many differences and changes may arise as the known and defined engineering solutions are developed.

Douglas Leo of Value Management Strategies, Inc. (VMS) prepared this Basis of Estimate in coordination with King County WTD, the Brown and Caldwell Engineers team, and the VMS estimating team after receiving scope information from WTD in October 2019 through March 2020. This Basis of Estimate reflects VMS's best understanding of the estimating process for this project, as explained by King County WTD and Brown and Caldwell.

### 2.0 Project Scope Definition

---

This estimate includes all investigation, administration/owners' costs, engineering and design, purchases, fabrications, installations, process certifications, permitting, community impacts, and miscellaneous costs not specifically excluded elsewhere in this document.

Comprehensive Total Field Costs are generated from historical allowances, sources such as WTD estimating tools, historical costs, and RS Means/VMS estimating databases. All supporting indirect costs were generated from the WTD PRISM historical database. All costs included in the estimate reflect the best understanding of requirements as they existed at the time this estimate was prepared.

The scope of Alternative 3A is to provide seasonal nitrogen removal (MLE/MBR and Sidestream Anammox) and the lowest effluent TIN possible while maintain the existing secondary treatment capacity. The scope was developed to a Conceptual Design level adequate to assess operations and maintenance issues, energy impacts, permitting and code compliance issues, constructability, and estimated costs.

The Project Estimate was prepared utilizing the following Work Breakdown Structure (WBS) in order to provide clarity and transparency to the estimated costs. The scope as identified for the alternative is described below in accordance with the WBS. Details are based on the known and defined scope in the design documents provided. See section 3.0 for a detailed list of Design Documents.

- A. Primary Effluent (PE)
  - New Drum Screens – purchase and install
  - PE Fine Screening Facility - 11,700 square feet.
  - Demolish Clarifier 11, 12 and 13
  - Contractor Permit Fees at 1.0% Direct Costs
- B. Aeration Basins
  - General
    - Demolish Existing Aerators

## BASIS OF ESTIMATE

Project Name	<b>West Point Treatment Plant Nitrogen Removal - Alternative 3A</b>		
Project Number:		Date:	March 05, 2020

- New Aeration Basin Trains – purchase and install
  - Aeration Basin Interior Wall
  - Aeration Basin Retention Wall – purchase and install
  - Contractor Permit Fees at 1.0% Direct Costs
- C. Membrane Basins
- Membrane System – purchase and install
  - MBR Bridge Crane and Rail
  - Concrete Membrane Vault Basins – purchase and install
  - Membrane Vault Basin Interior Walls
  - Contractor Permit Fees at 1.0% Direct Costs
- D. Internal Mixed Liquor Return (IMLR) Pumping
- IMLR Pump
  - 60" CS Pipe per Aeration Basin
  - Contractor Permit Fees at 1.0% Direct Costs
- E. Return Activated Sludge (RAS) Pump
- North RAS Pump Station Building – 2317 square feet
  - South RAS Pump Station Building – 4362 square feet
  - Demolish RAS Pumps and Clarifiers
  - Contractor Permit Fees at 1.0% Direct Costs
- F. Sidestream Anammox
- Sidestream Anammox – purchase and install
  - Pumps / Skimmer / Chain / Flight for Sedimentation Tank / Mixers – purchase and install
  - Centrate EQ Tank (80,000-gal) – purchase and install
  - Centrate Sedimentation Tank (151,000-gal) – purchase and install
  - Anammox Reactor Tanks (375,000-gal) – purchase and install
  - Contractor Permit Fees at 1.0% Direct Costs
- G. Supplemental Methanol System
- Supplemental Methanol 30,000-gallon System – purchase and install
  - Contractor Permit Fees at 1.0% Direct Costs
- H. Supplemental Alkalinity System
- Supplemental Alkalinity 45,000-gallon System – purchase and install
  - Contractor Permit Fees at 1.0% Direct Costs
- I. Aeration Blowers
- Aeration Blowers – purchase and install
  - Aeration Blower Diffusers – purchase and install
  - Demolition Allowance
  - Contractor Permit Fees at 1.0% Direct Costs
- J. Aeration Basin Mixers for Anoxic Zones
- Aeration Basin Mixers – purchase and install
  - Contractor Permit Fees at 1.0% Direct Costs
- K. Sidestream Bioaugmentation
- *Not included in the scope for this alternative.*
- L. Tertiary Pumps

## BASIS OF ESTIMATE

Project Name	<b>West Point Treatment Plant Nitrogen Removal - Alternative 3A</b>		
Project Number:		Date:	March 05, 2020

- *Not included in the scope for this alternative.*
- M. Tertiary Fixed Film System
  - *Not included in the scope for this alternative.*
- N. Aeration / MBR Odor Control
  - *Not included in the scope for this alternative.*
- O. Primary Clarifier / Aerated Grit Tank
  - *Not included in the scope for this alternative.*
- P. Miscellaneous Scope
  - Parking Garage to Accommodate 30 Spaces
  - Temporary Dock
  - Large Crane at Loading Dock
  - Barge Charges with Tug
  - RAS Channel to Aeration Basins
  - Methanol Piping
  - 54" Aeration Air to Aeration Basin
  - 132-inch RCP Pipe Extension, Valves and Controls – purchase and install
  - PE Pipe
  - Centrate to Anammox
  - Archeological Services
  - Site mitigation
  - Tribal Agreements
  - Contractor Permit Fees at 1.0% Direct Costs

### 3.0 Design Basis

---

This is an AACE International Class 5 estimate with all required documentation. The estimate is based on engineering deliverables, scoping documentation, discussions with the project team, and all supporting information and documentation provided in October 2019 through March 2020.

Engineering conceptual scope was provided in the following estimating deliverables. These are the most complete scoping documents that were available to the estimating provider.

Engineering and Estimating Deliverables provided include:

- West Point Treatment Process, King County WTD
- Scope Questions to Brown Caldwell – answered 10.17.19
- Brown & Caldwell Markup, Existing HPO Retrofit Assumptions for MLE (Alt 2A/2B/3A/4A/4C)
- Brown & Caldwell Markup, Existing HPO Retrofit Assumptions for 4SMB (Alt 2C/3D/4D/4E)
- Brown & Caldwell Markup, Existing HPO Aerator Demo
- Brown & Caldwell Markup, Existing Secondary Clarifier Demo (Alt 2A/2B/2C)
- Brown & Caldwell Markup, Existing Secondary Clarifier Demo (Alt3A/3D)
- Brown & Caldwell Markup, Existing RAS Pumps Demo (Alt 2A/2B/2C/3A/3D)
- Brown & Caldwell Markup, Existing Liquid Oxygen Tanks Demo (All Alt. except Alt 1)
- Brown & Caldwell Markup, Existing Oxygen Generation Facility Demo (All Alt except Alt 1)
- WPTP Nitrogen Removal Study, Layout Flow Paths, Brown and Caldwell, All Alternatives
- WPTP Nitrogen Removal Study, All Layouts, Brown and Caldwell, All Alternatives

## BASIS OF ESTIMATE

Project Name	<b>West Point Treatment Plant Nitrogen Removal - Alternative 3A</b>		
Project Number:		Date:	March 05, 2020

- Anammox Equipment, Budgetary Price, Brown and Caldwell, All Alternatives
- BW Reference Drawings, Brown & Caldwell, dated: 10.20.2006
- WPTP, Cost Estimating Assumptions, Brown & Caldwell, version 0
- Aeration Basin Mechanical Drawings Package, King County WTD, dated: 1991
- Aeration Basin Structural Drawings, King County WTD, dated: 1991
- WPTP, Drawing Location Numbers, King County WTD, dated: 04.26.2018
- WPTP, Facility Plan, King County WTD, dated: 07.2017
- WPTP, Oxygen Generation Bldg. Drawings, King County WTD, dated: 1992
- WPTP, Perspective Overview, King County WTD, dated: 02.24.2017
- WPTP, Secondary Clarifiers Drawings, King County WTD, dated: 1991
- WPTP, Yard Piping Drawings (1,2,3), King County WTD, dated: 1996

### Equipment Quotes:

- Aeration Blowers, Equipment Quotation, Next Turbo, dated: 09.27.19
- MBR, Equipment Quotation, Suez, dated: 10.01.19
- PE Screens, Equipment Quotation, Huber Technology, dated: 10.02.19
- Sidestream Anammox, Equipment Quotation, Ovivo, dated: 09.06.19

## 4.0 Planning Basis

---

The following planning basis assumptions were made for the project estimate:

- No project construction plan is in place at this time.
- The assumed execution strategy is a standard workweek with limited overtime.
- No unusual site conditions have been considered as part of this estimate.
- Adequate available power exists at the site.

## 5.0 Cost Basis

---

- All allied and indirect project costs (allowances for indeterminates, change order allowance, engineering, permitting, WTD staffing, etc.) have been estimated using WTD's PRISM cost model which is baselined to historical project costs.
- The estimate was performed based on drawings, sketches, and project information provided by King County and Brown and Caldwell Engineers.
- WTD is using a PRISM cost model dated January 26, 2017. All Allied and indirect project costs have been estimated using the new WTD PRISM cost model baselined to historical project costs.
- Additional technical project complexity factors for WTD indirect project costs have been introduced and incorporated into project allied costs to allow for development of an additional WTD indirect cost allowance, based upon the unique characteristics of the project.
- Equipment factors were developed utilizing historical data which accounts for specific install of the identified equipment within a normal battery limit. Specific scope relative to this project was used in the equipment factor determination. Factors for each specific type of equipment reflect the different complexity of the installation. Engineering supplied equipment costs were multiplied

## BASIS OF ESTIMATE

Project Name	<b>West Point Treatment Plant Nitrogen Removal - Alternative 3A</b>		
Project Number:		Date:	March 05, 2020

by the factors in order to estimate direct construction cost for the purchase and install of the equipment.

- Estimated costs incorporate prevailing King County wage rates.
- All costs were estimated in 1<sup>st</sup> quarter 2020 dollars.

### 6.0 Allowances

---

The level and types of allowances used in the estimate is as follows (common percentages for each alternative are shown and any estimate-specific differences are indicated):

- Sales Tax was included as 10.1% applied to the base construction cost, including the design and change order contingencies.
- A 25% Allowance for Indeterminates (AFI) is applied to the base construction cost. The AFI is an allowance that accounts for the cost of known but undefined requirements necessary for a complete and workable project. The AFI accounts for elements that are not explicitly shown in the project documents to be further defined as part of the design development and project delivery process. The AFI is carried at 25% at conceptual design, based on the WTD project delivery process.
- Allowance of 10% for potential construction change orders.
- Allowance of 0.2% of the primary construction amount for miscellaneous direct capital costs.
- Allowance of 1.5% of the primary construction amount for permitting and other agency support.
- Allowance of 1.8% of the primary construction amount for miscellaneous services and material.
- Allowance of 0.65% of the primary construction amount for Non-WTD Support.
- Allowance of 1.0% of the primary construction amount for art initiatives.
- Allowance of 0.5% of the total project cost for sustainability.
- Allowance of 19.89% of the primary construction amount for Engineering Design Services.
- Allowance of 7.53% of the primary construction amount for Construction Management Services.
- Allowance of 15.57% of the primary construction amount for WTD Staff.
- Allowance of 1% of Directs Costs was included for Contractor Permit Fees.
- Allowance for application of total project contingency (see *Contingency* section below).
- Allowance of 0% was included for Escalation as the estimate is produced in current year (2020) dollars.
- Additional estimating allowances for WTD indirect costs of approximately \$150.81 million have been included in the Total Project Cost estimate by using a moderate degree of complexity rating for Community Relations, Environmental Planning and Management, Project Management, and Project Controls and a high degree of complexity rating for all other indirect costs. Complexity factors were calibrated based on comments received from King County on March 4, 2020.
  - An allowance of \$105.19 million for Design and Construction Consulting
  - An allowance of \$8.14 million for Permitting & Other Agency Support



## BASIS OF ESTIMATE

Project Name	<b>West Point Treatment Plant Nitrogen Removal - Alternative 3A</b>		
Project Number:		Date:	March 05, 2020

- An allowance of \$37.47 million for WTD Staff Labor

### 7.0 Assumptions

---

Any other assumptions made by the estimator but not documented elsewhere in the estimate basis are included in this section.

- All costs included in the estimate reflect the best understanding of requirements as they existed at the time the estimates were prepared. Any modifications to the present scope and/or location of the project site may have substantial cost and schedule impacts.
- The engineering design will be performed by an external consultant engineer.
- Construction management will not be performed “in-house” by WTD. It will be performed by an external consultant construction manager.
- The project will generally align with the WTD PRISM cost model for Treatment projects.
- All work will always be performed utilizing safe work methods.
- Work will be sequenced to minimize standard process, service and community interruptions. However, no costs are included to address sequencing necessary keep the plant operational during construction.
- No costs are included for any new facilities that would be required, beyond the scope of this project to replace any lost capacity to the WPTP.
- It is assumed that the best improvement solution is included in the project scope(s).
- There will be some degree of productivity loss due to the site location. Some degree of productivity loss is included in the estimated costs. Any unusual site conditions are not accounted for in this estimate.
- Any additional work discovered during project implementation would need to be either a supplemental approval of added scope or be approved as an additional project.
- This project will be engineered to meet Washington State area seismic requirements.
- A degree of minimal cost rounding will occur during the normal estimating process.
- No allowance is included for Material Pricing Uncertainty.
- Power is readily available in the general area of this project. No new power sources are included in the scope of this project.
- It is assumed that some general material contamination is present. The estimate covers minimal cost of removal wherever the contamination is disturbed during construction. This cost is covered in productivity rates utilized in the estimate.
- It is assumed that the scope only requires 2” dia. methanol piping instead of any concrete channel structure.

### 8.0 Exclusions

---

All potential items of cost which might be associated with the project but for which no costs have been included are listed below:

## BASIS OF ESTIMATE

Project Name	<b>West Point Treatment Plant Nitrogen Removal - Alternative 3A</b>		
Project Number:		Date:	March 05, 2020

- No asbestos removal costs are included.
- No estimated costs are included for any potential delays due to interferences.
- No costs are included for utility relocations.
- No costs are included for temporary construction easements.
- No costs are included for street use or street improvement permits.
- No costs are included for additional scope beyond that as detailed in the current scope of work.

### 9.0 Exceptions

---

This estimate is classified as a King County Wastewater Treatment Division Class 5 estimate based on an AACE International Class 5 estimate, with no exceptions per the King County WTD project process, for the scope as known at the time of the estimate preparation.

### 10.0 Risks (Threats and Opportunities)

---

At the time of estimate preparation, a formal risk analysis session had not been conducted. General potential risks are listed below.

- There is a risk that additional scope, technology advances or major deviation from the suggested project scope will adversely impact cost and schedule.
- Future unknown or changing site conditions present a risk around productivities, schedule, and costs.
- More stringent or completely new regulations, usage fees, permitting, or environmental impacts may result in risks that could adversely impact cost and schedule.
- Potential complex construction and constructability issues could arise during construction, resulting in major design/construction changes.
- The space constraints could significantly impact assumed productivities and crew sizes identified for the estimated concept, resulting in increased costs due to loss of production.
- The scheduled timing of project execution will greatly impact the bottom-line costs. There is risk related to labor availability and fluctuating commodity and equipment pricing in the timeframe between this early conceptual estimate and the actual execution of the project. Rising costs due to inflation, escalation and competing major worldwide projects pose the possibility of noticeable project cost and schedule increases.
- Weather conditions and emergency service interruptions present the possibility of negative schedule and cost impacts.
- Any possible coordination with other agencies could result in potential impacts on costs, schedule and Project Definition process.
- There is a risk that stakeholders could oppose the proposed design or prefer a different approach or site to be selected, resulting in schedule delays and a higher cost alternative.

## **BASIS OF ESTIMATE**

Project Name	<b>West Point Treatment Plant Nitrogen Removal - Alternative 3A</b>		
Project Number:		Date:	March 05, 2020

### **11.0 Contingency**

---

Contingency is a cost element of the estimate used to cover uncertainties and unforeseeable elements of cost within the defined project scope. Contingency covers inadequacies in project scope definition, estimating methods, and estimating data. Contingency specifically excludes changes in project scope, and unforeseen major events such as earthquakes, prolonged labor strikes, etc.

A 30% Project Contingency was added to the base estimate of Total Project Costs (direct and indirect) as a result of the project estimating process and in accordance with the King County WTD project delivery process.

The estimating analysis resulted in a project contingency of approximately \$390.68 million (US\$).

The total project cost at a 50% confidence level (P50) is typically used for funding and baselining of a project at this stage and level of engineering and project development. The P50 confidence level suggests that there is a 50% cumulative probability of project cost under-run (or 50% probability of exceedance) at this dollar amount for the presently defined and known project scope.

### **12.0 Management Reserve**

---

No allocation of costs was included in this estimate for Management Reserves.

Contingency is not intended to cover the costs for changes in project scope. If the project needs to provide an allowance for anticipated changes in scope or to cover the costs for items that may be required but have not yet been specifically identified as being included in the current project scope, then that amount of cost should be identified here.

### **13.0 Reconciliation**

---

Reconciliation was not conducted at this time.

### **14.0 Benchmarking**

---

All included Allied Costs as supplied by the PRISM historical database have been benchmarked against a similar portfolio of recently completed projects.

### **15.0 Estimate Quality Assurance Plan**

---

No reviews of total project costs have been conducted outside the reviews conducted within Brown and Caldwell and VMS estimating team. It is anticipated that upon completion of this estimate, reviews will happen between the estimate provider and WTD.

### **16.0 Attachments**

---

#### **Attachment: Estimate Deliverables**

Engineering and Estimating Deliverables provided include:

- West Point Treatment Process, King County WTD
- Scope Questions to Brown Caldwell – answered 10.17.19

## BASIS OF ESTIMATE

Project Name	<b>West Point Treatment Plant Nitrogen Removal - Alternative 3A</b>		
Project Number:		Date:	March 05, 2020

- Brown & Caldwell Markup, Existing HPO Retrofit Assumptions for MLE (Alt 2A/2B/3A/4A/4C)
- Brown & Caldwell Markup, Existing HPO Retrofit Assumptions for 4SMB (Alt 2C/3D/4D/4E)
- Brown & Caldwell Markup, Existing HPO Aerator Demo
- Brown & Caldwell Markup, Existing Secondary Clarifier Demo (Alt 2A/2B/2C)
- Brown & Caldwell Markup, Existing Secondary Clarifier Demo (Alt3A/3D)
- Brown & Caldwell Markup, Existing RAS Pumps Demo (Alt 2A/2B/2C/3A/3D)
- Brown & Caldwell Markup, Existing Liquid Oxygen Tanks Demo (All Alt. except Alt 1)
- Brown & Caldwell Markup, Existing Oxygen Generation Facility Demo (All Alt except Alt 1)
- WPTP Nitrogen Removal Study, Layout Flow Paths, Brown and Caldwell, All Alternatives
- WPTP Nitrogen Removal Study, All Layouts, Brown and Caldwell, All Alternatives
- Anammox Equipment, Budgetary Price, Brown and Caldwell, All Alternatives
- BW Reference Drawings, Brown & Caldwell, dated: 10.20.2006
- WPTP, Cost Estimating Assumptions, Brown & Caldwell, version 0
- Aeration Basin Mechanical Drawings Package, King County WTD, dated: 1991
- Aeration Basin Structural Drawings, King County WTD, dated: 1991
- WPTP, Drawing Location Numbers, King County WTD, dated: 04.26.2018
- WPTP, Facility Plan, King County WTD, dated: 07.2017
- WPTP, Oxygen Generation Bldg. Drawings, King County WTD, dated: 1992
- WPTP, Perspective Overview, King County WTD, dated: 02.24.2017
- WPTP, Secondary Clarifiers Drawings, King County WTD, dated: 1991
- WPTP, Yard Piping Drawings (1,2,3), King County WTD, dated: 1996

### Equipment Quotes:

- Aeration Blowers, Equipment Quotation, Next Turbo, dated: 09.27.19
- MBR, Equipment Quotation, Suez, dated: 10.01.19
- PE Screens, Equipment Quotation, Huber Technology, dated: 10.02.19
- Sidestream Anammox, Equipment Quotation, Ovivo, dated: 09.06.19



# King County

Department of Natural Resources and Parks  
Wastewater Treatment Division

## Project Planning and Delivery Section

### BASIS OF ESTIMATE

---

Project Name	<b>West Point Treatment Plant Nitrogen Removal - Alternative 3D</b>
Project Number	
Date Prepared	March 5, 2020
Requested by	Tiffany Knapp, King County WTD
Prepared by	Douglas W. Leo, CCP, CEP, FRICS, FAACE Hon. Life, (VMS, Inc.)
Estimate Classification	WTD Class 5
Estimate Purpose	King County Class 5 Concept Screening
Estimate ID (Version)	7
Project Manager	Eron Jacobson, King County WTD
Project Control Engineer	
Cc or Distribution List	

*Note that the accuracy of the associated cost estimate is dependent upon the various underlying assumptions, inclusions, and exclusions described herein. Actual project costs may differ and can be significantly affected by factors such as changes in the external environment, the manner in which the project is executed and controlled, and other factors that may impact the estimate basis or otherwise affect the project. Estimate accuracy ranges are only assessments based upon the cost estimating methods and data employed in preparing the estimate and are not a guarantee of actual project costs.*

## BASIS OF ESTIMATE

Project Name	<b>West Point Treatment Plant Nitrogen Removal - Alternative 3D</b>		
Project Number:		Date:	March 5, 2020

### 1.0 Purpose

---

The purpose of this estimate is to provide cost information to support King County's West Point Treatment Plant (WPTP) Flows and Loading Alternative Evaluation for the Nitrogen Removal Project. A series of alternatives have been developed for project evaluation to determine the best engineering and project cost solution.

This estimate was prepared to establish a King County Wastewater Treatment Division (WTD) pre-Class 5 conceptual cost estimate to provide order of magnitude cost to support WTD's capital project identification and budgeting process for Total Project Costs. The WTD pre-Class 5 estimate provides similar documentation to that of an AACE International Class 5 estimate. The range of anticipated project costs, per WTD estimating guidance, is -50% / +300%. The range of uncertainty is beyond that for a typical Class 5 estimate due to the scope being proximally defined with today's relative solutions and technologies to resolving the identified needs; when the projects move forward into capital delivery over the longer term, it is anticipated that many differences and changes may arise as the known and defined engineering solutions are developed.

Douglas Leo of Value Management Strategies, Inc. (VMS) prepared this Basis of Estimate in coordination with King County WTD, the Brown and Caldwell Engineers team, and the VMS estimating team after receiving scope information from WTD in October 2019 through March 2020. This Basis of Estimate reflects VMS's best understanding of the estimating process for this project, as explained by King County WTD and Brown and Caldwell.

### 2.0 Project Scope Definition

---

This estimate includes all investigation, administration/owners' costs, engineering and design, purchases, fabrications, installations, process certifications, permitting, community impacts, and miscellaneous costs not specifically excluded elsewhere in this document.

Comprehensive Total Field Costs are generated from historical allowances, sources such as WTD estimating tools, historical costs, and RS Means/VMS estimating databases. All supporting indirect costs were generated from the WTD PRISM historical database. All costs included in the estimate reflect the best understanding of requirements as they existed at the time this estimate was prepared.

The scope of Alternative 3D is to provide seasonal nitrogen removal (4SMB/MBR and Sidestream Anammox) and the lowest effluent TIN possible while maintain the existing secondary treatment capacity. The scope was developed to a Conceptual Design level adequate to assess operations and maintenance issues, energy impacts, permitting and code compliance issues, constructability, and estimated costs.

The Project Estimate was prepared utilizing the following Work Breakdown Structure (WBS) in order to provide clarity and transparency to the estimated costs. The scope as identified for the alternative is described below in accordance with the WBS. Details are based on the known and defined scope in the design documents provided. See section 3.0 for a detailed list of Design Documents.

- A. Primary Effluent (PE)
  - New Drum Screens – purchase and install
  - PE Fine Screening Facility - 11,700 square feet
  - Demolish Clarifier 11, 12 and 13
  - Contractor Permit Fees at 1.0% Direct Costs
- B. Aeration Basins
  - General
    - Demo Existing Aerators
    - New Aeration Basin Trains – purchase and install

## BASIS OF ESTIMATE

Project Name	<b>West Point Treatment Plant Nitrogen Removal - Alternative 3D</b>		
Project Number:		Date:	March 5, 2020

- Aeration Basin Interior walls
  - Baffle Walls in Existing Aeration Basins – purchase and install
  - Aeration Basin Retention Wall – purchase and install
  - Contractor Permit Fees at 1.0% Direct Costs
- C. Membrane Basins
- Membrane System – purchase and install
  - MBR Bridge Crane and Rail
  - Concrete Membrane Vault Basins – purchase and install
  - Membrane Vault Basin Interior Walls
  - Contractor Permit Fees at 1.0% Direct Costs
- D. Internal Mixed Liquor Return (IMLR) Pumping
- IMLR Pump
  - 60" CS Pipe per Aeration Basin
  - Contractor Permit Fees at 1.0% Direct Costs
- E. Return Activated Sludge (RAS) Pump
- North RAS Pump Station Building – 2317 square feet
  - South RAS Pump Station Building – 4362 square feet
  - Demolish RAS Pumps and Clarifiers
  - Contractor Permit Fees at 1.0% Direct Costs
- F. Sidestream Anammox
- Sidestream Anammox – purchase and install
  - Pumps / Skimmer / Chain / Flight for Sedimentation Tank / Mixers – purchase and install
  - Centrate EQ Tank (80,000-gal) – purchase and install
  - Centrate Sedimentation Tank (151,000-gal) – purchase and install
  - Anammox Reactor Tanks (375,000-gal) – purchase and install
  - Contractor Permit Fees at 1.0% Direct Costs
- G. Supplemental Methanol System
- Supplemental Methanol 30,000-gallon System – purchase and install
  - Contractor Permit Fees at 1.0% Direct Costs
- H. Supplemental Alkalinity System
- Supplemental Alkalinity 45,000-gallon System – purchase and install
  - Contractor Permit Fees at 1.0% Direct Costs
- I. Aeration Blowers
- Aeration Blowers – purchase and install
  - Aeration Blower Diffusers– purchase and install
  - Demolition Allowance
  - Contractor Permit Fees at 1.0% Direct Costs
- J. Aeration Basin Mixers
- Aeration Basin Mixers – purchase and install
  - Contractor Permit Fees at 1.0% Direct Costs
- K. Sidestream Bioaugmentation
- *Not included in the scope for this alternative.*
- L. Tertiary Pumps



## BASIS OF ESTIMATE

Project Name	<b>West Point Treatment Plant Nitrogen Removal - Alternative 3D</b>		
Project Number:		Date:	March 5, 2020

- *Not included in the scope for this alternative.*
- M. Tertiary Fixed Film System
  - *Not included in the scope for this alternative.*
- N. Aeration / MBR Odor Control
  - *Not included in the scope for this alternative.*
- O. Primary Clarifier / Aerated Grit Tank
  - *Not included in the scope for this alternative.*
- P. Miscellaneous Scope
  - Parking Garage to Accommodate 30 Spaces
  - Temporary Dock
  - Large Crane at Loading Dock
  - Barge Charges with Tug
  - RAS Channel to Aeration Basins
  - Methanol Piping
  - 48" Aeration Air to Aeration Basin
  - 132-inch RCP Pipe Extension, Valves and Controls – purchase and install
  - PE Pipe
  - Centrate to Anammox
  - Archeological Services
  - Site mitigation
  - Tribal Agreements
  - Contractor Permit Fees at 1.0% Direct Costs

### 3.0 Design Basis

---

This is an AACE International Class 5 estimate with all required documentation. The estimate is based on engineering deliverables, scoping documentation, discussions with the project team, and all supporting information and documentation provided in October 2019 through March 2020.

Engineering conceptual scope was provided in the following estimating deliverables. These are the most complete scoping documents that were available to the estimating provider.

Engineering and Estimating Deliverables provided include:

- West Point Treatment Process, King County WTD
- Scope Questions to Brown Caldwell – answered 10.17.19
- Brown & Caldwell Markup, Existing HPO Retrofit Assumptions for MLE (Alt 2A/2B/3A/4A/4C)
- Brown & Caldwell Markup, Existing HPO Retrofit Assumptions for 4SMB (Alt 2C/3D/4D/4E)
- Brown & Caldwell Markup, Existing HPO Aerator Demo
- Brown & Caldwell Markup, Existing Secondary Clarifier Demo (Alt 2A/2B/2C)
- Brown & Caldwell Markup, Existing Secondary Clarifier Demo (Alt3A/3D)
- Brown & Caldwell Markup, Existing RAS Pumps Demo (Alt 2A/2B/2C/3A/3D)
- Brown & Caldwell Markup, Existing Liquid Oxygen Tanks Demo (All Alt. except Alt 1)
- Brown & Caldwell Markup, Existing Oxygen Generation Facility Demo (All Alt except Alt 1)
- WPTP Nitrogen Removal Study, Layout Flow Paths, Brown and Caldwell, All Alternatives
- WPTP Nitrogen Removal Study, All Layouts, Brown and Caldwell, All Alternatives

## BASIS OF ESTIMATE

Project Name	<b>West Point Treatment Plant Nitrogen Removal - Alternative 3D</b>		
Project Number:		Date:	March 5, 2020

- Anammox Equipment, Budgetary Price, Brown and Caldwell, All Alternatives
- BW Reference Drawings, Brown & Caldwell, dated: 10.20.2006
- WPTP, Cost Estimating Assumptions, Brown & Caldwell, version 0
- Aeration Basin Mechanical Drawings Package, King County WTD, dated: 1991
- Aeration Basin Structural Drawings, King County WTD, dated: 1991
- WPTP, Drawing Location Numbers, King County WTD, dated: 04.26.2018
- WPTP, Facility Plan, King County WTD, dated: 07.2017
- WPTP, Oxygen Generation Bldg. Drawings, King County WTD, dated: 1992
- WPTP, Perspective Overview, King County WTD, dated: 02.24.2017
- WPTP, Secondary Clarifiers Drawings, King County WTD, dated: 1991
- WPTP, Yard Piping Drawings (1,2,3), King County WTD, dated: 1996

### Equipment Quotes:

- Aeration Blowers, Equipment Quotation, Next Turbo, dated: 09.27.19
- MBR, Equipment Quotation, Suez, dated: 10.01.19
- PE Screens, Equipment Quotation, Huber Technology, dated: 10.02.19
- Sidestream Anammox, Equipment Quotation, Ovivo, dated: 09.06.19

## 4.0 Planning Basis

---

The following planning basis assumptions were made for the project estimate:

- No project construction plan is in place at this time.
- The assumed execution strategy is a standard workweek with limited overtime.
- No unusual site conditions have been considered as part of this estimate.
- Adequate available power exists at the site.

## 5.0 Cost Basis

---

- All allied and indirect project costs (allowances for indeterminates, change order allowance, engineering, permitting, WTD staffing, etc.) have been estimated using WTD's PRISM cost model which is baselined to historical project costs.
- The estimate was performed based on drawings, sketches, and project information provided by King County and Brown and Caldwell Engineers.
- WTD is using a PRISM cost model dated January 26, 2017. All Allied and indirect project costs have been estimated using the new WTD PRISM cost model baselined to historical project costs.
- Additional technical project complexity factors for WTD indirect project costs have been introduced and incorporated into project allied costs to allow for development of an additional WTD indirect cost allowance, based upon the unique characteristics of the project.
- Equipment factors were developed utilizing historical data which accounts for specific install of the identified equipment within a normal battery limit. Specific scope relative to this project was used in the equipment factor determination. Factors for each specific type of equipment reflect the different complexity of the installation. Engineering supplied equipment costs were multiplied

## BASIS OF ESTIMATE

Project Name	<b>West Point Treatment Plant Nitrogen Removal - Alternative 3D</b>		
Project Number:		Date:	March 5, 2020

by the factors in order to estimate direct construction cost for the purchase and install of the equipment.

- Estimated costs incorporate prevailing King County wage rates.
- All costs were estimated in 1<sup>st</sup> quarter 2020 dollars.

### 6.0 Allowances

---

The level and types of allowances used in the estimate is as follows (common percentages for each alternative are shown and any estimate-specific differences are indicated):

- Sales Tax was included as 10.1% applied to the base construction cost, including the design and change order contingencies.
- A 25% Allowance for Indeterminates (AFI) is applied to the base construction cost. The AFI is an allowance that accounts for the cost of known but undefined requirements necessary for a complete and workable project. The AFI accounts for elements that are not explicitly shown in the project documents to be further defined as part of the design development and project delivery process. The AFI is carried at 25% at conceptual design, based on the WTD project delivery process.
- Allowance of 10% for potential construction change orders.
- Allowance of 0.2% of the primary construction amount for miscellaneous direct capital costs.
- Allowance of 1.5% of the primary construction amount for permitting and other agency support.
- Allowance of 1.8% of the primary construction amount for miscellaneous services and material.
- Allowance of 0.65% of the primary construction amount for Non-WTD Support.
- Allowance of 1.0% of the primary construction amount for art initiatives.
- Allowance of 0.5% of the total project cost for sustainability.
- Allowance of 19.89% of the primary construction amount for Engineering Design Services.
- Allowance of 7.53% of the primary construction amount for Construction Management Services.
- Allowance of 15.56% of the primary construction amount for WTD Staff.
- Allowance of 1% of Directs Costs was included for Contractor Permit Fees.
- Allowance for application of total project contingency (see *Contingency* section below).
- Allowance of 0% was included for Escalation as the estimate is produced in current year (2020) dollars.
- Additional estimating allowances for WTD indirect costs of approximately \$151.12 million have been included in the Total Project Cost estimate by using a moderate degree of complexity rating for Community Relations, Environmental Planning and Management, Project Management, and Project Controls and a high degree of complexity rating for all other indirect costs. Complexity factors were calibrated based on comments received from King County on March 4, 2020.
  - An allowance of \$105.39 million for Design and Construction Consulting
  - An allowance of \$8.16 million for Permitting & Other Agency Support

## BASIS OF ESTIMATE

Project Name	<b>West Point Treatment Plant Nitrogen Removal - Alternative 3D</b>		
Project Number:		Date:	March 5, 2020

- An allowance of \$37.56 million for WTD Staff Labor

### 7.0 Assumptions

---

Any other assumptions made by the estimator but not documented elsewhere in the estimate basis are included in this section.

- All costs included in the estimate reflect the best understanding of requirements as they existed at the time the estimates were prepared. Any modifications to the present scope and/or location of the project site may have substantial cost and schedule impacts.
- The engineering design will be performed by an external consultant engineer.
- Construction management will not be performed “in-house” by WTD. It will be performed by an external consultant construction manager.
- The project will generally align with the WTD PRISM cost model for Treatment projects.
- All work will always be performed utilizing safe work methods.
- Work will be sequenced to minimize standard process, service and community interruptions. However, no costs are included to address sequencing necessary keep the plant operational during construction.
- No costs are included for any new facilities that would be required, beyond the scope of this project to replace any lost capacity to the WPTP.
- It is assumed that the best improvement solution is included in the project scope(s).
- There will be some degree of productivity loss due to the site location. Some degree of productivity loss is included in the estimated costs. Any unusual site conditions are not accounted for in this estimate.
- Any additional work discovered during project implementation would need to be either a supplemental approval of added scope or be approved as an additional project.
- This project will be engineered to meet Washington State area seismic requirements.
- A degree of minimal cost rounding will occur during the normal estimating process.
- No allowance is included for Material Pricing Uncertainty.
- Power is readily available in the general area of this project. No new power sources are included in the scope of this project.
- It is assumed that some general material contamination is present. The estimate covers minimal cost of removal wherever the contamination is disturbed during construction. This cost is covered in productivity rates utilized in the estimate.
- It is assumed that the scope only requires 2” dia. methanol piping instead of any concrete channel structure.

### 8.0 Exclusions

---

All potential items of cost which might be associated with the project but for which no costs have been included are listed below:

## BASIS OF ESTIMATE

Project Name	<b>West Point Treatment Plant Nitrogen Removal - Alternative 3D</b>		
Project Number:		Date:	March 5, 2020

- No asbestos removal costs are included.
- No estimated costs are included for any potential delays due to interferences.
- No costs are included for utility relocations.
- No costs are included for temporary construction easements.
- No costs are included for street use or street improvement permits.
- No costs are included for additional scope beyond that as detailed in the current scope of work.

### 9.0 Exceptions

---

This estimate is classified as a King County Wastewater Treatment Division Class 5 estimate based on an AACE International Class 5 estimate, with no exceptions per the King County WTD project process, for the scope as known at the time of the estimate preparation.

### 10.0 Risks (Threats and Opportunities)

---

At the time of estimate preparation, a formal risk analysis session had not been conducted. General potential risks are listed below.

- There is a risk that additional scope, technology advances or major deviation from the suggested project scope will adversely impact cost and schedule.
- Future unknown or changing site conditions present a risk around productivities, schedule, and costs.
- More stringent or completely new regulations, usage fees, permitting, or environmental impacts may result in risks that could adversely impact cost and schedule.
- Potential complex construction and constructability issues could arise during construction, resulting in major design/construction changes.
- The space constraints could significantly impact assumed productivities and crew sizes identified for the estimated concept, resulting in increased costs due to loss of production.
- The scheduled timing of project execution will greatly impact the bottom-line costs. There is risk related to labor availability and fluctuating commodity and equipment pricing in the timeframe between this early conceptual estimate and the actual execution of the project. Rising costs due to inflation, escalation and competing major worldwide projects pose the possibility of noticeable project cost and schedule increases.
- Weather conditions and emergency service interruptions present the possibility of negative schedule and cost impacts.
- Any possible coordination with other agencies could result in potential impacts on costs, schedule and Project Definition process.
- There is a risk that stakeholders could oppose the proposed design or prefer a different approach or site to be selected, resulting in schedule delays and a higher cost alternative.

## **BASIS OF ESTIMATE**

Project Name	<b>West Point Treatment Plant Nitrogen Removal - Alternative 3D</b>		
Project Number:		Date:	March 5, 2020

### **11.0 Contingency**

---

Contingency is a cost element of the estimate used to cover uncertainties and unforeseeable elements of cost within the defined project scope. Contingency covers inadequacies in project scope definition, estimating methods, and estimating data. Contingency specifically excludes changes in project scope, and unforeseen major events such as earthquakes, prolonged labor strikes, etc.

A 30% Project Contingency was added to the base estimate of Total Project Costs (direct and indirect) as a result of the project estimating process and in accordance with the King County WTD project delivery process.

The estimating analysis resulted in a project contingency of approximately \$391.56 million (US\$).

The total project cost at a 50% confidence level (P50) is typically used for funding and baselining of a project at this stage and level of engineering and project development. The P50 confidence level suggests that there is a 50% cumulative probability of project cost under-run (or 50% probability of exceedance) at this dollar amount for the presently defined and known project scope.

### **12.0 Management Reserve**

---

No allocation of costs was included in this estimate for Management Reserves.

Contingency is not intended to cover the costs for changes in project scope. If the project needs to provide an allowance for anticipated changes in scope or to cover the costs for items that may be required but have not yet been specifically identified as being included in the current project scope, then that amount of cost should be identified here.

### **13.0 Reconciliation**

---

Reconciliation was not conducted at this time.

### **14.0 Benchmarking**

---

All included Allied Costs as supplied by the PRISM historical database have been benchmarked against a similar portfolio of recently completed projects.

### **15.0 Estimate Quality Assurance Plan**

---

No reviews of total project costs have been conducted outside the reviews conducted within Brown and Caldwell and VMS estimating team. It is anticipated that upon completion of this estimate, reviews will happen between the estimate provider and WTD.

### **16.0 Attachments**

---

#### **Attachment: Estimate Deliverables**

Engineering and Estimating Deliverables provided include:

- West Point Treatment Process, King County WTD
- Scope Questions to Brown Caldwell – answered 10.17.19

## BASIS OF ESTIMATE

Project Name	<b>West Point Treatment Plant Nitrogen Removal - Alternative 3D</b>		
Project Number:		Date:	March 5, 2020

- Brown & Caldwell Markup, Existing HPO Retrofit Assumptions for MLE (Alt 2A/2B/3A/4A/4C)
- Brown & Caldwell Markup, Existing HPO Retrofit Assumptions for 4SMB (Alt 2C/3D/4D/4E)
- Brown & Caldwell Markup, Existing HPO Aerator Demo
- Brown & Caldwell Markup, Existing Secondary Clarifier Demo (Alt 2A/2B/2C)
- Brown & Caldwell Markup, Existing Secondary Clarifier Demo (Alt3A/3D)
- Brown & Caldwell Markup, Existing RAS Pumps Demo (Alt 2A/2B/2C/3A/3D)
- Brown & Caldwell Markup, Existing Liquid Oxygen Tanks Demo (All Alt. except Alt 1)
- Brown & Caldwell Markup, Existing Oxygen Generation Facility Demo (All Alt except Alt 1)
- WPTP Nitrogen Removal Study, Layout Flow Paths, Brown and Caldwell, All Alternatives
- WPTP Nitrogen Removal Study, All Layouts, Brown and Caldwell, All Alternatives
- Anammox Equipment, Budgetary Price, Brown and Caldwell, All Alternatives
- BW Reference Drawings, Brown & Caldwell, dated: 10.20.2006
- WPTP, Cost Estimating Assumptions, Brown & Caldwell, version 0
- Aeration Basin Mechanical Drawings Package, King County WTD, dated: 1991
- Aeration Basin Structural Drawings, King County WTD, dated: 1991
- WPTP, Drawing Location Numbers, King County WTD, dated: 04.26.2018
- WPTP, Facility Plan, King County WTD, dated: 07.2017
- WPTP, Oxygen Generation Bldg. Drawings, King County WTD, dated: 1992
- WPTP, Perspective Overview, King County WTD, dated: 02.24.2017
- WPTP, Secondary Clarifiers Drawings, King County WTD, dated: 1991
- WPTP, Yard Piping Drawings (1,2,3), King County WTD, dated: 1996

### Equipment Quotes:

- Aeration Blowers, Equipment Quotation, Next Turbo, dated: 09.27.19
- MBR, Equipment Quotation, Suez, dated: 10.01.19
- PE Screens, Equipment Quotation, Huber Technology, dated: 10.02.19
- Sidestream Anammox, Equipment Quotation, Ovivo, dated: 09.06.19





# King County

Department of Natural Resources and Parks  
Wastewater Treatment Division

## Project Planning and Delivery Section

### BASIS OF ESTIMATE

---

Project Name	<b>West Point Treatment Plant Nitrogen Removal - Alternative 4A</b>
Project Number	
Date Prepared	March 05, 2020
Requested by	Tiffany Knapp, King County WTD
Prepared by	Douglas W. Leo, CCP, CEP, FRICS, FAACE Hon. Life, (VMS, Inc.)
Estimate Classification	WTD Class 5
Estimate Purpose	King County Class 5 Concept Screening
Estimate ID (Version)	7
Project Manager	Eron Jacobson, King County WTD
Project Control Engineer	
Cc or Distribution List	

*Note that the accuracy of the associated cost estimate is dependent upon the various underlying assumptions, inclusions, and exclusions described herein. Actual project costs may differ and can be significantly affected by factors such as changes in the external environment, the manner in which the project is executed and controlled, and other factors that may impact the estimate basis or otherwise affect the project. Estimate accuracy ranges are only assessments based upon the cost estimating methods and data employed in preparing the estimate and are not a guarantee of actual project costs.*

## BASIS OF ESTIMATE

Project Name	<b>West Point Treatment Plant Nitrogen Removal - Alternative 4A</b>		
Project Number:		Date:	March 05, 2020

### 1.0 Purpose

---

The purpose of this estimate is to provide cost information to support King County's West Point Treatment Plant (WPTP) Flows and Loading Alternative Evaluation for the Nitrogen Removal Project. A series of alternatives have been developed for project evaluation to determine the best engineering and project cost solution.

This estimate was prepared to establish a King County Wastewater Treatment Division (WTD) pre-Class 5 conceptual cost estimate to provide order of magnitude cost to support WTD's capital project identification and budgeting process for Total Project Costs. The WTD pre-Class 5 estimate provides similar documentation to that of an AACE International Class 5 estimate. The range of anticipated project costs, per WTD estimating guidance, is -50% / +300%. The range of uncertainty is beyond that for a typical Class 5 estimate due to the scope being proximally defined with today's relative solutions and technologies to resolving the identified needs; when the projects move forward into capital delivery over the longer term, it is anticipated that many differences and changes may arise as the known and defined engineering solutions are developed.

Douglas Leo of Value Management Strategies, Inc. (VMS) prepared this Basis of Estimate in coordination with King County WTD, the Brown and Caldwell Engineers team, and the VMS estimating team after receiving scope information from WTD in October 2019 through March 2020. This Basis of Estimate reflects VMS's best understanding of the estimating process for this project, as explained by King County WTD and Brown and Caldwell.

### 2.0 Project Scope Definition

---

This estimate includes all investigation, administration/owners' costs, engineering and design, purchases, fabrications, installations, process certifications, permitting, community impacts, and miscellaneous costs not specifically excluded elsewhere in this document.

Comprehensive Total Field Costs are generated from historical allowances, sources such as WTD estimating tools, historical costs, and RS Means/VMS estimating databases. All supporting indirect costs were generated from the WTD PRISM historical database. All costs included in the estimate reflect the best understanding of requirements as they existed at the time this estimate was prepared.

The scope of Alternative 4A is to provide year-round nitrogen removal (MLE) and an effluent TIN limit of 8mg/L with reduced secondary treatment capacity. The scope was developed to a Conceptual Design level adequate to assess operations and maintenance issues, energy impacts, permitting and code compliance issues, constructability, and estimated costs.

The Project Estimate was prepared utilizing the following Work Breakdown Structure (WBS) in order to provide clarity and transparency to the estimated costs. The scope as identified for the alternative is described below in accordance with the WBS. Details are based on the known and defined scope in the design documents provided. See section 3.0 for a detailed list of Design Documents.

- A. Primary Effluent (PE)
  - *Not included in the scope for this alternative.*
- B. Aeration Basins
  - General
    - Demolish Existing Aerators
    - Construct New Aeration Basin Trains – purchase and install
    - Aeration Basin Interior Walls
    - Aeration Basin Retention Wall – purchase and install

## BASIS OF ESTIMATE

Project Name	<b>West Point Treatment Plant Nitrogen Removal - Alternative 4A</b>		
Project Number:		Date:	March 05, 2020

- Contractor Permit Fees at 1.0% Direct Costs
- C. Membrane Basins
  - *Not included in the scope for this alternative.*
- D. Internal Mixed Liquor Return (IMLR) Pumping
  - IMLR Pump
  - 48" CS Pipe per Aeration Basin
  - Contractor Permit Fees at 1.0% Direct Costs
- E. Return Activated Sludge (RAS) Pump
  - Extend Piping From Existing Pumps to New Aeration Basins – purchase and install
  - Contractor Permit Fees at 1.0% Direct Costs
- F. Sidestream Anammox
  - *Not included in the scope for this alternative.*
- G. Supplemental Methanol System
  - Supplemental Methanol 15,000-gallon System – purchase and install
  - Contractor Permit Fees at 1.0% Direct Costs
- H. Supplemental Alkalinity System
  - Supplemental Alkalinity 45,000-gallon System – purchase and install
  - Contractor Permit Fees at 1.0% Direct Costs
- I. Aeration Blowers
  - Aeration Blowers – purchase and install
  - Aeration Blower Diffusers – purchase and install
  - Demolition Allowance
  - Contractor Permit Fees at 1.0% Direct Costs
- J. Aeration Basin Mixers
  - Aeration Basin Mixers – purchase and install
  - Contractor Permit Fees at 1.0% Direct Costs
- K. Sidestream Bioaugmentation
  - *Not included in the scope for this alternative.*
- L. Tertiary Pumps
  - *Not included in the scope for this alternative.*
- M. Tertiary Fixed Film System
  - *Not included in the scope for this alternative.*
- N. Aeration / MBR Odor Control
  - *Not included in the scope for this alternative.*
- O. Primary Clarifier / Aerated Grit Tank
  - *Not included in the scope for this alternative.*
- P. Miscellaneous Scope
  - Parking Garage to Accommodate 30 Spaces
  - Temporary Dock
  - Large Crane Loading Dock
  - Barge Charges with Tug
  - Methanol Piping

## BASIS OF ESTIMATE

Project Name	<b>West Point Treatment Plant Nitrogen Removal - Alternative 4A</b>		
Project Number:		Date:	March 05, 2020

- Aeration Air to Aeration Basin
- 132-inch RCP Pipe Extension, Valves and Controls – purchase and install
- PE Pipe
- Centrate to Anammox
- Archeological Services
- Site Mitigation
- Tribal Agreements
- Contractor Permit Fees at 1.0% Direct Costs

### 3.0 Design Basis

---

This is an AACE International Class 5 estimate with all required documentation. The estimate is based on engineering deliverables, scoping documentation, discussions with the project team, and all supporting information and documentation provided in October 2019 through March 2020.

Engineering conceptual scope was provided in the following estimating deliverables. These are the most complete scoping documents that were available to the estimating provider.

Engineering and Estimating Deliverables provided include:

- West Point Treatment Process, King County WTD
- Scope Questions to Brown Caldwell – answered 10.17.19
- Brown & Caldwell Markup, Existing HPO Retrofit Assumptions for MLE (Alt 2A/2B/3A/4A/4C)
- Brown & Caldwell Markup, Existing HPO Retrofit Assumptions for 4SMB (Alt 2C/3D/4D/4E)
- Brown & Caldwell Markup, Existing HPO Aerator Demo
- Brown & Caldwell Markup, Existing Secondary Clarifier Demo (Alt3A/3D)
- Brown & Caldwell Markup, Existing Liquid Oxygen Tanks Demo (All Alt. except Alt 1)
- Brown & Caldwell Markup, Existing Oxygen Generation Facility Demo (All Alt except Alt 1)
- WPTP Nitrogen Removal Study, Layout Flow Paths, Brown and Caldwell, All Alternatives
- WPTP Nitrogen Removal Study, All Layouts, Brown and Caldwell, All Alternatives
- Anammox Equipment, Budgetary Price, Brown and Caldwell, All Alternatives
- BW Reference Drawings, Brown & Caldwell, dated: 10.20.2006
- WPTP, Cost Estimating Assumptions, Brown & Caldwell, version 0
- Aeration Basin Mechanical Drawings Package, King County WTD, dated: 1991
- Aeration Basin Structural Drawings, King County WTD, dated: 1991
- WPTP, Drawing Location Numbers, King County WTD, dated: 04.26.2018
- WPTP, Facility Plan, King County WTD, dated: 07.2017
- WPTP, Oxygen Generation Bldg. Drawings, King County WTD, dated: 1992
- WPTP, Perspective Overview, King County WTD, dated: 02.24.2017
- WPTP, Secondary Clarifiers Drawings, King County WTD, dated: 1991
- WPTP, Yard Piping Drawings (1,2,3), King County WTD, dated: 1996

Equipment Quotes:

- Aeration Blowers, Equipment Quotation, Next Turbo, dated: 09.27.19
- MBR, Equipment Quotation, Suez, dated: 10.01.19
- PE Screens, Equipment Quotation, Huber Technology, dated: 10.02.19
- Sidestream Anammox, Equipment Quotation, Ovivo, dated: 09.06.19

## **BASIS OF ESTIMATE**

Project Name	<b>West Point Treatment Plant Nitrogen Removal - Alternative 4A</b>		
Project Number:		Date:	March 05, 2020

### **4.0 Planning Basis**

---

The following planning basis assumptions were made for the project estimate:

- No project construction plan is in place at this time.
- The assumed execution strategy is a standard workweek with limited overtime.
- No unusual site conditions have been considered as part of this estimate.
- Adequate available power exists at the site.

### **5.0 Cost Basis**

---

- All allied and indirect project costs (allowances for indeterminates, change order allowance, engineering, permitting, WTD staffing, etc.) have been estimated using WTD's PRISM cost model which is baselined to historical project costs.
- The estimate was performed based on drawings, sketches, and project information provided by King County and Brown and Caldwell Engineers.
- WTD is using a PRISM cost model dated January 26, 2017. All Allied and indirect project costs have been estimated using the new WTD PRISM cost model baselined to historical project costs.
- Additional technical project complexity factors for WTD indirect project costs have been introduced and incorporated into project allied costs to allow for development of an additional WTD indirect cost allowance, based upon the unique characteristics of the project.
- Equipment factors were developed utilizing historical data which accounts for specific install of the identified equipment within a normal battery limit. Specific scope relative to this project was used in the equipment factor determination. Factors for each specific type of equipment reflect the different complexity of the installation. Engineering supplied equipment costs were multiplied by the factors in order to estimate direct construction cost for the purchase and install of the equipment.
- Estimated costs incorporate prevailing King County wage rates.
- All costs were estimated in 1<sup>st</sup> quarter 2020 dollars.

### **6.0 Allowances**

---

The level and types of allowances used in the estimate is as follows (common percentages for each alternative are shown and any estimate-specific differences are indicated):

- Sales Tax was included as 10.1% applied to the base construction cost, including the design and change order contingencies.
- A 25% Allowance for Indeterminates (AFI) is applied to the base construction cost. The AFI is an allowance that accounts for the cost of known but undefined requirements necessary for a complete and workable project. The AFI accounts for elements that are not explicitly shown in the project documents to be further defined as part of the design development and project delivery process. The AFI is carried at 25% at conceptual design, based on the WTD project delivery process.

## BASIS OF ESTIMATE

Project Name	<b>West Point Treatment Plant Nitrogen Removal - Alternative 4A</b>		
Project Number:		Date:	March 05, 2020

- Allowance of 10% for potential construction change orders.
- Allowance of 0.2% of the primary construction amount for miscellaneous direct capital costs.
- Allowance of 1.5% of the primary construction amount for permitting and other agency support.
- Allowance of 1.8% of the primary construction amount for miscellaneous services and material.
- Allowance of 0.65% of the primary construction amount for Non-WTD Support.
- Allowance of 1.0% of the primary construction amount for art initiatives.
- Allowance of 0.5% of the total project cost for sustainability.
- Allowance of 0.5% of the total project cost for sustainability.
- Allowance of 16.18% of the primary construction amount for Engineering Design Services.
- Allowance of 8.42% of the primary construction amount for Construction Management Services.
- Allowance of 15.88% of the primary construction amount for WTD Staff.
- Allowance of 1% of Directs Costs was included for Contractor Permit Fees.
- Allowance for application of total project contingency (see *Contingency* section below).
- Allowance of 0% was included for Escalation as the estimate is produced in current year (2020) dollars.
- Additional estimating allowances for WTD indirect costs of approximately \$69.61 million have been included in the Total Project Cost estimate by using a moderate degree of complexity rating for Design Engineering, Community Relations, Environmental Planning and Management, Project Management, and Project Controls and a high degree of complexity rating for all other indirect costs. Complexity factors were calibrated based on comments received from King County on March 4, 2020.
  - An allowance of \$42.45 million for Design and Construction Consulting
  - An allowance of \$4.87 million for Permitting & Other Agency Support
  - An allowance of \$22.28 million for WTD Staff Labor

## 7.0 Assumptions

---

Any other assumptions made by the estimator but not documented elsewhere in the estimate basis are included in this section.

- All costs included in the estimate reflect the best understanding of requirements as they existed at the time the estimates were prepared. Any modifications to the present scope and/or location of the project site may have substantial cost and schedule impacts.
- The engineering design will be performed by an external consultant engineer.
- Construction management will not be performed ‘in-house’ by WTD. It will be performed by an external consultant construction manager.
- The project will generally align with the WTD PRISM cost model for Treatment projects.
- All work will always be performed utilizing safe work methods.

## BASIS OF ESTIMATE

Project Name	<b>West Point Treatment Plant Nitrogen Removal - Alternative 4A</b>		
Project Number:		Date:	March 05, 2020

- Work will be sequenced to minimize standard process, service and community interruptions. However, no costs are included to address sequencing necessary keep the plant operational during construction.
- No costs are included for any new facilities that would be required, beyond the scope of this project to replace any lost capacity to the WPTP.
- It is assumed that the best improvement solution is included in the project scope(s).
- There will be some degree of productivity loss due to the site location. Some degree of productivity loss is included in the estimated costs. Any unusual site conditions are not accounted for in this estimate.
- Any additional work discovered during project implementation would need to be either a supplemental approval of added scope or be approved as an additional project.
- This project will be engineered to meet Washington State area seismic requirements.
- A degree of minimal cost rounding will occur during the normal estimating process.
- No allowance is included for Material Pricing Uncertainty.
- Power is readily available in the general area of this project. No new power sources are included in the scope of this project.
- It is assumed that some general material contamination is present. The estimate covers minimal cost of removal wherever the contamination is disturbed during construction. This cost is covered in productivity rates utilized in the estimate.
- It is assumed that the scope only requires 2" dia. methanol piping instead of any concrete channel structure.

### 8.0 Exclusions

---

All potential items of cost which might be associated with the project but for which no costs have been included are listed below:

- No asbestos removal costs are included.
- No estimated costs are included for any potential delays due to interferences.
- No costs are included for utility relocations.
- No costs are included for temporary construction easements.
- No costs are included for street use or street improvement permits.
- No costs are included for additional scope beyond that as detailed in the current scope of work.

### 9.0 Exceptions

---

This estimate is classified as a King County Wastewater Treatment Division Class 5 estimate based on an ACE International Class 5 estimate, with no exceptions per the King County WTD project process, for the scope as known at the time of the estimate preparation.



## BASIS OF ESTIMATE

Project Name	<b>West Point Treatment Plant Nitrogen Removal - Alternative 4A</b>		
Project Number:		Date:	March 05, 2020

### 10.0 Risks (Threats and Opportunities)

---

At the time of estimate preparation, a formal risk analysis session had not been conducted. General potential risks are listed below.

- There is a risk that additional scope, technology advances or major deviation from the suggested project scope will adversely impact cost and schedule.
- Future unknown or changing site conditions present a risk around productivities, schedule, and costs.
- More stringent or completely new regulations, usage fees, permitting, or environmental impacts may result in risks that could adversely impact cost and schedule.
- Potential complex construction and constructability issues could arise during construction, resulting in major design/construction changes.
- The space constraints could significantly impact assumed productivities and crew sizes identified for the estimated concept, resulting in increased costs due to loss of production.
- The scheduled timing of project execution will greatly impact the bottom-line costs. There is risk related to labor availability and fluctuating commodity and equipment pricing in the timeframe between this early conceptual estimate and the actual execution of the project. Rising costs due to inflation, escalation and competing major worldwide projects pose the possibility of noticeable project cost and schedule increases.
- Weather conditions and emergency service interruptions present the possibility of negative schedule and cost impacts.
- Any possible coordination with other agencies could result in potential impacts on costs, schedule and Project Definition process.
- There is a risk that stakeholders could oppose the proposed design or prefer a different approach or site to be selected, resulting in schedule delays and a higher cost alternative.

### 11.0 Contingency

---

Contingency is a cost element of the estimate used to cover uncertainties and unforeseeable elements of cost within the defined project scope. Contingency covers inadequacies in project scope definition, estimating methods, and estimating data. Contingency specifically excludes changes in project scope, and unforeseen major events such as earthquakes, prolonged labor strikes, etc.

A 30% Project Contingency was added to the base estimate of Total Project Costs (direct and indirect) as a result of the project estimating process and in accordance with the King County WTD project delivery process.

The estimating analysis resulted in a project contingency of approximately \$230.12 million (US\$).

The total project cost at a 50% confidence level (P50) is typically used for funding and baselining of a project at this stage and level of engineering and project development. The P50 confidence level suggests that there is a 50% cumulative probability of project cost under-run (or 50% probability of exceedance) at this dollar amount for the presently defined and known project scope.

## **BASIS OF ESTIMATE**

Project Name	<b>West Point Treatment Plant Nitrogen Removal - Alternative 4A</b>		
Project Number:		Date:	March 05, 2020

### **12.0 Management Reserve**

---

No allocation of costs was included in this estimate for Management Reserves.

Contingency is not intended to cover the costs for changes in project scope. If the project needs to provide an allowance for anticipated changes in scope or to cover the costs for items that may be required but have not yet been specifically identified as being included in the current project scope, then that amount of cost should be identified here.

### **13.0 Reconciliation**

---

Reconciliation was not conducted at this time.

### **14.0 Benchmarking**

---

All included Allied Costs as supplied by the PRISM historical database have been benchmarked against a similar portfolio of recently completed projects.

### **15.0 Estimate Quality Assurance Plan**

---

No reviews of total project costs have been conducted outside the reviews conducted within Brown and Caldwell and VMS estimating team. It is anticipated that upon completion of this estimate, reviews will happen between the estimate provider and WTD.

### **16.0 Attachments**

---

#### **Attachment: Estimate Deliverables**

Engineering and Estimating Deliverables provided include:

- West Point Treatment Process, King County WTD
- Scope Questions to Brown Caldwell – answered 10.17.19
- Brown & Caldwell Markup, Existing HPO Retrofit Assumptions for MLE (Alt 2A/2B/3A/4A/4C)
- Brown & Caldwell Markup, Existing HPO Retrofit Assumptions for 4SMB (Alt 2C/3D/4D/4E)
- Brown & Caldwell Markup, Existing HPO Aerator Demo
- Brown & Caldwell Markup, Existing Secondary Clarifier Demo (Alt3A/3D)
- Brown & Caldwell Markup, Existing Liquid Oxygen Tanks Demo (All Alt. except Alt 1)
- Brown & Caldwell Markup, Existing Oxygen Generation Facility Demo (All Alt except Alt 1)
- WPTP Nitrogen Removal Study, Layout Flow Paths, Brown and Caldwell, All Alternatives
- WPTP Nitrogen Removal Study, All Layouts, Brown and Caldwell, All Alternatives
- Anammox Equipment, Budgetary Price, Brown and Caldwell, All Alternatives
- BW Reference Drawings, Brown & Caldwell, dated: 10.20.2006
- WPTP, Cost Estimating Assumptions, Brown & Caldwell, version 0
- Aeration Basin Mechanical Drawings Package, King County WTD, dated: 1991
- Aeration Basin Structural Drawings, King County WTD, dated: 1991
- WPTP, Drawing Location Numbers, King County WTD, dated: 04.26.2018
- WPTP, Facility Plan, King County WTD, dated: 07.2017
- WPTP, Oxygen Generation Bldg. Drawings, King County WTD, dated: 1992

## BASIS OF ESTIMATE

Project Name	<b>West Point Treatment Plant Nitrogen Removal - Alternative 4A</b>		
Project Number:		Date:	March 05, 2020

- WPTP, Perspective Overview, King County WTD, dated: 02.24.2017
- WPTP, Secondary Clarifiers Drawings, King County WTD, dated: 1991
- WPTP, Yard Piping Drawings (1,2,3), King County WTD, dated: 1996

### Equipment Quotes:

- Aeration Blowers, Equipment Quotation, Next Turbo, dated: 09.27.19
- MBR, Equipment Quotation, Suez, dated: 10.01.19
- PE Screens, Equipment Quotation, Huber Technology, dated: 10.02.19
- Sidestream Anammox, Equipment Quotation, Ovivo, dated: 09.06.19



# King County

Department of Natural Resources and Parks  
Wastewater Treatment Division

## Project Planning and Delivery Section

### BASIS OF ESTIMATE

---

Project Name	<b>West Point Treatment Plant Nitrogen Removal - Alternative 4C</b>
Project Number	
Date Prepared	March 05, 2020
Requested by	Tiffany Knapp, King County WTD
Prepared by	Douglas W. Leo, CCP, CEP, FRICS, FAACE Hon. Life, (VMS, Inc.)
Estimate Classification	WTD Class 5
Estimate Purpose	King County Class 5 Concept Screening
Estimate ID (Version)	7
Project Manager	Eron Jacobson, King County WTD
Project Control Engineer	
Cc or Distribution List	

*Note that the accuracy of the associated cost estimate is dependent upon the various underlying assumptions, inclusions, and exclusions described herein. Actual project costs may differ and can be significantly affected by factors such as changes in the external environment, the manner in which the project is executed and controlled, and other factors that may impact the estimate basis or otherwise affect the project. Estimate accuracy ranges are only assessments based upon the cost estimating methods and data employed in preparing the estimate and are not a guarantee of actual project costs.*

## BASIS OF ESTIMATE

Project Name	<b>West Point Treatment Plant Nitrogen Removal - Alternative 4C</b>		
Project Number:		Date:	March 05, 2020

### 1.0 Purpose

---

The purpose of this estimate is to provide cost information to support King County's West Point Treatment Plant (WPTP) Flows and Loading Alternative Evaluation for the Nitrogen Removal Project. A series of alternatives have been developed for project evaluation to determine the best engineering and project cost solution.

This estimate was prepared to establish a King County Wastewater Treatment Division (WTD) pre-Class 5 conceptual cost estimate to provide order of magnitude cost to support WTD's capital project identification and budgeting process for Total Project Costs. The WTD pre-Class 5 estimate provides similar documentation to that of an AACE International Class 5 estimate. The range of anticipated project costs, per WTD estimating guidance, is -50% / +300%. The range of uncertainty is beyond that for a typical Class 5 estimate due to the scope being proximally defined with today's relative solutions and technologies to resolving the identified needs; when the projects move forward into capital delivery over the longer term, it is anticipated that many differences and changes may arise as the known and defined engineering solutions are developed.

Douglas Leo of Value Management Strategies, Inc. (VMS) prepared this Basis of Estimate in coordination with King County WTD, the Brown and Caldwell Engineers team, and the VMS estimating team after receiving scope information from WTD in October 2019 through March 2020. This Basis of Estimate reflects VMS's best understanding of the estimating process for this project, as explained by King County WTD and Brown and Caldwell.

### 2.0 Project Scope Definition

---

This estimate includes all investigation, administration/owners' costs, engineering and design, purchases, fabrications, installations, process certifications, permitting, community impacts, and miscellaneous costs not specifically excluded elsewhere in this document.

Comprehensive Total Field Costs are generated from historical allowances, sources such as WTD estimating tools, historical costs, and RS Means/VMS estimating databases. All supporting indirect costs were generated from the WTD PRISM historical database. All costs included in the estimate reflect the best understanding of requirements as they existed at the time this estimate was prepared.

The scope of Alternative 4C is to provide year-round nitrogen removal (MLE and Sidestream Bioaugmentation) and an effluent TIN limit of 8mg/L with reduced secondary treatment capacity. The scope was developed to a Conceptual Design level adequate to assess operations and maintenance issues, energy impacts, permitting and code compliance issues, constructability, and estimated costs.

The Project Estimate was prepared utilizing the following Work Breakdown Structure (WBS) in order to provide clarity and transparency to the estimated costs. The scope as identified for the alternative is described below in accordance with the WBS. Details are based on the known and defined scope in the design documents provided. See section 3.0 for a detailed list of Design Documents.

- A. Primary Effluent (PE)
  - *Not included in the scope for this alternative.*
- B. Aeration Basins
  - General
    - Demolish Existing Aerators
    - Construct New Aeration Basin Trains – purchase and install
    - Aeration Basin Interior walls
    - Aeration Basin Retention Wall – purchase and install

## BASIS OF ESTIMATE

Project Name	<b>West Point Treatment Plant Nitrogen Removal - Alternative 4C</b>		
Project Number:		Date:	March 05, 2020

- Contractor Permit Fees at 1.0% Direct Costs
- C. Membrane Basins
  - *Not included in the scope for this alternative.*
- D. Internal Mixed Liquor Return (IMLR) Pumping
  - IMLR Pump
  - 48" CS Pipe in Aeration Basin
  - Contractor Permit Fees at 1.0% Direct Costs
- E. Return Activated Sludge (RAS) Pump
  - Extend Piping From Existing Pumps to New Aeration Basins – purchase and install
  - Contractor Permit Fees at 1.0% Direct Costs
- F. Sidestream Anammox
  - *Not included in the scope for this alternative.*
- G. Supplemental Methanol System
  - Supplemental Methanol 15,000-gallon System – purchase and install
  - Contractor Permit Fees at 1.0% Direct Costs
- H. Supplemental Alkalinity System
  - Supplemental Alkalinity 45,000-gallon System – purchase and install
  - Contractor Permit Fees at 1.0% Direct Costs
- I. Aeration Blowers
  - Aeration Blowers – purchase and install
  - Aeration Blower Diffusers – purchase and install
  - BAR Diffusers – purchase and install
  - Demolition Allowance
  - Contractor Permit Fees at 1.0% Direct Costs
- J. Aeration Basin Mixers
  - Aeration Basin Mixers – purchase and install
  - Contractor Permit Fees at 1.0% Direct Costs
- K. Sidestream Bioaugmentation
  - Bioaugmentation Pumps – purchase and install
  - Concrete Tank – purchase and install
  - Bubble Diffusers
  - Contractor Permit Fees at 1.0% Direct Costs
- L. Tertiary Pumps
  - *Not included in the scope for this alternative.*
- M. Tertiary Fixed Film System
  - *Not included in the scope for this alternative.*
- N. Aeration / MBR Odor Control
  - *Not included in the scope for this alternative.*
- O. Primary Clarifier / Aerated Grit Tank
  - *Not included in the scope for this alternative.*
- P. Miscellaneous Scope
  - Parking Garage to Accommodate 30 Spaces

## BASIS OF ESTIMATE

Project Name	<b>West Point Treatment Plant Nitrogen Removal - Alternative 4C</b>		
Project Number:		Date:	March 05, 2020

- Temporary Dock
- Large Crane at Loading Dock
- Barge Charges with Tug
- Methanol Piping
- Aeration Air to Aeration Basins
- 132-inch RCP Pipe Extension, Valves and Controls – purchase and install
- PE Pipe
- RAS Piping
- Centrate to Anammox
- Archeological Services
- Site Mitigation
- Tribal Agreements
- Contractor Permit Fees at 1.0% Direct Costs

### 3.0 Design Basis

---

This is an AACE International Class 5 estimate with all required documentation. The estimate is based on engineering deliverables, scoping documentation, discussions with the project team, and all supporting information and documentation provided in October 2019 through March 2020.

Engineering conceptual scope was provided in the following estimating deliverables. These are the most complete scoping documents that were available to the estimating provider.

Engineering and Estimating Deliverables provided include:

- West Point Treatment Process, King County WTD
- Scope Questions to Brown Caldwell – answered 10.17.19
- Brown & Caldwell Markup, Existing HPO Retrofit Assumptions for MLE (Alt 2A/2B/3A/4A/4C)
- Brown & Caldwell Markup, Existing HPO Retrofit Assumptions for 4SMB (Alt 2C/3D/4D/4E)
- Brown & Caldwell Markup, Existing HPO Aerator Demo
- Brown & Caldwell Markup, Existing Secondary Clarifier Demo (Alt3A/3D)
- Brown & Caldwell Markup, Existing Liquid Oxygen Tanks Demo (All Alt. except Alt 1)
- Brown & Caldwell Markup, Existing Oxygen Generation Facility Demo (All Alt except Alt 1)
- WPTP Nitrogen Removal Study, Layout Flow Paths, Brown and Caldwell, All Alternatives
- WPTP Nitrogen Removal Study, All Layouts, Brown and Caldwell, All Alternatives
- Anammox Equipment, Budgetary Price, Brown and Caldwell, All Alternatives
- BW Reference Drawings, Brown & Caldwell, dated: 10.20.2006
- WPTP, Cost Estimating Assumptions, Brown & Caldwell, version 0
- Aeration Basin Mechanical Drawings Package, King County WTD, dated: 1991
- Aeration Basin Structural Drawings, King County WTD, dated: 1991
- WPTP, Drawing Location Numbers, King County WTD, dated: 04.26.2018
- WPTP, Facility Plan, King County WTD, dated: 07.2017
- WPTP, Oxygen Generation Bldg. Drawings, King County WTD, dated: 1992
- WPTP, Perspective Overview, King County WTD, dated: 02.24.2017
- WPTP, Secondary Clarifiers Drawings, King County WTD, dated: 1991
- WPTP, Yard Piping Drawings (1,2,3), King County WTD, dated: 1996

Equipment Quotes:



## BASIS OF ESTIMATE

Project Name	<b>West Point Treatment Plant Nitrogen Removal - Alternative 4C</b>		
Project Number:		Date:	March 05, 2020

- Aeration Blowers, Equipment Quotation, Next Turbo, dated: 09.27.19
- MBR, Equipment Quotation, Suez, dated: 10.01.19
- PE Screens, Equipment Quotation, Huber Technology, dated: 10.02.19
- Sidestream Anammox, Equipment Quotation, Ovivo, dated: 09.06.19

### 4.0 Planning Basis

---

The following planning basis assumptions were made for the project estimate:

- No project construction plan is in place at this time.
- The assumed execution strategy is a standard workweek with limited overtime.
- No unusual site conditions have been considered as part of this estimate.
- Adequate available power exists at the site.

### 5.0 Cost Basis

---

- All allied and indirect project costs (allowances for indeterminates, change order allowance, engineering, permitting, WTD staffing, etc.) have been estimated using WTD's PRISM cost model which is baselined to historical project costs.
- The estimate was performed based on drawings, sketches, and project information provided by King County and Brown and Caldwell Engineers.
- WTD is using a PRISM cost model dated January 26, 2017. All Allied and indirect project costs have been estimated using the new WTD PRISM cost model baselined to historical project costs.
- Additional technical project complexity factors for WTD indirect project costs have been introduced and incorporated into project allied costs to allow for development of an additional WTD indirect cost allowance, based upon the unique characteristics of the project.
- Equipment factors were developed utilizing historical data which accounts for specific install of the identified equipment within a normal battery limit. Specific scope relative to this project was used in the equipment factor determination. Factors for each specific type of equipment reflect the different complexity of the installation. Engineering supplied equipment costs were multiplied by the factors in order to estimate direct construction cost for the purchase and install of the equipment.
- Estimated costs incorporate prevailing King County wage rates.
- All costs were estimated in 1<sup>st</sup> quarter 2020 dollars.

### 6.0 Allowances

---

The level and types of allowances used in the estimate is as follows (common percentages for each alternative are shown and any estimate-specific differences are indicated):

- Sales Tax was included as 10.1% applied to the base construction cost, including the design and change order contingencies.

## BASIS OF ESTIMATE

Project Name	<b>West Point Treatment Plant Nitrogen Removal - Alternative 4C</b>		
Project Number:		Date:	March 05, 2020

- A 25% Allowance for Indeterminates (AFI) is applied to the base construction cost. The AFI is an allowance that accounts for the cost of known but undefined requirements necessary for a complete and workable project. The AFI accounts for elements that are not explicitly shown in the project documents to be further defined as part of the design development and project delivery process. The AFI is carried at 25% at conceptual design, based on the WTD project delivery process.
- Allowance of 10% for potential construction change orders.
- Allowance of 0.2% of the primary construction amount for miscellaneous direct capital costs.
- Allowance of 1.5% of the primary construction amount for permitting and other agency support.
- Allowance of 1.8% of the primary construction amount for miscellaneous services and material.
- Allowance of 0.65% of the primary construction amount for Non-WTD Support.
- Allowance of 1.0% of the primary construction amount for art initiatives.
- Allowance of 0.5% of the total project cost for sustainability.
- Allowance of 16.09% of the primary construction amount for Engineering Design Services.
- Allowance of 8.36% of the primary construction amount for Construction Management Services.
- Allowance of 15.84% of the primary construction amount for WTD Staff.
- Allowance of 1% of Directs Costs was included for Contractor Permit Fees.
- Allowance for application of total project contingency (see *Contingency* section below).
- Allowance of 0% was included for Escalation as the estimate is produced in current year (2020) dollars.
- Additional estimating allowances for WTD indirect costs of approximately \$71.68 million have been included in the Total Project Cost estimate by using a moderate degree of complexity rating for Design Engineering, Community Relations, Environmental Planning and Management, Project Management, and Project Controls and a high degree of complexity rating for all other indirect costs. Complexity factors were calibrated based on comments received from King County on March 4, 2020.
  - An allowance of \$43.64 million for Design and Construction Consulting
  - An allowance of \$5.04 million for Permitting & Other Agency Support
  - An allowance of \$23.00 million for WTD Staff Labor

## 7.0 Assumptions

---

Any other assumptions made by the estimator but not documented elsewhere in the estimate basis are included in this section.

- All costs included in the estimate reflect the best understanding of requirements as they existed at the time the estimates were prepared. Any modifications to the present scope and/or location of the project site may have substantial cost and schedule impacts.
- The engineering design will be performed by an external consultant engineer.

## BASIS OF ESTIMATE

Project Name	<b>West Point Treatment Plant Nitrogen Removal - Alternative 4C</b>		
Project Number:		Date:	March 05, 2020

- Construction management will not be performed “in-house” by WTD. It will be performed by an external consultant construction manager.
- The project will generally align with the WTD PRISM cost model for Treatment projects.
- All work will always be performed utilizing safe work methods.
- Work will be sequenced to minimize standard process, service and community interruptions. However, no costs are included to address sequencing necessary keep the plant operational during construction.
- No costs are included for any new facilities that would be required, beyond the scope of this project to replace any lost capacity to the WPTP.
- It is assumed that the best improvement solution is included in the project scope(s).
- There will be some degree of productivity loss due to the site location. Some degree of productivity loss is included in the estimated costs. Any unusual site conditions are not accounted for in this estimate.
- Any additional work discovered during project implementation would need to be either a supplemental approval of added scope or be approved as an additional project.
- This project will be engineered to meet Washington State area seismic requirements.
- A degree of minimal cost rounding will occur during the normal estimating process.
- No allowance is included for Material Pricing Uncertainty.
- Power is readily available in the general area of this project. No new power sources are included in the scope of this project.
- It is assumed that some general material contamination is present. The estimate covers minimal cost of removal wherever the contamination is disturbed during construction. This cost is covered in productivity rates utilized in the estimate.
- It is assumed that the scope only requires 2” dia. methanol piping instead of any concrete channel structure.

### 8.0 Exclusions

---

All potential items of cost which might be associated with the project but for which no costs have been included are listed below:

- No asbestos removal costs are included.
- No estimated costs are included for any potential delays due to interferences.
- No costs are included for utility relocations.
- No costs are included for temporary construction easements.
- No costs are included for street use or street improvement permits.
- No costs are included for additional scope beyond that as detailed in the current scope of work.

## BASIS OF ESTIMATE

Project Name	<b>West Point Treatment Plant Nitrogen Removal - Alternative 4C</b>		
Project Number:		Date:	March 05, 2020

### 9.0 Exceptions

---

This estimate is classified as a King County Wastewater Treatment Division Class 5 estimate based on an AACE International Class 5 estimate, with no exceptions per the King County WTD project process, for the scope as known at the time of the estimate preparation.

### 10.0 Risks (Threats and Opportunities)

---

At the time of estimate preparation, a formal risk analysis session had not been conducted. General potential risks are listed below.

- There is a risk that additional scope, technology advances or major deviation from the suggested project scope will adversely impact cost and schedule.
- Future unknown or changing site conditions present a risk around productivities, schedule, and costs.
- More stringent or completely new regulations, usage fees, permitting, or environmental impacts may result in risks that could adversely impact cost and schedule.
- Potential complex construction and constructability issues could arise during construction, resulting in major design/construction changes.
- The space constraints could significantly impact assumed productivities and crew sizes identified for the estimated concept, resulting in increased costs due to loss of production.
- The scheduled timing of project execution will greatly impact the bottom-line costs. There is risk related to labor availability and fluctuating commodity and equipment pricing in the timeframe between this early conceptual estimate and the actual execution of the project. Rising costs due to inflation, escalation and competing major worldwide projects pose the possibility of noticeable project cost and schedule increases.
- Weather conditions and emergency service interruptions present the possibility of negative schedule and cost impacts.
- Any possible coordination with other agencies could result in potential impacts on costs, schedule and Project Definition process.
- There is a risk that stakeholders could oppose the proposed design or prefer a different approach or site to be selected, resulting in schedule delays and a higher cost alternative.

## **BASIS OF ESTIMATE**

Project Name	<b>West Point Treatment Plant Nitrogen Removal - Alternative 4C</b>		
Project Number:		Date:	March 05, 2020

### **11.0 Contingency**

---

Contingency is a cost element of the estimate used to cover uncertainties and unforeseeable elements of cost within the defined project scope. Contingency covers inadequacies in project scope definition, estimating methods, and estimating data. Contingency specifically excludes changes in project scope, and unforeseen major events such as earthquakes, prolonged labor strikes, etc.

A 30% Project Contingency was added to the base estimate of Total Project Costs (direct and indirect) as a result of the project estimating process and in accordance with the King County WTD project delivery process.

The estimating analysis resulted in a project contingency of approximately \$237.71 million (US\$).

The total project cost at a 50% confidence level (P50) is typically used for funding and baselining of a project at this stage and level of engineering and project development. The P50 confidence level suggests that there is a 50% cumulative probability of project cost under-run (or 50% probability of exceedance) at this dollar amount for the presently defined and known project scope.

### **12.0 Management Reserve**

---

No allocation of costs was included in this estimate for Management Reserves.

Contingency is not intended to cover the costs for changes in project scope. If the project needs to provide an allowance for anticipated changes in scope or to cover the costs for items that may be required but have not yet been specifically identified as being included in the current project scope, then that amount of cost should be identified here.

### **13.0 Reconciliation**

---

Reconciliation was not conducted at this time.

### **14.0 Benchmarking**

---

All included Allied Costs as supplied by the PRISM historical database have been benchmarked against a similar portfolio of recently completed projects.

### **15.0 Estimate Quality Assurance Plan**

---

No reviews of total project costs have been conducted outside the reviews conducted within Brown and Caldwell and VMS estimating team. It is anticipated that upon completion of this estimate, reviews will happen between the estimate provider and WTD.

### **16.0 Attachments**

---

#### **Attachment: Estimate Deliverables**

Engineering and Estimating Deliverables provided include:

- West Point Treatment Process, King County WTD
- Scope Questions to Brown Caldwell – answered 10.17.19

## BASIS OF ESTIMATE

Project Name	<b>West Point Treatment Plant Nitrogen Removal - Alternative 4C</b>		
Project Number:		Date:	March 05, 2020

- Brown & Caldwell Markup, Existing HPO Retrofit Assumptions for MLE (Alt 2A/2B/3A/4A/4C)
- Brown & Caldwell Markup, Existing HPO Retrofit Assumptions for 4SMB (Alt 2C/3D/4D/4E)
- Brown & Caldwell Markup, Existing HPO Aerator Demo
- Brown & Caldwell Markup, Existing Secondary Clarifier Demo (Alt3A/3D)
- Brown & Caldwell Markup, Existing Liquid Oxygen Tanks Demo (All Alt. except Alt 1)
- Brown & Caldwell Markup, Existing Oxygen Generation Facility Demo (All Alt except Alt 1)
- WPTP Nitrogen Removal Study, Layout Flow Paths, Brown and Caldwell, All Alternatives
- WPTP Nitrogen Removal Study, All Layouts, Brown and Caldwell, All Alternatives
- Anammox Equipment, Budgetary Price, Brown and Caldwell, All Alternatives
- BW Reference Drawings, Brown & Caldwell, dated: 10.20.2006
- WPTP, Cost Estimating Assumptions, Brown & Caldwell, version 0
- Aeration Basin Mechanical Drawings Package, King County WTD, dated: 1991
- Aeration Basin Structural Drawings, King County WTD, dated: 1991
- WPTP, Drawing Location Numbers, King County WTD, dated: 04.26.2018
- WPTP, Facility Plan, King County WTD, dated: 07.2017
- WPTP, Oxygen Generation Bldg. Drawings, King County WTD, dated: 1992
- WPTP, Perspective Overview, King County WTD, dated: 02.24.2017
- WPTP, Secondary Clarifiers Drawings, King County WTD, dated: 1991
- WPTP, Yard Piping Drawings (1,2,3), King County WTD, dated: 1996

### Equipment Quotes:

- Aeration Blowers, Equipment Quotation, Next Turbo, dated: 09.27.19
- MBR, Equipment Quotation, Suez, dated: 10.01.19
- PE Screens, Equipment Quotation, Huber Technology, dated: 10.02.19
- Sidestream Anammox, Equipment Quotation, Ovivo, dated: 09.06.19



# King County

Department of Natural Resources and Parks  
Wastewater Treatment Division

## Project Planning and Delivery Section

### BASIS OF ESTIMATE

---

Project Name	<b>West Point Treatment Plant Nitrogen Removal - Alternative 4D</b>
Project Number	
Date Prepared	March 05, 2020
Requested by	Tiffany Knapp, King County WTD
Prepared by	Douglas W. Leo, CCP, CEP, FRICS, FAACE Hon. Life, (VMS, Inc.)
Estimate Classification	WTD Class 5
Estimate Purpose	King County Class 5 Concept Screening
Estimate ID (Version)	7
Project Manager	Eron Jacobson, King County WTD
Project Control Engineer	
Cc or Distribution List	

*Note that the accuracy of the associated cost estimate is dependent upon the various underlying assumptions, inclusions, and exclusions described herein. Actual project costs may differ and can be significantly affected by factors such as changes in the external environment, the manner in which the project is executed and controlled, and other factors that may impact the estimate basis or otherwise affect the project. Estimate accuracy ranges are only assessments based upon the cost estimating methods and data employed in preparing the estimate and are not a guarantee of actual project costs.*



## BASIS OF ESTIMATE

Project Name	<b>West Point Treatment Plant Nitrogen Removal - Alternative 4D</b>		
Project Number:		Date:	March 05, 2020

### 1.0 Purpose

---

The purpose of this estimate is to provide cost information to support King County's West Point Treatment Plant (WPTP) Flows and Loading Alternative Evaluation for the Nitrogen Removal Project. A series of alternatives have been developed for project evaluation to determine the best engineering and project cost solution.

This estimate was prepared to establish a King County Wastewater Treatment Division (WTD) pre-Class 5 conceptual cost estimate to provide order of magnitude cost to support WTD's capital project identification and budgeting process for Total Project Costs. The WTD pre-Class 5 estimate provides similar documentation to that of an AACE International Class 5 estimate. The range of anticipated project costs, per WTD estimating guidance, is -50% / +300%. The range of uncertainty is beyond that for a typical Class 5 estimate due to the scope being proximally defined with today's relative solutions and technologies to resolving the identified needs; when the projects move forward into capital delivery over the longer term, it is anticipated that many differences and changes may arise as the known and defined engineering solutions are developed.

Douglas Leo of Value Management Strategies, Inc. (VMS) prepared this Basis of Estimate in coordination with King County WTD, the Brown and Caldwell Engineers team, and the VMS estimating team after receiving scope information from WTD in October 2019 thru March 2020. This Basis of Estimate reflects VMS's best understanding of the estimating process for this project, as explained by King County WTD and Brown and Caldwell.

### 2.0 Project Scope Definition

---

This estimate includes all investigation, administration/owners' costs, engineering and design, purchases, fabrications, installations, process certifications, permitting, community impacts, and miscellaneous costs not specifically excluded elsewhere in this document.

Comprehensive Total Field Costs are generated from historical allowances, sources such as WTD estimating tools, historical costs, and RS Means/VMS estimating databases. All supporting indirect costs were generated from the WTD PRISM historical database. All costs included in the estimate reflect the best understanding of requirements as they existed at the time this estimate was prepared.

The scope of Alternative 4D is to provide year-round nitrogen removal (4SMB and Sidestream Anammox) and an effluent TIN limit of 8mg/L with reduced secondary treatment capacity. The scope was developed to a Conceptual Design level adequate to assess operations and maintenance issues, energy impacts, permitting and code compliance issues, constructability, and estimated costs.

The Project Estimate was prepared utilizing the following Work Breakdown Structure (WBS) in order to provide clarity and transparency to the estimated costs. The scope as identified for the alternative is described below in accordance with the WBS. Details are based on the known and defined scope in the design documents provided. See section 3.0 for a detailed list of Design Documents.

- A. Primary Effluent (PE)
  - *Not included in the scope for this alternative.*
- B. Aeration Basins
  - General
    - Demolish Existing Aerators
    - New Aeration Basin Trains – purchase and install
    - Aeration Basin Interior Walls
    - Baffle Wall in Existing Aeration Basins – purchase and install

## BASIS OF ESTIMATE

Project Name	<b>West Point Treatment Plant Nitrogen Removal - Alternative 4D</b>		
Project Number:		Date:	March 05, 2020

- Aeration Basin Retention Wall – purchase and install
  - Contractor Permit Fees at 1.0% Direct Costs
- C. Membrane Basins
  - *Not included in the scope for this alternative.*
- D. Internal Mixed Liquor Return (IMLR) Pumping
  - IMLR Pump
  - 48" CS Pipe per Aeration Basin
  - Contractor Permit Fees at 1.0% Direct Costs
- E. Return Activated Sludge (RAS) Pump
  - Extend Piping from Existing Pumps to New Aeration Basins – purchase and install
  - Contractor Permit Fees at 1.0% Direct Costs
- F. Sidestream Anammox
  - Sidestream Anammox – purchase and install
  - Pumps / Skimmer / Chain / Flight for Sedimentation Tank / Mixers – purchase and install
  - Centrate EQ Tank (80,000-gal) – purchase and install
  - Centrate Sedimentation Tank (151,000-gal) – purchase and install
  - Anammox Reactor Tanks (375,000-gal) – purchase and install
  - Contractor Permit Fees at 1.0% Direct Costs
- G. Supplemental Methanol System
  - Supplemental Methanol 15,000-gallon System – purchase and install
  - Contractor Permit Fees at 1.0% Direct Costs
- H. Supplemental Alkalinity System
  - Supplemental Alkalinity 60,000-gallon System – purchase and install
  - Contractor Permit Fees at 1.0% Direct Costs
- I. Aeration Blowers
  - Aeration Blowers – purchase and install
  - Aeration Blower Diffusers – purchase and install
  - Demolition Allowance
  - Contractor Permit Fees at 1.0% Direct Costs
- J. Aeration Basin Mixers
  - Aeration Basin Mixers – purchase and install
  - Contractor Permit Fees at 1.0% Direct Costs
- K. Sidestream Bioaugmentation
  - *Not included in the scope for this alternative.*
- L. Tertiary Pumps
  - *Not included in the scope for this alternative.*
- M. Tertiary Fixed Film System
  - *Not included in the scope for this alternative.*
- N. Aeration / MBR Odor Control
  - *Not included in the scope for this alternative.*
- O. Primary Clarifier / Aerated Grit Tank
  - *Not included in the scope for this alternative.*

## BASIS OF ESTIMATE

Project Name	<b>West Point Treatment Plant Nitrogen Removal - Alternative 4D</b>		
Project Number:		Date:	March 05, 2020

### P. Miscellaneous Scope

- Parking Garage to Accommodate 30 Spaces
- Temporary Dock
- Large Crane at Loading Dock
- Barge Charges with Tug
- Methanol Piping
- Aeration Air to Aeration Basin
- 132-inch RCP Pipe Extension, Valves and Controls – purchase and install
- PE Pipe
- Centrate to Anammox
- Archeological Services
- Site mitigation
- Tribal Agreements
- Contractor Permit Fees at 1.0% Direct Costs

## 3.0 Design Basis

---

This is an AACE International Class 5 estimate with all required documentation. The estimate is based on engineering deliverables, scoping documentation, discussions with the project team, and all supporting information and documentation provided in October 2019 thru March 2020.

Engineering conceptual scope was provided in the following estimating deliverables. These are the most complete scoping documents that were available to the estimating provider.

Engineering and Estimating Deliverables provided include:

- West Point Treatment Process, King County WTD
- Scope Questions to Brown Caldwell – answered 10.17.19
- Brown & Caldwell Markup, Existing HPO Retrofit Assumptions for MLE (Alt 2A/2B/3A/4A/4C)
- Brown & Caldwell Markup, Existing HPO Retrofit Assumptions for 4SMB (Alt 2C/3D/4D/4E)
- Brown & Caldwell Markup, Existing HPO Aerator Demo
- Brown & Caldwell Markup, Existing Secondary Clarifier Demo (Alt3A/3D)
- Brown & Caldwell Markup, Existing Liquid Oxygen Tanks Demo (All Alt. except Alt 1)
- Brown & Caldwell Markup, Existing Oxygen Generation Facility Demo (All Alt except Alt 1)
- WPTP Nitrogen Removal Study, Layout Flow Paths, Brown and Caldwell, All Alternatives
- WPTP Nitrogen Removal Study, All Layouts, Brown and Caldwell, All Alternatives
- Anammox Equipment, Budgetary Price, Brown and Caldwell, All Alternatives
- BW Reference Drawings, Brown & Caldwell, dated: 10.20.2006
- WPTP, Cost Estimating Assumptions, Brown & Caldwell, version 0
- Aeration Basin Mechanical Drawings Package, King County WTD, dated: 1991
- Aeration Basin Structural Drawings, King County WTD, dated: 1991
- WPTP, Drawing Location Numbers, King County WTD, dated: 04.26.2018
- WPTP, Facility Plan, King County WTD, dated: 07.2017
- WPTP, Oxygen Generation Bldg. Drawings, King County WTD, dated: 1992
- WPTP, Perspective Overview, King County WTD, dated: 02.24.2017
- WPTP, Secondary Clarifiers Drawings, King County WTD, dated: 1991
- WPTP, Yard Piping Drawings (1,2,3), King County WTD, dated: 1996

## BASIS OF ESTIMATE

Project Name	<b>West Point Treatment Plant Nitrogen Removal - Alternative 4D</b>		
Project Number:		Date:	March 05, 2020

Equipment Quotes:

- Aeration Blowers, Equipment Quotation, Next Turbo, dated: 09.27.19
- MBR, Equipment Quotation, Suez, dated: 10.01.19
- PE Screens, Equipment Quotation, Huber Technology, dated: 10.02.19
- Sidestream Anammox, Equipment Quotation, Ovivo, dated: 09.06.19

### 4.0 Planning Basis

---

The following planning basis assumptions were made for the project estimate:

- No project construction plan is in place at this time.
- The assumed execution strategy is a standard workweek with limited overtime.
- No unusual site conditions have been considered as part of this estimate.
- Adequate available power exists at the site.

### 5.0 Cost Basis

---

- All allied and indirect project costs (allowances for indeterminates, change order allowance, engineering, permitting, WTD staffing, etc.) have been estimated using WTD's PRISM cost model which is baselined to historical project costs.
- The estimate was performed based on drawings, sketches, and project information provided by King County and Brown and Caldwell Engineers.
- WTD is using a PRISM cost model dated January 26, 2017. All Allied and indirect project costs have been estimated using the new WTD PRISM cost model baselined to historical project costs.
- Additional technical project complexity factors for WTD indirect project costs have been introduced and incorporated into project allied costs to allow for development of an additional WTD indirect cost allowance, based upon the unique characteristics of the project.
- Equipment factors were developed utilizing historical data which accounts for specific install of the identified equipment within a normal battery limit. Specific scope relative to this project was used in the equipment factor determination. Factors for each specific type of equipment reflect the different complexity of the installation. Engineering supplied equipment costs were multiplied by the factors in order to estimate direct construction cost for the purchase and install of the equipment.
- Estimated costs incorporate prevailing King County wage rates.
- All costs were estimated in 1<sup>st</sup> quarter 2020 dollars.

### 6.0 Allowances

---

The level and types of allowances used in the estimate is as follows (common percentages for each alternative are shown and any estimate-specific differences are indicated):

- Sales Tax was included as 10.1% applied to the base construction cost, including the design and change order contingencies.

## BASIS OF ESTIMATE

Project Name	<b>West Point Treatment Plant Nitrogen Removal - Alternative 4D</b>		
Project Number:		Date:	March 05, 2020

- A 25% Allowance for Indeterminates (AFI) is applied to the base construction cost. The AFI is an allowance that accounts for the cost of known but undefined requirements necessary for a complete and workable project. The AFI accounts for elements that are not explicitly shown in the project documents to be further defined as part of the design development and project delivery process. The AFI is carried at 25% at conceptual design, based on the WTD project delivery process.
- Allowance of 10% for potential construction change orders.
- Allowance of 0.2% of the primary construction amount for miscellaneous direct capital costs.
- Allowance of 1.5% of the primary construction amount for permitting and other agency support.
- Allowance of 1.8% of the primary construction amount for miscellaneous services and material.
- Allowance of 0.65% of the primary construction amount for Non-WTD Support.
- Allowance of 1.0% of the primary construction amount for art initiatives.
- Allowance of 0.5% of the total project cost for sustainability.
- Allowance of 16.02% of the primary construction amount for Engineering Design Services.
- Allowance of 8.30% of the primary construction amount for Construction Management Services.
- Allowance of 15.81% of the primary construction amount for WTD Staff.
- Allowance of 1% of Directs Costs was included for Contractor Permit Fees.
- Allowance for application of total project contingency (see *Contingency* section below).
- Allowance of 0% was included for Escalation as the estimate is produced in current year (2020) dollars.
- Additional estimating allowances for WTD indirect costs of approximately \$73.53 million have been included in the Total Project Cost estimate by using a moderate degree of complexity rating for Design Engineering, Community Relations, Environmental Planning and Management, Project Management, and Project Controls and a high degree of complexity rating for all other indirect costs. Complexity factors were calibrated based on comments received from King County on March 4, 2020.
  - An allowance of \$44.69 million for Design and Construction Consulting
  - An allowance of \$5.19 million for Permitting & Other Agency Support
  - An allowance of \$23.64 million for WTD Staff Labor

## 7.0 Assumptions

---

Any other assumptions made by the estimator but not documented elsewhere in the estimate basis are included in this section.

- All costs included in the estimate reflect the best understanding of requirements as they existed at the time the estimates were prepared. Any modifications to the present scope and/or location of the project site may have substantial cost and schedule impacts.
- The engineering design will be performed by an external consultant engineer.

## BASIS OF ESTIMATE

Project Name	<b>West Point Treatment Plant Nitrogen Removal - Alternative 4D</b>		
Project Number:		Date:	March 05, 2020

- Construction management will not be performed “in-house” by WTD. It will be performed by an external consultant construction manager.
- The project will generally align with the WTD PRISM cost model for Treatment projects.
- All work will always be performed utilizing safe work methods.
- Work will be sequenced to minimize standard process, service and community interruptions. However, no costs are included to address sequencing necessary keep the plant operational during construction.
- No costs are included for any new facilities that would be required, beyond the scope of this project to replace any lost capacity to the WPTP.
- It is assumed that the best improvement solution is included in the project scope(s).
- There will be some degree of productivity loss due to the site location. Some degree of productivity loss is included in the estimated costs. Any unusual site conditions are not accounted for in this estimate.
- Any additional work discovered during project implementation would need to be either a supplemental approval of added scope or be approved as an additional project.
- This project will be engineered to meet Washington State area seismic requirements.
- A degree of minimal cost rounding will occur during the normal estimating process.
- No allowance is included for Material Pricing Uncertainty.
- Power is readily available in the general area of this project. No new power sources are included in the scope of this project.
- It is assumed that some general material contamination is present. The estimate covers minimal cost of removal wherever the contamination is disturbed during construction. This cost is covered in productivity rates utilized in the estimate.
- It is assumed that the scope only requires 2” dia. methanol piping instead of any concrete channel structure.

### 8.0 Exclusions

---

All potential items of cost which might be associated with the project but for which no costs have been included are listed below:

- No asbestos removal costs are included.
- No estimated costs are included for any potential delays due to interferences.
- No costs are included for utility relocations.
- No costs are included for temporary construction easements.
- No costs are included for street use or street improvement permits.
- No costs are included for additional scope beyond that as detailed in the current scope of work.

## **BASIS OF ESTIMATE**

Project Name	<b>West Point Treatment Plant Nitrogen Removal - Alternative 4D</b>		
Project Number:		Date:	March 05, 2020

### **9.0 Exceptions**

---

This estimate is classified as a King County Wastewater Treatment Division Class 5 estimate based on an AACE International Class 5 estimate, with no exceptions per the King County WTD project process, for the scope as known at the time of the estimate preparation.

### **10.0 Risks (Threats and Opportunities)**

---

At the time of estimate preparation, a formal risk analysis session had not been conducted. General potential risks are listed below.

- There is a risk that additional scope, technology advances or major deviation from the suggested project scope will adversely impact cost and schedule.
- Future unknown or changing site conditions present a risk around productivities, schedule, and costs.
- More stringent or completely new regulations, usage fees, permitting, or environmental impacts may result in risks that could adversely impact cost and schedule.
- Potential complex construction and constructability issues could arise during construction, resulting in major design/construction changes.
- The space constraints could significantly impact assumed productivities and crew sizes identified for the estimated concept, resulting in increased costs due to loss of production.
- The scheduled timing of project execution will greatly impact the bottom-line costs. There is risk related to labor availability and fluctuating commodity and equipment pricing in the timeframe between this early conceptual estimate and the actual execution of the project. Rising costs due to inflation, escalation and competing major worldwide projects pose the possibility of noticeable project cost and schedule increases.
- Weather conditions and emergency service interruptions present the possibility of negative schedule and cost impacts.
- Any possible coordination with other agencies could result in potential impacts on costs, schedule and Project Definition process.
- There is a risk that stakeholders could oppose the proposed design or prefer a different approach or site to be selected, resulting in schedule delays and a higher cost alternative.



## **BASIS OF ESTIMATE**

Project Name	<b>West Point Treatment Plant Nitrogen Removal - Alternative 4D</b>		
Project Number:		Date:	March 05, 2020

### **11.0 Contingency**

---

Contingency is a cost element of the estimate used to cover uncertainties and unforeseeable elements of cost within the defined project scope. Contingency covers inadequacies in project scope definition, estimating methods, and estimating data. Contingency specifically excludes changes in project scope, and unforeseen major events such as earthquakes, prolonged labor strikes, etc.

A 30% Project Contingency was added to the base estimate of Total Project Costs (direct and indirect) as a result of the project estimating process and in accordance with the King County WTD project delivery process.

The estimating analysis resulted in a project contingency of approximately \$244.48 million (US\$).

The total project cost at a 50% confidence level (P50) is typically used for funding and baselining of a project at this stage and level of engineering and project development. The P50 confidence level suggests that there is a 50% cumulative probability of project cost under-run (or 50% probability of exceedance) at this dollar amount for the presently defined and known project scope.

### **12.0 Management Reserve**

---

No allocation of costs was included in this estimate for Management Reserves.

Contingency is not intended to cover the costs for changes in project scope. If the project needs to provide an allowance for anticipated changes in scope or to cover the costs for items that may be required but have not yet been specifically identified as being included in the current project scope, then that amount of cost should be identified here.

### **13.0 Reconciliation**

---

Reconciliation was not conducted at this time.

### **14.0 Benchmarking**

---

All included Allied Costs as supplied by the PRISM historical database have been benchmarked against a similar portfolio of recently completed projects.

### **15.0 Estimate Quality Assurance Plan**

---

No reviews of total project costs have been conducted outside the reviews conducted within Brown and Caldwell and VMS estimating team. It is anticipated that upon completion of this estimate, reviews will happen between the estimate provider and WTD.

### **16.0 Attachments**

---

#### **Attachment: Estimate Deliverables**

Engineering and Estimating Deliverables provided include:

- West Point Treatment Process, King County WTD
- Scope Questions to Brown Caldwell – answered 10.17.19

## BASIS OF ESTIMATE

Project Name	<b>West Point Treatment Plant Nitrogen Removal - Alternative 4D</b>		
Project Number:		Date:	March 05, 2020

- Brown & Caldwell Markup, Existing HPO Retrofit Assumptions for MLE (Alt 2A/2B/3A/4A/4C)
- Brown & Caldwell Markup, Existing HPO Retrofit Assumptions for 4SMB (Alt 2C/3D/4D/4E)
- Brown & Caldwell Markup, Existing HPO Aerator Demo
- Brown & Caldwell Markup, Existing Secondary Clarifier Demo (Alt3A/3D)
- Brown & Caldwell Markup, Existing Liquid Oxygen Tanks Demo (All Alt. except Alt 1)
- Brown & Caldwell Markup, Existing Oxygen Generation Facility Demo (All Alt except Alt 1)
- WPTP Nitrogen Removal Study, Layout Flow Paths, Brown and Caldwell, All Alternatives
- WPTP Nitrogen Removal Study, All Layouts, Brown and Caldwell, All Alternatives
- Anammox Equipment, Budgetary Price, Brown and Caldwell, All Alternatives
- BW Reference Drawings, Brown & Caldwell, dated: 10.20.2006
- WPTP, Cost Estimating Assumptions, Brown & Caldwell, version 0
- Aeration Basin Mechanical Drawings Package, King County WTD, dated: 1991
- Aeration Basin Structural Drawings, King County WTD, dated: 1991
- WPTP, Drawing Location Numbers, King County WTD, dated: 04.26.2018
- WPTP, Facility Plan, King County WTD, dated: 07.2017
- WPTP, Oxygen Generation Bldg. Drawings, King County WTD, dated: 1992
- WPTP, Perspective Overview, King County WTD, dated: 02.24.2017
- WPTP, Secondary Clarifiers Drawings, King County WTD, dated: 1991
- WPTP, Yard Piping Drawings (1,2,3), King County WTD, dated: 1996

### Equipment Quotes:

- Aeration Blowers, Equipment Quotation, Next Turbo, dated: 09.27.19
- MBR, Equipment Quotation, Suez, dated: 10.01.19
- PE Screens, Equipment Quotation, Huber Technology, dated: 10.02.19
- Sidestream Anammox, Equipment Quotation, Ovivo, dated: 09.06.19



# King County

Department of Natural Resources and Parks  
Wastewater Treatment Division

## Project Planning and Delivery Section

### BASIS OF ESTIMATE

---

Project Name	<b>West Point Treatment Plant Nitrogen Removal - Alternative 4E</b>
Project Number	
Date Prepared	March 05, 2020
Requested by	Tiffany Knapp, King County WTD
Prepared by	Douglas W. Leo, CCP, CEP, FRICS, FAACE Hon. Life, (VMS, Inc.)
Estimate Classification	WTD Class 5
Estimate Purpose	King County Class 5 Concept Screening
Estimate ID (Version)	7
Project Manager	Eron Jacobson, King County WTD
Project Control Engineer	
Cc or Distribution List	

*Note that the accuracy of the associated cost estimate is dependent upon the various underlying assumptions, inclusions, and exclusions described herein. Actual project costs may differ and can be significantly affected by factors such as changes in the external environment, the manner in which the project is executed and controlled, and other factors that may impact the estimate basis or otherwise affect the project. Estimate accuracy ranges are only assessments based upon the cost estimating methods and data employed in preparing the estimate and are not a guarantee of actual project costs.*

## BASIS OF ESTIMATE

Project Name	<b>West Point Treatment Plant Nitrogen Removal - Alternative 4E</b>		
Project Number:		Date:	March 05, 2020

### 1.0 Purpose

---

The purpose of this estimate is to provide cost information to support King County's West Point Treatment Plant (WPTP) Flows and Loading Alternative Evaluation for the Nitrogen Removal Project. A series of alternatives have been developed for project evaluation to determine the best engineering and project cost solution.

This estimate was prepared to establish a King County Wastewater Treatment Division (WTD) pre-Class 5 conceptual cost estimate to provide order of magnitude cost to support WTD's capital project identification and budgeting process for Total Project Costs. The WTD pre-Class 5 estimate provides similar documentation to that of an AACE International Class 5 estimate. The range of anticipated project costs, per WTD estimating guidance, is -50% / +300%. The range of uncertainty is beyond that for a typical Class 5 estimate due to the scope being proximally defined with today's relative solutions and technologies to resolving the identified needs; when the projects move forward into capital delivery over the longer term, it is anticipated that many differences and changes may arise as the known and defined engineering solutions are developed.

Douglas Leo of Value Management Strategies, Inc. (VMS) prepared this Basis of Estimate in coordination with King County WTD, the Brown and Caldwell Engineers team, and the VMS estimating team after receiving scope information from WTD in October 2019 through March 2020. This Basis of Estimate reflects VMS's best understanding of the estimating process for this project, as explained by King County WTD and Brown and Caldwell.

### 2.0 Project Scope Definition

---

This estimate includes all investigation, administration/owners' costs, engineering and design, purchases, fabrications, installations, process certifications, permitting, community impacts, and miscellaneous costs not specifically excluded elsewhere in this document.

Comprehensive Total Field Costs are generated from historical allowances, sources such as WTD estimating tools, historical costs, and RS Means/VMS estimating databases. All supporting indirect costs were generated from the WTD PRISM historical database. All costs included in the estimate reflect the best understanding of requirements as they existed at the time this estimate was prepared.

The scope of Alternative 4E is to provide year-round nitrogen removal (4SMB and Sidestream Bioaugmentation) and an effluent TIN limit of 8mg/L with reduced secondary treatment capacity. The scope was developed to a Conceptual Design level adequate to assess operations and maintenance issues, energy impacts, permitting and code compliance issues, constructability, and estimated costs.

The Project Estimate was prepared utilizing the following Work Breakdown Structure (WBS) in order to provide clarity and transparency to the estimated costs. The scope as identified for the alternative is described below in accordance with the WBS. Details are based on the known and defined scope in the design documents provided. See section 3.0 for a detailed list of Design Documents.

- A. Primary Effluent (PE)
  - *Not included in the scope for this alternative.*
- B. Aeration Basins
  - General
    - Demolish Existing Aerators – purchase and install
    - New Aeration Basin Trains – purchase and install
    - Aeration Basin Interior Walls
    - Baffle Walls in Existing Aeration Basins – purchase and install

## BASIS OF ESTIMATE

Project Name	<b>West Point Treatment Plant Nitrogen Removal - Alternative 4E</b>		
Project Number:		Date:	March 05, 2020

- Aeration Basin Retention Wall – purchase and install
- Contractor Permit Fees at 1.0% Direct Costs
- C. Membrane Basins
  - *Not included in the scope for this alternative.*
- D. Internal Mixed Liquor Return (IMLR) Pumping
  - IMLR Pump
  - 48" CS Pipe per Aeration Basin
  - Contractor Permit Fees at 1.0% Direct Costs
- E. Return Activated Sludge (RAS) Pump
  - Extend Piping From Existing Pumps to New Aeration Basins – purchase and install
  - Contractor Permit Fees at 1.0% Direct Costs
- F. Sidestream Anammox
  - *Not included in the scope for this alternative.*
- G. Supplemental Methanol System
  - Supplemental Methanol 15,000-gallon System – purchase and install
  - Contractor Permit Fees at 1.0% Direct Costs
- H. Supplemental Alkalinity System
  - Supplemental Alkalinity 60,000-gallon System – purchase and install
  - Contractor Permit Fees at 1.0% Direct Costs
- I. Aeration Blowers
  - Aeration Blowers – purchase and install
  - Aeration Blower Diffusers – purchase and install
  - BAR diffusers – purchase and install
  - Demolition Allowance
  - Contractor Permit Fees at 1.0% Direct Costs
- J. Aeration Basin Mixers for Anoxic Zones
  - Aeration Basin Mixers – purchase and install
  - Contractor Permit Fees at 1.0% Direct Costs
- K. Sidestream Bioaugmentation
  - Bioaugmentation Pumps – purchase and install
  - Concrete Tank – purchase and install
  - Fine Bubble Diffuser
  - Contractor Permit Fees at 1.0% Direct Costs
- L. Add fine bubble diffuser Tertiary Pumps
  - *Not included in the scope for this alternative.*
- M. Tertiary Fixed Film System
  - *Not included in the scope for this alternative.*
- N. Aeration / MBR Odor Control
  - *Not included in the scope for this alternative.*
- O. Primary Clarifier / Aerated Grit Tank
  - *Not included in the scope for this alternative.*
- P. Miscellaneous Scope

## BASIS OF ESTIMATE

Project Name	<b>West Point Treatment Plant Nitrogen Removal - Alternative 4E</b>		
Project Number:		Date:	March 05, 2020

- Parking Garage to Accommodate 30 Spaces
- Temporary Dock
- Large Crane at Loading Dock
- Barge Charges with Tug
- Methanol Piping
- Aeration Air to Aeration Basin
- 132-inch RCP Pipe Extension, Valves and Controls – purchase and install
- PE Pipe
- RAS Piping
- Centrate to Anammox
- Archeological Services
- Site Mitigation
- Tribal Agreements
- Contractor Permit Fees at 1.0% Direct Costs

### 3.0 Design Basis

---

This is an AACE International Class 5 estimate with all required documentation. The estimate is based on engineering deliverables, scoping documentation, discussions with the project team, and all supporting information and documentation provided in October 2019 through March 2020.

Engineering conceptual scope was provided in the following estimating deliverables. These are the most complete scoping documents that were available to the estimating provider.

Engineering and Estimating Deliverables provided include:

- West Point Treatment Process, King County WTD
- Scope Questions to Brown Caldwell – answered 10.17.19
- Brown & Caldwell Markup, Existing HPO Retrofit Assumptions for MLE (Alt 2A/2B/3A/4A/4C)
- Brown & Caldwell Markup, Existing HPO Retrofit Assumptions for 4SMB (Alt 2C/3D/4D/4E)
- Brown & Caldwell Markup, Existing HPO Aerator Demo
- Brown & Caldwell Markup, Existing Secondary Clarifier Demo (Alt3A/3D)
- Brown & Caldwell Markup, Existing Liquid Oxygen Tanks Demo (All Alt. except Alt 1)
- Brown & Caldwell Markup, Existing Oxygen Generation Facility Demo (All Alt except Alt 1)
- WPTP Nitrogen Removal Study, Layout Flow Paths, Brown and Caldwell, All Alternatives
- WPTP Nitrogen Removal Study, All Layouts, Brown and Caldwell, All Alternatives
- Anammox Equipment, Budgetary Price, Brown and Caldwell, All Alternatives
- BW Reference Drawings, Brown & Caldwell, dated: 10.20.2006
- WPTP, Cost Estimating Assumptions, Brown & Caldwell, version 0
- Aeration Basin Mechanical Drawings Package, King County WTD, dated: 1991
- Aeration Basin Structural Drawings, King County WTD, dated: 1991
- WPTP, Drawing Location Numbers, King County WTD, dated: 04.26.2018
- WPTP, Facility Plan, King County WTD, dated: 07.2017
- WPTP, Oxygen Generation Bldg. Drawings, King County WTD, dated: 1992
- WPTP, Perspective Overview, King County WTD, dated: 02.24.2017
- WPTP, Secondary Clarifiers Drawings, King County WTD, dated: 1991
- WPTP, Yard Piping Drawings (1,2,3), King County WTD, dated: 1996

## **BASIS OF ESTIMATE**

Project Name	<b>West Point Treatment Plant Nitrogen Removal - Alternative 4E</b>		
Project Number:		Date:	March 05, 2020

Equipment Quotes:

- Aeration Blowers, Equipment Quotation, Next Turbo, dated: 09.27.19
- MBR, Equipment Quotation, Suez, dated: 10.01.19
- PE Screens, Equipment Quotation, Huber Technology, dated: 10.02.19
- Sidestream Anammox, Equipment Quotation, Ovivo, dated: 09.06.19

### **4.0 Planning Basis**

---

The following planning basis assumptions were made for the project estimate:

- No project construction plan is in place at this time.
- The assumed execution strategy is a standard workweek with limited overtime.
- No unusual site conditions have been considered as part of this estimate.
- Adequate available power exists at the site.

### **5.0 Cost Basis**

---

- All allied and indirect project costs (allowances for indeterminates, change order allowance, engineering, permitting, WTD staffing, etc.) have been estimated using WTD's PRISM cost model which is baselined to historical project costs.
- The estimate was performed based on drawings, sketches, and project information provided by King County and Brown and Caldwell Engineers.
- WTD is using a PRISM cost model dated January 26, 2017. All Allied and indirect project costs have been estimated using the new WTD PRISM cost model baselined to historical project costs.
- Additional technical project complexity factors for WTD indirect project costs have been introduced and incorporated into project allied costs to allow for development of an additional WTD indirect cost allowance, based upon the unique characteristics of the project.
- Equipment factors were developed utilizing historical data which accounts for specific install of the identified equipment within a normal battery limit. Specific scope relative to this project was used in the equipment factor determination. Factors for each specific type of equipment reflect the different complexity of the installation. Engineering supplied equipment costs were multiplied by the factors in order to estimate direct construction cost for the purchase and install of the equipment.
- Estimated costs incorporate prevailing King County wage rates.
- All costs were estimated in 1<sup>st</sup> quarter 2020 dollars.

### **6.0 Allowances**

---

The level and types of allowances used in the estimate is as follows (common percentages for each alternative are shown and any estimate-specific differences are indicated):

- Sales Tax was included as 10.1% applied to the base construction cost, including the design and change order contingencies.



## BASIS OF ESTIMATE

Project Name	<b>West Point Treatment Plant Nitrogen Removal - Alternative 4E</b>		
Project Number:		Date:	March 05, 2020

- A 25% Allowance for Indeterminates (AFI) is applied to the base construction cost. The AFI is an allowance that accounts for the cost of known but undefined requirements necessary for a complete and workable project. The AFI accounts for elements that are not explicitly shown in the project documents to be further defined as part of the design development and project delivery process. The AFI is carried at 25% at conceptual design, based on the WTD project delivery process.
- Allowance of 10% for potential construction change orders.
- Allowance of 0.2% of the primary construction amount for miscellaneous direct capital costs.
- Allowance of 0.88% of the primary construction amount for permitting and other agency support.
- Allowance of 1.8% of the primary construction amount for miscellaneous services and material.
- Allowance of 0.65% of the primary construction amount for Non-WTD Support.
- Allowance of 1.0% of the primary construction amount for art initiatives.
- Allowance of 0.5% of the total project cost for sustainability.
- Allowance of 16.05% of the primary construction amount for Engineering Design Services.
- Allowance of 8.32% of the primary construction amount for Construction Management Services.
- Allowance of 15.82% of the primary construction amount for WTD Staff.
- Allowance of 1% of Directs Costs was included for Contractor Permit Fees.
- Allowance for application of total project contingency (see *Contingency* section below).
- Allowance of 0% was included for Escalation as the estimate is produced in current year (2020) dollars.
- Additional estimating allowances for WTD indirect costs of approximately \$72.9 million have been included in the Total Project Cost estimate by using a moderate degree of complexity rating for Design Engineering, Community Relations, Environmental Planning and Management, Project Management, and Project Controls and a high degree of complexity rating for all other indirect costs. Complexity factors were calibrated based on comments received from King County on March 4, 2020.
  - An allowance of \$44.33 million for Design and Construction Consulting
  - An allowance of \$5.13 million for Permitting & Other Agency Support
  - An allowance of \$23.43 million for WTD Staff Labor

## 7.0 Assumptions

---

Any other assumptions made by the estimator but not documented elsewhere in the estimate basis are included in this section.

- All costs included in the estimate reflect the best understanding of requirements as they existed at the time the estimates were prepared. Any modifications to the present scope and/or location of the project site may have substantial cost and schedule impacts.
- The engineering design will be performed by an external consultant engineer.

## BASIS OF ESTIMATE

Project Name	<b>West Point Treatment Plant Nitrogen Removal - Alternative 4E</b>		
Project Number:		Date:	March 05, 2020

- Construction management will not be performed “in-house” by WTD. It will be performed by an external consultant construction manager.
- The project will generally align with the WTD PRISM cost model for Treatment projects.
- All work will always be performed utilizing safe work methods.
- Work will be sequenced to minimize standard process, service and community interruptions. However, no costs are included to address sequencing necessary keep the plant operational during construction.
- No costs are included for any new facilities that would be required, beyond the scope of this project to replace any lost capacity to the WPTP.
- It is assumed that the best improvement solution is included in the project scope(s).
- There will be some degree of productivity loss due to the site location. Some degree of productivity loss is included in the estimated costs. Any unusual site conditions are not accounted for in this estimate.
- Any additional work discovered during project implementation would need to be either a supplemental approval of added scope or be approved as an additional project.
- This project will be engineered to meet Washington State area seismic requirements.
- A degree of minimal cost rounding will occur during the normal estimating process.
- No allowance is included for Material Pricing Uncertainty.
- Power is readily available in the general area of this project. No new power sources are included in the scope of this project.
- It is assumed that some general material contamination is present. The estimate covers minimal cost of removal wherever the contamination is disturbed during construction. This cost is covered in productivity rates utilized in the estimate.
- It is assumed that the scope only requires 2” dia. methanol piping instead of any concrete channel structure.

### 8.0 Exclusions

---

All potential items of cost which might be associated with the project but for which no costs have been included are listed below:

- No asbestos removal costs are included.
- No estimated costs are included for any potential delays due to interferences.
- No costs are included for utility relocations.
- No costs are included for temporary construction easements.
- No costs are included for street use or street improvement permits.
- No costs are included for additional scope beyond that as detailed in the current scope of work.

## BASIS OF ESTIMATE

Project Name	<b>West Point Treatment Plant Nitrogen Removal - Alternative 4E</b>		
Project Number:		Date:	March 05, 2020

### 9.0 Exceptions

---

This estimate is classified as a King County Wastewater Treatment Division Class 5 estimate based on an AACE International Class 5 estimate, with no exceptions per the King County WTD project process, for the scope as known at the time of the estimate preparation.

### 10.0 Risks (Threats and Opportunities)

---

At the time of estimate preparation, a formal risk analysis session had not been conducted. General potential risks are listed below.

- There is a risk that additional scope, technology advances or major deviation from the suggested project scope will adversely impact cost and schedule.
- Future unknown or changing site conditions present a risk around productivities, schedule, and costs.
- More stringent or completely new regulations, usage fees, permitting, or environmental impacts may result in risks that could adversely impact cost and schedule.
- Potential complex construction and constructability issues could arise during construction, resulting in major design/construction changes.
- The space constraints could significantly impact assumed productivities and crew sizes identified for the estimated concept, resulting in increased costs due to loss of production.
- The scheduled timing of project execution will greatly impact the bottom-line costs. There is risk related to labor availability and fluctuating commodity and equipment pricing in the timeframe between this early conceptual estimate and the actual execution of the project. Rising costs due to inflation, escalation and competing major worldwide projects pose the possibility of noticeable project cost and schedule increases.
- Weather conditions and emergency service interruptions present the possibility of negative schedule and cost impacts.
- Any possible coordination with other agencies could result in potential impacts on costs, schedule and Project Definition process.
- There is a risk that stakeholders could oppose the proposed design or prefer a different approach or site to be selected, resulting in schedule delays and a higher cost alternative.

## **BASIS OF ESTIMATE**

Project Name	<b>West Point Treatment Plant Nitrogen Removal - Alternative 4E</b>		
Project Number:		Date:	March 05, 2020

### **11.0 Contingency**

---

Contingency is a cost element of the estimate used to cover uncertainties and unforeseeable elements of cost within the defined project scope. Contingency covers inadequacies in project scope definition, estimating methods, and estimating data. Contingency specifically excludes changes in project scope, and unforeseen major events such as earthquakes, prolonged labor strikes, etc.

A 30% Project Contingency was added to the base estimate of Total Project Costs (direct and indirect) as a result of the project estimating process and in accordance with the King County WTD project delivery process.

The estimating analysis resulted in a project contingency of approximately \$242.15 million (US\$).

The total project cost at a 50% confidence level (P50) is typically used for funding and baselining of a project at this stage and level of engineering and project development. The P50 confidence level suggests that there is a 50% cumulative probability of project cost under-run (or 50% probability of exceedance) at this dollar amount for the presently defined and known project scope.

### **12.0 Management Reserve**

---

No allocation of costs was included in this estimate for Management Reserves.

Contingency is not intended to cover the costs for changes in project scope. If the project needs to provide an allowance for anticipated changes in scope or to cover the costs for items that may be required but have not yet been specifically identified as being included in the current project scope, then that amount of cost should be identified here.

### **13.0 Reconciliation**

---

Reconciliation was not conducted at this time.

### **14.0 Benchmarking**

---

All included Allied Costs as supplied by the PRISM historical database have been benchmarked against a similar portfolio of recently completed projects.

### **15.0 Estimate Quality Assurance Plan**

---

No reviews of total project costs have been conducted outside the reviews conducted within Brown and Caldwell and VMS estimating team. It is anticipated that upon completion of this estimate, reviews will happen between the estimate provider and WTD.

### **16.0 Attachments**

---

#### **Attachment: Estimate Deliverables**

Engineering and Estimating Deliverables provided include:

- West Point Treatment Process, King County WTD
- Scope Questions to Brown Caldwell – answered 10.17.19

## BASIS OF ESTIMATE

Project Name	<b>West Point Treatment Plant Nitrogen Removal - Alternative 4E</b>		
Project Number:		Date:	March 05, 2020

- Brown & Caldwell Markup, Existing HPO Retrofit Assumptions for MLE (Alt 2A/2B/3A/4A/4C)
- Brown & Caldwell Markup, Existing HPO Retrofit Assumptions for 4SMB (Alt 2C/3D/4D/4E)
- Brown & Caldwell Markup, Existing HPO Aerator Demo
- Brown & Caldwell Markup, Existing Secondary Clarifier Demo (Alt3A/3D)
- Brown & Caldwell Markup, Existing Liquid Oxygen Tanks Demo (All Alt. except Alt 1)
- Brown & Caldwell Markup, Existing Oxygen Generation Facility Demo (All Alt except Alt 1)
- WPTP Nitrogen Removal Study, Layout Flow Paths, Brown and Caldwell, All Alternatives
- WPTP Nitrogen Removal Study, All Layouts, Brown and Caldwell, All Alternatives
- Anammox Equipment, Budgetary Price, Brown and Caldwell, All Alternatives
- BW Reference Drawings, Brown & Caldwell, dated: 10.20.2006
- WPTP, Cost Estimating Assumptions, Brown & Caldwell, version 0
- Aeration Basin Mechanical Drawings Package, King County WTD, dated: 1991
- Aeration Basin Structural Drawings, King County WTD, dated: 1991
- WPTP, Drawing Location Numbers, King County WTD, dated: 04.26.2018
- WPTP, Facility Plan, King County WTD, dated: 07.2017
- WPTP, Oxygen Generation Bldg. Drawings, King County WTD, dated: 1992
- WPTP, Perspective Overview, King County WTD, dated: 02.24.2017
- WPTP, Secondary Clarifiers Drawings, King County WTD, dated: 1991
- WPTP, Yard Piping Drawings (1,2,3), King County WTD, dated: 1996

### Equipment Quotes:

- Aeration Blowers, Equipment Quotation, Next Turbo, dated: 09.27.19
- MBR, Equipment Quotation, Suez, dated: 10.01.19
- PE Screens, Equipment Quotation, Huber Technology, dated: 10.02.19
- Sidestream Anammox, Equipment Quotation, Ovivo, dated: 09.06.19

## **Attachment D: Budgetary Proposals for Equipment**

---



# BUDGET PROPOSAL

**Project Name: King County, WA**

**Huber Proposal Number: Budgetary**

**Equipment: Seven (7) x DSL-STAR 2200/2/4000**

**Bid Date: October 2, 2019**

**Huber Contact: John Lewis, Regional Sales Director-West**

**(704) 995-5451**

**Represented By: Doug Allie, Goble Sampson**

**(425) 392-0491**



**Huber Technology, Inc.**

**9735 NorthCross Center Court  
Suite A  
Huntersville, NC 28078**

**Phone: (704) 949-1010**

**Fax: (704) 949-1020**



## DESCRIPTION

### Drum Screen LIQUID In Channel Perforated Plate Screen

**Maximum Design Flow: 300 MGD @150 mg/l TSS**

**50 MGD per screen**

Including:

- Seven (7) x DSL-STAR/4000/2 6 Duty, 1 Standby
- Channel Mounted
- 304 L Stainless Steel Construction; pickled and passivated in acid bath
- Shafted screw with integrated maintenance free bearing
- Folded Star Shaped Screen basket; width: 7.2 ft (2200 mm).
- Screen basket; length 13 ft (4000 mm)
- Perforated plate spacing: 0.08" (2 mm)
- Polyurethane seal to prevent screenings bypass
- Class 1 Division 1 motor, 3-HP, 460 VAC, 3 phase, 60 Hz, Inverter Duty motor, to be used with VFD control, SF 1.0
- Wall mounted or stand-alone NEMA 4X stainless steel control panel suitable for Class 1 Division 1 environment
- Dual spray Bars operating intermittently
- Two (2) solenoid valve for spraybar, 2-inch, 120VAC, 2-way brass body, Class 1 Division 1
- One (1) solenoid valve for screening trough flush 2-inch, 120VAC, 2-way brass body, Class 1 Division 1
- Manufacturer's Services: Five (5) trip, Sixteen (16) service days for inspection, startup, testing, and training. Additional manufacturer's services are available on a per diem rate upon request.
- Automatic lubrication grease pump

**Price: \$3,000,000**

Notes

1. Detailed Equipment Specification, Drawing, and Formalized Proposal are available upon request.
2. If there are site-specific hydraulic constraints that must be applied, please consult Huber Technology's representative to ensure compatibility with the proposed system.
3. Budget estimate is based upon Huber Technology's Standard Design, Terms, & Conditions. Any deviation from these standards may result in a price adder.
4. This budget is based on Huber's standard control solutions. If Specific Controls requirement are needed Huber will change this budget.

# BUDGET PROPOSAL

**Project Name: King County, WA**

**Huber Proposal Number: Budgetary**

**Equipment: Three (3) x DSL-STAR 2200/2/3300**

**Bid Date: October 8, 2019**

**Huber Contact: John Lewis, Regional Sales Director-West**

**(704) 995-5451**

**Represented By: Doug Allie, Goble Sampson**

**(425) 392-0491**



**Huber Technology, Inc.**

**9735 NorthCross Center Court  
Suite A  
Huntersville, NC 28078**

**Phone: (704) 949-1010**

**Fax: (704) 949-1020**

## DESCRIPTION

### Drum Screen LIQUID In Channel Perforated Plate Screen

**Maximum Design Flow: 70 MGD @150 mg/l TSS**

**35 MGD per screen**

Including:

- Three (3) x DSL-STAR/3300/2 6 Duty, 1 Standby
- Channel Mounted
- 304 L Stainless Steel Construction; pickled and passivated in acid bath
- Shafted screw with integrated maintenance free bearing
- Folded Star Shaped Screen basket; width: 7.2 ft (2200 mm).
- Screen basket; length 11 ft (3300 mm)
- Perforated plate spacing: 0.08" (2 mm)
- Polyurethane seal to prevent screenings bypass
- Class 1 Division 1 motor, 3-HP, 460 VAC, 3 phase, 60 Hz, Inverter Duty motor, to be used with VFD control, SF 1.0
- Wall mounted or stand-alone NEMA 4X stainless steel control panel suitable for Class 1 Division 1 environment
- Dual spray Bars operating intermittently
- Two (2) solenoid valve for spraybar, 2-inch, 120VAC, 2-way brass body, Class 1 Division 1
- One (1) solenoid valve for screening trough flush 2-inch, 120VAC, 2-way brass body, Class 1 Division 1
- Manufacturer's Services: Three (3) trip, Nine (9) service days for inspection, startup, testing, and training. Additional manufacturer's services are available on a per diem rate upon request.
- Automatic lubrication grease pump

**Price: \$1,050,000**

Notes

1. Detailed Equipment Specification, Drawing, and Formalized Proposal are available upon request.
2. If there are site-specific hydraulic constraints that must be applied, please consult Huber Technology's representative to ensure compatibility with the proposed system.
3. Budget estimate is based upon Huber Technology's Standard Design, Terms, & Conditions. Any deviation from these standards may result in a price adder.
4. This budget is based on Huber's standard control solutions. If Specific Controls requirement are needed Huber will change this budget.

# Project Quotation



Projectname:	King County
Projectnumber:	193609
Date:	09/27/2019

More info on <http://www.next-turbo.com>



## 1. Scope of Delivery

### Summary

#### Project Details

Project:	King County <span style="color: green;">23</span>
Compressor type:	GTH-T50-XY
Compressor Control :	Discharge Diffuser & Inlet Guide vane control
Motor Size:	1750 HP, rated at 60 Hz, 4160 V
Number of Units:	4
Max. Power at design conditions:	1511.3 HP
Air volume turndown:	40-100%
Discharge temperature (a):	216 °F (worst case scenario)
Max Air speed discharge	3428 ft/min with NPS32
Design inlet air temperature:	90°F at 50%rH
Design airflow:	26525 SCFM at 14.7 PSIA, 68°F, 36% rH 28045 ACFM at 14.7 PSIA, 90°F, 50% rH
Design differential pressure:	12.7 PSIG
<b>BUDGET PRICE (4 UNITS)</b>	<b>\$2,300,000</b>

#### Project Details

Project:	King County <span style="color: green;">23</span>
Compressor type:	GTH-T50-XY
Compressor Control :	Discharge Diffuser & Inlet Guide vane control
Motor Size:	1500 HP, rated at 60 Hz, 4160 V
Number of Units:	4
Max. Power at design conditions:	1287.2 HP
Air volume turndown:	40-100%
Discharge temperature (a):	216 °F (worst case scenario)
Max Air speed discharge	3798 ft/min with NPS28
Design inlet air temperature:	90°F at 50%rH
Design airflow:	22500 SCFM at 14.7 PSIA, 68°F, 36% rH 23790 ACFM at 14.7 PSIA, 90°F, 50% rH
Design differential pressure:	12.7 PSIG
<b>BUDGET PRICE (4 UNITS)</b>	<b>\$2,260,000</b>

## Project Details

Project:	King County 
Compressor type:	GTH-T50-XY
Compressor Control :	Discharge Diffuser & Inlet Guide vane control
Motor Size:	1500 HP, rated at 60 Hz, 4160 V
Number of Units:	3
Max. Power at design conditions:	1230 HP
Air volume turndown:	40-100%
Discharge temperature (a):	216 °F (worst case scenario)
Max Air speed discharge	3629 ft/min with NPS28
Design inlet air temperature:	90°F at 50%rH
Design airflow:	21500 SCFM at 14.7 PSIA, 68°F, 36% rH 22732 ACFM at 14.7 PSIA, 90°F, 50% rH
Design differential pressure:	12.7 PSIG
<b>BUDGET PRICE (3 UNITS)</b>	<b>\$1,515,000</b>

## Project Details

Project:	King County 
Compressor type:	GTH-T50-XY
Compressor Control :	Discharge Diffuser & Inlet Guide vane control
Motor Size:	1500 HP, rated at 60 Hz, 4160 V
Number of Units:	3
Max. Power at design conditions:	1320.3 HP
Air volume turndown:	40-100%
Discharge temperature (a):	216 °F (worst case scenario)
Max Air speed discharge	3899 ft/min with NPS28
Design inlet air temperature:	90°F at 50%rH
Design airflow:	23100 SCFM at 14.7 PSIA, 68°F, 36% rH 24424 ACFM at 14.7 PSIA, 90°F, 50% rH
Design differential pressure:	12.7 PSIG
<b>BUDGET PRICE (3 UNITS)</b>	<b>\$1,515,000</b>

## Project Details

Project:	King County <span style="background-color: #00FF00;">3D</span>
Compressor type:	GTH-T50-XY
Compressor Control :	Discharge Diffuser & Inlet Guide vane control
Motor Size:	1250 HP, rated at 60 Hz, 4160 V
Number of Units:	3
Max. Power at design conditions:	1165.6 HP
Air volume turndown:	40-100%
Discharge temperature (a):	216 °F (worst case scenario)
Max Air speed discharge	3432 ft/min with NPS28
Design inlet air temperature:	90°F at 50%rH
Design airflow:	20333 SCFM at 14.7 PSIA, 68°F, 36% rH 21499 ACFM at 14.7 PSIA, 90°F, 50% rH
Design differential pressure:	12.7 PSIG
<b>BUDGET PRICE (3 UNITS)</b>	<b>\$1,460,000</b>

## Project Details

Project:	King County <span style="background-color: #00FF00;">3D</span>
Compressor type:	GTH-T50-XY
Compressor Control :	Discharge Diffuser & Inlet Guide vane control
Motor Size:	1250 HP, rated at 60 Hz, 4160 V
Number of Units:	3
Max. Power at design conditions:	1036.7 HP
Air volume turndown:	40-100%
Discharge temperature (a):	216 °F (worst case scenario)
Max Air speed discharge	3044 ft/min with NPS28
Design inlet air temperature:	90°F at 50%rH
Design airflow:	18033 SCFM at 14.7 PSIA, 68°F, 36% rH 19067 ACFM at 14.7 PSIA, 90°F, 50% rH
Design differential pressure:	12.7 PSIG
<b>BUDGET PRICE (3 UNITS)</b>	<b>\$1,460,000</b>



## Project Details

Project:	King County <b>40</b>
Compressor type:	GTH-T50-XY
Compressor Control :	Discharge Diffuser & Inlet Guide vane control
Motor Size:	1250 HP, rated at 60 Hz, 4160 V
Number of Units:	3
Max. Power at design conditions:	1128.9 HP
Air volume turndown:	40-100%
Discharge temperature (a):	216 °F (worst case scenario)
Max Air speed discharge	3319 ft/min with NPS28
Design inlet air temperature:	90°F at 50%rH
Design airflow:	19666 SCFM at 14.7 PSIA, 68°F, 36% rH 20793 ACFM at 14.7 PSIA, 90°F, 50% rH
Design differential pressure:	12.7 PSIG
<b>BUDGET PRICE (3 UNITS)</b>	<b>\$1,460,000</b>

## Project Details

Project:	King County <b>40</b>
Compressor type:	GTH-T50-XY
Compressor Control :	Discharge Diffuser & Inlet Guide vane control
Motor Size:	1250 HP, rated at 60 Hz, 4160 V
Number of Units:	3
Max. Power at design conditions:	1066.1 HP
Air volume turndown:	40-100%
Discharge temperature (a):	216 °F (worst case scenario)
Max Air speed discharge	3134 ft/min with NPS28
Design inlet air temperature:	90°F at 50%rH
Design airflow:	18566 SCFM at 14.7 PSIA, 68°F, 36% rH 19630 ACFM at 14.7 PSIA, 90°F, 50% rH
Design differential pressure:	12.7 PSIG
<b>BUDGET PRICE (3 UNITS)</b>	<b>\$1,460,000</b>

## Project Details

Project:	King County <span style="background-color: green; color: white;">11</span>
Compressor type:	GTH-T50-XY
Compressor Control :	Discharge Diffuser & Inlet Guide vane control
Motor Size:	1500 HP, rated at 60 Hz, 4160 V
Number of Units:	3
Max. Power at design conditions:	1246.5 HP
Air volume turndown:	40-100%
Discharge temperature (a):	216 °F (worst case scenario)
Max Air speed discharge	3680 ft/min with NPS28
Design inlet air temperature:	90°F at 50%rH
Design airflow:	21800 SCFM at 14.7 PSIA, 68°F, 36% rH 23050 ACFM at 14.7 PSIA, 90°F, 50% rH
Design differential pressure:	12.7 PSIG
<b>BUDGET PRICE (3 UNITS)</b>	<b>\$1,515,000</b>

# Blowers needed for Peak hour airflow	Alternative	Max month airflow (scfm)	Peak hour airflow (scfm)
4	2A	66,300	106,100
4	2B	56,200	90,000
3	2C	40,300	64,500
3	3A	43,300	69,300
3	3D	38,100	61,000
3	4A	33,800	54,100
3	4C	37,400	59,000
3	4D	34,800	55,700
3	4E	41,400	65,400

## Scope Selection base offer

ID	Item	Type/size	Included
1.	Geared Turbocompressor	GTH-T50-XY	✓
2.	Electrical drive motor - B5		✓
5.	Softstarter (MCC)		
6.	Inlet silencer/filter		✓
7.	Flexible Compensator		✓
8.	Discharge diffuser		✓
9.	Blow-off valve/ silencer		✓
10.	Checkvalve		✓
12.	Isolation valve (electrical)		✓
13.	Silencer blocks/ mounts		✓
14.	Local Control panel		✓

## Terms and Conditions

---

<b>Delivery time</b>	7/8 months – from factory order acceptance, Kansas City (MO) USA
<b>Delivery</b>	FCA Factory – Incoterms 2010
<b>Conditions</b>	See attached Terms & Conditions
<b>Payment plan</b>	<ul style="list-style-type: none"> <li>▪ 25% down payment with contract signature, net 30 days from invoice</li> <li>▪ 45% with purchasing of major parts such as motor/ gearbox; net 30 days from invoice</li> <li>▪ 20% at successful mechanical test; net 30 days from invoice</li> <li>▪ 10% at successful onsite commissioning, however not longer than 3 month after delivery, net 30 days from invoice</li> </ul>
<b>Offer Validity</b>	6 months from offer date – non binding for supplier
<b>Warranty</b>	24 months from start up, however not longer than 30 from delivery or supplier readiness notification
<b>Conservation</b>	Before shipping, compressors will be preserved for storage up to 6 months
<b>Packing</b>	
<b>Lubricants</b>	First lube oil filling is included
<b>Manuals</b>	All electronic files in English language are included in 1 CD/DVD.
<b>Documentation</b>	See attached list
<b>Mechanical test</b>	All compressors are mechanically tested before delivery, with issue of a test certificate.
<b>Quality &amp; tests</b>	See attached Inspection & Testing Plan (ITP)



## 4. General arrangement drawing (G&A) - preliminary

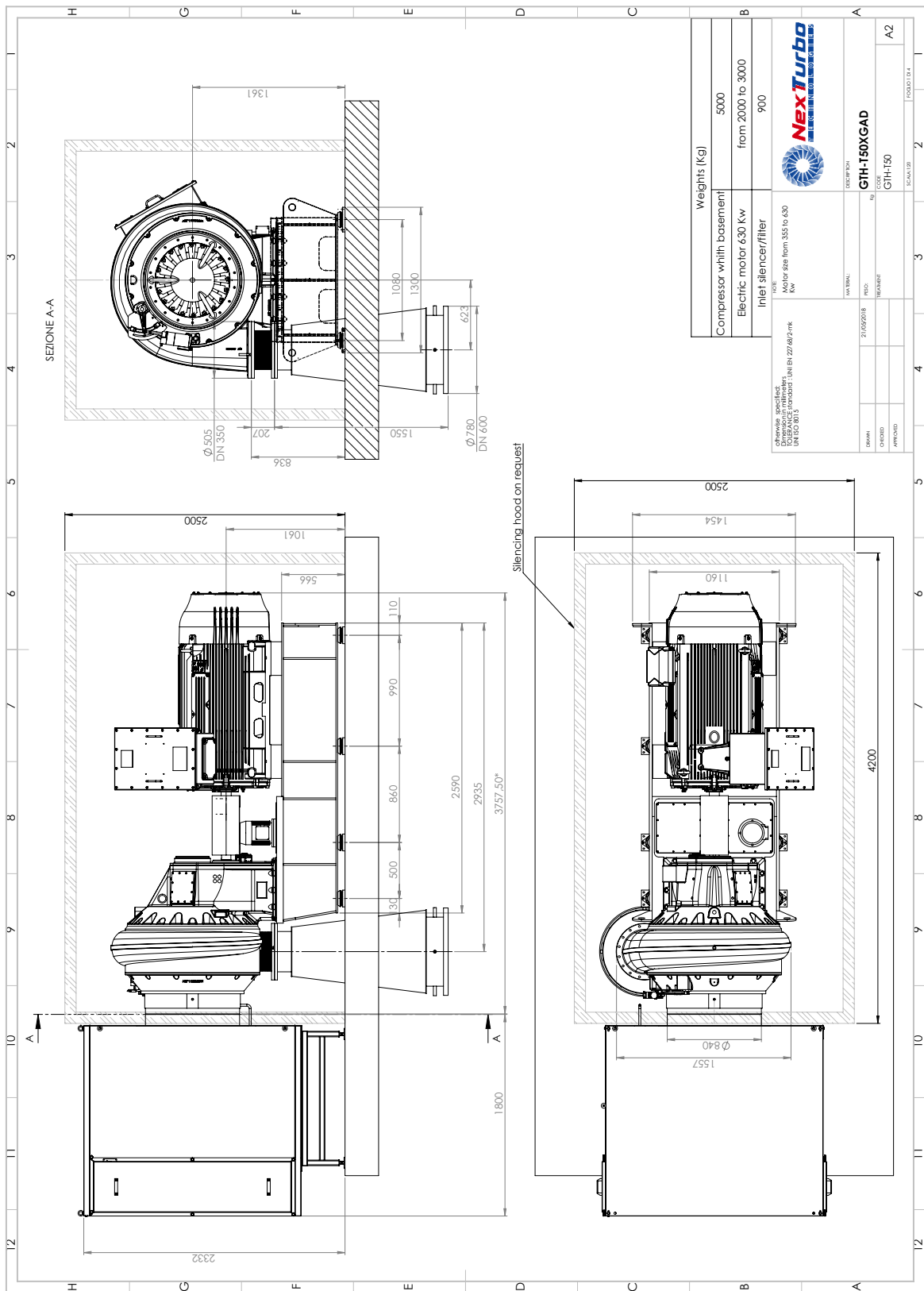

A meno di legge ci riserviamo la proprietà di questo documento con diritto di riproduzione o di rendere comunque noto a terzi senza nostra autorizzazione scritta.

## 5. Technical documents

### Oil Specification

Specification of lubricating oil applicable for compressors with anti-friction bearings (ball/roller bearings).

Compressor	Oil Type acc. DIN51502	Viscosity Index (min) acc. ISO2909	Viscosity min at 120 C	FZG STAGE min. DIN51354
GTH-T50	PAO	137	4.20	10

PAO = Synthetic oil, polyalfaolifine

### Suppliers

---

The following suppliers and oil types are recommended.

Company	Oil type
TOTAL	DACNIS SH 46
SHELL	MADRELA AS 46
<b>MOBIL</b>	<b>MOBIL SHC 624</b>
Q8	Q8 SCHUMANN 32
STATOIL	COMPWAY SX 32
ESSO	ESSO COMPRESSOR OIL RS32
TRIBOL	TRIBOL 1550/32
KLEBER	KLEBER SYNTH GEM 4-32
FUCHS	FUCHS COFRABAR P32



# Standard Surface Treatment

## Compressor Unit

---

Surfaces of compressor and equipment excl. armatures, all galvanized parts and stainless Supplier parts.  
Corrosion class of paint supplier: C3 according to ISO 12944. Suitable for temperatures up to 120°C.

### 1.1 Pre-Treatment

Cleaning by sand-blasting to obtain metallic radiance of surface according to ISO 8501-1, quality: SA 2 ½. If sand-blasting is not possible: Mechanical cleaning according to ISO 8501-01, quality ST3

### 1.2 Primer

2 x Corrosion protective primer, two component epoxy basis, wet-in-wet application. Product manufacturer: PPG Univer S.p.A, type: Epoxy primer H<sub>2</sub>O

Type of bond: Epoxy

Pigmentation: organic and inorganic pigments and anticorrosive pigments

Film thickness: min. 40 - 50 micro meter Dry film thickness (DFT)

Color: grey / RAL 7035

If the primer film is thinner than 40 micrometer, or if spots of corrosion are visible, or the adhesion is insufficient, the area must be cleansed again to ST3, and a new coating of primer must be applied.

### 1.3 Finishing Coat

2 x Top coat, two component epoxy. Product manufacturer: TECNA PPG Univer S.p.A, type: Tecnodur H<sub>2</sub>O

Type of bond: epoxy resins

Film thickness: min. 60 - 70 micro meter Dry film thickness (DFT)

Color: RAL 5015 (sky blue)

Total film thickness (primer + finishing coat): min. 100, max 130 micrometer Dry film thickness (DFT)

## Electric Motors

---

Motors are coated as per manufacturer standards.

Primer: 20 microns (DFT)

Finish: 50 microns (DFT)

Total film thickness: min. 70 micrometer Dry film thickness (DFT)

Color: RAL 5015 (sky blue)

<b>36" 8411 Quotation Curve</b>						<b>FAIRBANKS NIJHUIS™</b>			
<b>CURVE NUMBER:</b>	W-190258 A	<b>SPEED</b>	<b>DRIVER</b>	<b>DIAMETER</b>	<b>SPHERE</b>	<b>GUARANTEED VALUES</b>			
<b>REV.</b>	0	510 RPM	250 HP	AS REQ'D	2.90"	<b>FLOW</b>	<b>HEAD</b>	<b>BOWL EFF</b>	<b>HP</b>
THIS CURVE IS BASED ON THE ACTUAL TEST PERFORMANCE OF A SIMILAR PUMP. ONLY THE INDICATED POINT(S) IS GUARANTEED.		<b>STAGES</b>	<b>IMPELLER</b>	<b>DATE</b>	<b>BY</b>	41667	10.0	83.0	-----
		1	AS REQ'D	10/4/2019	JCM	-----	-----	-----	-----
		<b>I M L R</b>				-----	-----	-----	-----

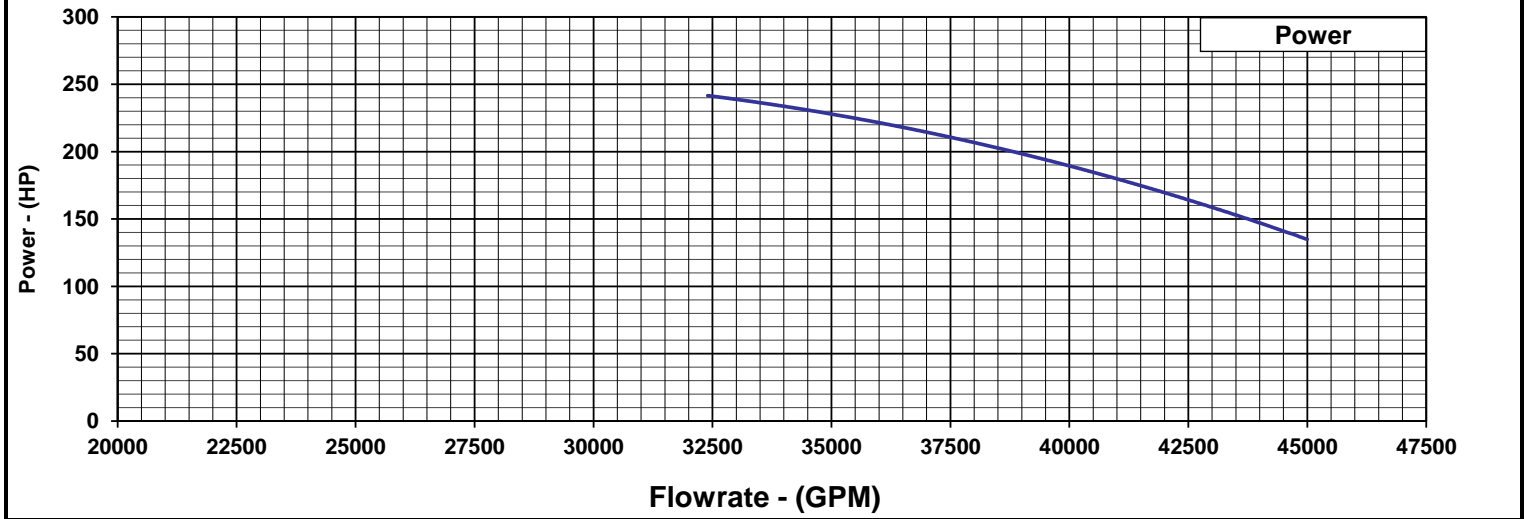
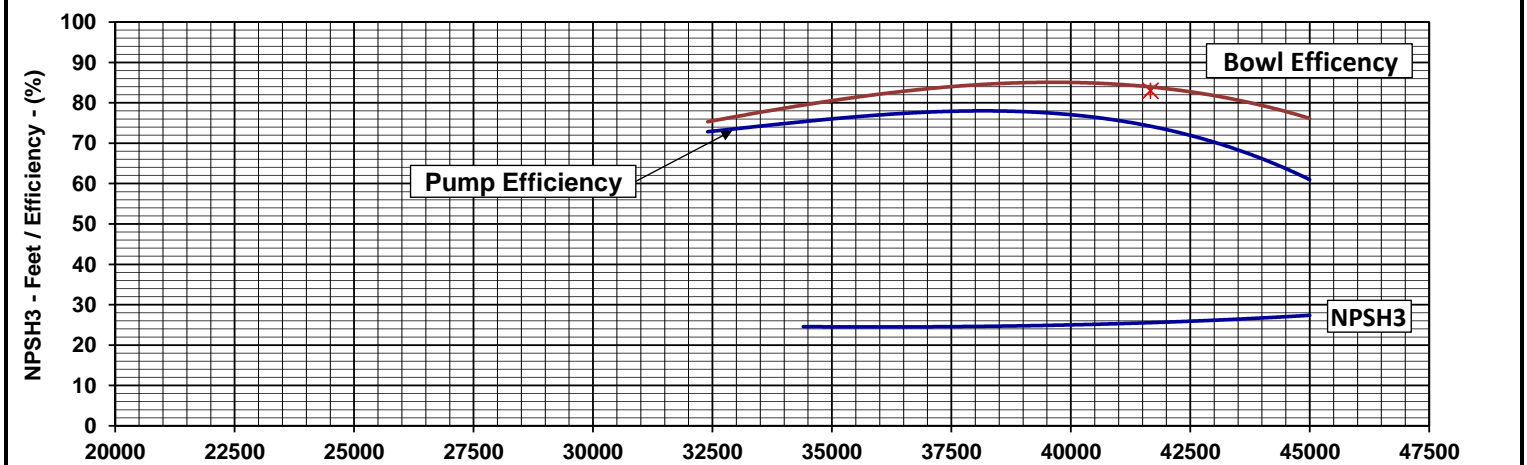
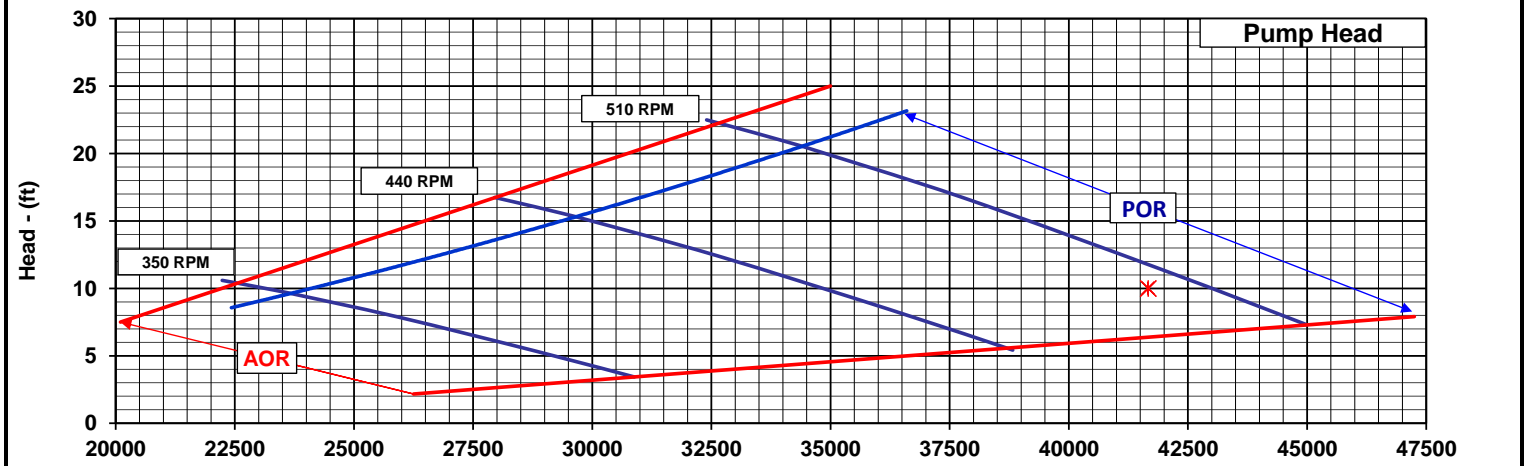

Price: \$240,000.00 Net Each

<b>30" 8411 Quotation Curve</b>		 <b>PENTAIR</b>				<b>FAIRBANKS NIJHUIS™</b>			
<b>CURVE NUMBER:</b>	W-190258 B	<b>SPEED</b>	<b>DRIVER</b>	<b>DIAMETER</b>	<b>SPHERE</b>	<b>GUARANTEED VALUES</b>			
<b>REV.</b>	0	590 RPM	200 HP	AS REQ'D	2.40"	<b>FLOW</b>	<b>HEAD</b>	<b>BOWL EFF</b>	<b>HP</b>
THIS CURVE IS BASED ON THE ACTUAL TEST PERFORMANCE OF A SIMILAR PUMP. ONLY THE INDICATED POINT(S) IS GUARANTEED.		<b>STAGES</b>	<b>IMPELLER</b>	<b>DATE</b>	<b>BY</b>	27778	10.0	83.0	----
		1	AS REQ'D	10/4/2019	JCM	----	----	----	----
		<b>I M L R</b>				----	----	----	----

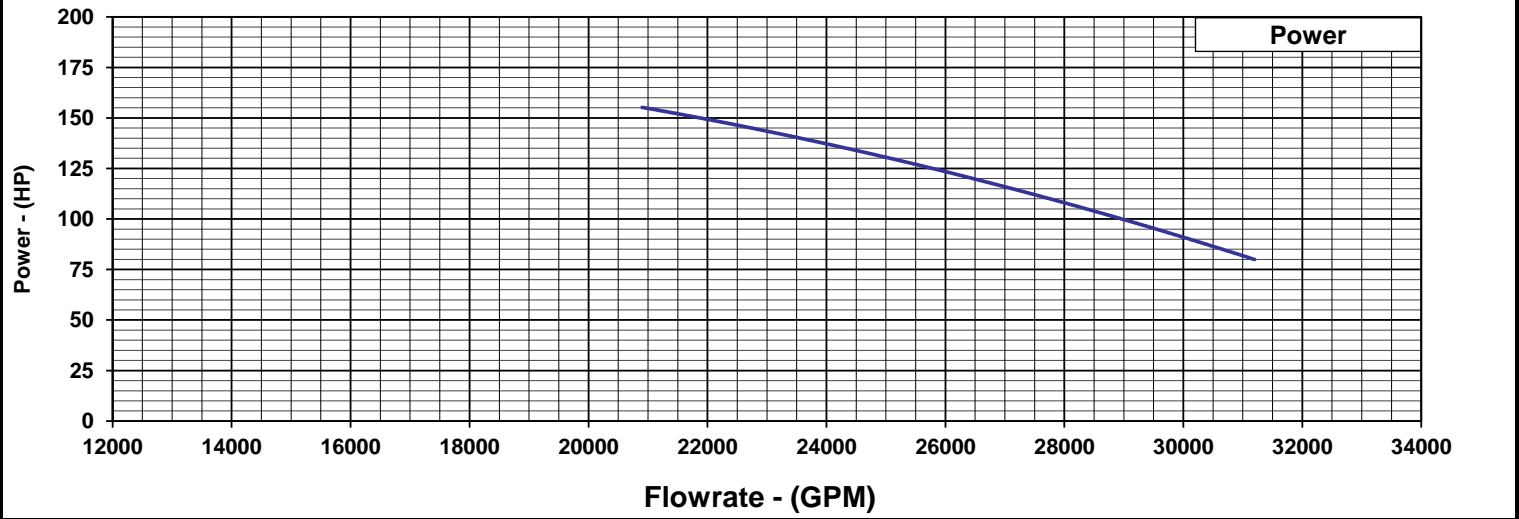
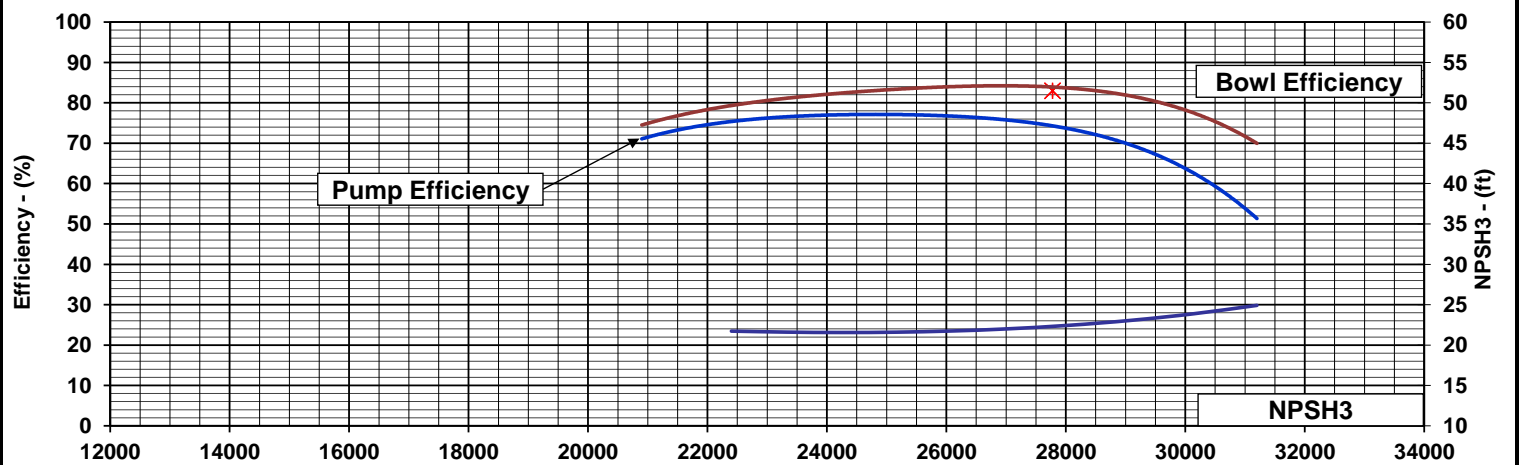
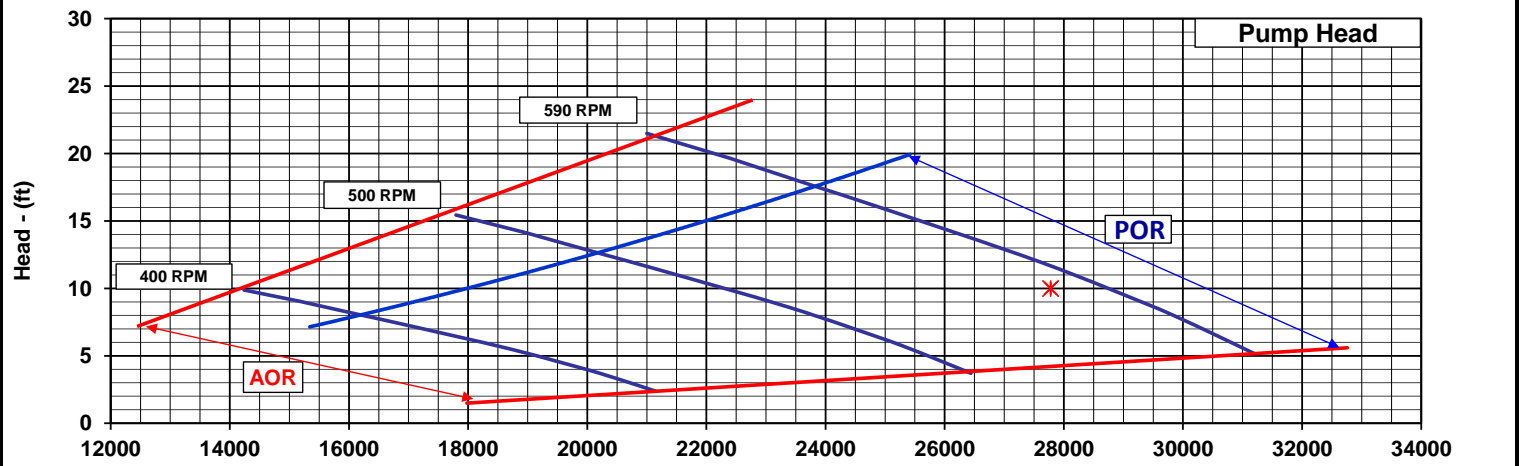

budget proposal for the  
**West Point WWTP**  
ZeeWeed\* membrane system

**submitted to:**  
**Brown & Caldwell**  
Seattle, WA

attention: Matt Winkler, P.E.

**October 1, 2019**

**proposal number: 380466 – revision 1**

**submitted by:**  
Chris Allen, P.E. - Regional Manager  
(503) 307-2238  
chris.allen@suez.com

**local representation by:**  
**APSCO**  
Joe Kernkamp  
(206) 890-4039  
jkernkamp@apsco-llc.com

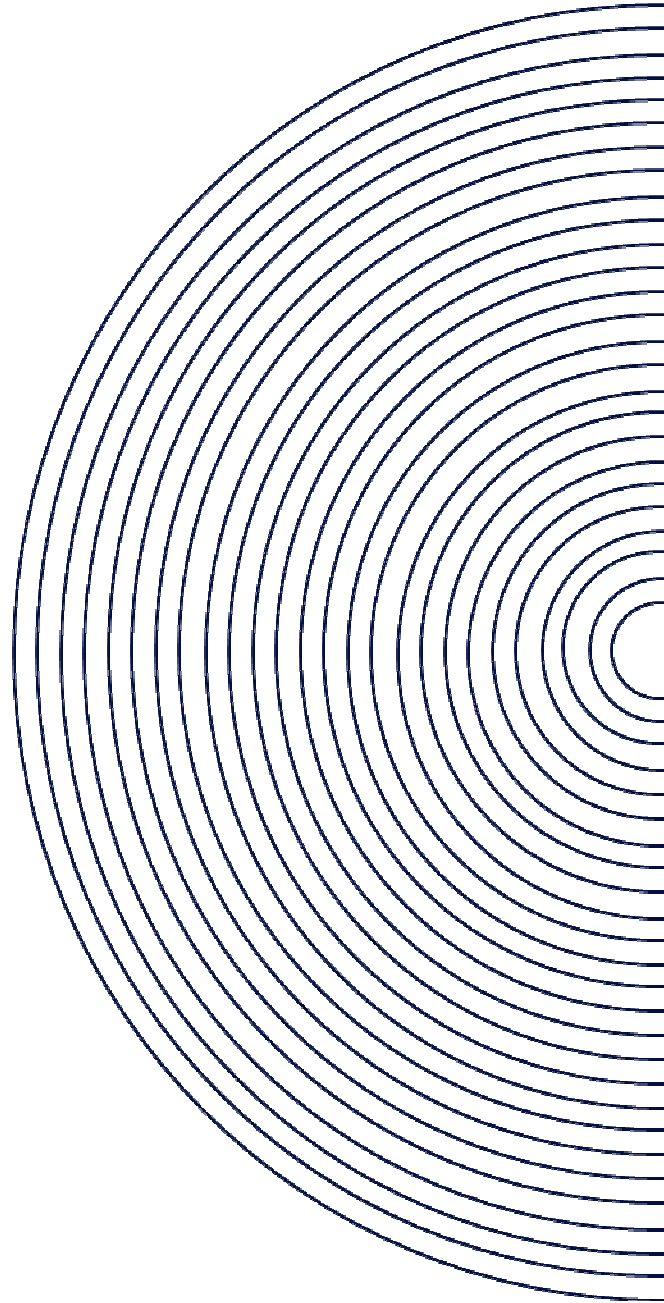

## table of contents

<b>1</b>	<b>basis of design .....</b>	<b>3</b>
1.1	influent flow data .....	3
1.2	influent quality .....	3
1.3	influent variability.....	4
1.4	effluent quality.....	4
<b>2</b>	<b>system design and scope.....</b>	<b>5</b>
2.1	ultrafiltration system design.....	6
2.1.1	alternative 2 .....	6
2.1.2	alternative 3 .....	7
2.3	scope of supply by SUEZ.....	8
<b>3</b>	<b>buyer scope of supply .....</b>	<b>11</b>
<b>4</b>	<b>commercial.....</b>	<b>13</b>
4.1	pricing .....	13
4.2	equipment shipment and delivery.....	13
4.3	freight terms .....	14
4.4	terms and conditions of sale.....	14

### **SUEZ Water Technologies & Solutions confidential and proprietary information**

The enclosed materials are considered proprietary property of SUEZ Water Technologies & Solutions (SUEZ). No assignments either implied or expressed, of intellectual property rights, data, know-how, trade secrets or licenses of use thereof are given. All information is provided exclusively to the addressee and agents of the addressee for the purposes of evaluation and is not to be reproduced or divulged to other parties, nor used for manufacture or other means, without the express written consent of SUEZ. The acceptance of this document will be construed as an acceptance of the foregoing.

\*The following are trademarks of SUEZ Water Technologies & Solutions and may be registered in one or more countries: InSight, LEAPmbr, LEAPprimary, Z-MOD, ZeeWeed, and ZENON

# 1 basis of design

The following membrane system designs are for the MBR retrofit at West Point WWTP located in Seattle, Washington and are offered based on the design parameters provided by Brown and Caldwell. The designs are based on flows of 300 mgd and 70 mgd, with and without the flux being capped at 10 gfd (during winter ADF conditions), and new membrane tanks to be constructed where the existing clarifiers are currently located.

## 1.1 influent flow data

The two influent design conditions are summarized in the tables below.

<b>alternative 2</b>		
minimum average day flow (min ADF)	91.3	mgd
average day flow (ADF)	138	mgd
maximum month flow (MMF)	198	mgd
maximum week flow (MWF)	300	mgd
maximum flow with one train offline for maintenance or cleaning (for 7 consecutive days)	300	mgd

<b>alternative 3</b>		
minimum average day flow (min ADF)	35	mgd
average day flow (ADF)	65.9	mgd
maximum month flow (MMF)	68.8	mgd
maximum week flow (MWF)	70	mgd
maximum flow with one train offline for maintenance or cleaning (for 30 consecutive days)	68.8	mgd

- min ADF - the average flow rate occurring over a 24-hour period during summer months.
- ADF – the average flow rate occurring over a 24-hour period based on annual flow rate data.
- MMF – the average flow rate occurring over a 24-hour period during the 30-day period with the highest flow based on annual flow rate data.
- MWF – the average flow rate occurring over a 24-hour period during the 7-day period with the highest flow based on annual flow rate data.

## 1.2 influent quality

Below are the ultrafiltration system influent characteristics that were used for this design; any deviation from the values below may impact the membrane system design.

<b>properties of mixed liquor entering membrane tanks</b>	<b>acceptable operating range</b>
Temperature range (°C)	11 - 20
MLSS concentration in membrane tanks (mg/L)	≤ 10,000 <sup>1</sup>
pH (SU)	6.5 – 7.5

soluble cBOD <sub>5</sub> concentration (mg/L)	≤ 5
NH <sub>3</sub> -N concentration (mg/L)	≤ 1.0
colloidal TOC (cTOC) concentration (mg/L) <sup>2</sup>	≤ 10
soluble alkalinity (mg/L as CaCO <sub>3</sub> )	50 – 150
time to filter (TTF) <sup>3</sup>	≤ 200 seconds
material greater than 2 mm in size (mg/L) <sup>4</sup>	≤ 1

note 1: Membrane tank MLSS concentration of up to 12,000 mg/L is permissible during MDF and PHF events only. Membrane tanks MLSS concentration to be ≤10,000 mg/L during all other flow conditions. There is no minimum concentration requirement.

note 2: Colloidal TOC (cTOC) is the difference between the TOC measured in the filtrate passing through a 1.5-µm filter paper and the TOC measured in the ZeeWeed membrane permeate.

note 3: Per seller’s standard time to filter (TTF) procedure (available upon request).

note 4: Per seller’s standard sieve test procedure (available upon request).

note 5: Chemicals that are not compatible with the ZeeWeed PVDF membrane are not permitted in the membrane tanks.

### 1.3 influent variability

Influent wastewater flows or loads in excess of the design criteria defined above will be bypassed.

### 1.4 effluent quality

The following performance parameters are expected based on the data listed in sections 1.1 and 1.2.

TSS	≤ 5	mg/L
turbidity	≤ 1	NTU



## 2 system design and scope

The membrane bioreactor (MBR) process consists of a suspended growth biological reactor integrated with a membrane filtration system, using the ZeeWeed hollow fiber ultrafiltration membrane. SUEZ is providing only the membrane filtration system design in this proposal, while the biological design is by others. The membrane filtration system essentially replaces the solids separation function of secondary clarifiers and tertiary sand filters used in a conventional activated sludge process.

ZeeWeed ultrafiltration membranes are directly immersed in mixed liquor. Using a permeate pump, a vacuum is applied to a header pipe connected to the membranes. The vacuum draws the treated water through the hollow fiber membranes. Permeate is then directed to downstream disinfection or discharge facilities. Air, in the form of large bubbles, is introduced below the bottom of the membrane modules, producing turbulence that scours the outer surface of the hollow fibers to keep them clean.

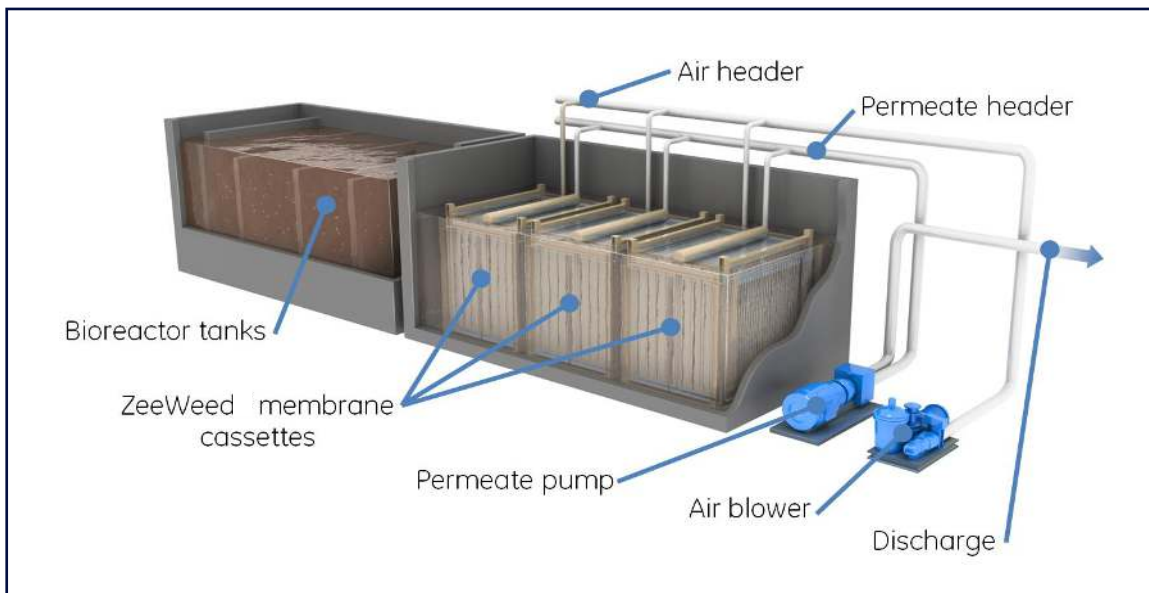

The proposed MBR design utilizes LEAPmbr, SUEZ’s latest technology for wastewater treatment. The use of LEAPmbr offers some of the most important benefits of a ZeeWeed MBR systems – simplicity, reliability, and lowest life-cycle cost.

### simplicity

Over the years, SUEZ has continually improved the design of ZeeWeed MBR systems, making them the simplest MBR systems in the industry to operate and maintain. The membrane filtration system for the West Point MBR is fully automated, with operators having the ability to review operation, adjust set points, or schedule operating tasks through the easy-to-understand HMI graphical display.

**A fully automated suite of membrane maintenance procedures** will ensure long-term, successful operation, including:

- in situ chemical membrane cleaning performed directly in the membrane tanks so your operators don't waste time moving cassettes;
- the ability to increase or decrease the frequency of maintenance cleans to fit the operating conditions;
- the ability to backpulse when needed to greatly improve your operator's ability to recover from non-design conditions.

The above cleaning systems are automated resulting in operators having available a full suite of comprehensive cleaning systems which are simple to use and initiate.

### **reliability**

SUEZ's reinforced ZeeWeed hollow fiber membrane incorporates a patented internal support to which the membrane is bonded, creating the most robust membrane in the industry. In addition, SUEZ's automated manufacturing processes ensure a consistent membrane product meeting the highest standards of workmanship and quality. This exceptionally strong and reliable membrane forms the backbone of ZeeWeed MBR systems, which consistently exceeds the toughest regulatory standards around the world.

SUEZ is the world leader in MBR technology, with the majority of the industry's largest and longest-operating MBR plants. SUEZ now has over two decades of experience with the well-proven ZeeWeed membrane. The earliest MBR plants using the ZeeWeed 500 membrane, SUEZ's current standard for MBR applications, have now been in operation for over 10 years. SUEZ's long-term and wide-ranging MBR experience ensures that plant operators can count on many years of successful operation of the proposed ZeeWeed MBR plant.

### **lowest lifecycle cost**

LEAPmbr aeration is a significant innovation for ZeeWeed MBR technology that offers a 30% reduction in air flow versus SUEZ's previous air cycling technology. When combined with LEAPmbr's other features, membrane aeration energy savings are almost 50% compared with the previous generation of ZeeWeed membranes. In addition to the substantial energy savings, LEAPmbr requires fewer membrane modules and cassettes, smaller membrane tanks, fewer valves and pipes, and lower connected horsepower. In many cases, a ZeeWeed MBR system using LEAPmbr technology has an equivalent lifecycle cost to conventional treatment options.

## **2.1 ultrafiltration system design**

The tables below outline possible designs for the West Point WWTP for the alternative 2 and 3 flow scenarios. These designs were developed based on the available information received from Brown and Caldwell and are subject to change pending more detailed information. Ultimately, SUEZ would work alongside King County and the design engineer to determine the best possible design for the West Point WWTP. Our system can be designed in many configurations, utilizing larger or smaller train sizes to fit the site space requirements as needed.

### **2.1.1 alternative 2**

The membrane designs for alternative 2 are shown in the table below. One design is for the flux cap of 10 gfd, while the other is for SUEZ's standard design flux.

flux	design flux <sup>1</sup>	10 gfd
number of membrane trains	32	58
number of cassette spaces per train	32	32
number of rows of cassettes per train	2	2
number of cassettes installed per train	28	28
type of cassette (number of modules)	52	52
module design per train	24 x 52 + 4 x 36 + 4 x 0	24 x 52 + 4 x 36 + 4 x 0
total number of modules installed per train	1,392	1,392
total number of modules installed per plant	44,160	80,736
membrane surface area	16,339,200 ft <sup>2</sup>	29,872,320 ft <sup>2</sup>
Total volume displaced by membranes	391,168 gal	708,992 gal
total number of cassettes installed per plant	896	1,456
spare space	16.3 %	16.3 %
membrane tank internal dimensions (L x W x H) <sup>2</sup>	103.3 x 20 x 13 ft	103.3 x 20 x 13 ft
total membrane tank volume <sup>2</sup>	6,428,730 gal	11,652,075 gal

note 1: based on SUEZ's standard design flux for the ZeeWeed 500d membrane at 11C.

note 2: Tank dimensions and volumes are preliminary only and may change once final detail design commences.

note 3: The ultrafiltration system is designed for installation within concrete tanks supplied by buyer.

### 2.1.2 alternative 3

The membrane designs for alternative 3 are shown in the table below. One design is for the flux cap of 10 gfd, while the other is for SUEZ's standard design flux.

flux	design flux <sup>1</sup>	10 gfd
number of membrane trains	10	16
number of cassette spaces per train	28	24
number of rows of cassettes per train	2	2
number of cassettes installed per train	26	22
type of cassette (52-module)	52	52
module design per train	24 x 52 + 2 x 40 + 2 x 0	22 x 52 + 2 x 0
total number of modules installed per train	1,328	1,144

total number of modules installed per plant	13,280	18,304
membrane surface area	4,913,600 ft <sup>2</sup>	6,772,480 ft <sup>2</sup>
volume displaced by membranes	115,580 gal	158,400 gal
total number of cassettes installed per plant	260	352
spare space	8.8 %	8.3 %
membrane tank internal dimensions (L x W x H) <sup>2</sup>	90.7 x 20 x 13 ft	78 x 20 x 13 ft
total membrane tank volume <sup>2</sup>	1,763,934 gal	2,427,110 gal

note 1: based on SUEZ's standard design flux for the ZeeWeed 500d membrane at 11C.

note 2: Tank dimensions and volumes are preliminary only and may change once final detail design commences.

note 3: The ultrafiltration system is designed for installation within concrete tanks supplied by buyer.

## 2.2 estimated membrane scour airflow

The table below contains estimates for the require membrane scour air flow for each condition. Air flow requirements are based on ADF flow conditions.

<del>alternative 2</del>	<del>91,616 scfm</del>
alternative 2 – 10 gfd flux cap	182,232 scfm
<del>alternative 3</del>	<del>27,280 scfm</del>
alternative 3 – 10 gfd flux cap	37,584 scfm

## 2.3 scope of supply by SUEZ

SUEZ's scope of supply for a ZeeWeed 500 membrane wastewater treatment system, for the West Point WWTP project is as follows.

- Electrical rating on all motors is 460V / 3ph / 60 Hz. Large motors may require higher voltage. Single phase power requirement is 120V.
- All proposed equipment and instrumentation quoted is to be installed in a NFPA 820 non-classified area.
- All devices will be SUEZ standard devices and the proposed equipment will be supplied to SUEZ specifications.
- Equipment will be **supplied loose-shipped** unless otherwise noted.

### ZeeWeed membranes and associated equipment

- ZeeWeed 500 membrane cassettes and modules
- membrane tank cassette mounting assemblies
- permeate collection & air distribution header pipes
- membrane tank level transmitters, one per membrane tank

- membrane tank level switches, one set per tank

#### **process pumping system**

- permeate pumps supplied loose, complete with required isolation valves, pressure gauges, and flow meters, one set per membrane train
- vacuum ejectors and associated valves, one per membrane train
- pressure transmitters for measure of transmembrane pressure, one per membrane train
- turbidimeters, one per membrane train

#### **membrane air scour blowers**

- common membrane air scour blowers supplied loose, complete with required isolation valves, pressure gauges and flow switches and acoustic enclosures

#### **backpulse system**

- backpulse pumps supplied loose, complete with required isolation valves, check valves, switches and flow meter

#### **mixed liquor recirculation**

- mixed liquor recirculation pumps used to transfer mixed liquor from membrane tanks to bioreactor, supplied loose, complete with required isolation valves and check valves, pressure gauges, and flow meters

#### **membrane cleaning systems**

- sodium hypochlorite chemical feed system
- citric acid chemical feed system

#### **electrical and control equipment**

- master control panel containing PLC and touch screen HMI

#### **miscellaneous**

- air compressors and refrigerated air dryers for ejectors and pneumatic valves operation

#### **general**

- equipment layout, membrane tank general arrangement and process and instrumentation drawings
- operating & maintenance manuals
- field service and start-up assistance - 200 days support from SUEZ water field-service personnel for installation assistance, commissioning, plant start-up and operator training
- membrane warranty – 2 years

- equipment mechanical warranty – 1 year or 18 months from shipment of equipment
- InSight Pro – process consulting service and 24/7 emergency telephone technical support service – 1 year

### 3 buyer scope of supply

The following items are for supply by buyer and will include but are not limited to:

- overall plant design responsibility
- review and approval of design parameters related to the membrane separation system
- review and approval of SUEZ-supplied tank and equipment drawings and specifications
- detail drawings of all termination points where SUEZ equipment or materials tie into equipment or materials supplied by buyer
- design, supply and installation of lifting devices including overhead traveling bridge crane and/or monorail able to lift 4,535 kg (10,000 lb) for membrane removal, lifting davits c/w a hoist, guide rails for submersible mixers and pumps etc.
- civil works, provision of main plant tank structure, buildings, equipment foundation pads etc. including but not limited to:
  - common channels, housekeeping pads, equipment access platforms, walkways, handrails, stairs, etc.
- membrane tanks, tank covers or grating, and their support over membrane tanks.
- HVAC equipment design, specifications and installation (where applicable)
- UPS, power conditioner, emergency power supply and specification (where applicable)
- 2-mm pre-treatment fine screens
- biological process equipment – including process blowers, diffusers and mixers
- VFDs and MCC for all SUEZ supplied equipment
- plant SCADA system
- process and utilities piping, pipe supports, hangers, valves, etc. including but not limited to:
  - piping, pipe supports and valves between SUEZ-supplied equipment and other plant process equipment
  - piping between any loose-supplied SUEZ equipment
  - process tank aeration system air piping, equalization tank system piping, etc.
- electrical wiring, conduit and other appurtenances required to provide power connections as required from the electrical power source to the SUEZ control panel and from the control panel to any electrical equipment, pump motors and instruments external to the SUEZ-supplied enclosure

- supply and installation of suitable, secure remote internet connection for 24/7 emergency telephone technical support service and InSight remote monitoring & diagnostics service
- design, supply and installation of equipment anchor bolts and fasteners for SUEZ supplied equipment. All seismic structural analysis and anchor bolt sizing.
- receiving (confirmation versus packing list), unloading and safe storage of SUEZ-supplied equipment at site until ready for installation
- installation on site of all SUEZ supplied loose-shipped equipment
- alignment of rotating equipment
- raw materials, chemicals, and utilities during equipment start-up and operation
- disposal of initial start-up wastewater and associated chemicals
- supply of seed sludge for biological process start-up purposes
- laboratory services, operating and maintenance personnel during equipment checkout, start-up and operation
- touch up primer and finish paint surfaces on equipment as required at the completion of the project
- weather protection as required for all SUEZ-supplied equipment. Skids and electrical panels are designed for indoor operation and will need shelter from the elements.



## 4 commercial

### 4.1 pricing

Pricing for the proposed equipment and services, as outlined in section 2.3, is summarized in the table below. All pricing is based on the design operating conditions and influent characteristics detailed in section 1 based on SUEZ' recommended design flux and also for a specified flux cap of 10 gfd. Alternative 2 (300 mgd) pricing is given for installation within new membrane tanks. Alternative 3 (70 mgd) pricing is given for installation within new membrane tanks. The pricing herein is for budgetary purposes only and does not constitute an offer of sale. No sales, consumer use or other similar taxes or duties are included in the pricing below.

<b>price: all equipment &amp; service (all pricing in USD)</b>	
<del>alternative 2</del>	<del>\$ 85,086,000</del>
alternative 2 – 10 gfd flux cap	\$ 116,050,000
<del>alternative 3</del>	<del>\$ 25,674,000</del>
alternative 3 – 10 gfd flux cap	\$ 35,031,000

### 4.2 annual chemical consumption estimate

	<b>US gal/year</b>
<b>alternative 2</b>	
sodium hypochlorite (10.3% w/w, SG: 1.168)	211,647
citric acid (50.0% w/w, SG: 1.24)	26,660
<b>alternative 2 – 10 gfd flux cap</b>	
sodium hypochlorite (10.3% w/w, SG: 1.168)	383,611
citric acid (50.0% w/w, SG: 1.24)	48,320
<b>alternative 3</b>	
sodium hypochlorite (10.3% w/w, SG: 1.168)	61,362
citric acid (50.0% w/w, SG: 1.24)	7,274
<b>alternative 3 – 10 gfd flux cap</b>	
sodium hypochlorite (10.3% w/w, SG: 1.168)	84,135
citric acid (50.0% w/w, SG: 1.24)	9,855

note 1: Cleaning chemical consumption estimates are based on the frequencies and concentrations summarized in the table below. Frequencies are typical for ZW-MBR operation, actual frequency of maintenance and recovery cleans may change with final design or may change once system is in operation.

#### basis of chemical consumption estimates

<b>chemical</b>		<b>maintenance clean</b>	<b>recovery clean</b>
sodium hypochlorite solution (10.3% w/w, SG: 1.168)	frequency	2 times per week	2 times per year
	concentration	200 mg/L	1,000 mg/L

citric acid solution (50.0% w/w, SG: 1.24)	frequency	n/a	2 times per year
	concentration	n/a	2,000 mg/L

### 4.3 equipment shipment and delivery

Equipment shipment is estimated at 28 to 37 weeks after order acceptance. The buyer and seller will arrange a kick-off meeting after contract acceptance to develop a firm shipment schedule.

#### typical drawing submission and equipment shipment schedule

	8-12 weeks	2-3 weeks	16-20 weeks	2 weeks
acceptance of PO				
submission of drawings				
drawings approval				
equipment manufacturing				
equipment shipment				
plant operations manuals				

The delivery schedule is presented based on current workload backlogs and production capacity. This estimated delivery schedule assumes no more than 2 weeks for buyer review of submittal drawings. Any delays in buyer approvals or requested changes may result in additional charges and/or a delay to the schedule.

### 4.4 freight terms

The following freight terms used are as defined by INCOTERMS 2010.

All pricing is CIP to West Point WWTP project site.

### 4.5 terms and conditions of sale

This proposal has been prepared and is submitted based on seller’s standard terms and conditions of sale.

## WEST POINT WWTP, WA

### AnammoPAQ® System

## PREPARED FOR

---

**Brown and Caldwell**

Matt Winkler

[mwinkler@brwncald.com](mailto:mwinkler@brwncald.com)

## AREA REPRESENTATIVE

---

**Goble Sampson**

Douglas Allie

[dallie@goblesampson.com](mailto:dallie@goblesampson.com)

## PREPARED BY

Mudit Gangal

Phone: (512)-834-6042

[mudit.gangal@ovivowater.com](mailto:mudit.gangal@ovivowater.com)

**Ovivo USA, LLC**

2404 Rutland Drive

Austin, Texas, 78758, USA



September 6, 2019

Attn: Mr. Matt Winkler  
Brown and Caldwell.

Re: West Point WWTP, WA  
Ovivo AnammoPAQ® System  
Proposal No. 090619-1-MG-R0

Dear Mr. Winkler,

With regard to your recent request for the West Point WWTP, WA, Ovivo USA, LLC is pleased to submit this preliminary proposal for its AnammoPAQ® system. The system design is based on the influent high nitrogen stream at the West Point WWTP, WA having design flows for 4 alternatives mentioned in below Table 1 to achieve approximately 80% Ammonia-N removal. It may be noted that the design for the AnammoPAQ® system for Alternatives 1, 2B/2C and 3A remains the same (Design 1) while a separate design (Design 2) is provided for smaller Alternative 4B/4D.

It is assumed that the dewatering will occur 24 hours a day and 7 days a week with AnammoPAQ® system operation 7 days a week. It is also assumed enough equalization (and dilution water particularly for peak day scenarios) will be provided (by others) and all equipment in the equalization tank including feed pumps will be by others.

We have endeavored to provide complete information in this proposal. However, if you have any questions or need additional information, please feel free to contact Doug our regional sales representative, or me directly.

Sincerely,

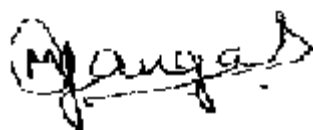

**Mudit Gangal**  
**Product Group Manager**  
**Biosolids Management and Resource Recovery**  
**Ovivo USA, LLC**  
2404 Rutland Drive, Austin, Texas 78758  
**P: 512-834-6042 C: 512-590-0391 F: 512-834-6039**



© Copyright 2019 OVIVO. All rights reserved.

This document is confidential and shall remain the sole property of Ovivo. This document may not be reproduced or distributed without prior written approval of Ovivo. The data and information provided is furnished on a restricted basis and is not to be used in any way detrimental to the interests of Ovivo.

THIS BUDGETARY PROPOSAL CONSTITUTES A NON-BINDING ESTIMATE OF PRICE(S) FOR CERTAIN GOODS AND/OR SERVICES THAT MAY BE PROVIDED BY OVIVO USA LLC FROM TIME TO TIME, BUT SHALL NOT BE CONSTRUED AS A CONTRACTUAL OFFER FOR OVIVO USA LLC TO PROVIDE SUCH GOODS AND/OR SERVICES. ANY CONTRACTUAL OFFER FOR THE SUPPLY OF GOODS AND/OR SERVICES BY OVIVO USA LLC SHALL BE CONVEYED TO CUSTOMER IN THE FORM OF OVIVO USA LLC'S STANDARD PROPOSAL DOCUMENT, WHICH INCLUDES, BUT IS NOT LIMITED TO, ITS STANDARD TERMS AND CONDITIONS OF SALE. SUCH PROPOSAL FORM MAY BE PROVIDED TO CUSTOMER UPON REQUEST.

## INTRODUCTION

The West Point WWTP, WA is in the process of evaluating technologies for treatment of its high Nitrogen content side-stream to reduce the Ammonia-N load to help meet its effluent permits in an efficient manner. The design flows and loads required to be treated by using the AnammoPAQ® treatment process to reduce the Ammonia-N concentration in the effluent stream being discharged to more acceptable limits are provided in Table 1 below.

## BASIS OF DESIGN

The AnammoPAQ® system design and performance are based on the design information provided by Brown and Caldwell. Table 1 summarizes the parameters used for developing the proposed solution.

Treatment Parameter	Units	Alternate 1	Alternate 2B/2C	Alternate 3A	Alternate 4B/4C	Treated Effluent
Equalized Design Flow (Peak Month)	MGD	0.409	0.436	0.496	0.204	
Flow Rate (Peak Day) <sup>1</sup>	MGD	0.60	0.65	0.75	0.30	
Temperature	°C	25-30	25-30	25-30	25-30	
TKN	mg/l	1,485	1,485	1,485	1,485	
NH <sub>3</sub> -N	mg/l	1,337	1,337	1,337	1,337	267
Alkalinity	mg/l	4,677	4,677	4,677	4,677	
TP	mg/l	< 90	< 90	< 90	< 90	
TSS	mg/l	< 500	< 500	< 500	< 500	
BOD	mg/l	171	171	171	171	
COD	mg/l	< 800	< 800	< 800	< 800	
pH		7-8	7-8	7-8	7-8	

The design is based on the following assumption(s):

- The influent flows are produced seven (7) days a week, twenty-four (24) hours a day.
- Given the high influent TP and COD, it is recommended to have pre-treatment (by others) to ensure optimal process performance. Suggested pre-treatment system for the above is the Ovivo-Paques PhospaQ™ system for which we would be happy to provide information on upon request.

© Copyright 2019 OVIVO. All rights reserved.

This document is confidential and shall remain the sole property of Ovivo. This document may not be reproduced or distributed without prior written approval of Ovivo. The data and information provided is furnished on a restricted basis and is not to be used in any way detrimental to the interests of Ovivo.

THIS BUDGETARY PROPOSAL CONSTITUTES A NON-BINDING ESTIMATE OF PRICE(S) FOR CERTAIN GOODS AND/OR SERVICES THAT MAY BE PROVIDED BY OVIVO USA LLC FROM TIME TO TIME, BUT SHALL NOT BE CONSTRUED AS A CONTRACTUAL OFFER FOR OVIVO USA LLC TO PROVIDE SUCH GOODS AND/OR SERVICES. ANY CONTRACTUAL OFFER FOR THE SUPPLY OF GOODS AND/OR SERVICES BY OVIVO USA LLC SHALL BE CONVEYED TO CUSTOMER IN THE FORM OF OVIVO USA LLC'S STANDARD PROPOSAL DOCUMENT, WHICH INCLUDES, BUT IS NOT LIMITED TO, ITS STANDARD TERMS AND CONDITIONS OF SALE. SUCH PROPOSAL FORM MAY BE PROVIDED TO CUSTOMER UPON REQUEST.

- Dilution water (up to 50,000 gpd) will be provided (by others) for Peak Day conditions

The West Point WWTP, WA AnammoPAQ® system was designed using extensive modeling and experience from Ovivo's pilot and full-scale installations. The modeling assists in process selection and determining the optimal volumes for treatment and the overall process operating parameters.

## OVIVO-PAQUES ANAMMOPAQ® EXPERIENCE

The Ovivo-Paques AnammoPAQ® system currently has over 50 operating nitrogen removal deammonification systems worldwide including North America. Further, Ovivo's AnammoPAQ® installation base cumulatively treats globally Nitrogen loads in excess of 250,000 lbs N/d, which is second to none. This is estimated to be around 80% of all Ammonia-N load currently treated in engineered systems utilizing anammox bacteria worldwide.



**Figure:1 Modular AnammoPAQ® setup at Rendac, The Netherland (13,000 lds N/day)**

## TREATMENT APPROACH

In the AnammoPAQ<sup>®</sup> reactor, ammonium is converted to nitrogen gas. The reaction is executed by two different bacteria, which coexist in the reactor. Ammonium oxidizing bacteria (AOB) oxidize about half of the ammonium to nitrite. Anammox bacteria then convert the remaining ammonium and nitrite, into nitrogen gas. The overall reaction of the one step AnammoPAQ<sup>®</sup> reactor is:

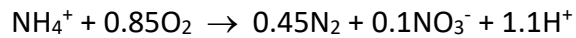

The deammonification conversion thus is an elegant shortcut in the natural nitrogen cycle. A key feature of the AnammoPAQ<sup>®</sup> system is that ammonium is removed from the reject water stream in one treatment step without the use of external carbon sources and with minimal energy input.

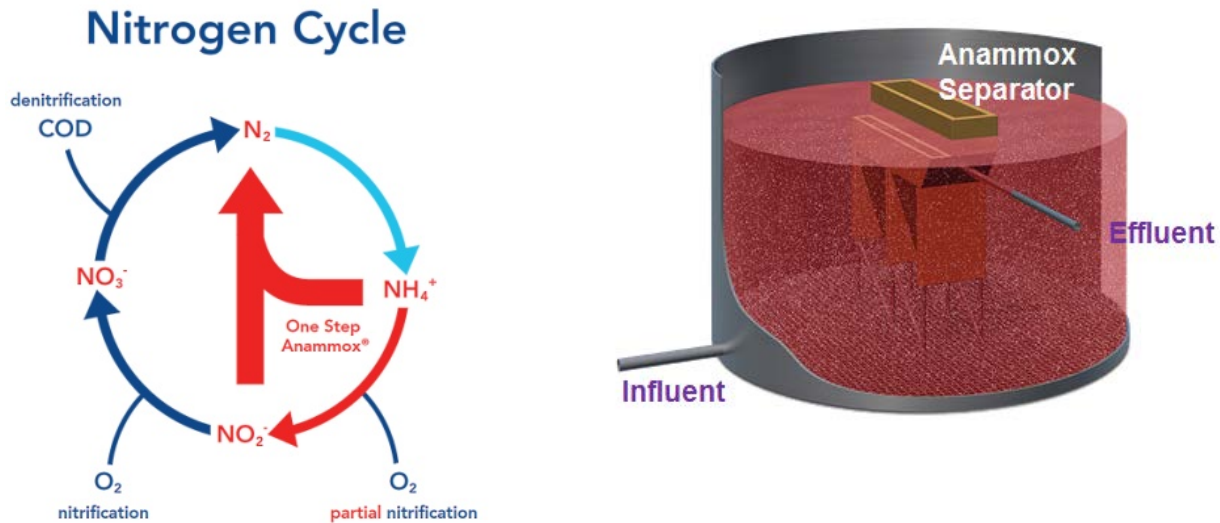

The AnammoPAQ<sup>®</sup> reactor is a continuously fed and aerated tank, equipped with Ovivo's patented biomass retention system. The aeration provides for rapid mixing of the influent with the reactor content, intense contact with the biomass and oxygen supply to drive the conversion. This process is based on granular biomass. The aeration is controlled in order to selectively convert ammonium to nitrogen gas. Around 10% of the ammonium is converted into nitrate. The treated wastewater leaves the reactor via the biomass retention system at the top of the reactor.

The granular biomass is separated from the cleaned wastewater, assuring high biomass content in the reactor. Together with the dense conversion properties typical for granular biomass, the high biomass content provides for high loading/conversion rates and therefore a small reactor volume.

© Copyright 2019 OVIVO. All rights reserved.

This document is confidential and shall remain the sole property of Ovivo. This document may not be reproduced or distributed without prior written approval of Ovivo. The data and information provided is furnished on a restricted basis and is not to be used in any way detrimental to the interests of Ovivo.

THIS BUDGETARY PROPOSAL CONSTITUTES A NON-BINDING ESTIMATE OF PRICE(S) FOR CERTAIN GOODS AND/OR SERVICES THAT MAY BE PROVIDED BY OVIVO USA LLC FROM TIME TO TIME, BUT SHALL NOT BE CONSTRUED AS A CONTRACTUAL OFFER FOR OVIVO USA LLC TO PROVIDE SUCH GOODS AND/OR SERVICES. ANY CONTRACTUAL OFFER FOR THE SUPPLY OF GOODS AND/OR SERVICES BY OVIVO USA LLC SHALL BE CONVEYED TO CUSTOMER IN THE FORM OF OVIVO USA LLC'S STANDARD PROPOSAL DOCUMENT, WHICH INCLUDES, BUT IS NOT LIMITED TO, ITS STANDARD TERMS AND CONDITIONS OF SALE. SUCH PROPOSAL FORM MAY BE PROVIDED TO CUSTOMER UPON REQUEST.



## AnammoPAQ® PROCESS ADVANTAGES

Main benefits of implementing the AnammoPAQ® system for Nitrogen removal are the significant savings on operational costs and environmental impact compared to conventional and alternative deammonification systems. These include:

- Aeration Energy Savings (over 60%)
- Elimination of external Carbon source (100% saving)
- Reduction in sludge production (up to 90%)
- Compact footprint
- High Loading Rates
- Reduction in CO2 emission
- Limited chemical consumption
- Fast start up due to inoculation with granular biomass
- Robust process: Tolerant to presence of toxic chemicals
- Ability to handle high suspended solids in influent

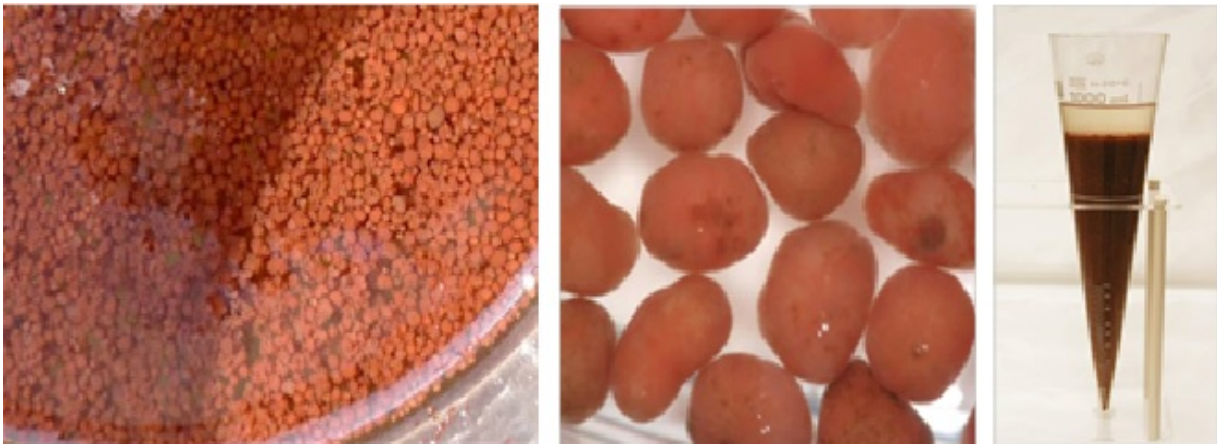

**Anammox Granular Biomass**

© Copyright 2019 OVIVO. All rights reserved.

This document is confidential and shall remain the sole property of Ovivo. This document may not be reproduced or distributed without prior written approval of Ovivo. The data and information provided is furnished on a restricted basis and is not to be used in any way detrimental to the interests of Ovivo.

THIS BUDGETARY PROPOSAL CONSTITUTES A NON-BINDING ESTIMATE OF PRICE(S) FOR CERTAIN GOODS AND/OR SERVICES THAT MAY BE PROVIDED BY OVIVO USA LLC FROM TIME TO TIME, BUT SHALL NOT BE CONSTRUED AS A CONTRACTUAL OFFER FOR OVIVO USA LLC TO PROVIDE SUCH GOODS AND/OR SERVICES. ANY CONTRACTUAL OFFER FOR THE SUPPLY OF GOODS AND/OR SERVICES BY OVIVO USA LLC SHALL BE CONVEYED TO CUSTOMER IN THE FORM OF OVIVO USA LLC'S STANDARD PROPOSAL DOCUMENT, WHICH INCLUDES, BUT IS NOT LIMITED TO, ITS STANDARD TERMS AND CONDITIONS OF SALE. SUCH PROPOSAL FORM MAY BE PROVIDED TO CUSTOMER UPON REQUEST.



## AnammoPAQ® PROCESS DESIGN

The systems for the West Point WWTP, WA has been designed using proprietary models to perform process selection and to determine essential operating parameters.

A summary of the AnammoPAQ® system designs is provided in Table 2. This table demonstrates the volumes required to achieve desired effluent Ammonia-N reduction, and provides associated process design details.

Table 2. Design Summary

Design		Design 1		Design 2	
Treatment Parameter	Unit	Alternate - 1, 2B/2C, 3A	Alternate - 1, 2B/2C, 3A (Peak Day)	Alternate - 4B/4D	Alternate - 4B/4D (Peak Day)
Equalized Design Flow	MGD	0.409 to 0.496	0.409 to 0.496	0.204	0.204
Total No. of AnammoPAQ® Reactors	#	1	2	1	2
Volume of AnammoPAQ® Reactor (each)	Gallons	375,000	375,000	156,000	156,000
Length of AnammoPAQ® Reactor (each)	ft	50	50	32.3	32.3
Width of AnammoPAQ® Reactor (each)	ft	50	50	32.3	32.3
SWD of AnammoPAQ® Reactor	ft	20	20	20	20
Foot print	ft <sup>2</sup>	2,500	5,000	1,043	2,086
Air Flow for AnammoPAQ® Reactor (each)	scfm	2,600	2,600	1,100	1,100

© Copyright 2019 OVIVO. All rights reserved.

This document is confidential and shall remain the sole property of Ovivo. This document may not be reproduced or distributed without prior written approval of Ovivo. The data and information provided is furnished on a restricted basis and is not to be used in any way detrimental to the interests of Ovivo

THIS BUDGETARY PROPOSAL CONSTITUTES A NON-BINDING ESTIMATE OF PRICE(S) FOR CERTAIN GOODS AND/OR SERVICES THAT MAY BE PROVIDED BY OVIVO USA LLC FROM TIME TO TIME, BUT SHALL NOT BE CONSTRUED AS A CONTRACTUAL OFFER FOR OVIVO USA LLC TO PROVIDE SUCH GOODS AND/OR SERVICES. ANY CONTRACTUAL OFFER FOR THE SUPPLY OF GOODS AND/OR SERVICES BY OVIVO USA LLC SHALL BE CONVEYED TO CUSTOMER IN THE FORM OF OVIVO USA LLC'S STANDARD PROPOSAL DOCUMENT, WHICH INCLUDES, BUT IS NOT LIMITED TO, ITS STANDARD TERMS AND CONDITIONS OF SALE. SUCH PROPOSAL FORM MAY BE PROVIDED TO CUSTOMER UPON REQUEST.

## SCOPE

### SCOPE OF SUPPLY

The following table outlines the Ovivo AnammoPAQ® system scope of supply for the proposed project.

Scope of Supply		
Item	Qty	Description
<b>Design 1 – For Alternate – 1, 2B/2C, 3A</b>		
1	2	AnammoPAQ® reactor <u>internals</u> (suitable for each 375,000-Gal tank – tank by others) <ul style="list-style-type: none"> <li>• 1 x Type 33 Settler and support construction</li> <li>• Fine Bubble aeration system with Aerostrip® diffusers, basin piping for c/w drop legs, flanged diffuser pipes, mounting brackets and connection fasteners</li> <li>• Piping for aeration, influent, effluent, biomass sampling</li> </ul>
2	3 (2+1)	Process Air Blowers for AnammoPAQ® with VFD; Capacity: 2,600 scfm each
3	Lot	Anammox granular biomass
4	Lot	Controls and Instrumentation (NH <sub>4</sub> <sup>+</sup> , NO <sub>3</sub> <sup>-</sup> , NO <sub>2</sub> <sup>-</sup> , DO, pH, T)
<b>Design 2 – For Alternate – 4B/4D</b>		
1	2	AnammoPAQ® reactor <u>internals</u> (suitable for each 156,000-Gal tank – tank by others) <ul style="list-style-type: none"> <li>• 1 x Type 17 Settler and support construction</li> <li>• Fine Bubble aeration system with Aerostrip® diffusers, basin piping for c/w drop legs, flanged diffuser pipes, mounting brackets and connection fasteners</li> <li>• Piping for aeration, influent, effluent, biomass sampling</li> </ul>
2	3 (2+1)	Process Air Blowers for AnammoPAQ® with VFD; Capacity: 1,100 scfm each
3	Lot	Anammox granular biomass
4	Lot	Controls and Instrumentation (NH <sub>4</sub> <sup>+</sup> , NO <sub>3</sub> <sup>-</sup> , NO <sub>2</sub> <sup>-</sup> , DO, pH, T)
<b>Scope Common to Both Designs</b>		
5	2	Sets of O&M Manuals
6	2	Sets of Detailed Shop Drawings
7	20	Service Days, to inspect equipment installation, test all supplied components, assist in start-up and train plant personnel.

© Copyright 2019 OVIVO. All rights reserved.

This document is confidential and shall remain the sole property of Ovivo. This document may not be reproduced or distributed without prior written approval of Ovivo. The data and information provided is furnished on a restricted basis and is not to be used in any way detrimental to the interests of Ovivo

THIS BUDGETARY PROPOSAL CONSTITUTES A NON-BINDING ESTIMATE OF PRICE(S) FOR CERTAIN GOODS AND/OR SERVICES THAT MAY BE PROVIDED BY OVIVO USA LLC FROM TIME TO TIME, BUT SHALL NOT BE CONSTRUED AS A CONTRACTUAL OFFER FOR OVIVO USA LLC TO PROVIDE SUCH GOODS AND/OR SERVICES. ANY CONTRACTUAL OFFER FOR THE SUPPLY OF GOODS AND/OR SERVICES BY OVIVO USA LLC SHALL BE CONVEYED TO CUSTOMER IN THE FORM OF OVIVO USA LLC'S STANDARD PROPOSAL DOCUMENT, WHICH INCLUDES, BUT IS NOT LIMITED TO, ITS STANDARD TERMS AND CONDITIONS OF SALE. SUCH PROPOSAL FORM MAY BE PROVIDED TO CUSTOMER UPON REQUEST.

## ITEMS BY OTHERS

The following items are specifically not by Ovivo. They may or may not be required.

Items Not Included	
Air Main Piping and all accessories including valves, bolts gaskets and connectors for attaching to drop pipes	Yard Hydrants
Chemical Feed Systems for alkalinity correction, magnesium oxide, nutrients, methanol and defoamer	Mixers
Chemicals for operation: Including methanol, nutrients, alkaline solution, defoamer	Motor Control Center (MCC)
Cleanouts	Non-potable water supply
Concrete	Overflow structures including baffles and weir plates
Drains	Power
Dryers	Dilution Water
Engines/Generators	Pre-treatment systems for deammonification system (e.g. influent TSS removal system, Phosphorus removal system and COD removal system)
Equalization Tank and equipment therein	Sludge handling and disposal
Foam control	Support Platforms
Hoses /Bibs	Tanks (and modifications to tankage – existing or new)
Influent/Feed Pumps	Transformers
Interconnecting Piping	Valves – Manual and Automatic
Laboratory	Variable Frequency Drives for blowers and pumps
Ladders (caged or other types) and Handrails	Ventilation
Lighting	Walkways/Roofing/Stairs/Gratings/Handrails
Liquid sampling and analytical work	Wireways/Wiring
Local control panels for blowers etc.	Yard Piping

© Copyright 2019 OVIVO. All rights reserved.

This document is confidential and shall remain the sole property of Ovivo. This document may not be reproduced or distributed without prior written approval of Ovivo. The data and information provided is furnished on a restricted basis and is not to be used in any way detrimental to the interests of Ovivo

THIS BUDGETARY PROPOSAL CONSTITUTES A NON-BINDING ESTIMATE OF PRICE(S) FOR CERTAIN GOODS AND/OR SERVICES THAT MAY BE PROVIDED BY OVIVO USA LLC FROM TIME TO TIME, BUT SHALL NOT BE CONSTRUED AS A CONTRACTUAL OFFER FOR OVIVO USA LLC TO PROVIDE SUCH GOODS AND/OR SERVICES. ANY CONTRACTUAL OFFER FOR THE SUPPLY OF GOODS AND/OR SERVICES BY OVIVO USA LLC SHALL BE CONVEYED TO CUSTOMER IN THE FORM OF OVIVO USA LLC'S STANDARD PROPOSAL DOCUMENT, WHICH INCLUDES, BUT IS NOT LIMITED TO, ITS STANDARD TERMS AND CONDITIONS OF SALE. SUCH PROPOSAL FORM MAY BE PROVIDED TO CUSTOMER UPON REQUEST.

**ADDITIONAL ITEMS BY INSTALLING CONTRACTOR**

- 1 Obtain necessary construction permits and licenses, construction drawings (including interconnecting piping drawings) field office space, telephone service, and temporary electrical service.
- 2 All site preparation, grading, locating foundation placement, excavation for foundation, underground piping, conduits and drains.
- 3 Demolition and/or removal of any existing structures, equipment or facilities required for construction and installation of the AnammoPAQ® system.
- 4 Installation of all foundation - supply and installation of all embedded or underground piping, conduits and drains.
- 5 All backfill, compaction, finish grading, earthwork and final paving.
- 6 Receiving (preparation of receiving reports), unloading, storage, maintenance preservation and protection of all equipment and materials supplied by Ovivo.
- 7 Installation of all equipment and materials supplied by Ovivo.
- 8 Supply, fabrication, installation, cleaning, pickling and/or passivation of all interconnecting steel piping components.
- 9 Provide and install all embedded pipe sections and valves for tank drains and reactor inlets and elbows.
- 10 All cutting, welding, fitting and finishing for all field fabricated piping.
- 11 Supply and installation of all flange gaskets and bolts for all piping components.
- 12 Supply and installation of all pipe supports and wall penetrations.
- 13 Install and provide all motor control centers, motor starters, panels, field wiring, wireways, supports and transformers.
- 14 Install all control panels and instrumentation as supplied by Ovivo, as applicable.
- 15 Supply and install all electrical power and control wiring and conduit to the equipment served plus interconnection between the Ovivo equipment as required, including wire, cable, junction boxes, fittings, conduit, cable trays, safety disconnect switches, circuit breakers, etc.
- 16 Supply and install all insulation, supports, drains, gauges, hold down clamps, condensate drain systems, flanges, flex pipe joints, expansion joints, boots, gaskets, adhesives, fasteners, safety signs, and any specialty items such as traps.
- 17 All labor, materials, supplies and utilities as required for start-up including laboratory facilities and analytical work.
- 18 Provide all chemicals required for plant operation and all chemicals, lubricants, glycol, oils or grease and other supplies thereafter.

- 19 Install all anchor bolts and mounting hardware supplied by Ovivo; and supply and install all anchor bolts and mounting hardware not specifically supplied by Ovivo.
- 20 Provide all nameplates, safety signs and labels.
- 21 Provide all additional support beams and/or slabs.
- 22 Provide and install all manual valves.
- 23 Provide and install all piping required to interconnect to the Ovivo's equipment.
- 24 The Contractor shall coordinate the installation and timing of interface points such as piping and electrical with the Ovivo Supplier.

***All other necessary equipment and services not otherwise listed as specifically supplied by Ovivo.***

**BUDGET PRICE**

Our current budget estimate price for the AnammoPAQ® system, as described in this proposal is:

Description	Price
AnammoPAQ® system as described above – Design 1	<b>As Advised by Rep</b> <b>\$5,984,000</b>
AnammoPAQ® system as described above – Design 2	<b>As Advised by Rep</b> <b>\$3,632,000</b>

**NOTES –**

1. Our Price and Payment Terms are based on Ovivo's standard terms and conditions, which can be provided upon request.
2. This price will be valid for thirty (30) days.
3. All prices are excluding Washington state sales and use taxes and any federal taxes which shall be the sole responsibility of the Client. No additional duties will have to be paid for the equipment supplied by Ovivo.
4. Pricing is subject to the London Metal exchange index for stainless steel rolled coil calculated from the original proposal date and is in accordance with the Scope of Supply and terms of this proposal and any changes may require the price to be adjusted.

**Shipping Terms**

FOB Shipping Point, Full Freight Allowed

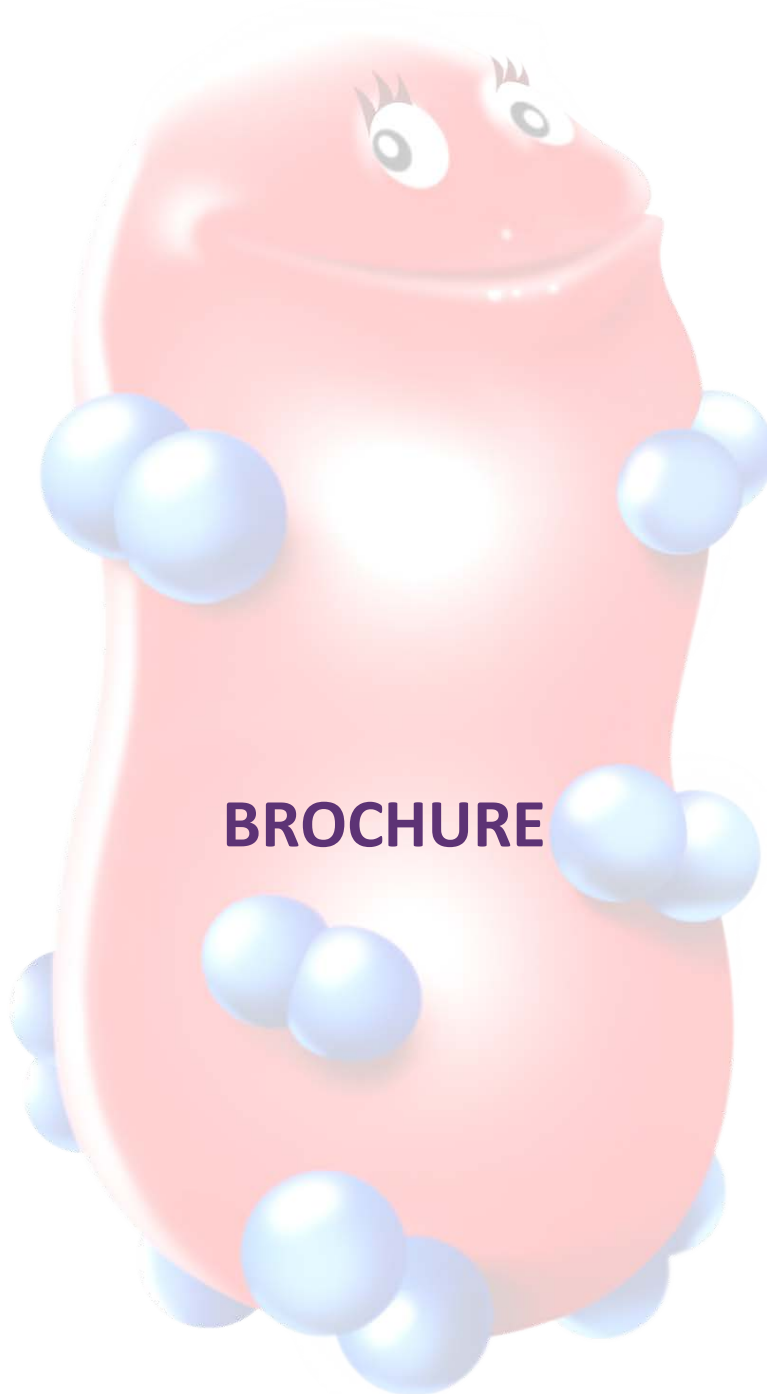

# BROCHURE

---

**© Copyright 2019 OVIVO. All rights reserved.**

This document is confidential and shall remain the sole property of Ovivo. This document may not be reproduced or distributed without prior written approval of Ovivo. The data and information provided is furnished on a restricted basis and is not to be used in any way detrimental to the interests of Ovivo

THIS BUDGETARY PROPOSAL CONSTITUTES A NON-BINDING ESTIMATE OF PRICE(S) FOR CERTAIN GOODS AND/OR SERVICES THAT MAY BE PROVIDED BY OVIVO USA LLC FROM TIME TO TIME, BUT SHALL NOT BE CONSTRUED AS A CONTRACTUAL OFFER FOR OVIVO USA LLC TO PROVIDE SUCH GOODS AND/OR SERVICES. ANY CONTRACTUAL OFFER FOR THE SUPPLY OF GOODS AND/OR SERVICES BY OVIVO USA LLC SHALL BE CONVEYED TO CUSTOMER IN THE FORM OF OVIVO USA LLC'S STANDARD PROPOSAL DOCUMENT, WHICH INCLUDES, BUT IS NOT LIMITED TO, ITS STANDARD TERMS AND CONDITIONS OF SALE. SUCH PROPOSAL FORM MAY BE PROVIDED TO CUSTOMER UPON REQUEST.

## OVIVO-PAQUES AnammoPAQ™ PROCESS

### SUSTAINABLE NITROGEN REMOVAL

#### HOW WE CREATE VALUE

Cost-effective nitrogen removal from digester sidestreams (with or without THP) using Anammox

Compared to conventional nitrification and denitrification:

- 60% energy savings compared
- 100% reduction in supplemental organic carbon
- 90% reduction in sludge production
- 90% reduction in footprint
- 85% reduction in CO<sub>2</sub> emissions

Quick startup time with potential for full process optimization within 3 weeks

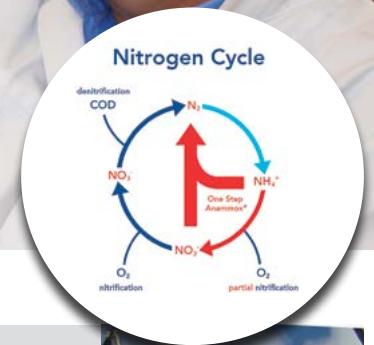

#### THE CHALLENGE

- Despite representing 1% to 3% of the flow to the mainstream, typical anaerobic digester sidestream contains 10% to 30% of the nitrogen load, with concentrations often in excess of 1,000 mg/L ammonia-N
- Sludge pre-treatment with THP can double the ammonia-N concentrations in the sidestream
- Stringent BNR limits on main stream
- Conventional nitrification and denitrification requires significant aeration energy and supplemental carbon

#### THE OVIVO SOLUTION

The AnammoPAQ™ process is an elegant shortcut in the natural nitrogen cycle. The process utilizes Anammox bacteria which directly convert ammonium (NH<sub>4</sub><sup>+</sup>) and nitrite (NO<sub>2</sub><sup>-</sup>) into nitrogen gas. Paques developed the original process for commercial purposes in cooperation with Delft University of Technology and the University of Nijmegen. Since the first full-scale plant started up in 2002 (treatment of sidestream from sludge digestion), many other plants have been installed and are running successfully.

#### The AnammoPAQ™ ADVANTAGE

- Proven technology with 15+ years operational experience
- 35+ AnammoPAQ™ references worldwide
- Largest single unit can handle 10 metric tons of nitrogen/day (equivalent to sidestream from a 250 MGD municipal plant)!
- Robust system, handling high loading variations
- Up to 60% saving on operational costs
- Savings on excess sludge production
- No addition of organic carbon source (methanol) required
- Production of valuable Anammox biomass
- High loading rates leading to compact footprint
- Lowest O&M amongst competing systems





## OPERATING PRINCIPLE

AnammoPAQ™ is a continuous flow reactor system in which nitrification and anammox conversion occur simultaneously in a single process unit. Anammox (anaerobic ammonium oxidation) conversion is an elegant short-cut in the natural nitrogen cycle where ammonium and nitrite are converted to nitrogen gas. As the Anammox process involves removal of ammonium over nitrite (NO<sub>2</sub><sup>-</sup>) rather than nitrate (NO<sub>3</sub><sup>-</sup>), 63% less oxygen (O<sub>2</sub>) is required while eliminating the need for an external carbon source altogether. Optimal process control ensures retention of AOBs and Anammox bacteria while eliminating NOBs, leading to stable & robust operation.

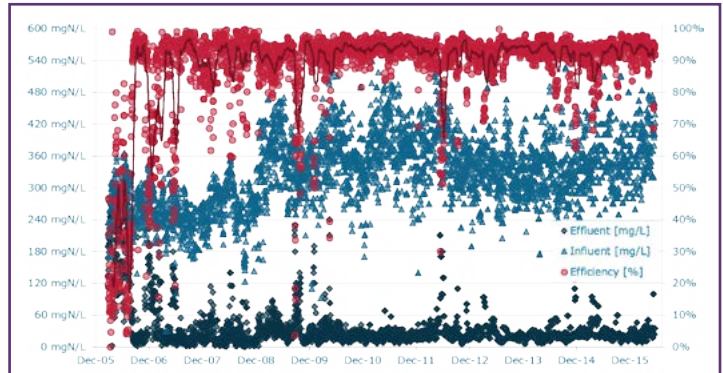
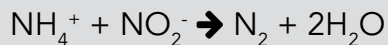

The Olburgen WWTP in Netherlands, with the Ovivo AnammoPAQ® process has reached stable & continuous 92% ammonium and 85% total nitrogen removal average for over 10 years

## HOW IT WORKS

- 1 Ammonia-rich influent
- 2 Aerators for mixing and ammonia removal process
- 3 AnammoPAQ™ separator for biomass retention
- 4 Effluent exits the reactor

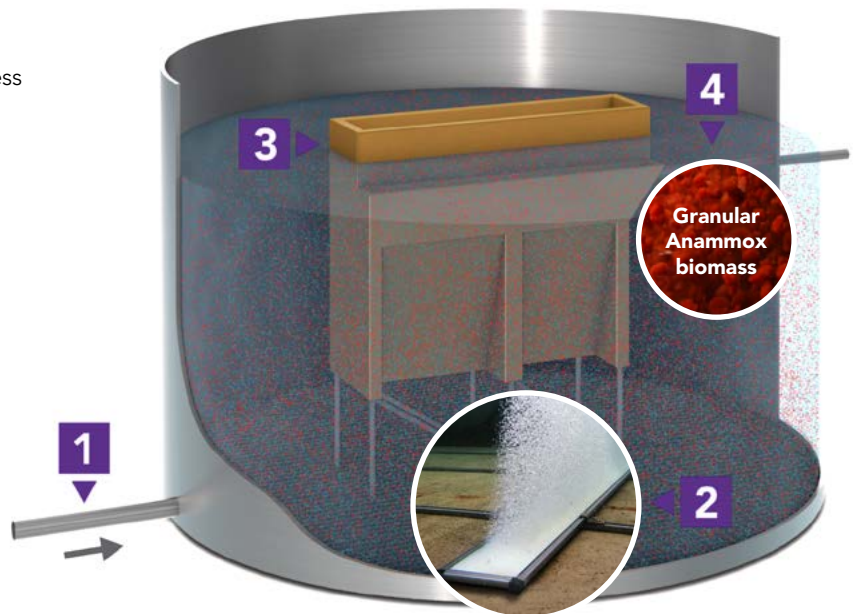

## CONTACT

1-855-GO-OVIVO ☎  
info@ovivowater.com ✉  
www.ovivowater.com 🌐



Proposal  
West Point Treatment  
Plant, WA

ANITA™ Mox

Proj. No. 5700147906

Submitted to: Gus Friedman  
Brown and Caldwell

Submitted by: Robby Bailey  
Application Engineer

Date: 9/3/2019

*This document is confidential and may contain proprietary information.  
It is not to be disclosed to a third party without the written consent of Veolia Water Technologies.*

**Veolia Water Technologies Inc. (dba Kruger)**  
4001 Weston Parkway  
Cary, NC 27513  
tel. +1 919-677-8310 • fax +1 919-677-0082  
[www.krugersusa.com](http://www.krugersusa.com)

***Water Technologies***

## Introduction

Kruger (a subsidiary of Veolia Water Technologies) is pleased to present this budgetary proposal for our ANITA™ Mox process for deammonification of the anaerobic digester rejection water at the King County West Point Treatment Plant. This design is based upon the information we have received from you. The influent design criteria are summarized in Table 1.

In order to achieve the expected removals as summarized in Table 2, we recommend constructing two (2) ANITA Mox process trains. The tank dimensions along with other important process parameters are summarized in Table 3.

It is important that each reactor have the capability for independent control of influent feed and aeration. This can be accomplished through dedicated pumps and blowers or by using high performance modulating valves. We have included one (1) modulating airflow control valve per train as part of Kruger's scope to meet this need. Solids separation is not necessary if ave TSS is < 1,500 mg/L and peaks < 20,000 mg/L. Depending on the facilities dewatering schedule some equalization volume may provide benefits to the operations of the process.

We appreciate the opportunity to provide this proposal to you. If you have any questions or need further information, please contact our local Representative, Bill Reilly of Wm. H. Reilly, or our Regional Sales Manager, Brad Mrdjenovich, at (919)-653-4531 ([brad.mrdjenovich@veolia.com](mailto:brad.mrdjenovich@veolia.com)).

cc: LL, BM, GAT, JYO, project file (Kruger)  
Wm. H. Reilly

Revision	Date	Process Eng.	Comments
0	8/29/2019	JLY, GAT	Initial, budgetary proposal.



---

## We Know Water

Kruger is a water and wastewater solutions provider specializing in advanced and differentiating technologies. Kruger provides complete processes and systems ranging from biological nutrient removal to mobile surface water treatment. The ACTIFLO® Microsand Ballasted Clarifier, BioCon® Dryer, BIOSTYR® Biological Aerated Filter (BAF) and NEOSEP™ MBR are just a few of the innovative technologies offered. Kruger is a subsidiary of Veolia Water, a world leader in engineering and technological solutions in water treatment for industrial companies and municipal authorities.

**Veolia Water Technologies**, the fully-owned subsidiary of **Veolia**, is the world leader in water and wastewater treatment with over 155 years of experience. As an experienced design-build company and a specialized provider of technological solutions in water treatment, Veolia combines proven expertise with unsurpassed innovation to offer technological excellence to our industrial customers. Based on this expertise, we believe that we have developed the best solution for your application. Below is a brief description of the proposed project.

## Energy Focus

Kruger, along with Veolia Water Technologies is dedicated to delivering sustainable and innovative technologies and solutions.

We offer our customers integrated solutions which include resource-efficient technology to improve operations, reduce costs, achieve sustainability goals, decrease dependency on limited resources, and comply with current and anticipated regulations.

Veolia's investments in R&D outpace that of our competition. Our focus is on delivering

- neutral or positive energy solutions
- migration towards green chemicals or zero chemical consumption
- water-footprint-efficient technologies with high recovery rates

Our carbon footprint reduction program drives innovation, accelerates adoption and development of clean technologies, and offers our customers sustainable solutions.

Kruger is benchmarking its technologies and solutions by working with our customers and performing total carbon cost analysis over the lifetime of the installation.

By committing to the innovative development of clean and sustainable technologies and solutions worldwide, Kruger will continue to maximize the financial benefits for every customer.





## We Know Smart Water Management

Veolia is the only company in the world that can combine decades of water treatment expertise, process knowledge and our wide range of domestic and global references into a comprehensive digital solutions platform that provides numerous opportunities to enhance the management of water.



When AQUAVISTA™ is paired with process and equipment instrumentation, your facility will have access to the most advanced suite of cloud-based monitoring, control and technical support mechanisms in the industry. AQUAVISTA™ provides the opportunity to improve your plant's overall performance with enhancements in operational efficiencies and critical asset management. AQUAVISTA™ runs on today's most secure cloud based services and is fully accessible with any common smart devices (phone, pad, tablet).

Four (4) tiers of service are available:

- Portal: A remote monitoring and reporting tool with overview of all plant data and access to important facility documentation.
- Insight: Portal + Data driven performance optimization advice regarding the general status and operational conditions of your plant.
- Assist: Added level of access to Veolia's process experts for process, maintenance, and training support.
- Plant: Operator adjustable levels of automatic control of your treatment facility.

All levels of service provide a simple link to Veolia's customer service group to facilitate easy access to spare parts and other service needs.



## Process Description

### AnoxKaldnes MBBR

The MBBR process is a continuous-flow, non-clogging biofilm reactor containing moving “carrier elements” or media. The media flows with the water currents in the reactor and does not require backwashing or cleaning.

The biomass that treats the wastewater is attached to the surfaces of the media. The media is designed to provide a large protected surface area for the biofilm and optimal conditions for biological activity when suspended in water. AnoxKaldnes media is made from polyethylene and has a density slightly less than water.

The ANITA™ Mox process is a single-stage nitrogen removal process based on the MBBR platform. The process is specifically designed for treatment of waste streams with high ammonia concentrations. The system can achieve ammonia removals of up to 80-90% and total nitrogen removals of up to 75-85%. The treatment method uses only 40% of the oxygen demand of conventional nitrification, and it requires no external carbon source.

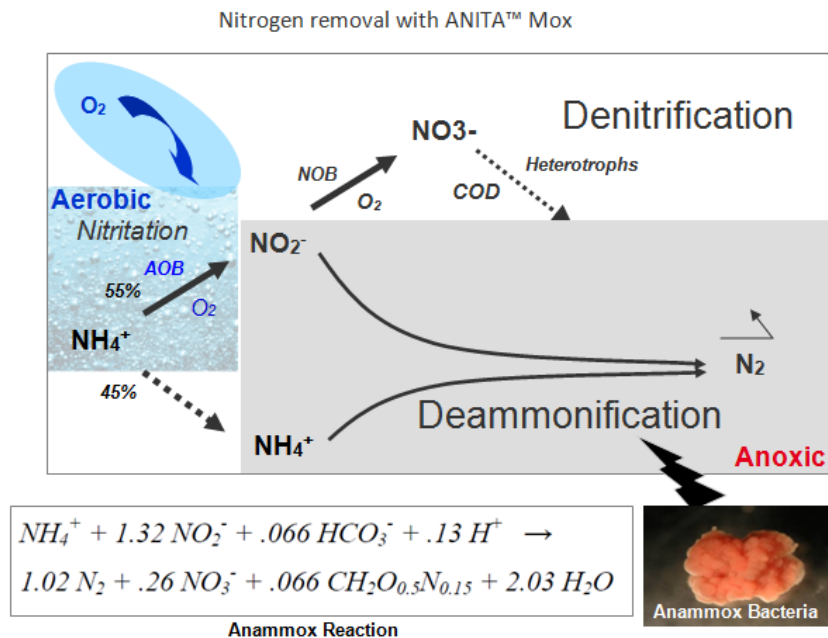

The ANITA Mox process consists of an aerobic nitritation reaction and an anoxic ammonia oxidation (anammox) reaction. The two steps take place simultaneously in different layers of the biofilm. Nitritation occurs in the outer layer of the biofilm. Approximately 55% of the influent ammonia is oxidized to nitrite (NO<sub>2</sub><sup>-</sup>). Anammox activity occurs in the inner layer. In this step, the nitrite produced and the remaining ammonia are utilized by the anammox bacteria and converted to nitrogen gas (N<sub>2</sub>) and a small amount of nitrate (NO<sub>3</sub><sup>-</sup>).



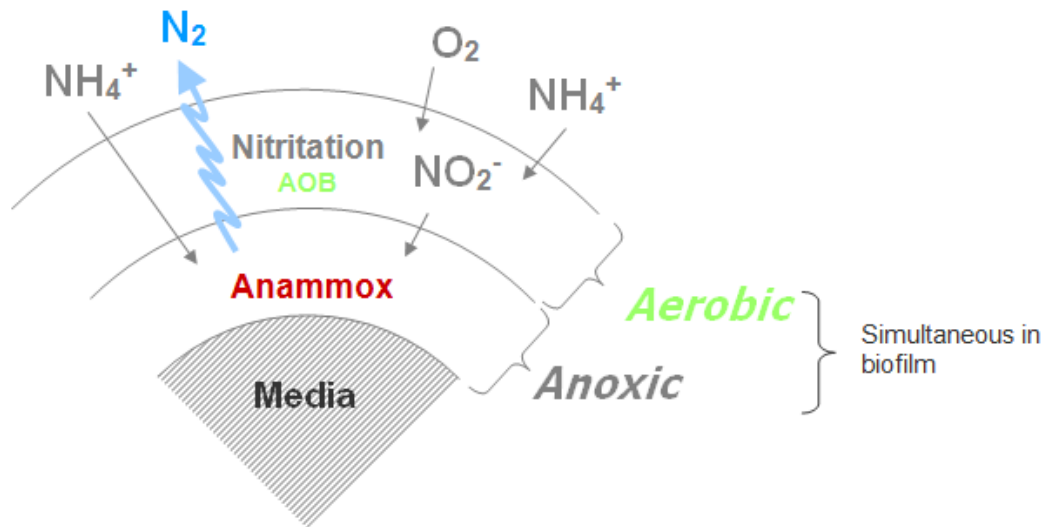

The aerobic and anoxic reactions occur in a single MBBR reactor. The combined biomass grows attached to the AnoxKaldnes media and is retained in the reactor by media screens. This biomass retention is an important characteristic of the system, since the anammox bacteria growth rate is very slow when compared to conventional wastewater bacteria growth rates.



## AnoxKaldnes ANITA™ Mox System Configuration

Kruger proposes the ANITA™ Mox process for deammonification at the King County West Point facility. We recommend constructing two (2) ANITA Mox MBBR process trains using our AnoxK™5 media.

Kruger's equipment scope of supply includes:

- ✓ AnoxKaldnes media
- ✓ Screen assemblies (to keep media in each reactor)
- ✓ Medium bubble aeration grids
- ✓ Mixer
- ✓ Process control system
- ✓ Field instruments

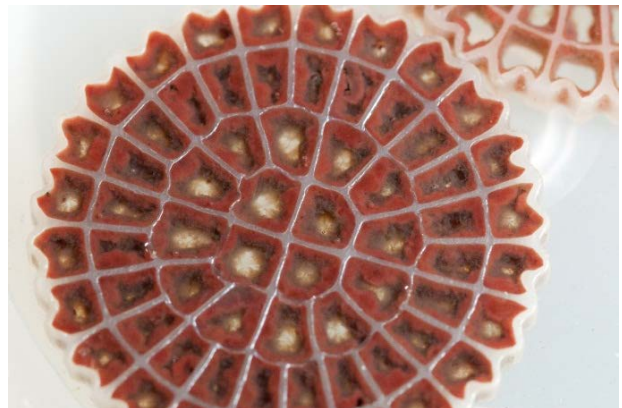



## Design Summary

This design assumes that the side stream entering into the proposed ANITA Mox system contains no toxic compounds and has sufficient alkalinity and that none of the equipment provided would be used in a classified area (e.g. Class 1, Division 1 or Class 1, Division 2).

The ANITA Mox influent design basis is summarized in Table 1. The target effluent criteria for the ANITA Mox system are listed in Table 2. The process design is summarized in Table 3.

Our design approach is to compare two possible treatment scenarios to determine the necessary media volumes and airflow requirements for a two train, newly-constructed reactor with a 21' side water depth. Given these constraints, we have estimated the ammonia removal capacity of the reactor using our proprietary design tools. According to this method, the system achieves > 80% NH<sub>4</sub>-N removal.

**Table 1: Influent Design Basis**

Parameter	Units	Alt. 3A Values
Flow, Design	MGD	0.75
BOD <sub>5</sub> , Design Flow	mg/L	72
COD, Design Flow	mg/L	400
TSS*, Design Flow	mg/L	500
TKN, Design Flow	mg/L	940
NH <sub>4</sub> -N, Design Flow	mg/L	883
Alkalinity, Design Flow*	mg/L	4,677
Elevation	ft	100
Min/Max Temperature	°C	30.0/35.0

\*TSS concentrations to ANITA Mox < 1,500 mg/L ave. and 20,000 mg/L peak do not require centrate sedimentation.

**Table 2: Target Effluent Concentrations**

Parameter	Units	Value
NH <sub>4</sub> -N	mg/L	< 150
Total Inorganic Nitrogen	mg/L	< 230



**Table 3: Process Design Summary**

Parameter	Units	Alt. 3A Values
Number of Process Trains	-	2
Reactor Dimensions (Each)*	ft	42 L × 42 W × 21 SWD
Reactor Volume (Each)	ft <sup>3</sup>	37,044
Reactor Volume (Total)	ft <sup>3</sup>	74,088
Recommended Freeboard for all reactors	ft	2 – 3
Media Type:	-	AnoxK™5
Fill of Biofilm Carriers, All Reactors	%	55
Media Volume (Each reactor)	ft <sup>3</sup>	20,374
Media Volume (Total)	ft <sup>3</sup>	40,748
Aeration System Type	-	Medium Bubble
Residual DO, Design	mg/L	1.5
Estimated Process Air Requirement, Design	SCFM	~3,160
Pressure (From Top of Drop Pipe)	psi	9.0

\* Reactor geometries can be modified as necessary to accommodate site conditions



---

## Scope of Supply

Kruger is pleased to present our scope of supply which includes process engineering design, equipment procurement, and field services required for the proposed treatment system, as related to the equipment specified. The work will be performed to Kruger's high standards under the direction of a Project Manager. All matters related to the design, installation, or performance of the system shall be communicated through the Kruger representative giving the Engineer and Owner ready access to Kruger's extensive capabilities.

### **Process and Design Engineering**

Kruger will provide process engineering and design support for the system as follows:

- Process Engineering consisting of aeration system sizing and configuration, sieve and outlet design.
- Review and approval of P&I Diagram for the AnoxKaldnes ANITA Mox portion of the process. Preliminary General Arrangement Drawings and review and approval of final General Arrangement Drawings for the process. Review of reactor drawings with respect to penetrations and dimensions, excluding structural design.
- Equipment installation instructions for all equipment supplied by Kruger.

### **Field Services**

Kruger will furnish a Service Engineer to perform the following tasks:

- Inspect installation of key pieces of equipment during construction.
- Inspect the completed system prior to startup.
- Assist the Contractor with initial startup of the system.
- Train the Owner's staff in the proper operation and maintenance of the AnoxKaldnes ANITA Mox system.
- Test and start any Kruger-supplied control equipment, including PLC programming and SCADA systems.



**AnoxKaldnes ANITA™ Mox System Equipment (Alt. 3A)**

<b>Mechanical Equipment Items</b>	<b>Qty</b>	<b>Description</b>
AnoxKaldnes AnoxK™5 Media, (ft <sup>3</sup> )	40,748	Carrier elements are made of high density polyethylene. The total media quantity will include a volume of ~5% seeded media.
Cylindrical Screen Assemblies	4	Two (2) per reactor. 304L SS. 23"ø perforated plate pipes terminated in ANSI flanges for mounting directly to the tank wall.
Medium Bubble Aeration System	8	Four (4) air grids per reactor. 304L SS including header, lateral piping, and hardware (excluding concrete anchor bolts). One (1) manual BFV for each air grid drop pipe is also provided.
Specially Designed Mechanical Mixers	2	One (1) per ANITA Mox Reactor. Includes VFD.
Airlift Pump	6	Three (3) airlift pumps per ANITA Mox reactor for foam suppression.
Modulating Airflow Control Valves	2	One (1) actuated High-Performance Butterfly Valve for each aerobic reactor.

<b>Instrumentation and Controls Equipment Items</b>	<b>Qty</b>	<b>Description</b>
PLC Control Panel	1	NEMA 12 Freestanding or Wall Mount Control Panel (For Indoor Use). ControlLogix PLC; Panelview HMI; 120V Feed
pH-based Control Logic	1	For optional mode of aeration control.
High Level Float Switch	2	One (1) for each media zone.
DO Probe (LDO)	2	One (1) for each Aerobic zone. Aerobic Zone DO Monitoring
pH meter	2	One (1) pH meter for each ANITA Mox reactor.
Influent Ammonia Nitrogen Probe	1	One (1) ammonia nitrogen probe for all process trains
Combination Ammonia / Nitrate Nitrogen Probes	2	One (1) combination ammonia / nitrate nitrogen probe for each ANITA Mox reactor.
Thermal Mass Flowmeter	2	One (1) for each ANITA Mox reactor for air flow control
Magnetic Flowmeter	2	One (1) magnetic flow meter per reactor to measure influent flow.
<b>Instrumentation and Controls (NOT INCLUDED)*</b>	<b>Qty</b>	<b>Description</b>
Centrate Feed Pump	2+1	One (1) duty plus one (1) standby to feed centrate from equalization tank. Includes VFD.



## Notes Regarding System Design and Installation

- A note on concrete specifications: For any MBBR or IFAS system, regardless of manufacturer, it is sound practice to require good, quality concrete work for the process reactors. The Consulting Engineer's standard concrete specification section is typically adequate to eliminate large holes, excessive form marks, large pockets, and excessively rough areas. It is particularly important to eliminate the potential for annular space around media retention screens.
- A note on construction sequencing: It is important, particularly for IFAS installations, to have level detection and level communication systems in place and operational prior to the filling of process tanks with water and media.

## Scope of Supply BY INSTALLER/PURCHASER

The scope of supply by others for the AnoxKaldnes ANITA™ Mox system should include, but is not limited to, the following items:

- All civil/site and electrical work.
- A concrete foundation for the tanks.
- Reactors to house the MBBR treatment equipment.
- All provisions for interconnecting piping.
- Unloading, storage and installation of equipment.
- Install and test all level floats, level transmitters, level alarms, and alarm communication devices prior to filling a process tank with media and water
- Centrate equalization tanks
- Cover for reactor tanks (if necessary)
- Temporary provisions for screened primary or secondary effluent during startup.
- Temporary reactor heating during startup.
- Mixer bridges and other structural modifications for the reactors.
- Video recording of any training activities.

## Design Options

In addition to the proposed system as detailed herein, Kruger is able to further incorporate our process and controls expertise into wastewater treatment plants, allowing municipalities to meet stringent effluent requirements and future plant upgrades. Kruger is also able to offer our instrumentation and controls expertise to build upon the proposed system by providing a **customized plant-wide SCADA system** or designing a **Motor Control Center (MCC)**, providing clients a single source responsibility for plant controls. Please contact Kruger if the options above are of interest or to be included in the current proposed system or future upgrades. *\*\*Please note that the design options listed above are not included in the pricing noted herein.*



---

## Schedule

- Shop drawings will be submitted within 6-8 weeks of receipt of an executed contract by all parties.
- All equipment will be delivered within 18-20 weeks after receipt of written approval of the shop drawings.
- Installation manuals will be furnished upon delivery of equipment.
- Operation and Maintenance Manuals will be submitted within 90 days after receipt of approved shop drawings.

## Pricing

The price for the AnoxKaldnes ANITA™ Mox system, as defined herein, including process and design engineering, field services, and equipment supply is:

**Alternate 3A: \$2,200,000**

Pricing is FOB shipping point, with freight allowed to the job site. This pricing does not include any sales or use taxes. In addition, pricing is valid for ninety (90) days from the date of issue.

***Please note that the above pricing is expressly contingent upon the items in this proposal and are subject to Kruger's Standard Terms of Sale detailed herein.***

### **Kruger Standard Terms of Payment**

The terms of payment are as follows:

- 10% on receipt of fully executed contract
- 15% on submittal of shop drawings
- 75% on the delivery of equipment to the site

Payment shall not be contingent upon receipt of funds by the Contractor from the Owner. There shall be no retention in payments due to Kruger. All other terms per our Standard Terms of Sale are attached.

All payment terms are net 30 days from the date of invoice. Final payment not to exceed 120 days from delivery of equipment.



## ANITA Mox ALTERNATIVES SUMMARY TABLE

Parameter	Alt 1	Alt 2B/2C	Alt 3A	Alt 4B/4D		
Flow, mgd	0.6	0.65	0.75	0.3		
TSS, mg/L*	< 500	< 500	< 500	< 500		
TKN, Peak month, (lb/d)	5,070	5,400	6,140	2,530		
Alkalinity, mg/L as CaCO3	4,677	4,677	4,677	4,677		
Temp, °C	30	30	30	30		
New Construction / Retrofit	New Construction	New Construction	New Construction	New Construction	Retrofit A	Retrofit B
Number of Trains	2	2	2	2	3	4
Dimensions (each Train) (L'xW'xSWD)**	42x42x21	42x42x21	42x42x21	42x42x21	34x34x9	34x34x9
Volume Each Train (ft3)	37,044	37,044	37,044	18,522	10,404	10,404
Total System Volume (ft3)	74,088	74,088	74,088	37,044	31,212	41,616
Total Media Volume (ft3)	33,340	35,510	40,376	16,637	16,637	16,637
Media Fill Fraction	45%	48%	55%	45%	53%	40%
Airflow @ 21' New Construction (SCFM)	2,600	2,770	3,150	1,300	--	--
Airflow @ 9' Retrofit (SCFM)	--	--	--	--	3,350	3,350
Budgetary Price Estimate	\$2,000,000		\$2,200,000	\$1,500,000		

\*TSS concentrations to ANITA Mox < 1,500 mg/L ave. and 20,000 mg/L peak do not require centrate sedimentation.

\*\* Reactor geometries can be modified as necessary to accommodate site conditions





# Kruger Standard Terms of Sale

1. Applicable Terms. These terms govern the purchase and sale of the equipment and related services, if any (collectively, "Equipment"), referred to in Seller's purchase order, quotation, proposal or acknowledgment, as the case may be ("Seller's Documentation"). Whether these terms are included in an offer or an acceptance by Seller, such offer or acceptance is conditioned on Buyer's assent to these terms. Seller rejects all additional or different terms in any of Buyer's forms or documents.
  2. Payment. Buyer shall pay Seller the full purchase price as set forth in Seller's Documentation. Unless Seller's Documentation provides otherwise, freight, storage, insurance and all taxes, duties or other governmental charges relating to the Equipment shall be paid by Buyer. If Seller is required to pay any such charges, Buyer shall immediately reimburse Seller. All payments are due within 30 days after receipt of invoice. Buyer shall be charged the lower of 1 ½% interest per month or the maximum legal rate on all amounts not received by the due date and shall pay all of Seller's reasonable costs (including attorneys' fees) of collecting amounts due but unpaid. All orders are subject to credit approval.
  3. Delivery. Delivery of the Equipment shall be in material compliance with the schedule in Seller's Documentation. Unless Seller's Documentation provides otherwise, Delivery terms are F.O.B. Seller's facility.
  4. Ownership of Materials. All devices, designs (including drawings, plans and specifications), estimates, prices, notes, electronic data and other documents or information disclosed by Seller or prepared solely by Seller or Buyer or jointly by Seller and Buyer in connection with this Agreement, and all intellectual property rights therein, shall be and remain the confidential and proprietary property of Seller, whether or not patented by Seller ("Work Product"). Buyer hereby irrevocably assigns all rights in any Work Product to Seller. Seller grants Buyer a non-exclusive, non-transferable (except to a successor-in interest to the ownership of the Equipment), paid-up license to use the Work Product solely in connection with Buyer's use, operation, repair and maintenance of the Equipment at the Jobsite defined in this Agreement. Buyer may not disclose, share, transfer, or sell any such Work Product to third parties without Seller's prior written consent and such consent may be arbitrarily withheld. Buyer agrees not to resell, transfer or give any of the biologically colonized media or bacteria from the system to any party other than Seller or any of Seller's affiliates without the prior written consent of Seller for a period of fifteen (15) years from the effective date of this Agreement. Buyer shall not cultivate bacteria or use biomass carriers retrieved from the ANITA Mox system for any research or non-research purposes without prior written consent of the Seller. Any new developments, discoveries or inventions resulting from the operation of the ANITA Mox system in which the ANITA Mox process is a component or is in any way incorporated in whole or in part shall be owned solely by the Seller.
  5. Changes. Seller shall not implement any changes in the scope of work described in Seller's Documentation unless Buyer and Seller agree in writing to the details of the change and any resulting price, schedule or other contractual modifications. This includes any changes necessitated by a change in applicable law occurring after the effective date of any contract including these terms.
  6. Warranty. Subject to the following sentence, Seller warrants to Buyer that the Equipment shall materially conform to the description in Seller's Documentation and shall be free from defects in material and workmanship. The foregoing warranty shall not apply to any Equipment that is specified or otherwise demanded by Buyer and is not manufactured or selected by Seller, as to which (i) Seller hereby assigns to Buyer, to the extent assignable, any warranties made to Seller and (ii) Seller shall have no other liability to Buyer under warranty, tort or any other legal theory. If Buyer gives Seller prompt written notice of breach of this warranty within 18 months from delivery or 1 year from beneficial use, whichever occurs first (the "Warranty Period"), Seller shall, at its sole option and as Buyer's sole remedy, repair or replace the subject parts or refund the purchase price therefore. If Seller determines that any claimed breach is not, in fact, covered by this warranty, Buyer shall pay Seller its then customary charges for any repair or replacement made by Seller. Seller's warranty is conditioned on Buyer's (a) operating and maintaining the Equipment in accordance with Seller's instructions, (b) not making any unauthorized repairs or alterations, and (c) not being in default of any payment obligation to Seller. Seller's warranty does not cover damage caused by chemical action or abrasive material, misuse or improper installation (unless installed by Seller). THE WARRANTIES SET FORTH IN THIS SECTION ARE SELLER'S SOLE AND EXCLUSIVE WARRANTIES AND ARE SUBJECT TO SECTION 10 BELOW. SELLER MAKES NO OTHER WARRANTIES OF ANY KIND, EXPRESS OR IMPLIED, INCLUDING WITHOUT LIMITATION, ANY WARRANTY OF MERCHANTABILITY OR FITNESS FOR PURPOSE.
  7. Indemnity. Seller shall indemnify, defend and hold Buyer harmless from any claim, cause of action or liability incurred by Buyer as a result of third party claims for personal injury, death or damage to tangible property, to the extent caused by Seller's negligence. Seller shall have the sole authority to direct the defense of and settle any indemnified claim. Seller's indemnification is conditioned on Buyer (a) promptly, within the Warranty Period, notifying Seller of any claim, and (b) providing reasonable cooperation in the defense of any claim.
  8. Force Majeure. Neither Seller nor Buyer shall have any liability for any breach (except for breach of payment obligations) caused by extreme weather or other act of God, strike or other labor shortage or disturbance, fire, accident, war or civil disturbance, delay of carriers, failure of normal sources of supply, act of government or any other cause beyond such party's reasonable control.
  9. Cancellation. If Buyer cancels or suspends its order for any reason other than Seller's breach, Buyer shall promptly pay Seller for work performed prior to cancellation or suspension and any other direct costs incurred by Seller as a result of such cancellation or suspension.
  10. LIMITATION OF LIABILITY. NOTWITHSTANDING ANYTHING ELSE TO THE CONTRARY, SELLER SHALL NOT BE LIABLE FOR ANY CONSEQUENTIAL, INCIDENTAL, SPECIAL, PUNITIVE OR OTHER INDIRECT DAMAGES, AND SELLER'S TOTAL LIABILITY ARISING AT ANY TIME FROM THE SALE OR USE OF THE EQUIPMENT SHALL NOT EXCEED THE PURCHASE PRICE PAID FOR THE EQUIPMENT. THESE LIMITATIONS APPLY WHETHER THE LIABILITY IS BASED ON CONTRACT, TORT, STRICT LIABILITY OR ANY OTHER THEORY.
- Miscellaneous. If these terms are issued in connection with a government contract, they shall be deemed to include those federal acquisition regulations that are required by law to be included. These terms, together with any quotation, purchase order or acknowledgement issued or signed by the Seller, comprise the complete and exclusive statement of the agreement between the parties (the "Agreement") and supersede any terms contained in Buyer's documents, unless separately signed by Seller. No part of the Agreement may be changed or cancelled except by a written document signed by Seller and Buyer. No course of dealing or performance, usage of trade or failure to enforce any term shall be used to modify the Agreement. If any of these terms is unenforceable, such term shall be limited only to the extent necessary to make it enforceable, and all other terms shall remain in full force and effect. Buyer may not assign or permit any other transfer of the Agreement without Seller's prior written consent. The Agreement shall be governed by the laws of the State of North Carolina without regard to its conflict of laws provisions.



DATE: 1 September, 2019  
 TO: **Matt Winkler, Gus Friedman, Stantec**  
 FROM: Daniel Thompson - World Water Works (WWW)  
 CC: Chandler Johnson Praveen Yanamandra – WWW  
 Chris McCalib – Treatment Equipment Company (TEC)  
 RE: Information on DEMON® Process – West Point WWTP – Rev0

Per your request for design and sizing for a DEMON® treatment system based on the **design criteria provided**, please find below our design summary based on the information provided. Below are some graphs showing the typical cycle of a DEMON® treatment system.

## 1. DEMON® TREATMENT PROCESS

Deammonification represents a short-cut in the N-metabolism pathway and comprises of 2 steps. About half the amount of ammonia is oxidized to nitrite and then residual ammonia and nitrite is anaerobically transformed to elementary nitrogen. See this shortcut in the diagram below. By using this process there is no excess oxygen required or external carbon source to achieve nitrogen removal.

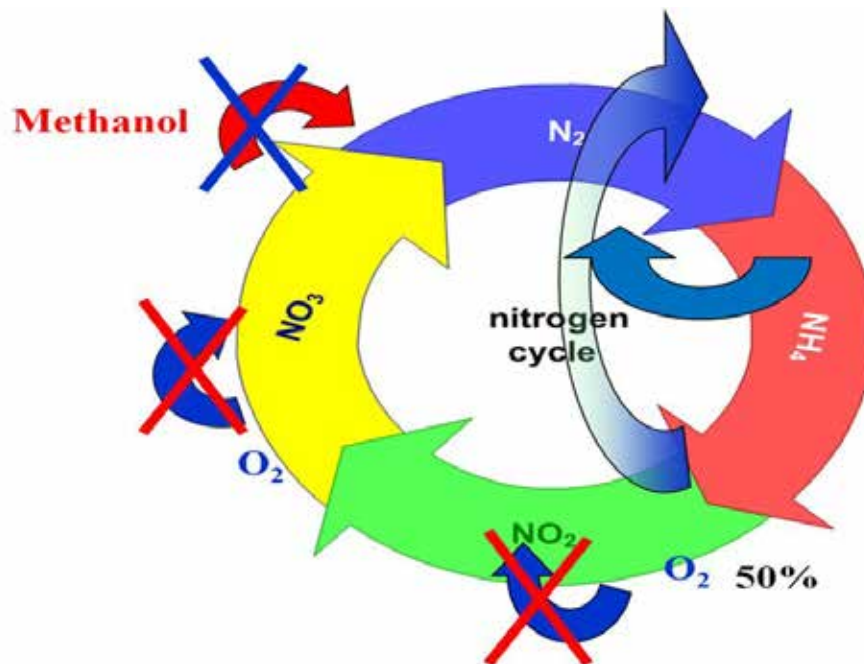

Figure 1 – NITROGEN CYCLE WITH SHORT CUT NITROGEN REMOVAL ADDED

Implementation of the University of Innsbruck pH controlled strategy for the Continuous DEMON<sup>®</sup> process for deammonification of reject water in a single sludge system is what this design is proposed around. The **specific energy demand of the side stream process results in 1.4 kWh per kg ammonia nitrogen removed comparing to about 6.5 kWh of mainstream treatment.** This process is achieving results of greater than 90% at the Strass WWTP (see data presented below). Biomass enrichment and Continuous Demon<sup>®</sup> -start up is key for this process to achieve its results in a short period of time and this proposal provides the seed sludge and start up assistance to ensure achieving the goal of efficient nitrogen removal.

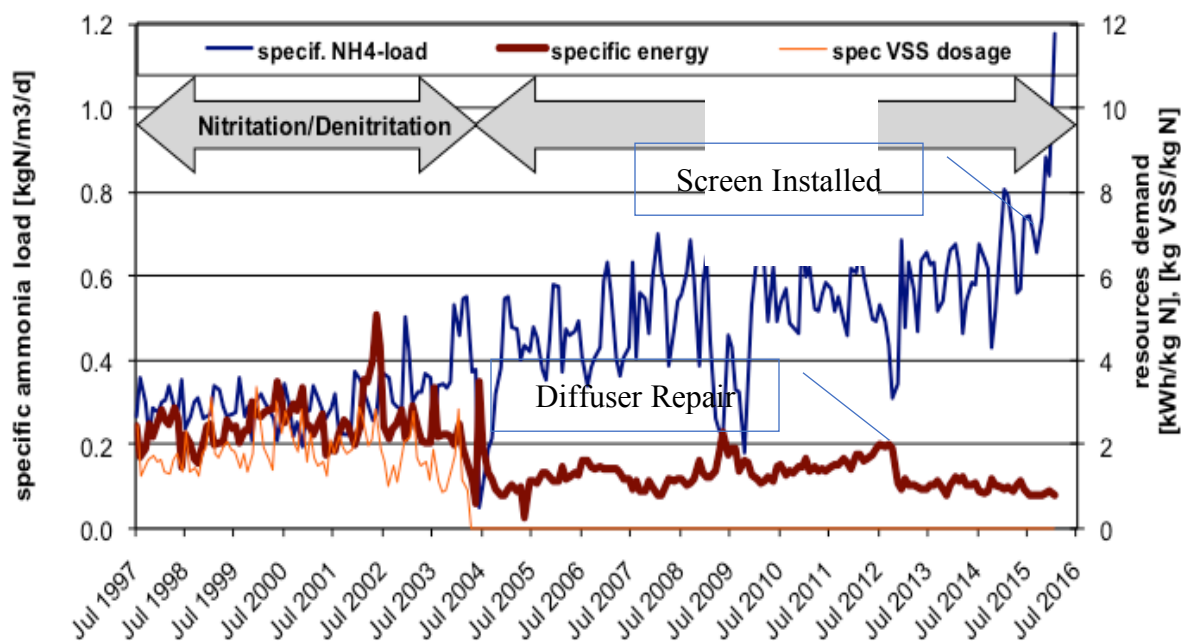

FIGURE 2 – STRASS NITROGEN PROFILE (1997 – 2016) WITH LOADING RATE AND SPECIFIC ENERGY

**Design Concept**

Based on the design criteria provided, we have 3 designs as Alt 1 and Alt 2B&2C were very close in loading. The below table summarizes the design conditions. The overall design concept for is to use two (2) new reactors for Alt 1, Alt 2B & 2C and Alt 3A and one (1) new reactor for Alt 4B&D to create a DEMON® treatment system and a new EQ / storage tank for the design conditions provided.

Parameter	Alt 1	Alt 2B/2C	Alt 3A	Alt 4B/4D
TSS, mg/L	< 500	< 500	< 500	< 500
TKN, mg/L	1,485	1,485	1,485	1,485
Alkalinity, mg/L as CaCO <sub>3</sub>	4677	4677	4677	4677
Temp, °C	25-30	25-30	25-30	25-30
Min day Loading	1,250 lb/day	1,200 lb/day	1,250 lb/day	600 lb/day
Average Loading	4,150 lb/day	4,050 lb/day	4,200 lb/day	2,000 lb/day
<b>Peak month Loading</b>	<b>5,070 lb/day</b>	<b>5,400 lb/day</b>	<b>6,140 lb/day</b>	<b>2,530 lb/day</b>
Peak day Loading	7,600 lb/day	8,100 lb/day	9,200 lb/day	3,800 lb/day
Average Flow	0.3349 MGD	0.3268 MGD	0.3389 MGD	0.1614 MGD
<b>Peak month Flow</b>	<b>0.4091 MGD</b>	<b>0.4357 MGD</b>	<b>0.4954 MGD</b>	<b>0.2041 MGD</b>
Peak day Flow	0.6132 MGD	0.6536 MGD	0.7424 MGD	0.3066 MGD

We envision using a concrete tanks for the DEMON® process and below are the number of trains and dimensions suggested along with blower air flow, brake horsepower of the blowers for each option at average month loads and maximum month loads. New mixers and aeration system will be placed in each reactor for providing the mixing energy for suspension of the granules, proper mixing distribution of the influent feed flow and provide the necessary aeration for nitrification. An internal settling zone will be used to settle out the MLSS / Anammox biomass and allow the treated wastewater to be discharged on a continuous basis. A single control panel will be provided to control process.

Parameter	Alt 1	Alt 2B/2C	Alt 3A	Alt 4B/4D
Number of Trains	2	2	2	1
Length (ft)	48	48	60	48
Width (ft)	40	40	40	40
SWD (ft)	21	21	21	21
MM Air Flow (SCFM)	833	938	1010	832
MM Blower bHP	55.3	62.2	67.0	55.3
AM Air Flow (SCFM)	682	703	690	657
AM Blower bHP	45.3	46.8	45.9	43.6
Installed Blower HP	75	100	100	75

We see many advantages in operating the system as a continuous process as it will allow for a lower installed HP for the blowers and feed pumps, not require the Decanter and operate continuously with higher Anammox biomass retention which allows for higher operating loading rates.

We have designed the system based on having removal efficiencies of 80% for ammonia and 70% for TIN however the aeration system is sized based on 85% ammonia removal. We have also assumed minimum operating temperature of 25C.

Based on the influent alkalinity value of 4,677 mg/L, this will just be able to provide for 80% removal of ammonia and should greater removal of ammonia be desired, sodium bicarbonate will be required.

The below table is estimated effluent loads for both ammonia and Total Inorganic Nitrogen for all the alternatives reviewed.

<b>Parameter</b>	<b>Alt 1</b>	<b>Alt 2B/2C</b>	<b>Alt 3A</b>	<b>Alt 4B/4D</b>
AM Effluent NH3-N (lb/day)	830	810	840	400
AM Effluent TIN (lb/day)	1,195	1,166	1,210	576
MM Effluent NH3-N (lb/day)	1,015	1,080	1,230	506
MM Effluent TIN (lb/day)	1,460	1,555	1,770	730

**DEMON® TANK COMPONENTS**

- a) **Biomass Separation System** – A micro-screen will be used for this project and will have submerged pumps feeding it for a period time to waste out the AOB and NOB bacteria. The waste sludge of AOB and NOB bacteria will be discharged from the system while the underflow (Anammox bacteria) will be returned to the reactor.

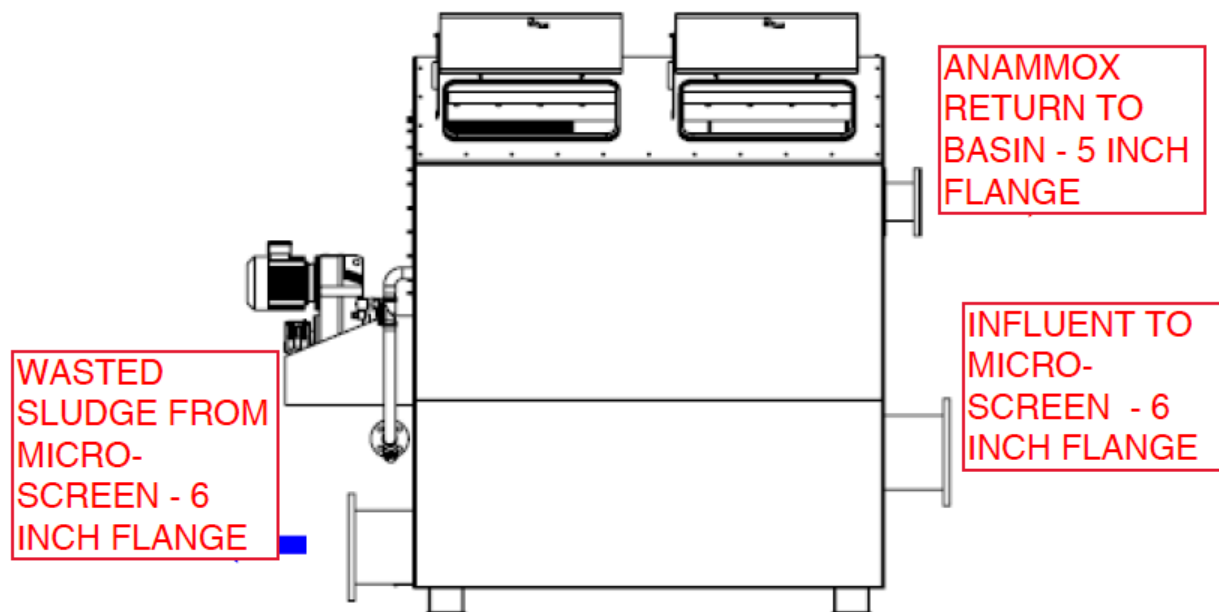

FIGURE 3 – MICRO-SCREEN (INSTALLED), SIDE VIEW



Below are graphs of the loading and % removal of the Anammox treatment system at Strass WWTP in Austria using the microscreen since fall 2015. In February 2016, The specific load was increased to over 1.4 kg/m<sup>3</sup>-day while still maintaining greater than 90% removal of Ammonia-nitrogen.

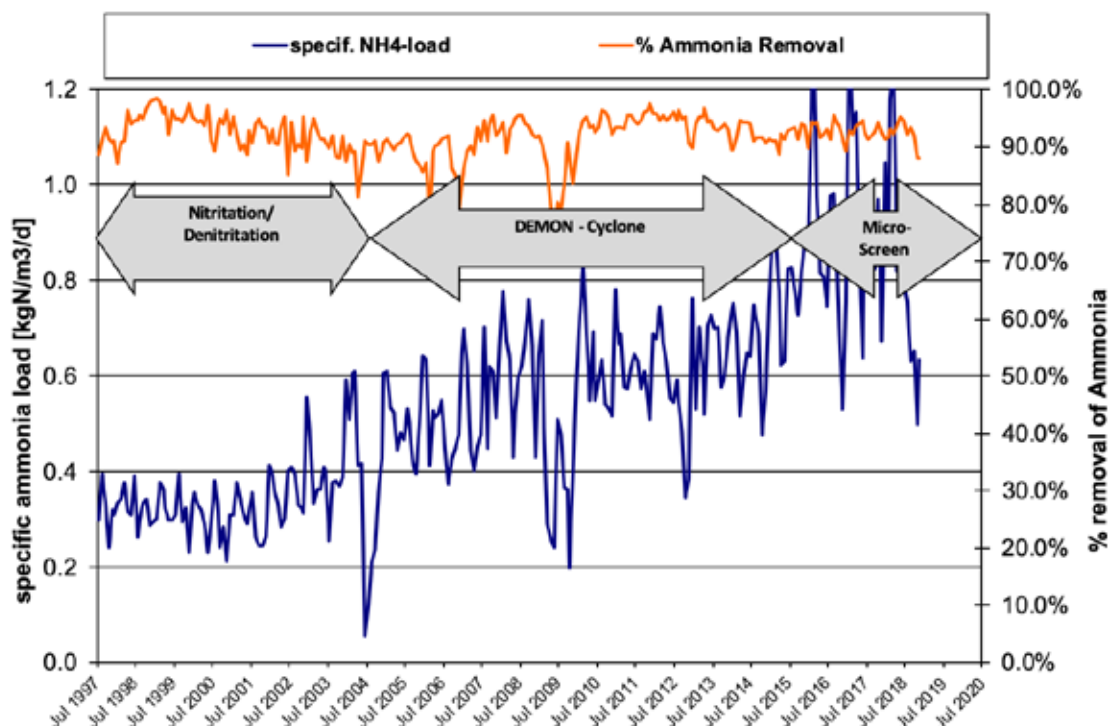

FIGURE 4 – AMMONIA LOAD AND PERCENT REMOVAL VS TIME (1997 – 2018)

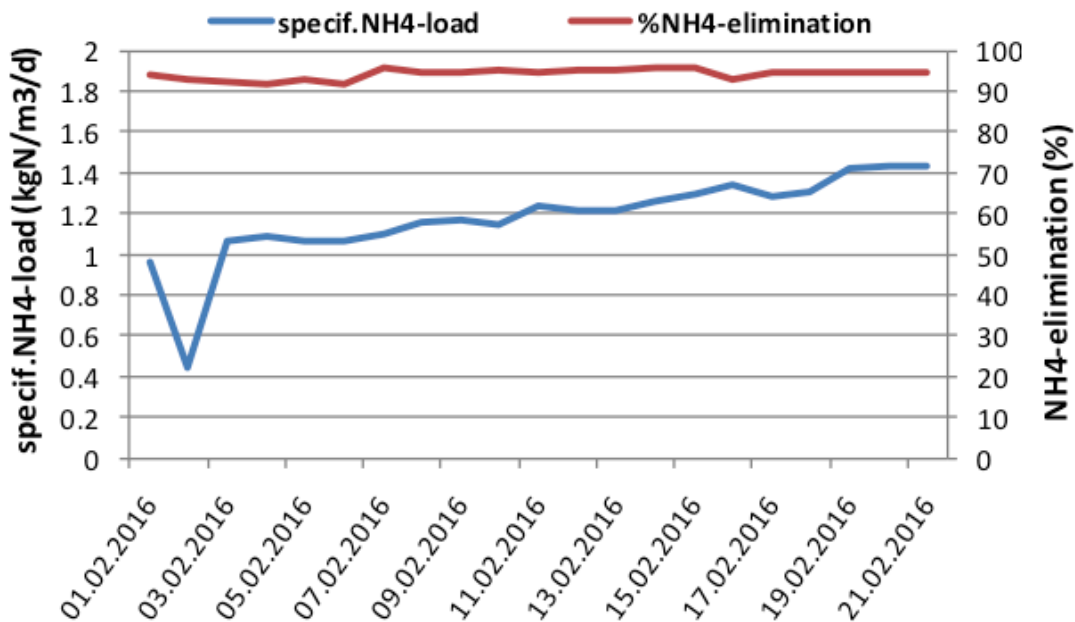

FIGURE 5 – SPECIFIC LOAD AND AMMONIA PERCENT REMOVAL – FEB 2016



- b) **Instrument Float** – the instruments for control of the process will be installed on a float system which will float with the level of the system. One (1) pH probe & one (1) DO probe for control of the overall operation of the process will be provided. A dedicated controller for the DO and pH is our recommendation. The conductivity probe is also to be provided with its own controller. Spare instrument locations will be provided in the instrument float for adding additional analyzers over time.



FIGURE 6 – INSTRUMENT FLOAT EQUIPMENT

- c) **Seed Sludge** – for the quick start up of the Continuous DEMON® treatment process, an adequate amount of seed sludge will be supplied. The seed sludge will be shipped in as dry content possible based on the harvesting technique used and will be added to the systems as they are started up.



FIGURE 7 – SEED SLUDGE SHIPPING CONTAINER

- d) **Aeration System** – The Messner aeration system will be supplied in each tank. The amount of panels is provided in the scope of supply section and is subject to final design.



FIGURE 8 – MESSNER PANEL INSTALLED / AERATION PATTERN TEST

- e) **Side Mounted Mixers** – Landia side mounted mixers will be used to maintain mixing energy within each reactor. The mixers will help re-suspend the “reds” during the start up phase of each cycle. VFD’s will be provided to allow the mixers to be turned down and save on energy during the overall operation of the cycle.

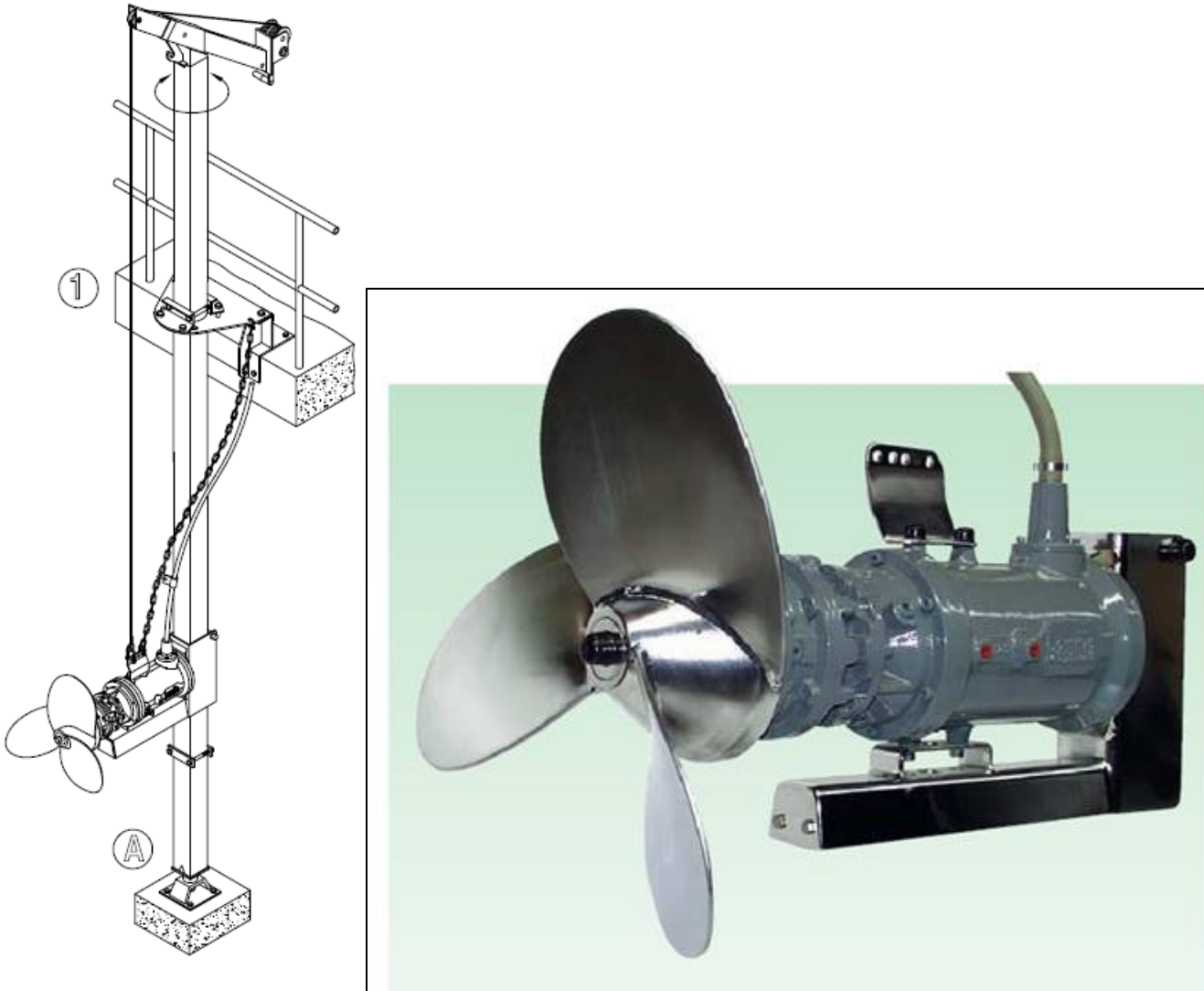
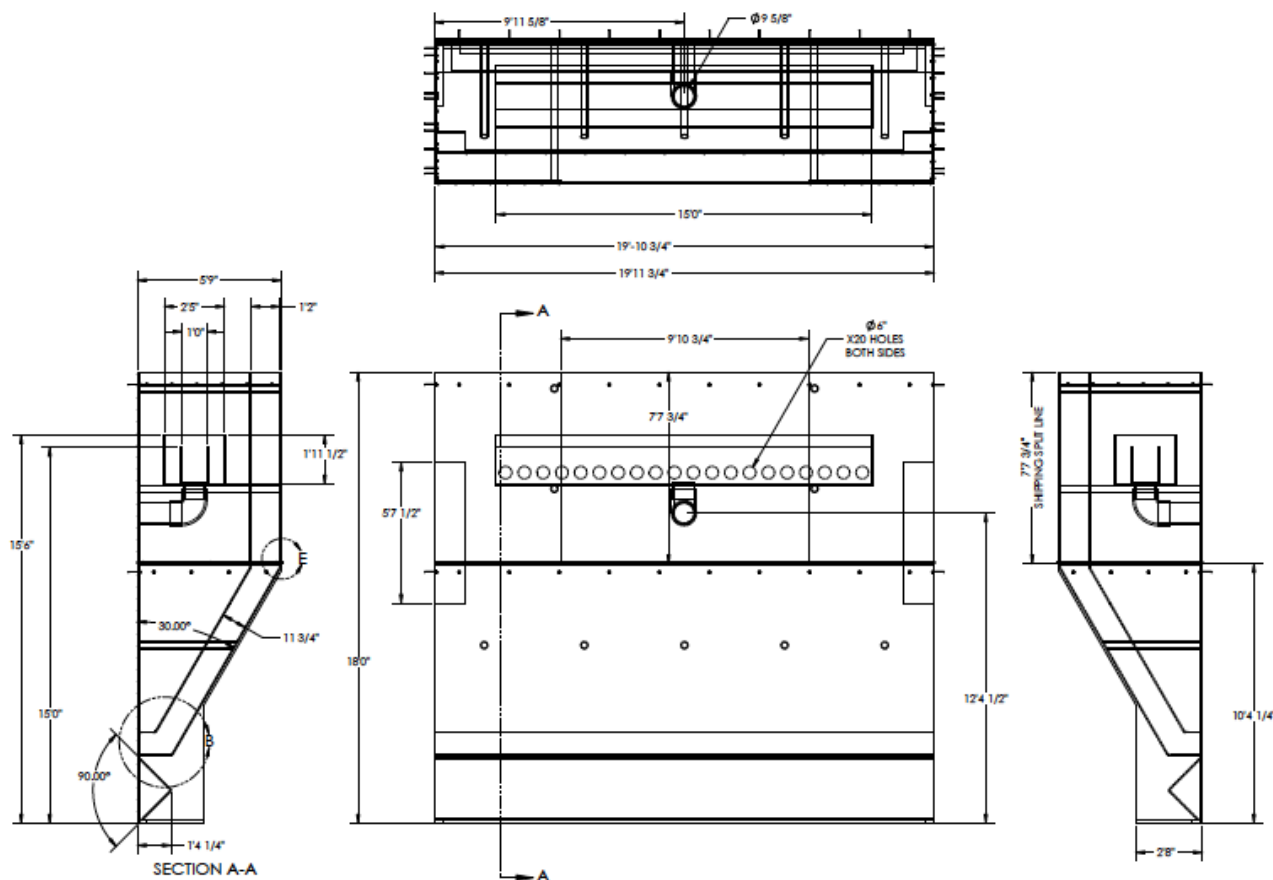

FIGURE 9 – LANDIA MIXER

- f) **Internal Settling Zone** – An internal settling zone will be provided to allow for a continuous operation of the Anammox treatment system. Clarified effluent will be discharged back into the main process while the settled MLSS will be returned to the Anammox reactor. The waste stream enters the vessel and immediately the velocity is reduced to enhance particle separation. The vessel is polypropylene, so the operating pH has no effect on the systems longevity. The “clean” liquid is continuously removed from the top of the settling area and passes through holes into an effluent collection piping system. From the effluent collection piping system, the wastewater gravity feeds out of the system. Heavy solids settle into the bottom where they fall back into the main DEMON® process tank on an automatic basis. The system is compact, robust, cleanable, and does not have moving parts.



**FIGURE 10 - View of the Settling Zone from Top, Front and back sides. To be anchored to outside and back concrete walls.**

g) **Blowers** – Positive displacement blowers capable of providing the necessary turndown for operation of the DEMON<sup>®</sup> system are to be provided.

<u>Design Case – Alt 1, Alt 2B&amp;2C</u>	<u>Model</u>	<u>Air Flow</u>	<u>Est. HP</u>	<u>Est. bHP</u>
1 duty + 1 standby per Process train (4 total provided)	GM 35S	682 SCFM	100 HP	45.3 bHP Alt 1 – AM
		833 SCFM		55.3 bHP Alt 1 – MM
		703 SCFM		46.8 bHP Alt 2 – AM
		938 SCFM		62.2 bHP Alt 2 – MM
<u>Design Case – Alt 3A</u>	<u>Model</u>	<u>Air Flow</u>	<u>Est. HP</u>	<u>Est. bHP</u>
1 duty + 1 standby per Process train (4 total provided)	GM 35S	690 SCFM	100 HP	45.3 bHP Alt 3 – AM
		1,010 SCFM		55.3 bHP Alt 3 – MM
<u>Design Case – Alt 4B/4D</u>	<u>Model</u>	<u>Air Flow</u>	<u>Est. HP</u>	<u>Est. bHP</u>
1 duty + 1 standby per Process train (2 total provided)	GM 35S	657 SCFM	75 HP	43.6 bHP Alt 4 – AM
		832 SCFM		55.3 bHP Alt 4 – MM

This blower design will allow the most flexibility in allowing the system have efficient use of blower capacity during start up and low load periods of time. The blowers will each have its own sound enclosure to maintain < 75 db sound rating. Each blower will also be equipped with a variable frequency drive unit to allow efficient turndown of the blower while maintaining the proper dissolved oxygen concentration in the Continuous DEMON<sup>®</sup> reactor.



FIGURE 11 – AERZEN BLOWER WITH SOUND ENCLOSURE

h) **Documentation / Design / License** – All necessary documentation and design information will be provided as well as a license for treating the Maximum Month Loads.

## 2. CONTROLS

World Water Works provides pre-wired control panels to optimally control all equipment provided within the scope of this proposal. World Water Works includes an Ethernet connection with the control panel to allow remote access to the program and to assist in troubleshooting.

### INSTRUMENTATION

Electrical Enclosure	<b>Hoffman, NEMA 4</b>
PLC	<b>Allen Bradley</b>
Software	<b>Allen Bradley</b>
Touchscreen	<b>15 inch Color Touch Screen</b>

### ADDITIONAL OPTIONS PROVIDED

**Remote Operation Capability**

**UL Listed Panel**



FIGURE 12 – CONTROL PANEL WITH PLC

**PLC Panel** – The PLC panel and control program is the heart of the Continuous DEMON® process and its integral to our scope of supply. The PLC program will have each reactor created as a separate reactor. The reactor will have independent feed of raw centrate, aeration and mixing time. A touch panel with remote access is standard for allowing WWW access to the system and provides operational oversight.



**DESIGN FOR 25C – Alt 1 - MM**

<b>Influent Flow and Wastewater Characteristics</b>	<b>Design</b>		<b>Design</b>	
	Wastewater temperature in DEMON® Anammox-tank	25	°C	77
Daily water flow	1,549	m <sup>3</sup> /d	0.409	MGD
Ammonia (NH <sub>4</sub> -N) Load	2,300	kg/d	5,070	lb/day
Ammonia (NH <sub>4</sub> -N) Concentration	1,485	mg/L	1,485	mg/L
Soluble COD, degradable (estimate)	500	mg/L	500	mg/L
Suspended Solids Concentration (TSS)	500	mg/L	500	mg/L
Soluble COD, degradable Load	774	kg/d	1,707	lb/day
Suspended Solids Load (TSS)	774	kg/d	1,707	lb/day
Alkalinity Concentration	4,677	mg/L	4,677	mg/L
Alkalinity Load	7,243	kg/d	15,968	lb/day
<b>DEMON® Anammox Tank Information</b>				
Number of tanks	2	in parallel	2	in parallel
Max. water depth	6.40	m	21.0	ft
Total volume per DEMON® Anammox Reactor	1142	m <sup>3</sup>	40,341	ft <sup>3</sup>
Length of Each DEMON® Anammox Treatment Reactor	14.6	m	48	ft
Width of Each DEMON® Anammox Treatment Reactor	12.2	m	40	ft
Total Treatment Volume Provided	2,285	m <sup>3</sup>	80,683	ft <sup>3</sup>
<b>Influent Feeding Design</b>				
Feeding pump per tank	47	m <sup>3</sup> /h	208	gpm
<b>Design of aeration system</b>				
<b>Biological Oxygen Requirements System Design</b>				
Actual Oxygen Requirements (AOR), operating conditions	3,949	kg O <sub>2</sub> /d	8,707	lb O <sub>2</sub> /d
Actual Oxygen Required (AOR) in DEMON® Anammox tank	118	kg O <sub>2</sub> /h	259	lb O <sub>2</sub> /h
<b>Aeration System &amp; Blower Design Air Flow Requirements</b>				
Design Air Flow (per DEMON® Anammox-tank)	1,416	Nm <sup>3</sup> /h	833	SCFM
Design Air Flow (per ALL TANKS)	2,832	Nm <sup>3</sup> /h	1,666	SCFM

Air flows are based on 21 ft operating water level and discharge pressure of 10.5 psig

Rough Footprint would be two (2) basins at 40 ft wide x 48 ft long x 21 ft SWD.



**DESIGN FOR 25C – Alt 2B & 2C - MM**

<b>Influent Flow and Wastewater Characteristics</b>	<b>Design</b>		<b>Design</b>	
Wastewater temperature in DEMON® Anammox-tank	25	°C	77	F
Daily water flow	1,649	m <sup>3</sup> /d	0.436	MGD
Ammonia (NH <sub>4</sub> -N) Load	2,449	kg/d	5,400	lb/day
Ammonia (NH <sub>4</sub> -N) Concentration	1,485	mg/L	1,485	mg/L
Soluble COD, degradable (estimate)	500	mg/L	500	mg/L
Suspended Solids Concentration (TSS)	500	mg/L	500	mg/L
Soluble COD, degradable Load	825	kg/d	1,818	lbday
Suspended Solids Load (TSS)	825	kg/d	1,818	lb/day
Alkalinity Concentration	4,677	mg/L	4,677	mg/L
Alkalinity Load	7,714	kg/d	17,007	lbday
<b>DEMON® Anammox Tank Information</b>				
Number of tanks	2	in parallel	2	in parallel
Max. water depth	6.40	m	21.0	ft
Total volume per DEMON® Anammox Reactor	1142	m <sup>3</sup>	40,341	ft <sup>3</sup>
Length of Each DEMON® Anammox Treatment Reactor	14.6	m	48	ft
Width of Each DEMON® Anammox Treatment Reactor	12.2	m	40	ft
Total Treatment Volume Provided	2,285	m <sup>3</sup>	80,683	ft <sup>3</sup>
<b>Influent Feeding Design</b>				
Feeding pump per tank	50	m <sup>3</sup> /h	222	gpm
<b>Design of aeration system</b>				
<b>Biological Oxygen Requirements System Design</b>				
Actual Oxygen Requirements (AOR), operating conditions	4,445	kg O <sub>2</sub> /d	9,799	lb O <sub>2</sub> /d
Actual Oxygen Required (AOR) in DEMON® Anammox tank	132	kg O <sub>2</sub> /h	292	lb O <sub>2</sub> /h
<b>Aeration System &amp; Blower Design Air Flow Requirements</b>				
Design Air Flow (per DEMON® Anammox-tank)	1,594	Nm <sup>3</sup> /h	938	SCFM
Design Air Flow (per ALL TANKS)	3,188	Nm <sup>3</sup> /h	1,876	SCFM

Air flows are based on 21 ft operating water level and discharge pressure of 10.5 psig

Rough Footprint would be two (2) basins at 40 ft wide x 48 ft long x 21 ft SWD.

**DESIGN FOR 25C – Alt 3A - MM**

<b>Influent Flow and Wastewater Characteristics</b>	<b>Design</b>		<b>Design</b>	
Wastewater temperature in DEMON® Anammox-tank	25	°C	77	F
Daily water flow	1,875	m <sup>3</sup> /d	0.495	MGD
Ammonia (NH <sub>4</sub> -N) Load	2,785	kg/d	6,140	lb/day
Ammonia (NH <sub>4</sub> -N) Concentration	1,485	mg/L	1,485	mg/L
Soluble COD, degradable (estimate)	500	mg/L	500	mg/L
Suspended Solids Concentration (TSS)	500	mg/L	500	mg/L
Soluble COD, degradable Load	938	kg/d	2,067	lbday
Suspended Solids Load (TSS)	938	kg/d	2,067	lb/day
Alkalinity Concentration	4,677	mg/L	4,677	mg/L
Alkalinity Load	8,771	kg/d	19,338	lbday
<b>DEMON® Anammox Tank Information</b>				
Number of tanks	2	in parallel	2	in parallel
Max. water depth	6.40	m	21.0	ft
Total volume per DEMON® Anammox Reactor	1426	m <sup>3</sup>	50,367	ft <sup>3</sup>
Length of Each DEMON® Anammox Treatment Reactor	18.3	m	60	ft
Width of Each DEMON® Anammox Treatment Reactor	12.2	m	40	ft
Total Treatment Volume Provided	2,853	m <sup>3</sup>	100,734	ft <sup>3</sup>
<b>Influent Feeding Design</b>				
Feeding pump per tank	57	m <sup>3</sup> /h	252	gpm
<b>Design of aeration system</b>				
<b>Biological Oxygen Requirements System Design</b>				
Actual Oxygen Requirements (AOR), operating conditions	4,783	kg O <sub>2</sub> /d	10,545	lb O <sub>2</sub> /d
Actual Oxygen Required (AOR) in DEMON® Anammox tank	142	kg O <sub>2</sub> /h	314	lb O <sub>2</sub> /h
<b>Aeration System &amp; Blower Design Air Flow Requirements</b>				
Design Air Flow (per DEMON® Anammox-tank)	1,715	Nm <sup>3</sup> /h	1,009	SCFM
Design Air Flow (per ALL TANKS)	3,429	Nm <sup>3</sup> /h	2,018	SCFM

Air flows are based on 21 ft operating water level and discharge pressure of 10.5 psig

Rough Footprint would be two (2) basins at 40 ft wide x 60 ft long x 21 ft SWD.

**DESIGN FOR 25C – Alt 4B &4D - MM**

<b>Influent Flow and Wastewater Characteristics</b>	<b>Design</b>		<b>Design</b>	
	Wastewater temperature in DEMON® Anammox-tank	25	°C	77
Daily water flow	773	m <sup>3</sup> /d	0.204	MGD
Ammonia (NH <sub>4</sub> -N) Load	1,148	kg/d	2,530	lb/day
Ammonia (NH <sub>4</sub> -N) Concentration	1,485	mg/L	1,485	mg/L
Soluble COD, degradable (estimate)	500	mg/L	500	mg/L
Suspended Solids Concentration (TSS)	500	mg/L	500	mg/L
Soluble COD, degradable Load	386	kg/d	852	lb/day
Suspended Solids Load (TSS)	386	kg/d	852	lb/day
Alkalinity Concentration	4,677	mg/L	4,677	mg/L
Alkalinity Load	3,614	kg/d	7,968	lb/day
<b>DEMON® Anammox Tank Information</b>				
Number of tanks	1	in parallel	1	in parallel
Max. water depth	6.40	m	21.0	ft
Total volume per DEMON® Anammox Reactor	1142	m <sup>3</sup>	40,341	ft <sup>3</sup>
Length of Each DEMON® Anammox Treatment Reactor	14.6	m	48	ft
Width of Each DEMON® Anammox Treatment Reactor	12.2	m	40	ft
Total Treatment Volume Provided	1,142	m <sup>3</sup>	40,341	ft <sup>3</sup>
<b>Influent Feeding Design</b>				
Feeding pump per tank	47	m <sup>3</sup> /h	208	gpm
<b>Design of aeration system</b>				
<b>Biological Oxygen Requirements System Design</b>				
Actual Oxygen Requirements (AOR), operating conditions	1,971	kg O <sub>2</sub> /d	4,345	lb O <sub>2</sub> /d
Actual Oxygen Required (AOR) in DEMON® Anammox tank	117	kg O <sub>2</sub> /h	259	lb O <sub>2</sub> /h
<b>Aeration System &amp; Blower Design Air Flow Requirements</b>				
Design Air Flow (per DEMON® Anammox-tank)	1,413	Nm <sup>3</sup> /h	832	SCFM

Air flows are based on 21 ft operating water level and discharge pressure of 10.5 psig

Rough Footprint would be one (1) basin at 40 ft wide x 48 ft long x 21 ft SWD.

**WWW Scope of Supply Alt 1, Alt 2B & 2C**

- Design & Engineering for System
- Two (2) – 40 ft wide x 5 ft deep x 18 ft tall internal settling zone made from Polypropylene
- Eighty-four (84) Messner Aeration panels for the reactor
- Four (4) SS 304L Drop pipe with manifold to feed Messner panels
- Two (2) DEMON® Biomass Separation System
- Three (3) submersible pumps (two duty + one standby) rated at 50 gpm and 5 HP motor with VFD's on each pump (operated 8 hrs per day)
- Three (3) Radar type level control for each DEMON® Tank & EQ Tank
- Three (3) influent feed pumps to the DEMON® reactor each rated for 225 gpm with VFD's on each pump. (operated 12 - 24 hrs per day) (2 duty + 1 standby)
- Four (4) Positive Displacement blowers (938 SCFM each) with VFD's on each blower (100 HP motors) (operated 14 hrs per day at design load) – (2 Duty + 2 Standby)
- Four (4) – 9.0 HP side mounted mixers with VFD's for each mixer (operated 6 hr/day)
- Seed Sludge for start-up of system delivered to the site
- DEMON® Control program with panel with VFD's for blowers, submersible pump and mixers
- Two (2) pH and DO probe with two (2) SC1000 controller
- Two (2) Conductivity probe with two (2) SC200 controller
- Two (2) Air flow insertion meter and six (6) water flow magnetic meters
- Inspection, start up and training services (5 trips / 20 days)
- 3-4 months of off-site / remote monitoring services
- **Estimated Price for above scope of supply: \$3,000,000 USD**

**Items not included:**

EQ Tank sized for 3 – 4 hours of HRT based on continuous dewatering  
DEMON® tanks  
Unloading, storage, installation of equipment  
Electrical connections and interconnecting piping

### **WWW Scope of Supply Alt 3A**

- Design & Engineering for System
- Two (2) – 40 ft wide x 5 ft deep x 18 ft tall internal settling zone made from Polypropylene
- Eighty-eight (88) Messner Aeration panels for the reactor
- Four (4) SS 304L Drop pipe with manifold to feed Messner panels
- Two (2) DEMON® Biomass Separation System
- Three (3) submersible pumps (two duty + one standby) rated at 50 gpm and 5 HP motor with VFD's on each pump (operated 8 hrs per day)
- Three (3) Radar type level control for each DEMON® Tank & EQ Tank
- Three (3) influent feed pumps to the DEMON® reactor each rated for 260 gpm with VFD's on each pump. (operated 12 - 24 hrs per day) (2 duty + 1 standby)
- Four (4) Positive Displacement blowers (1,010 SCFM each) with VFD's on each blower (100 HP motors) (operated 14 hrs per day at design load) – (2 Duty + 2 Standby)
- Four (4) – 12.2 HP side mounted mixers with VFD's for each mixer (operated 6 hr/day)
- Seed Sludge for start-up of system delivered to the site
- DEMON® Control program with panel with VFD's for blowers, submersible pump and mixers
- Two (2) pH and DO probe with two (2) SC1000 controller
- Two (2) Conductivity probe with two (2) SC200 controller
- Two (2) Air flow insertion meter and six (6) water flow magnetic meters
- Inspection, start up and training services (5 trips / 20 days)
- 3-4 months of off-site / remote monitoring services
- **Estimated Price for above scope of supply: \$3,100,000 USD**

### **Items not included:**

EQ Tank sized for 3 – 4 hours of HRT based on continuous dewatering

DEMON® tanks

Unloading, storage, installation of equipment

Electrical connections and interconnecting piping

#### **WWW Scope of Supply Alt 4**

- Design & Engineering for System
- One (1) – 40 ft wide x 5 ft deep x 18 ft tall internal settling zone made from Polypropylene
- Thirty-six (36) Messner Aeration panels for the reactor
- One (1) SS 304L Drop pipe with manifold to feed Messner panels
- One (1) DEMON® Biomass Separation System
- Two (2) submersible pumps (one duty + one standby) rated at 50 gpm and 5 HP motor with VFD's on each pump (operated 8 hrs per day)
- Two (2) Radar type level control for each DEMON® Tank & EQ Tank
- Two (2) influent feed pumps to the DEMON® reactor each rated for 210 gpm with VFD's on each pump. (operated 12 - 24 hrs per day) (1 duty + 1 standby)
- Two (2) Positive Displacement blowers (832 SCFM each) with VFD's on each blower (75 HP motors) (operated 14 hrs per day at design load) – (1 Duty + 1 Standby)
- Two (2) – 9.0 HP side mounted mixers with VFD's for each mixer (operated 6 hr/day)
- Seed Sludge for start-up of system delivered to the site
- DEMON® Control program with panel with VFD's for blowers, submersible pump and mixers
- One (1) pH and DO probe with one (1) SC1000 controller
- One (1) Conductivity probe with one (1) SC200 controller
- One (1) Air flow insertion meter and three (3) water flow magnetic meters
- Inspection, start up and training services (5 trips / 20 days)
- 3-4 months of off-site / remote monitoring services
- **Estimated Price for above scope of supply: \$1,850,000 USD**

#### **Items not included:**

EQ Tank sized for 3 – 4 hours of HRT based on continuous dewatering

DEMON® tank

Unloading, storage, installation of equipment

Electrical connections and interconnecting piping

## **Attachment E: Scenario 4 Alternatives Cost Analysis and Evaluation Results**

---





**Table E-1. Summary of Capital Costs for West Point Alternatives (Scenario 4) <sup>a, b</sup>**

Alternatives	Estimated probable cost of construction bid	Other construction cost	Total direct construction cost	Total indirect non-construction cost	Total Project Cost	Total project cost range	
						Low (-50 percent)	High (+300 percent)
Alt 4A: MLE	\$443,180,000	\$94,530,000	\$537,710,000	\$463,540,000	\$1,001,250,000	\$500,630,000	\$4,005,000,000
Alt 4C: MLE + sidestream bioaugmentation	\$459,540,000	\$98,020,000	\$557,560,000	\$479,310,000	\$1,036,870,000	\$518,440,000	\$4,147,480,000
Alt 4D: 4SMB + sidestream anammox	\$471,880,000	\$100,660,000	\$572,540,000	\$491,180,000	\$1,063,720,000	\$531,860,000	\$4,254,880,000
Alt 4E: 4SMB + sidestream bioaugmentation	\$468,330,000	\$99,900,000	\$568,230,000	\$487,770,000	\$1,056,000,000	\$528,000,000	\$4,224,000,000

a. Unescalated, undiscounted costs in 2020 dollars.

b. For all scenario 4 alternatives, West Point secondary treatment capacity is reduced. Costs shown do not include any cost for a greenfield treatment plant and necessary modifications in the collection system to make up for the lost capacity.

**Table E-2. Summary of Annual O&M Costs for West Point Alternatives (Scenario 4) <sup>a, b</sup>**

Alternatives	Annual electricity cost	Annual chemical cost	Annual additional FTE cost	Total annual O&M costs
Alt 4A: MLE	\$1,178,000	\$3,925,000	\$204,000	\$5,307,000
Alt 4C: MLE + sidestream bioaugmentation	\$1,307,000	\$4,270,000	\$306,000	\$5,883,000
Alt 4D: 4SMB + sidestream anammox	\$1,146,000	\$3,127,000	\$408,000	\$4,681,000
Alt 4E: 4SMB = sidestream bioaugmentation	\$1,360,000	\$3,947,000	\$408,000	\$5,715,000

a. Unescalated, undiscounted costs in 2020 dollars. Only electrical, chemical, and additional FTE costs for secondary system and sidestream processes are included.

b. For all scenario 4 alternatives, West Point secondary treatment capacity is reduced. Costs shown do not include any cost to operate a greenfield treatment plant and any necessary changes in the collection system to make up for the lost capacity.



Table E-3. Summary of Life-Cycle Costs for West Point Alternatives (Scenario 4) <sup>a, b</sup>					
Alternatives	Capital costs	O&M costs	NPV	TN removed (lb) <sup>c</sup>	Cost per lb N removed <sup>d</sup>
Alt 4A: MLE	\$1,001,250,000	\$106,140,000	(\$825,790,000)	69,249,700	\$11.92
Alt 4C: MLE + sidestream bioaugmentation	\$1,036,870,000	\$117,670,000	(\$859,770,000)	74,676,700	\$11.51
Alt 4D: 4SMB + sidestream anammox	\$1,063,720,000	\$93,620,000	(\$865,960,000)	75,189,100	\$11.52
Alt 4E: 4SMB + sidestream bioaugmentation	\$1,056,000,000	\$114,290,000	(\$872,340,000)	76,929,900	\$11.34

a. Unescalated, undiscounted costs in 2020 dollars.

b. For all scenario 4 alternatives, West Point secondary treatment capacity is reduced. Costs shown do not include any cost to construct and operate a greenfield treatment plant and necessary modifications in the collection system to make up for the lost capacity.

c. Total nitrogen load removed calculated from the difference between the annual raw influent TKN load and plant effluent nitrogen load, both based on current rated plant influent flows and loadings, multiplied by 20 for the 20-year life-cycle period.

d. Cost per lb N removed calculated by dividing the 20-year NPV by the total N removed.

Table E-4. Comparison of Alternatives—Modeling and LCCA Results (Scenario 4)					
Alternative		4A	4C	4D	4E
Scenario modifications or effluent limits/targets		Year-round N removal, effluent TIN limit of 8 mg/L (identify reduced secondary treatment capacity)			
Alternative description		MLE	MLE + sidestream bioaugmentation	4SMB + sidestream anammox	4SMB + sidestream bioaugmentation
Parameter	Units	Value			
<b>Cost estimates and LCCA results <sup>a</sup></b>					
Capital cost (total project cost) <sup>b</sup>	-	\$1,001,250,000	\$1,036,870,000	\$1,063,720,000	\$1,056,000,000
O&M cost (20-year) <sup>b, c</sup>	-	\$106,140,000	\$117,670,000	\$93,620,000	\$114,290,000
NPV (20-year)	-	(\$825,790,000)	(\$859,770,000)	(\$865,960,000)	(\$872,340,000)
Power consumption	kWh/yr	15,081,900	16,735,000	14,670,900	17,411,000
<b>Anticipated performance</b>					
Lost plant capacity (peak month flow)	mgd	117.0	110.0	110.0	108.0
Effluent TIN, summer average	mg/L	6.6	6.4	2.9	2.6
Effluent TIN, winter average	mg/L	8.7	8.6	10.9	10.9
TN removal efficiency, summer average	-	78%	78%	88%	89%
TN removal efficiency, winter average	-	61%	62%	54%	54%
TN removal efficiency, annual average	-	69%	70%	70%	71%



<b>Table E-4. Comparison of Alternatives—Modeling and LCCA Results (Scenario 4)</b>					
<b>Alternative</b>		<b>4A</b>	<b>4C</b>	<b>4D</b>	<b>4E</b>
Scenario modifications or effluent limits/targets		Year-round N removal, effluent TIN limit of 8 mg/L (identify reduced secondary treatment capacity)			
Alternative description		MLE	MLE + sidestream bioaugmentation	4SMB + sidestream anammox	4SMB + sidestream bioaugmentation
Parameter	Units	Value			
TN removed, annual average	lb/d	9,486	10,230	10,300	10,538
TN removed over 20-year period	lb	69,249,700	74,676,700	75,189,100	76,929,900
Cost of N removal <sup>d</sup>	\$/lb N	\$11.92	\$11.51	\$11.52	\$11.34
<b>Biosolids impacts</b>					
WAS production, peak month	lb TSS/d	47,549	54,163	44,595	52,942
Biosolids production, peak month	DT/d	21	23	22	23
<b>Sustainability analysis results</b>					
GHG emissions, nitrous oxide	CO <sub>2</sub> e MT/yr	2,023	2,152	6,848	6,717
GHG emissions, energy	CO <sub>2</sub> e MT/yr	134	149	131	155
GHG emissions, chemicals	CO <sub>2</sub> e MT/yr	8,700	9,242	8,281	9,042
GHG emissions, total	CO <sub>2</sub> e MT/yr	10,857	11,543	15,259	15,914
<b>Other considerations</b>					
Implementation timeframe <sup>e</sup>	-	10–12 years	10–12 years	10–12 years	10–12 years
Site layout issues/constraints	-	See notes on site layouts.			
Implementation challenges or constructability considerations	-				

a. For all scenario 4 alternatives, West Point secondary treatment capacity is reduced. Costs shown do not include any cost to construct and operate a greenfield treatment plant and necessary modifications in the collection system to make up for the lost capacity.

b. Capital and O&M costs are presented in 2020 dollars.

c. O&M costs are for electricity, chemicals, and additional FTEs only.

d. Cost of N removal calculated as TN removed over 20-year period divided by 20-year NPV.

e. Estimated duration for planning, design, and construction.



Alternative		4A	4C	4D	4E
Scenario modifications or effluent limits/targets		Year-round N removal, effluent TIN limit of 8 mg/L (identify reduced secondary treatment capacity)			
Alternative description		MLE	MLE + sidestream bioaugmentation	4SMB + sidestream anammox	4SMB + sidestream bioaugmentation
Scoring criteria	Weight <sup>b</sup>	Score <sup>a</sup>			
Technology status	1	10	10	10	10
Effluent N load reduction	3	3	3	4	4
Load variation impact	1	6	6	6	6
Flow variation impact	2	6	6	6	6
Space for future expansion	3	5	4	4	4
Plant capacity	3	2	3	3	3
Impacts to other processes	2	8	6	8	6
Truck traffic	2	7	7	7	7
GHG emissions	2	4	4	3	3
Resource recovery <sup>c</sup>	1	2	2	3	3
CEC and toxics removal potential <sup>d</sup>	1	3	3	3	3
Capital cost	3	6	5	4	4
O&M cost	3	5	4	7	4
Supplemental carbon source flexibility	2	5	4	3	3
Risks	2	1	1	1	1
Constructability	3	8	6	8	7
Operational complexity	2	8	7	7	7
<b>Total un-weighted score</b>		<b>89</b>	<b>81</b>	<b>87</b>	<b>81</b>
<b>Total weighted score</b>		<b>186</b>	<b>166</b>	<b>182</b>	<b>166</b>
Notes:					
a. Score of 1 to 10, where 10 represents the greatest benefit or lowest cost, footprint, emissions, etc.					
b. Score of 1 to 3, where 3 represents the highest weighting factor.					
c. Resource recovery includes nutrient recovery (N or P), flexibility for future reclaimed water production (TN limits, filtration, etc.), energy recovery, etc.					
d. CEC and toxics removal potential only considers the mainstream activated sludge process. In general, longer SRT systems (MBR) have higher potential removal, while blended options (parallel MBR/CAS systems) or seasonal N removal options have lower potential.					

Figure E-1. Comparison of alternatives – scoring results (scenario 4)



## Appendix F: TM 3B—South Plant

---

This page intentionally left blank.



# Technical Memorandum

701 Pike Street, Suite 1200  
Seattle, WA 98101-2310

Phone: 206-624-0100  
Fax: 206-749-2200

Prepared for: King County

Project Title: King County Flows and Loads–Nitrogen Removal Study

Project No.: 151084.464

## Technical Memorandum 3B

Subject: South Plant Site-Specific Nitrogen Removal Analysis of Planning Alternatives

Date: September 9, 2020

To: Eron Jacobson, King County Nitrogen Removal Task Lead

From: Rick Kelly, Brown and Caldwell Nitrogen Removal Task Lead

Prepared by:

Patricia Tam, P.E., WA License. No. 35722, Expiration 9/10/2021

Matt Winkler, P.E., WA License. No. 52196, Expiration 3/4/2021

Reviewed by:

Richard Kelly, Ph.D., P.E., WA License. No. 45235, Expiration 6/3/2021



# Table of Contents

Section 1: Introduction .....	1
Section 2: Basis of Analysis and Assumptions .....	1
Section 3: Discussion of Alternatives .....	4
3.1 Scenario 1 – Sidestream Treatment Only .....	6
3.1.1 Alternative 1A – Existing Mainstream + Sidestream Anammox .....	6
3.2 Scenario 2 – Seasonal Nitrogen Removal with Effluent TIN Limit of 8 mg/L .....	8
3.2.1 Alternative 2A – MLE + Tertiary Denitrifying Fixed-Film System .....	8
3.2.2 Alternative 2B – MLE + Sidestream Anammox .....	11
3.3 Scenario 3 – Year-round Nitrogen Removal with Effluent TIN Limit of 8 mg/L Equivalent .....	12
3.3.1 Alternative 3A – 4SMB + Sidestream Anammox .....	13
3.3.2 Alternative 3B – 4SMB + Sidestream Bioaugmentation .....	15
3.4 Scenario 4 – Year-round Nitrogen Removal with Effluent TIN of 3 mg/L .....	17
3.4.1 Alternative 4A – 4SMB + Sidestream Anammox .....	17
3.4.2 Alternative 4C – MLE + Tertiary Denitrifying Fixed-Film System .....	19
3.4.3 Alternative 4D – Existing Mainstream + Tertiary Nitrifying/Denitrifying Fixed-Film System .....	21
3.4.4 Alternative 4E – 4SMB/MBR + Sidestream Anammox .....	23
3.5 Supplemental Carbon Addition Discussion .....	25
3.5.1 Unthickened Primary Sludge Fermenter .....	26
3.5.2 Pre-Thickened Primary Sludge Fermenter .....	26
3.6 Hydraulic Risks Discussion .....	26
Section 4: Cost Analysis .....	27
4.1 Capital Costs .....	27
4.1.1 Site-Specific Capital Cost Assumptions .....	28
4.1.2 Summary of Capital Costs .....	28
4.2 O&M Costs .....	30
4.2.1 Site-Specific O&M Cost Assumptions .....	30
4.2.2 Summary of O&M Costs .....	30
4.3 Life-Cycle Costs .....	31
Section 5: Comparison and Ranking of Alternatives .....	32
5.1 Evaluation Criteria and Weighting .....	32
5.1.1 Technology Status .....	33
5.1.2 Effluent Nitrogen Load Reduction .....	33
5.1.3 Load Variation Impact .....	33
5.1.4 Flow Variation Impact .....	33
5.1.5 Space for Future Expansion .....	33
5.1.5 Impacts to Other Processes .....	33
5.1.7 GHG Emissions .....	33



5.1.8 Resource Recovery .....34

5.1.9 CEC and Toxics Removal Potential .....34

5.1.10 Capital Cost.....34

5.1.11 O&M Cost.....34

5.1.12 Supplementary Carbon Source Flexibility .....34

5.1.13 Risks.....35

5.1.14 Constructability.....35

5.1.15 Operational Complexity .....35

5.2 Evaluation Results .....35

Section 6: Summary .....39

Attachment A: Site Layouts .....A-1

Attachment B: Greenhouse Gas Emissions Results and Literature Review of Nitrous Oxide Emission Factors  
.....B-1

Attachment C: Basis of Capital Cost Estimates of Alternatives.....C-1

Attachment D: Budgetary Proposals for Equipment .....D-1

## List of Figures

---

Figure 1. Process flow schematic for Alternative 1A – existing mainstream + sidestream anammox.....6

Figure 2. Process flow schematic for Alternative 2A – MLE + tertiary denitrifying fixed-film system .....9

Figure 3. Process flow schematic for Alternative 2B – MLE + sidestream anammox.....11

Figure 4. Process flow schematic for Alternative 3A – 4SMB + sidestream anammox .....13

Figure 5. Process flow schematic for Alternative 3B – 4SMB + sidestream bioaugmentation .....15

Figure 6. Process flow schematic for Alternative 4A – 4SMB + sidestream anammox .....17

Figure 7. Process flow schematic for Alternative 4C – MLE + tertiary denitrifying fixed-film system.....19

Figure 8. Process flow schematic for Alternative 4D – existing mainstream + tertiary nitrifying/ denitrifying  
fixed-film system .....21

Figure 9. Process flow schematic for Alternative 4E – 4SMB/MBR + sidestream anammox .....23

Figure 10. Comparison of estimated GHG emissions.....36

Figure 11. Comparison of alternatives – scoring results.....38



## List of Tables

---

Table 1. South Plant Design Flows and Loadings for Nitrogen Removal Analysis .....	2
Table 2. Summary of Selected Alternatives for South Plant Nitrogen Removal Scenarios .....	5
Table 3. South Plant Nitrogen Removal Modeling Results and System Sizing for Alternative 1A .....	7
Table 4. South Plant GHG Emissions for Alternative 1.....	7
Table 5. South Plant Nitrogen Removal Modeling Results and System Sizing for Alternative 2A .....	9
Table 6. South Plant GHG Emissions for Alternative 2A.....	10
Table 7. South Plant Nitrogen Removal Modeling Results and System Sizing for Alternative 2B.....	11
Table 8. South Plant GHG Emissions for Alternative 2B.....	12
Table 9. South Plant Nitrogen Removal Modeling Results and System Sizing for Alternative 3A.....	13
Table 10. South Plant GHG Emissions for Alternative 3A.....	14
Table 11. South Plant Nitrogen Removal Modeling Results and System Sizing for Alternative 3B .....	16
Table 12. South Plant GHG Emissions for Alternative 3B .....	16
Table 13. South Plant Nitrogen Removal Modeling Results and System Sizing for Alternative 4A.....	18
Table 14. South Plant GHG Emissions for Alternative 4A.....	19
Table 15. South Plant Nitrogen Removal Modeling Results and System Sizing for Alternative 4C .....	20
Table 16. South Plant GHG Emissions for Alternative 4C .....	21
Table 17. South Plant Nitrogen Removal Modeling Results and System Sizing for Alternative 4D .....	21
Table 18. South Plant GHG Emissions for Alternative 4D .....	22
Table 19. South Plant Nitrogen Removal Modeling Results and System Sizing for Alternative 4E.....	23
Table 20. South Plant GHG Emissions for Alternative 4E.....	25
Table 21. Summary of Capital Costs for South Plant Alternatives.....	29
Table 22. Summary of Annual O&M Costs for South Plant Alternatives .....	31
Table 23. Summary of Life-Cycle Costs for South Plant Alternatives .....	32
Table 24. Comparison of Alternatives – Modeling and LCCA Results .....	37



## List of Abbreviations

4SMB	4-Stage Modified Bardenpho	MBR	membrane bioreactor
AOB	ammonia-oxidizing bacteria	MLE	Modified Ludzack–Ettinger
A/O	anaerobic/oxic	MG	million gallons
BAF	biologically active filter	mgd	million gallons per day
BAR	bioaugmentation reaeration	mg/L	milligrams per Liter
BOD	biochemical oxygen demand	ML	mixed liquor
BOE	Basis of Estimates	MT	metric tons
CAS	conventional activated sludge	MT/yr	metric tons per year
CEC	compounds of emerging concern	N	nitrogen
CO <sub>2</sub>	carbon dioxide	NOB	nitrite-oxidizing bacteria
CO <sub>2</sub> e	carbon dioxide equivalent	NPV	net present value
COD	chemical oxygen demand	O&M	operations and maintenance
County	King County	PAO	polyphosphate accumulating organism
DAFT	dissolved air flotation thickener	PE	primary effluent
DT	dry tons	Q	Flow rate
ft	foot/feet	RAS	return activated sludge
FTE	full-time equivalent	SCAP	Strategic Climate Action Plan
gal	gallon(s)	scfm	standard cubic feet per minute
gfd	gallons per square foot per day	SRT	solids retention time
gpd	gallons per day	SWD	sidewater depth
GHG	greenhouse gas	TIN	total inorganic nitrogen
HPO	high-purity oxygen	TKN	total Kjeldahl nitrogen
HRT	hydraulic retention time	TM	technical memorandum
IMLR	internal mixed liquor recycle	TN	total nitrogen
IPCC	International Panel for Climate Change	TSS	total suspended solids
IPS	influent pump station	VFA	volatile fatty acids
kWh	kilowatt hour	WAS	waste activated sludge
lb/d	pounds per day	WTD	Wastewater Treatment Division
LCCA	life-cycle cost analysis		



## Section 1: Introduction

This technical memorandum (TM) documents the evaluation of selected planning-level alternatives for nitrogen removal at the South Treatment Plant (South Plant). This evaluation follows the initial technology screening analysis (documented in the *Nitrogen Removal Technologies Technical Summaries and Pre-Screening TM* [TM 1]), and the subsequent development of four nitrogen removal scenarios and selection of alternatives for further evaluation (documented in the *South Plant Nitrogen Removal Technology Combinations Review and Screening TM* [TM 2]). Each selected alternative was modeled using the previously calibrated biological process simulator BioWin to provide sizing information for expanding existing treatment processes and/or adding new processes. Planning-level information was developed, including:

- Site layouts
- Capital costs
- Operating costs
- Life-cycle cost analyses (LCCAs)
- Anticipated treatment performance and effluent quality related to nitrogen removal
- Estimated biosolids production
- Sustainability analysis results expressed as greenhouse gas (GHG) emissions

Nine alternatives were compared using a matrix of evaluation criteria that was adapted and updated from the previous alternatives screening process. The results were presented in the South Treatment Plant Nitrogen Removal Workshop 2 with King County's (County) Wastewater Treatment Division (WTD) staff on January 7, 2020. This TM includes changes made to the analysis based on feedback and discussion from the workshop. The final results include a range of costs, GHG emissions, and other operational impacts for alternatives associated with each nitrogen removal scenario.

In general, the results of this evaluation are high-level in nature. A more detailed analysis would be needed to confirm or refine the process sizing and to re-evaluate alternatives selection during facility planning and subsequent design efforts.

## Section 2: Basis of Analysis and Assumptions

To develop the planning-level information for the analysis, the current rated design flows and loadings for South Plant were assumed (Table 1). The current rated design flows and loadings were selected as the basis for this evaluation based on discussion with the County. The different nitrogen removal scenarios considered for this analysis include both year-round and seasonal limits. As a result, peaking factors were assumed to calculate the corresponding flows and loadings under different seasonal conditions.



Table 1. South Plant Design Flows and Loadings for Nitrogen Removal Analysis		
Parameter	Value	Basis/Reference
<b>Design influent flows and loads</b>		Max month flows and loadings correspond to current rated capacities as shown in NPDES permit effective August 1, 2015
<b>Maximum month</b>		
Flow, mgd	144	
BOD, lb/d	251,000	
TSS, lb/d	235,000	
TKN, lb/d	54,700	Estimated from BOD/TKN ratio from 2017 wastewater characterization
<b>Peaking Factors</b>		
<b>Flow</b>		
Max month/average dry weather	1.88	
Max month/average wet weather	1.47	
<b>BOD</b>		Calculated from projections provided by King County in TM “South Plant Treatment Plant Peak Flow and Wasteload Projections 2010-2060” (January 2019)
Max month/average dry weather	1.28	
Max month/average wet weather	1.28	
<b>TSS</b>		
Max month/average dry weather	1.25	
Max month/average wet weather	1.25	
<b>Summer average flow and load</b>		Average dry weather flow and loads. Use for average summer period performance and operating costs
Flow, mgd	77	
BOD, lb/d	196,000	
TSS, lb/d	188,000	
TKN, lb/d	30,800	
<b>Winter/shoulder average flow and load</b>		Average wet weather flow and loads Use for average winter and shoulder period performance and operating costs
Flow, mgd	98	
BOD, lb/d	196,000	
TSS, lb/d	188,000	
TKN, lb/d	40,600	
<b>Shoulder average flow and max month load</b>		Average wet weather flow, max month load Use for sizing worst-case nitrification at minimum shoulder temperature for seasonal scenarios
Flow, mgd	98	
BOD, lb/d	251,000	
TSS, lb/d	235,000	
TKN, lb/d	54,700	
<b>Winter/shoulder max month flow and load</b>		Max month flow, max month load Use for sizing worst-case nitrification at minimum winter temperature for year-round scenarios
Flow, mgd	144	
BOD, lb/d	251,000	
TSS, lb/d	235,000	
TKN, lb/d	54,700	

BOD = biochemical oxygen demand

TSS = total suspended solids

mgd = million gallons per day

lb/d = pounds per day

Other assumptions used in modeling the different alternatives include:

- All modeling and sizing conducted for this study was based on the current rated flows and loads for South Plant. This was decided to effectively represent the costs of performing nitrogen removal for existing conditions. Further evaluation would be needed to assess impacts of operation at actual and projected flows and loads, as would typically be done for King County basis of design on capital projects.



- For scenarios with a seasonal nitrogen limit, the limit was assumed to apply between April and October. A “shoulder” period is defined as the controlling condition for seasonal nitrogen removal. April is considered the critical month for facility sizing because of the low wastewater temperature typically observed in that month and the potential for peak flows to occur, both of which impact the nitrification process.
- Some level of nitrifier inhibition was assumed based on model calibration from the South Plant capacity evaluation. For alternatives with the existing mainstream process, the same model kinetic coefficient values determined from the model calibration were used. For alternatives with new mainstream processes, the value for one of the kinetic coefficients is adjusted assuming that the nitrifier kinetics would be improved for alternatives that are fully nitrifying,
- In general, the modeling performed for this analysis provides a conservative estimate with modeling showing no nitrification during the winter for seasonal alternatives. Nitrification growth rate testing could be conducted during future planning or design to confirm nitrification kinetics for South Plant. Modeling would also need to be optimized during design to confirm requirements for seasonal transitions in and out of nitrification.
- Mixed liquor temperatures, based on effluent temperature data from July 2014 to December 2017, were assumed as follows:
  - Shoulder period: 16.8 degrees Celsius (°C) (average), 15.3°C (minimum)
  - Summer period: 21.5°C (average), 23.8°C (maximum)
  - Winter period: 16.2°C (average), 13.1°C (minimum)
- Secondary influent wastewater characteristics (except for BOD and TSS) were based on model calibration for 1) the December 2017 sampling data for the winter and shoulder period simulations and 2) July 2018 sampling data for the summer period simulations, adjusted for removal of centrate loads. The following calculated ratios for chemical oxygen demand (COD) to BOD and COD to total Kjeldahl nitrogen (TKN) were used:
  - COD to BOD = 2.07 (winter/shoulder), 1.77 (summer)
  - COD to TKN = 7.29 (winter/shoulder), 7.68 (summer)
- Centrate characteristics are based on December 2017 and July 2018 centrate sampling data.
- At least one aeration basin can be out of service during the summer period (not including the shoulder periods if seasonal nitrification is required).
- Except for Alternative 4E (conversion to membrane bioreactor [MBR] process), one secondary clarifier is assumed to be out of service during the shoulder and winter periods, and two pods plus one clarifier (9 clarifiers total) are assumed out of service during the summer period.
- For Alternative 4E, membrane basin sizing and membrane requirements were determined by assuming a peak flux rate of 10 gallons per square foot per day (gfd). This peak flux rate is similar to the peak hour membrane capacity of 28 mgd for the existing MBR system at the Brightwater Treatment Plant (Brightwater) based on peak flow test data from August 2013 to June 2015. A peak flux rate of 10 gfd is considerably lower than the typical design flux rate used by the membrane manufacturer. For example, Suez, which supplies the MBR equipment at Brightwater, recommends a peak design flux rate of 18.2 gfd at a design minimum temperature of 11°C. Budgetary proposals were obtained for both the 10-gfd flux limit and the manufacturer’s recommended peak design flux limit, but site layouts and cost estimating are based on the 10-gfd flux limit. Budgetary proposals for equipment are included in Attachment D.
- The technologies selected for the alternatives evaluated in this analysis were based on the state of the technologies during the technology screening phase of this work in 2019. Since that initial review, some



of the technologies that were screened out (such as hybrid fixed-film/ballast processes and membrane aerated biofilm reactor) have seen an increasing number of installations and their application could provide potential savings in footprint and costs. Re-assessment of those technologies was not conducted in this TM. It is recommended that those technologies be re-considered and reviewed in any future analysis and design.

In addition to biological process modeling, a high-level GHG inventory was completed for each evaluated alternative. This GHG inventory was estimated based on the following methods and assumptions:

- The accounting of GHG emissions considered only operation emissions as a result of indirect and direct emissions. No GHG emissions were accounted for during construction (concrete, materials, machinery, fuel consumption, etc.); however, it can be assumed that alternatives that require extensive amounts of concrete for construction are likely to have significantly higher purchasing-related emissions than alternatives that do not require extensive amounts of concrete.
- GHG emissions were estimated for the secondary, tertiary, and sidestream treatment processes only, and do not include emissions from other facilities/processes in the plant.
- Accounting of emissions included direct nitrous oxide emissions from treatment and indirect nitrous oxide emissions from effluent nitrogen discharge, as well as carbon dioxide (CO<sub>2</sub>) emissions from transportation and materials usage and energy consumption.
- CO<sub>2</sub> emissions for energy use were based on the energy-source profile provided by the County for South Plant. King County is currently contracted to purchase all-renewable electricity from Puget Sound Energy for South Plant. However, there is a risk that if electricity use increases from current usage significantly for a given alternative (especially those for Scenario 4 alternatives), the County may not be able to purchase all-renewable electricity or may need to pay an additional premium for the additional all-renewable electricity. This would increase either the GHG emissions or the operating costs for those alternatives.
- Biogenic carbon dioxide emissions were not considered as part of the inventory as per the International Panel for Climate Change (IPCC) carbon accounting protocol and framework.
- “Chapter 6 Nitrous Oxide Emissions from Domestic Wastewater” was used as the primary method for estimating emissions. This method can be found in the *2019 Refinement to the 2006 Guidelines for National Greenhouse Gas Inventories*.
- Nitrous oxide emission factors were developed from a comprehensive literature review of different studies (Attachment B).
- King County’s Strategic Climate Action Plan (SCAP) requires WTD to be carbon neutral for its operations- and purchasing-related GHG emissions by 2025. The updated 2020 SCAP will likely require capital projects to purchase offsets for their purchasing-related emissions. WTD’s current cost for purchasing offsets is \$10 per metric ton of carbon. The results of the GHG analysis are used for comparative purposes in this study, but it was not used to account for carbon offset costs in the LCCA due to the high-level nature of this analysis. A detailed GHG study should be completed as part of any future facility planning effort for South Plant.

## Section 3: Discussion of Alternatives

As a result of South Plant Nitrogen Removal Workshop 1 with County staff on May 30, 2019, four nitrogen removal scenarios and 12 alternatives were initially selected for the site-specific analysis for South Plant, as described in TM 2. Subsequently, one new alternative (4E) was added to scenario 4, and three alternatives (1B, 2C, 3C, and 4B) were eliminated from further analysis (reasons for adding or removing specific



alternatives are described in the following sections for each scenario). The scenarios and alternatives evaluated in this analysis of planning alternatives are summarized in Table 2.

<b>Table 2. Summary of Selected Alternatives for South Plant Nitrogen Removal Scenarios</b>	
<b>Alternative</b>	<b>Description</b>
<b>Scenario 1: Sidestream treatment only</b>	
1A	Existing mainstream + sidestream anammox
<b>Scenario 2: Seasonal N removal, effluent TIN limit of 8 milligrams per liter (mg/L)</b>	
2A	MLE + tertiary denitrifying fixed-film
2B	MLE + sidestream anammox
<b>Scenario 3: Year-round N removal, effluent TIN limit of 8-mg/L equivalent</b>	
3A	4SMB + sidestream anammox
3B	4SMB + sidestream bioaugmentation
<b>Scenario 4: Year-round N removal, effluent TIN limit of 3 mg/L</b>	
4A	4SMB + sidestream anammox
4C	MLE + tertiary denitrifying fixed-film
4D	Existing mainstream + tertiary nitrifying/denitrifying fixed-film
4E	4SMB/MBR + sidestream anammox

*N = nitrogen*

*TIN = total inorganic nitrogen*

*MLE = Modified Ludzack-Ettinger*

*4SMB = 4-Stage Modified Bardenpho*

The following sections discuss each of the alternatives, including process description, modeling results, facility sizing, major equipment requirements, site layouts, and GHG emissions. Site layouts for each alternative consist of an aerial photograph of the plant marked up to show new or modified facilities and approximate flow paths for major piping. All site layouts are provided in Attachment A.

A plant hydraulic profile analysis was not conducted as part of this evaluation. It is recommended that a hydraulic analysis be conducted to confirm the hydraulic capability or to add hydraulic improvements as needed during facility planning and detailed design. The following sections describe hydraulics/conveyance challenges associated with each alternative (if applicable). Section 3.6 provides additional discussion and a comparison of hydraulic risks for alternatives.



### 3.1 Scenario 1 – Sidestream Treatment Only

This scenario minimizes capital improvements but also provides the least nitrogen removal relative to other options. Two alternatives were initially investigated, one with sidestream anammox (Alternative 1A) and one with sidestream bioaugmentation (Alternative 1B); however, Alternative 1B was subsequently eliminated based on preliminary modeling demonstrating no nitrogen removal benefit from sidestream bioaugmentation during winter and shoulder periods when the plant has minimal or no mainstream nitrification, as well significant alkalinity consumption during summer operation with reduced nitrogen removal compared to sidestream anammox. Therefore, only Alternative 1A is included for this scenario, as described below.

#### 3.1.1 Alternative 1A – Existing Mainstream + Sidestream Anammox

In this alternative, the existing anaerobic selector-assisted activated sludge process would remain as the secondary treatment process. In the summer, the system would operate at higher sludge retention time (SRT) (6 days) to provide partial nitrification, consistent with the operating strategy employed in the summer in recent years, with nitrogen removal provided through denitrification of the return activated sludge (RAS) in passes 1A and 1B (first half of pass 1). An anammox-based sidestream process would be added to reduce ammonia loading from the centrate that is routed to the secondary system by converting it to nitrogen gas. The sidestream process would operate year-round. Figure 1 shows a process flow schematic for this alternative. The schematic shows separate tankage for centrate equalization and sedimentation. It may be possible to combine the two into a single tank, which will provide potential cost and footprint savings.

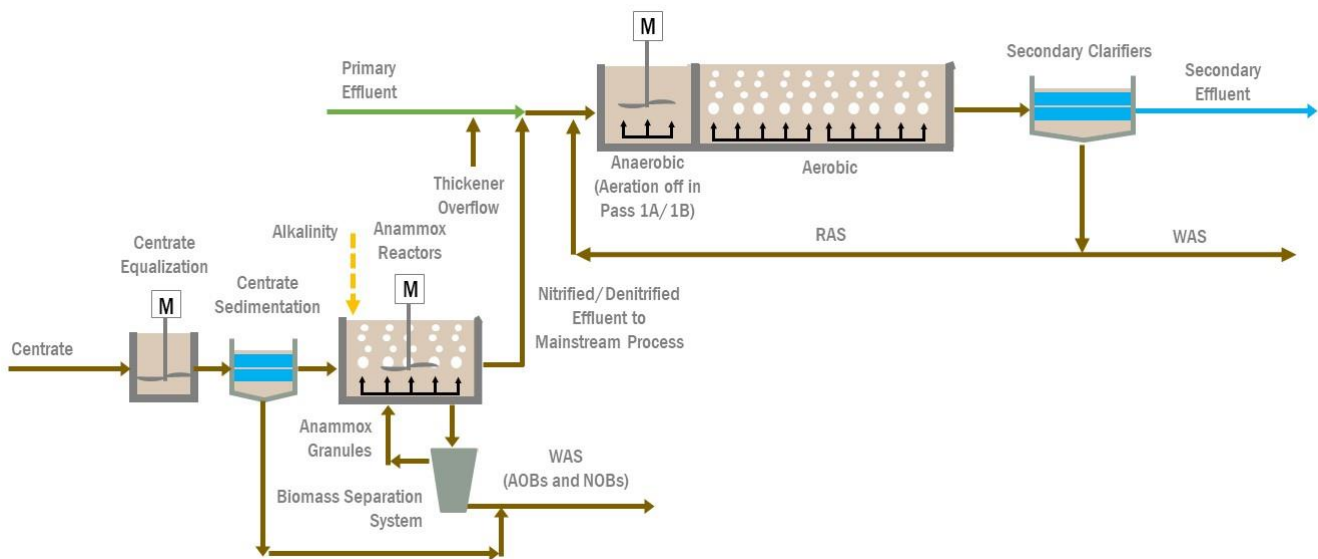

**Figure 1. Process flow schematic for Alternative 1A – existing mainstream + sidestream anammox**  
(AOB = ammonia-oxidizing bacteria, NOB = nitrite-oxidizing bacteria, WAS = waste activated sludge)

Table 3 summarizes the modeling results and sizing of major facilities and equipment for Alternative 1A.

Table 3. South Plant Nitrogen Removal Modeling Results and System Sizing for Alternative 1A	
Parameter	Value
Final effluent TIN, mg/L	
@ shoulder average wet weather flow and max month load	45
@ summer avg dry weather flow and load	18
@ winter avg wet weather flow and load	36
Overall TN removal, %	
@ shoulder average wet weather flow and max month load	23
@ summer avg dry weather flow and load	60
@ winter avg wet weather flow and load	24
Annual average	39
Annual average aeration requirements	
Aeration basin air flow, scfm	47,350
Annual average supplemental chemical requirements	
Alkalinity (25% caustic), gpd	460
Methanol, gpd	0
No. of new aeration basins	0
Side stream treatment	
Type	Anammox
Centrate equalization tank volume, gal	110,000
Centrate sedimentation tank volume, gal	207,000
Number of reactor tanks	2
Volume of reactor tank, gal	500,000

gal = gallon(s)

gpd = gallons per day

scfm = standard cubic feet per minute

TN = total nitrogen

A preliminary site layout for Alternative 1A is provided in Attachment A. The new sidestream treatment system and supplemental alkalinity system are assumed to be located in the area west of the dissolved air flotation thickeners (DAFTs).

**Challenges and Potential Risks.** The new facilities for this alternative can be constructed with relatively short implementation time and minimal impacts to the existing plant operations. This alternative, however, provides limited overall nitrogen removal, with average secondary effluent TIN concentrations well above 10 mg/L and an annual average TN removal of approximately 36 percent (as indicated by the results in Table 3).

Table 4 summarizes the estimated GHG emissions for Alternative 1A.

Table 4. South Plant GHG Emissions for Alternative 1	
Parameter	Value
GHG emissions carbon dioxide equivalent, metric tons per year (CO <sub>2</sub> e MT/yr)	
Nitrous oxide	13,200
Energy <sup>a</sup>	0
Chemicals	470
Total	13,600

MT = metric ton(s)

a. Per information provided by King County, GHG emissions associated with power consumption are assumed to be zero for this analysis because South Plant is now purchasing 100 percent renewable energy from Puget Sound Energy.



## 3.2 Scenario 2 – Seasonal Nitrogen Removal with Effluent TIN Limit of 8 mg/L

For this scenario, South Plant would provide seasonal (April through October) nitrogen removal, with a monthly average effluent TIN limit of 8 mg/L. Two alternatives were evaluated for this scenario, as described below. Both alternatives would use an MLE configuration, where the aeration basins are operated in MLE mode for seasonal nitrogen removal or anaerobic/oxic (A/O) mode during the winter when nitrogen removal would not be required. A/O mode is similar to the existing anaerobic selector mode at South Plant and supports biological phosphorus removal, which is often associated with fast settling mixed liquor. A/O mode is basically MLE without the internal mixed liquor recycle (IMLR) pumping, and A/O can be operated at lower SRTs when nitrification is not required. Therefore, winter operation in A/O mode reduces overall mainstream process volume requirements compared to year-round operation in MLE mode by reducing solids loading to the secondary clarifiers and typically improving mixed liquor settling characteristics. Seasonal transition to biological phosphorus removal with the A/O mode would be expected to require a few SRTs of operation in A/O mode to establish polyphosphate accumulating organisms (PAOs). Other potential strategies for speeding up or improving the transition to biological phosphorus removal, such as use of a sidestream bioaugmentation reactor for growing and seeding PAOs to the mainstream process, are not expected to be required but could be investigated during design.

An additional alternative using MLE with sidestream bioaugmentation (Alternative 2C) was also initially investigated but eliminated from further consideration after completing preliminary modeling and site layouts. Compared to Alternative 2B with sidestream anammox, sidestream bioaugmentation still required a similar mainstream process volume/footprint and would have had higher operating costs (higher methanol demands, aeration requirements, and WAS production). Sidestream bioaugmentation would also require complex tie-ins to the existing RAS system, whereas sidestream anammox could be implemented with minimal impacts to the mainstream process. Therefore, the County decided to eliminate Alternative 2C from this analysis.

### 3.2.1 Alternative 2A – MLE + Tertiary Denitrifying Fixed-Film System

In this alternative, the existing aeration basins would be re-configured to operate as an MLE process and a new tertiary denitrifying fixed-film system would be added to provide additional effluent nitrogen removal. Figure 2 shows a process flow schematic for this alternative. In an MLE process, the aeration basins consist of an unaerated (anoxic) zone followed by an aerated zone, with IMLR pumping from the aerated zone back to the anoxic zone. To operate in MLE mode, IMLR pumps and piping would need to be added to the existing basins at South Plant. For this analysis, a denitrifying biologically active filter (BAF) is assumed for the tertiary fixed-film system. The system would consist of filter cells with floating media, backwash tank and pumps, and associated controls and instrumentation. A tertiary feed pump station would be added to pump secondary effluent to the tertiary system. As there will be minimal carbon available in the secondary effluent, supplemental carbon in the form of methanol would be added to drive denitrification in the BAF. During the winter season, it is assumed that the tertiary system would be operated with partial flow but that there would be no methanol addition. For actual operation, the system would need to be transitioned into full denitrification several weeks ahead of the shoulder season. Requirements for winter operation and transition into tertiary denitrification modes would need to be optimized during design.

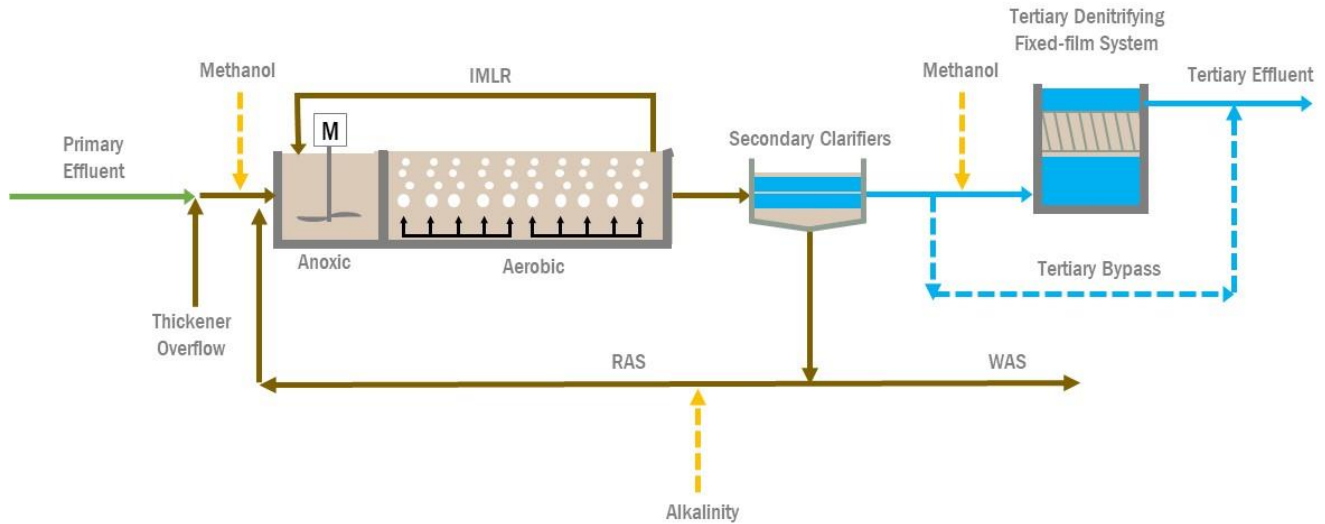

Figure 2. Process flow schematic for Alternative 2A – MLE + tertiary denitrifying fixed-film system

Table 5 summarizes the modeling results and sizing of major facilities and equipment for Alternative 2A.

Table 5. South Plant Nitrogen Removal Modeling Results and System Sizing for Alternative 2A	
Parameter	Value
Secondary effluent TIN, mg/L	
@ shoulder average wet weather flow and max month load	25
@ summer avg dry weather flow and load	17
@ winter avg wet weather flow and load	40
Final effluent TIN, mg/L <sup>a</sup>	
@ shoulder average wet weather flow and max month load	8
@ summer avg dry weather flow and load	8
@ winter avg wet weather flow and load	40
Overall TN removal, % <sup>b</sup>	
@ shoulder average wet weather flow and max month load	83
@ summer avg dry weather flow and load	80
@ winter avg wet weather flow and load	15
Annual average	43
Annual average aeration requirements	
Aeration basin air flow, scfm	42,500
Annual average supplemental chemical requirements	
Alkalinity (25% caustic), gpd	6,000
Methanol, gpd	1,450
New aeration basins <sup>c</sup>	
Number of new basins	2
Volume per basin, MG	4.27
Tertiary fixed-film system	
Number of denitrifying cells	10
Total cell volume, MG	1.89

- a. Final effluent concentrations including removals across the tertiary process during the shoulder and summer periods.
  - b. Overall removal accounts for removals across tertiary treatment during the summer and shoulder periods.
  - c. A sidewater depth of 22 ft was assumed for the new aeration basins.
- MG = million gallons

A preliminary site layout for Alternative 2A is provided in Attachment A. To reduce their footprint, the two new aeration basins, shown to be north of the existing basins, are assumed to have a sidewater depth (SWD) of 22 feet (ft) (compared to a SWD of approximately 15 ft for the existing basins). In addition, aeration air would be provided by new aeration blowers installed in a gallery adjacent to the new basins. These assumptions apply to all alternatives requiring new aeration basins. The existing north chlorine contact channel is assumed to be reconfigured to convey secondary effluent from the secondary clarifiers to the tertiary feed pump station. The tertiary denitrifying fixed-film system was assumed to be at the northeast part of the plant site. Because it is separate from the mainstream process, the County could potentially purchase off-site property for the tertiary system. Therefore, it has the benefit of having the potential to leverage an offsite property acquisition to site the system, but provisions for routing secondary effluent to the tertiary system and for routing tertiary effluent back to the existing chlorine contact channels would still be required, along with routing of tertiary backwash waste to the existing primary treatment system. These interconnections between the new tertiary system and existing systems may mitigate benefits of locating the tertiary system offsite.

**Challenges and Potential Risks.** There may be some conveyance challenges for flow distribution between the new and existing aeration basins; a more active flow distribution scheme than the current setup may be required. With respect to constructability considerations, the new aeration basins and tertiary system can likely be constructed with minimal impacts to current plant operations. Constructing new aeration basins will require demolishing an existing storage building and relocating construction trailers. It is assumed that the existing north chlorine contact channel can be reconfigured to convey secondary effluent from the secondary clarifiers to the tertiary feed pump station, which involves reversing the direction of flow. A new chlorine contact channel would then need to be added alongside the existing channel conveying tertiary effluent to the existing south chlorine contact channel. The hydraulics would need to be confirmed during design.

A potential risk for this alternative is the construction of new facilities in the existing flood plain on the east side of the expansion area. This risk can be mitigated by constructing a flood control dike, which is accounted for in the cost estimates discussed in Section 4. There are also operational challenges in switching between MLE mode of operation for seasonal nitrogen removal starting in spring and A/O mode in the winter. There is potential for proliferation of filamentous organisms during the transition periods and a slow re-establishment of the PAO population when switching from MLE to A/O modes, which could negatively impact clarifier performance and effluent quality for BOD and TSS.

Table 6 summarizes the estimated GHG emissions for Alternative 2A.

Table 6. South Plant GHG Emissions for Alternative 2A	
Parameter	Value
GHG emissions (CO <sub>2</sub> e MT/yr)	
Nitrous oxide	11,600
Energy <sup>a</sup>	0
Chemicals	6,900
Total	18,500

a. Per information provided by King County, GHG emissions associated with power consumption are assumed to be zero for this analysis because South Plant is now purchasing 100 percent renewable energy from Puget Sound Energy.



### 3.2.2 Alternative 2B – MLE + Sidestream Anammox

In this alternative, the existing aeration basins will be configured for the MLE process. In addition, an anammox-based sidestream process would be added to reduce ammonia loading from the centrate that is routed to the secondary system. Figure 3 shows a process flow schematic for Alternative 2B.

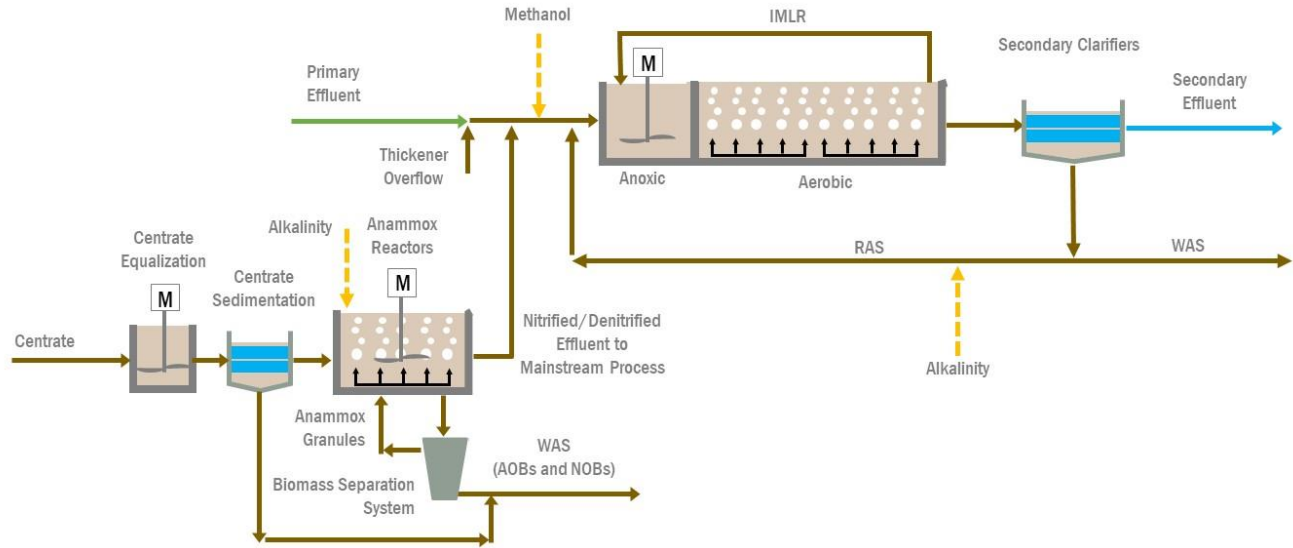

Figure 3. Process flow schematic for Alternative 2B – MLE + sidestream anammox

Table 7 summarizes the modeling results and sizing of major facilities and equipment for Alternative 2B.

Table 7. South Plant Nitrogen Removal Modeling Results and System Sizing for Alternative 2B	
Parameter	Value
Final effluent TIN, mg/L	
@ shoulder average wet weather flow and max month load	7.9
@ summer avg dry weather flow and load	7.8
@ winter avg wet weather flow and load	35
Overall TN removal, %	
@ shoulder average wet weather flow and max month load	83
@ summer avg dry weather flow and load	80
@ winter avg wet weather flow and load	27
Annual average	50
Annual average aeration requirements	
Aeration basin air flow, scfm	39,600
Annual average supplemental chemical requirements	
Alkalinity (25% caustic), gpd	2,980
Methanol, gpd	780
New aeration basins <sup>a</sup>	
Number of new basins	3
Volume per basin, MG	4.27



Table 7. South Plant Nitrogen Removal Modeling Results and System Sizing for Alternative 2B	
Parameter	Value
Sidestream treatment	
Type	Anammox
Centrate equalization tank volume, gal	110,000
Centrate sedimentation tank volume, gal	207,000
Number of reactor tanks	2
Volume of reactor tank, gal	500,000

a. A sidewater depth of 22 ft was assumed for the new aeration basins

A preliminary site layout for Alternative 2B is provided in Attachment A. Similar to Alternative 2A, the new aeration basins are assumed to have a SWD of 22 ft to reduce footprint.

**Challenges and Potential Risks.** Similar to Alternative 2A, there will be conveyance challenges for flow distribution between new and existing aeration basins. The new basins can likely be constructed with minimal impacts to current plant operations. An existing storage building and relocation of construction trailers will be required to construct the new basins. Similar to Alternative 2A, there are also operational challenges in switching between MLE mode of operation for nitrogen removal in the summer and A/O mode in the winter.

Table 8 summarizes the estimated GHG emissions for Alternative 2B.

Table 8. South Plant GHG Emissions for Alternative 2B	
Parameter	Value
GHG emissions (CO <sub>2</sub> e MT/yr)	
Nitrous oxide	11,900
Energy <sup>a</sup>	0
Chemicals	3,500
Total	15,400

a. Per information provided by King County, GHG emissions associated with power consumption are assumed to be zero for this analysis because South Plant is now purchasing 100 percent renewable energy from Puget Sound Energy.

### 3.3 Scenario 3 – Year-round Nitrogen Removal with Effluent TIN Limit of 8 mg/L Equivalent

For this scenario, South Plant would provide year-round nitrogen removal. An equivalent annual average effluent TIN limit of 8 mg/L was assumed. It is considered an equivalent limit, as the effluent TIN concentrations could be lower in the summer and higher in the winter, such that on an annual average basis, the plant achieves an effluent TIN concentration no higher than 8 mg/L. Two alternatives were evaluated for this scenario, as described below.

An additional alternative that retained the existing mainstream process but added tertiary nitrifying/denitrifying fixed-film systems (Alternative 3C) was also initially investigated but eliminated from further consideration after completing preliminary modeling and site layouts. While Alternative 3C would have avoided expansion of the existing aeration basins, the new tertiary systems would likely have required a similar footprint to new aeration basins for Alternatives 3A and 3B, while also requiring significantly higher chemical demands for supplemental alkalinity and methanol. Therefore, the County decided to eliminate Alternative 3C from this analysis and evaluate a tertiary nitrifying/denitrifying alternative as part of scenario 4, where tertiary treatment was shown to provide a greater footprint reduction compared to mainstream





activated sludge processes for nitrogen removal (without intensification) and fit better within the existing site footprint.

### 3.3.1 Alternative 3A – 4SMB + Sidestream Anammox

Alternative 3A is similar to Alternative 2B, but with a 4SMB instead of an MLE process. Figure 4 shows a process flow schematic for this alternative. The 4SMB process is an expansion of the MLE process, with addition of a second set of anoxic and aerobic zones. The mixed liquor (ML) leaving the first aerobic zone enters a second anoxic zone where the residual nitrate is further reduced. The second aerated zone serves as a polishing step to nitrify the ammonia formed in the second anoxic zone and to oxidize any residual carbon from the second anoxic zone. External carbon, such as methanol, is often required at the second anoxic zone to drive denitrification because readily biodegradable carbon has already been consumed upstream.

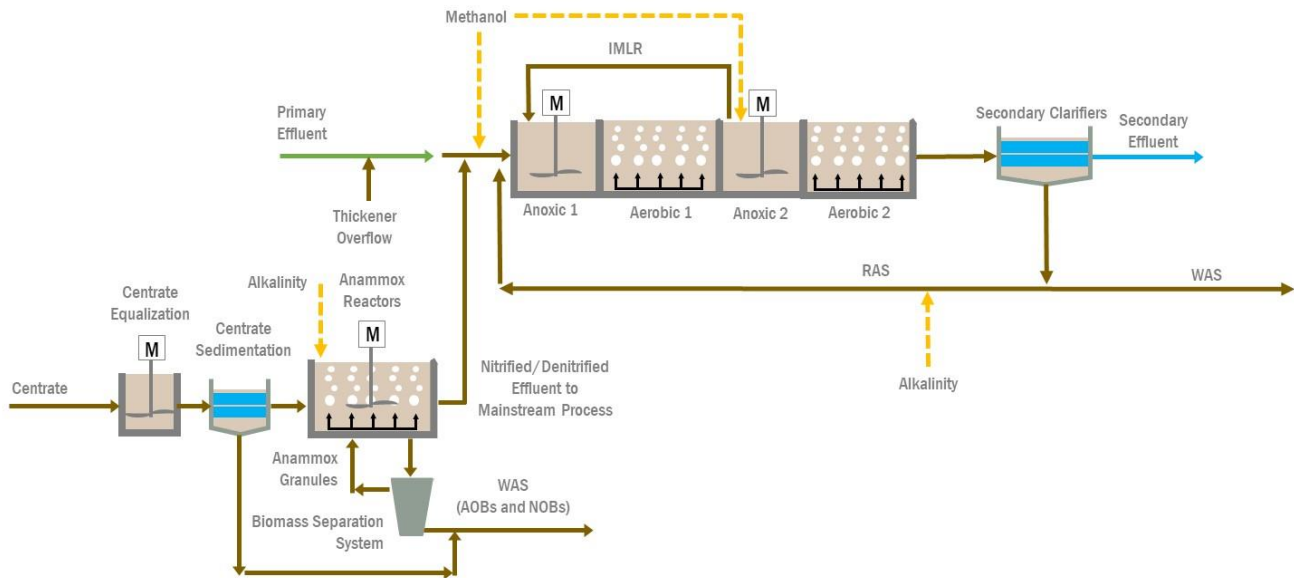

Figure 4. Process flow schematic for Alternative 3A – 4SMB + sidestream anammox

Table 9 summarizes the modeling results and sizing of major facilities and equipment for Alternative 3A.

Table 9. South Plant Nitrogen Removal Modeling Results and System Sizing for Alternative 3A	
Parameter	Value
Final effluent TIN, mg/L	
@ Winter max month flow and load	12
@ summer avg dry weather flow and load	2.9
@ winter avg wet weather flow and load	12
Annual average (load basis)	< 8
Overall TN removal, %	
@ Winter max month flow and load	70
@ summer avg dry weather flow and load	90
@ winter avg wet weather flow and load	72
Annual average	80
Annual average aeration requirements	
Aeration basin air flow, scfm	60,250

Table 9. South Plant Nitrogen Removal Modeling Results and System Sizing for Alternative 3A	
Parameter	Value
Annual average supplemental chemical requirements	
Alkalinity (25% caustic), gpd	4,940
Methanol, gpd	1,920
New aeration basins <sup>a</sup>	
Number of new basins	7
Volume per basin, MG	4.27
Sidestream treatment	
Type	Anammox
Centrate equalization tank volume, gal	110,000
Centrate sedimentation tank volume, gal	207,000
Number of reactor tanks	2
Volume of reactor tank, gal	500,000

a. A sidewater depth of 22 ft was assumed for the new aeration basins

A preliminary site layout for Alternative 3A is provided in Attachment A.

**Challenges and Potential Risks.** Site layout and implementation challenges for this alternative are similar to those for Alternative 2B. With the higher aeration basin requirements, this alternative has the risk of limiting available space for future aeration basin expansion.

Table 10 summarizes the estimated GHG emissions for Alternative 3A.

Table 10. South Plant GHG Emissions for Alternative 3A	
Parameter	Value
GHG emissions (CO <sub>2</sub> e MT/yr)	
Nitrous oxide	19,800
Energy <sup>a</sup>	0
Chemicals	6,200
Total	26,100

a. Per information provided by King County, GHG emissions associated with power consumption are assumed to be zero for this analysis because South Plant is now purchasing 100 percent renewable energy from Puget Sound Energy.

### 3.3.2 Alternative 3B – 4SMB + Sidestream Bioaugmentation

Alternative 3B is similar to Alternative 3A, except that bioaugmentation is used for the sidestream process instead of anammox. In bioaugmentation, the ammonia-rich centrate is combined with RAS in a sidestream aeration basin to achieve nitrification. Sending the nitrified effluent from this sidestream basin, which is enriched with nitrifying organisms, enhances the nitrification process in the mainstream aeration basins. For this evaluation, the bioaugmentation reaeration (BAR) configuration was assumed. Figure 5 shows a process flow schematic for this alternative.

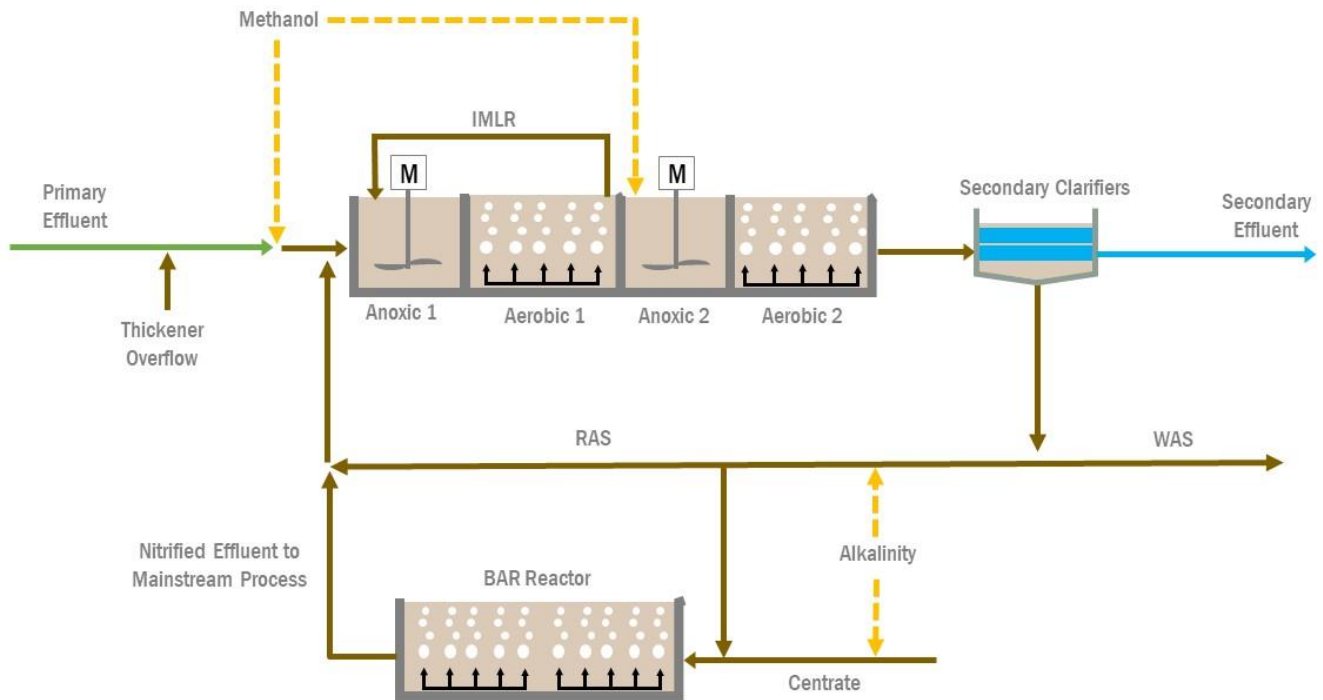

Figure 5. Process flow schematic for Alternative 3B – 4SMB + sidestream bioaugmentation

Table 11 summarizes the modeling results and sizing of major facilities and equipment for Alternative 3B.

Table 11. South Plant Nitrogen Removal Modeling Results and System Sizing for Alternative 3B	
Parameter	Value
Final effluent TIN, mg/L	
@ Winter max month flow and load	12
@ summer avg dry weather flow and load	2.8
@ winter avg wet weather flow and load	12
Annual average (load basis)	< 8
Overall TN removal, %	
@ Winter max month flow and load	70
@ summer avg dry weather flow and load	91
@ winter avg wet weather flow and load	72
Annual average	80
Annual average aeration requirements	
Aeration basin air flow, scfm <sup>a</sup>	66,650
Annual average supplemental chemical requirements	
Alkalinity (25% caustic), gpd	5,250
Methanol, gpd	4,190
New aeration basins <sup>b</sup>	
Number of new basins	6
Volume per basin, MG	4.27
Sidestream treatment	
Type	Bioaugmentation
No. of BAR reactor tanks	1
Volume of reactor tank, MG	2.5

a. Includes air flow requirements for aeration at the BAR reactor

b. A sidewater depth of 22 ft was assumed for the new aeration basins.

A preliminary site layout for Alternative 3B is provided in Attachment A. The BAR reactor tank is assumed to be located just north of the pod 6 secondary clarifiers.

**Challenges and Potential Risks.** This alternative has similar site layout and implementation challenges as Alternative 3A. In addition, it was assumed that the existing RAS pumps could be used to pump a portion of the RAS to the BAR reactor tank. This will need to be confirmed during detailed design. Similar to Alternative 3A, this alternative has the risk that there will be more limited available space for future aeration basin expansion.

Table 12 summarizes the estimated GHG emissions for Alternative 3B.

Table 12. South Plant GHG Emissions for Alternative 3B	
Parameter	Value
GHG emissions (CO <sub>2</sub> e MT/yr)	
Nitrous oxide	19,300
Energy <sup>a</sup>	0
Chemicals	8,200
Total	27,500

a. Per information provided by King County, GHG emissions associated with power consumption are assumed to be zero for this analysis because South Plant is now purchasing 100 percent renewable energy from Puget Sound Energy.



### 3.4 Scenario 4 – Year-round Nitrogen Removal with Effluent TIN of 3 mg/L

For this scenario, South Plant would provide year-round nitrogen removal to achieve an effluent TIN concentration of 3 mg/L. This scenario, which represents the typical limits of performance for the best available nitrogen removal technologies, could be a possible scenario for South Plant if a bubble permit is used (i.e., lower effluent TIN limits for South Plant in exchange for higher effluent TIN limits at West Point Treatment Plant or Brightwater Treatment Plant). Four alternatives were evaluated for this scenario, as described below.

An additional alternative using 4SMB with sidestream bioaugmentation (Alternative 4B) was also initially investigated but eliminated from further consideration after completing preliminary modeling and site layouts. Compared to Alternative 4A with sidestream anammox, sidestream bioaugmentation reduced the mainstream process volume/footprint by approximately 12 percent but would have had higher operating costs (higher methanol demands, aeration requirements, and WAS production). Like Alternative 4A, Alternative 4B would have been very difficult to fit on the existing site footprint. Sidestream bioaugmentation would also require complex tie-ins to the existing RAS system, whereas sidestream anammox could be implemented with minimal impacts to the mainstream process. Therefore, the County decided to eliminate Alternative 4B from this analysis.

Because preliminary modeling and site layouts showed footprint constraints for Alternatives for 4A and 4B, an intensification alternative was added to evaluate the 4SMB process in a MBR configuration (Alternative 4E), which reduces the volume/footprint required for new aeration basins and also replaces the solids separation step of the existing secondary clarifiers (allowing new facilities to be constructed in footprint occupied by the existing secondary clarifiers).

#### 3.4.1 Alternative 4A – 4SMB + Sidestream Anammox

Alternative 4A has the same configuration as Alternative 3A. Figure 6 shows a process flow schematic for this alternative.

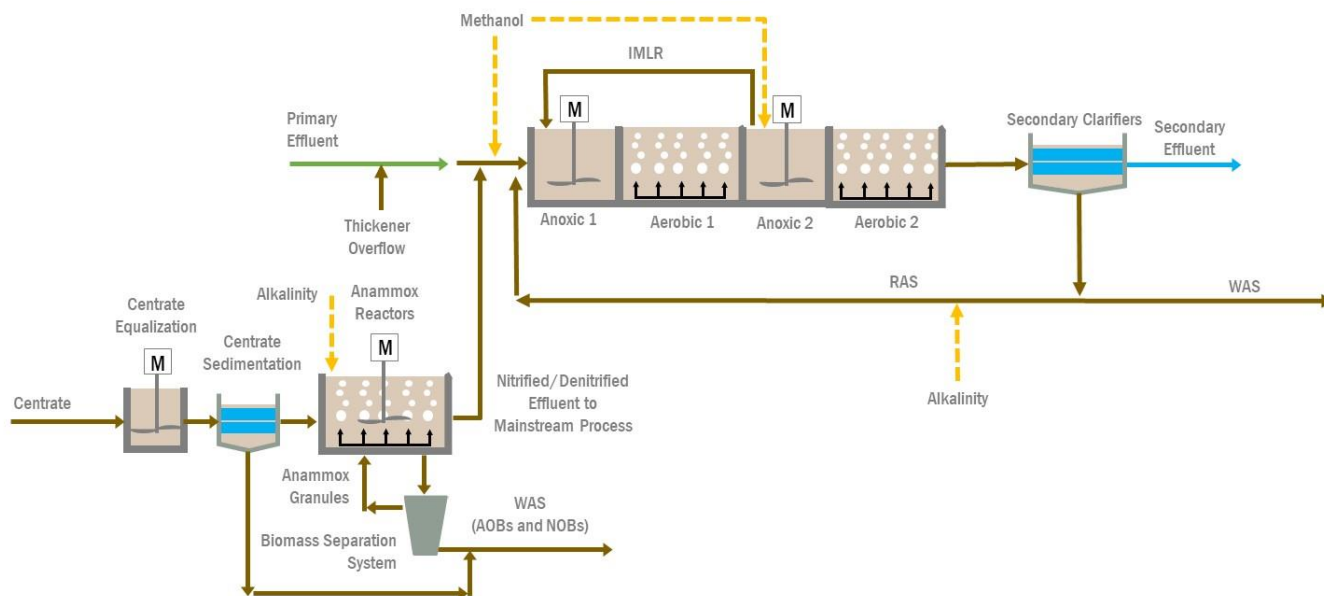

Figure 6. Process flow schematic for Alternative 4A – 4SMB + sidestream anammox

Table 13 summarizes the modeling results and sizing of major facilities and equipment for Alternative 4A.

<b>Table 13. South Plant Nitrogen Removal Modeling Results and System Sizing for Alternative 4A</b>	
<b>Parameter</b>	<b>Value</b>
Final effluent TIN, mg/L	
@ Winter max month flow and load	2.9
@ summer avg dry weather flow and load	2.9
@ winter avg wet weather flow and load	3.0
Overall TN removal, %	
@ Winter max month flow and load	90
@ summer avg dry weather flow and load	90
@ winter avg wet weather flow and load	90
Annual average	90
Annual average aeration requirements	
Aeration basin air flow, scfm	57,800
Annual average supplemental chemical requirements	
Alkalinity (25% caustic), gpd	1,440
Methanol, gpd	2,600
New aeration basins <sup>a</sup>	
Number of new basins	11
Volume per basin, MG <sup>b</sup>	4.28, 5.98
Sidestream treatment	
Type	Anammox
Centrate equalization tank volume, gal	110,000
Centrate sedimentation tank volume, gal	207,000
Number of reactor tanks	2
Volume of reactor tank, gal	500,000

a. A sidewater depth of 22 ft was assumed for the new aeration basins.

b. Preliminary layout was developed assuming 6 basins at 4.27 MG each and 5 basins at 5.98 MG each.

A preliminary site layout for Alternative 4A is provided in Attachment A. To accommodate the large aeration basin requirements, some of the new aeration basins are assumed to be constructed north of pods 5 and 6 secondary clarifiers and would have higher volume per basin than the other new aeration basins as shown on the site layout. All new basins are assumed to have a SWD of 22 feet, but deeper basins could potentially be considering during design to further reduce footprint.

**Challenges and Potential Risks.** This alternative has similar site layout and implementation challenges as Alternatives 3A. Potential risks include no available space for future aeration basin or secondary clarifier expansion, and construction of new facilities in the existing flood plain on the east side of the expansion area. The latter can be mitigated by constructing a flood control dike and is accounted for in the cost estimates discussed in Section 4.

Table 14 summarizes the estimated GHG emissions for Alternative 4A.

Table 14. South Plant GHG Emissions for Alternative 4A	
Parameter	Value
GHG emissions (CO <sub>2</sub> e MT/yr)	
Nitrous oxide	33,500
Energy <sup>a</sup>	0
Chemicals	3,300
Total	36,900

a. Per information provided by King County, GHG emissions associated with power consumption are assumed to be zero for this analysis because South Plant is now purchasing 100 percent renewable energy from Puget Sound Energy.

### 3.4.2 Alternative 4C – MLE + Tertiary Denitrifying Fixed-Film System

Alternative 4C has the same configuration as Alternative 2A. Figure 7 shows a process flow schematic for this alternative.

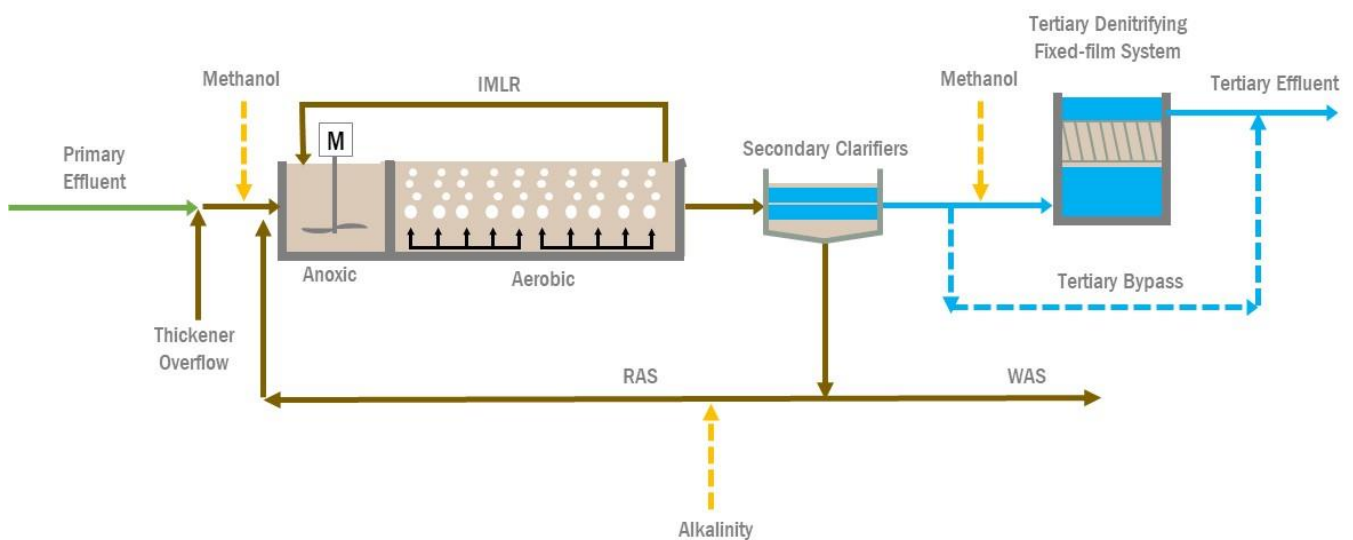

Figure 7. Process flow schematic for Alternative 4C – MLE + tertiary denitrifying fixed-film system

Table 15 summarizes the modeling results and sizing of major facilities and equipment for Alternative 4C.

Table 15. South Plant Nitrogen Removal Modeling Results and System Sizing for Alternative 4C	
Parameter	Value
Secondary effluent TIN, mg/L	
@ Winter max month flow and load	22
@ summer avg dry weather flow and load	17
@ winter avg wet weather flow and load	23
Final Effluent TIN, mg/L <sup>a</sup>	
@ Winter max month flow and load	3
@ summer avg dry weather flow and load	3
@ winter avg wet weather flow and load	3
Overall TN removal, % <sup>b</sup>	
@ Winter max month flow and load	89
@ summer avg dry weather flow and load	90
@ winter avg wet weather flow and load	90
Annual average	90
Annual average aeration requirements	
Aeration basin air flow, scfm	66,300
Annual average supplemental chemical requirements	
Alkalinity (25% caustic), gpd	15,000
Methanol, gpd	6,000
New aeration basins <sup>c</sup>	
Number of new basins	6
Volume per basin, MG	4.27
Tertiary fixed-film system	
Number of denitrifying cells	18
Total cell volume, MG	3.41

- a. Final effluent concentrations including removals across the tertiary process.
- b. Overall removal accounts for removals across tertiary treatment.
- c. A sidewater depth of 22 ft was assumed for the new aeration basins.

A preliminary site layout for Alternative 4C is provided in Attachment A. The layout is similar to that for Alternative 2A, but with more of the available site space taken up for new aeration basins and tertiary filter cells. The tertiary denitrifying fixed-film system was assumed to be at the northeast part of the plant site. Because it is separate from the mainstream process, the County could potentially purchase off-site property for the tertiary system. Therefore, it has the benefit of having the potential to leverage an offsite property acquisition to site the system, but provisions for routing secondary effluent to the tertiary system and for routing tertiary effluent back to the existing chlorine contact channels would still be required, along with routing of tertiary backwash waste to the existing primary treatment system. These interconnections between the new tertiary system and existing systems may mitigate benefits of locating the tertiary system offsite.

**Challenges and Potential Risks.** This alternative will also have the same conveyance and implementation challenges as Alternative 2A. Potential risks include no available space for future aeration basin expansion and construction of new facilities in the existing flood plain on the east side of the expansion area.

Table 16 summarizes the estimated GHG emissions for Alternative 4C.

Table 16. South Plant GHG Emissions for Alternative 4C	
Parameter	Value





Table 16. South Plant GHG Emissions for Alternative 4C	
Parameter	Value
GHG emissions (CO <sub>2</sub> e MT/yr)	
Nitrous oxide	10,600
Energy <sup>a</sup>	0
Chemicals	19,100
Total	29,700

a. Per information provided by King County, GHG emissions associated with power consumption are assumed to be zero for this analysis because South Plant is now purchasing 100 percent renewable energy from Puget Sound Energy.

### 3.4.3 Alternative 4D – Existing Mainstream + Tertiary Nitrifying/Denitrifying Fixed-Film System

In Alternative 4D, the existing activated sludge process would remain, with addition of a tertiary nitrifying/denitrifying fixed-film system to provide the targeted nitrogen removal. The tertiary nitrifying/denitrifying system consists of two stages of filter cells. Similar to Alternative 2A, a BAF-type system is assumed for this analysis. A tertiary feed pump station would be added to pump secondary effluent to the tertiary system. The first stage would be an upflow filter for nitrification, with process air added to keep the filter bed aerobic. Effluent from the nitrifying filters would then flow by gravity through the second stage denitrifying filters. Supplemental alkalinity would be added at the first stage nitrifying filters, and supplemental carbon in the form of methanol would be added between the two stages to drive denitrification. Figure 8 shows a process flow schematic for this alternative.

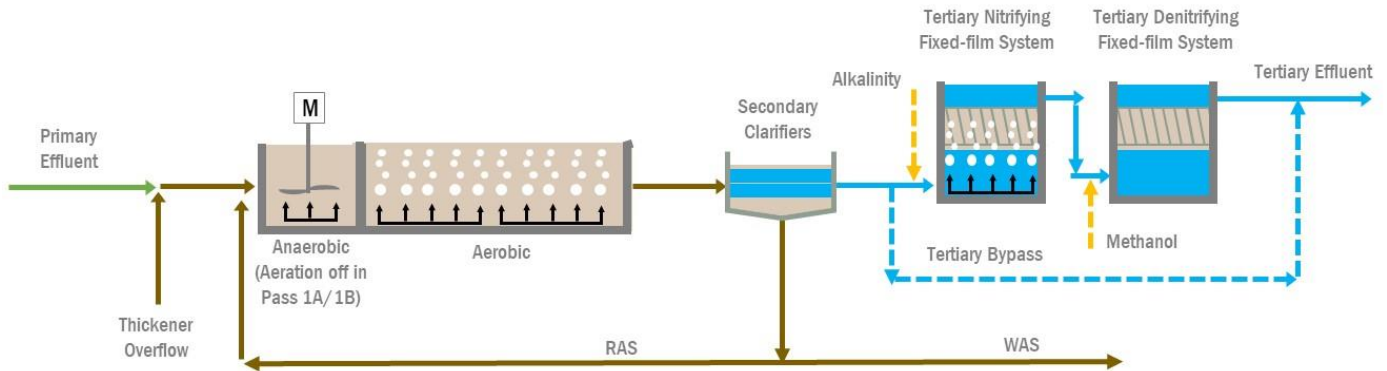

Figure 8. Process flow schematic for Alternative 4D – existing mainstream + tertiary nitrifying/denitrifying fixed-film system

Table 17 summarizes the modeling results and sizing of major facilities and equipment for Alternative 4D.

Table 17. South Plant Nitrogen Removal Modeling Results and System Sizing for Alternative 4D	
Parameter	Value
Secondary effluent TIN, mg/L	
@ Winter max month flow and load	38
@ summer avg dry weather flow and load	21
@ winter avg wet weather flow and load	23
Final effluent TIN, mg/L <sup>a</sup>	
@ Winter max month flow and load	3
@ summer avg dry weather flow and load	3
@ winter avg wet weather flow and load	3
Overall TN removal, % <sup>b</sup>	

Table 17. South Plant Nitrogen Removal Modeling Results and System Sizing for Alternative 4D	
Parameter	Value
@ Winter max month flow and load	90
@ summer avg dry weather flow and load	91
@ winter avg wet weather flow and load	91
Annual average	91
Annual average aeration requirements	
Aeration basin air flow, scfm	50,350
Annual average supplemental chemical requirements	
Alkalinity (25% caustic), gpd	17,750
Methanol, gpd	9,700
New aeration basins	
Number of new basins	0
Tertiary fixed-film system	
Number of nitrifying cells	30
Total nitrifying cell volume, MG	6.65
Number of denitrifying cells	24
Total denitrifying cell volume, MG	4.54

a. Final effluent concentrations including removals across the tertiary process.

b. Overall removal accounts for removals across tertiary treatment.

A preliminary site layout for Alternative 4D is provided in Attachment A. Similar to Alternative 4C, the County could potentially purchase off-site property for the tertiary system, but interconnections between the new tertiary systems and existing systems may mitigate benefits of locating tertiary offsite.

**Challenges and Potential Risks.** For this alternative, new aeration basins would not be required. The tertiary system, however, would take up a large portion of the available space north of the existing aeration basins and secondary clarifiers. Construction of the new tertiary system can likely be completed with minimal impacts to current plant operations but would require demolishing an existing storage building and relocating several construction trailers. This alternative would have the same challenge as Alternatives 2A and 4C in terms of conveying the secondary effluent to the tertiary system in the existing chlorine contact channel and the tertiary effluent back to the chlorine contact channel. Potential risks for this alternative include limited available space for future aeration basins and secondary clarifier expansion, along with construction of new facilities in the existing flood plain on the east side of the expansion area. The latter can be mitigated by construction of a flood control dike and is accounted for in the cost estimates discussed in Section 4.

Table 18 summarizes the estimated GHG emissions for Alternative 4D.

Table 18. South Plant GHG Emissions for Alternative 4D	
Parameter	Value
GHG emissions (CO <sub>2</sub> e MT/yr)	
Nitrous oxide	15,600
Energy <sup>a</sup>	0
Chemicals	24,500
Total	40,100

a. Per information provided by King County, GHG emissions associated with power consumption are assumed to be zero for this analysis because South Plant is now purchasing 100 percent renewable energy from Puget Sound Energy.



### 3.4.4 Alternative 4E – 4SMB/MBR + Sidestream Anammox

In Alternative 4E, the existing conventional activated sludge system would be converted to an MBR system, with a 4SMB configuration in the aeration basins. Figure 9 shows a process flow schematic for this alternative. When configured as a 4SMB/MBR process, the ML from the aeration basins is sent to the membrane basins instead of clarifiers for solids separation. MBR treatment requires fine screening to protect the membranes from debris; therefore, new primary effluent fine screens would be added as part of this alternative. In addition to conversion to MBR treatment, a new sidestream anammox system is included in this alternative.

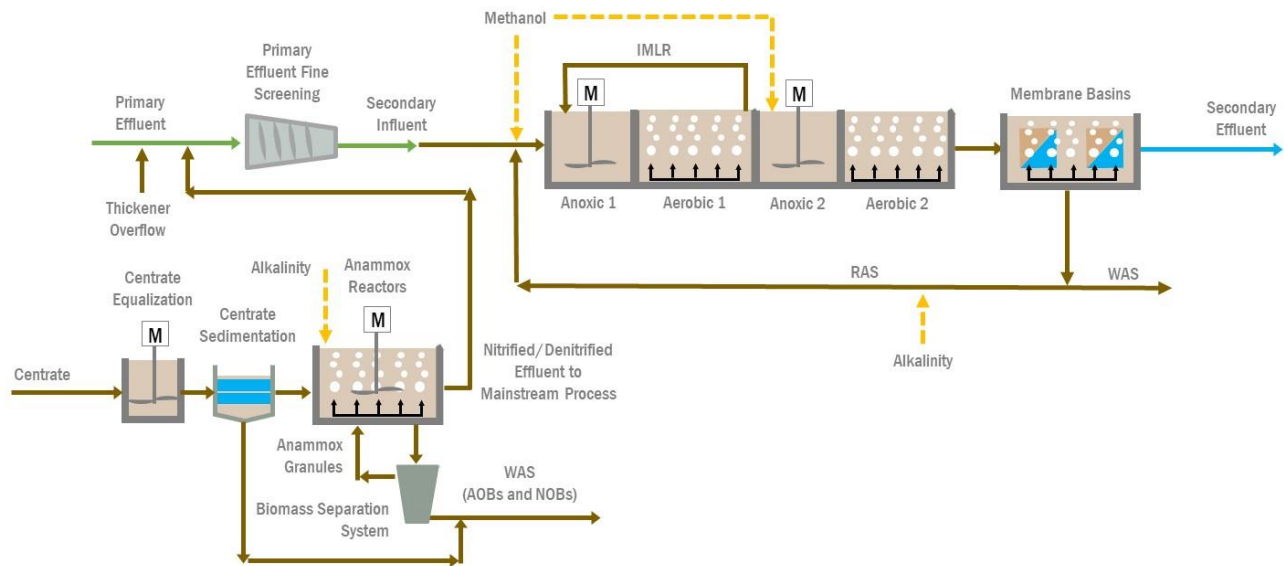

Figure 9. Process flow schematic for Alternative 4E – 4SMB/MBR + sidestream anammox

Table 19 summarizes the modeling results and sizing of major facilities and equipment for Alternative 4E.

Table 19. South Plant Nitrogen Removal Modeling Results and System Sizing for Alternative 4E	
Parameter	Value
Final effluent TIN, mg/L	
@ Winter max month flow and load	2.9
@ summer avg dry weather flow and load	2.8
@ winter avg wet weather flow and load	2.9
Overall TN removal, %	
@ Winter max month flow and load	90
@ summer avg dry weather flow and load	91
@ winter avg wet weather flow and load	91
Annual average	91
Annual average aeration requirements	
Aeration basin air flow, scfm	55,000
Membrane scouring air flow, scfm	144,100
Annual average supplemental chemical requirements	
Alkalinity (25% caustic), gpd	1,440
Methanol, gpd	6,470

Table 19. South Plant Nitrogen Removal Modeling Results and System Sizing for Alternative 4E	
Parameter	Value
<b>New aeration basins <sup>a</sup></b>	
Number of new basins	3
Volume per basin, MG	4.27
<b>New membrane basins</b>	
Peak hydraulic capacity (at 10 gfd flux limit)	287
Number of new basins	54
Volume per basin, MG	0.20
<b>Sidestream treatment</b>	
Type	Anammox
Centrate equalization tank volume, gal	110,000
Centrate sedimentation tank volume, gal	207,000
Number of reactor tanks	2
Volume of reactor tank, gal	500,000

a. A sidewater depth of 22 ft was assumed for the new aeration basins.

A preliminary site layout for Alternative 4E is provided in Attachment A. The new membrane basins are assumed to be constructed on the east side of the plant site. At least one pod of secondary clarifiers would need to be demolished to make space for the membrane basins and RAS piping. It was assumed that ML from the aeration basins would be pumped to the membrane basins, thus requiring an additional membrane feed pump station. RAS then flows by gravity from the membrane basins back to the aeration basins. The site layout shows that pods 1 to 4 secondary clarifiers would remain, but these clarifiers would not be used. Some of the clarifiers could be converted into equalization tanks to reduce peak flows to the MBRs, which would reduce membrane requirements. This would require additional pumping from the equalization tanks to the MBR system.

**Challenges and Potential Risks.** This alternative will have significant conveyance challenges associated with the primary effluent, ML, and RAS streams. At a typical recycle rate of four times the secondary influent flow (4Q) for an MBR system, the mixed liquor flow at five times (5Q) and the RAS flow (at 4Q) would be very high. For this analysis, it was assumed that the existing ML and RAS channels can be used for conveyance to and from the membrane basins. The hydraulic capacity of these channels would need to be verified during design. RAS from the membrane basins would likely need to be conveyed in above-grade conduits.

Potential risks for this alternative include insufficient existing power supply for the increased electrical loads, lower-than-expected membrane permeability that would limit secondary treatment capacity, high operational complexity, and construction of new facilities in the existing flood plain on the east side of the expansion area. These risks were accounted for in the cost estimates and overall analysis of planning alternatives discussed in Section 5.

Table 20 summarizes the estimated GHG emissions for Alternative 4E.



Parameter	Value
GHG emissions (CO <sub>2</sub> e MT/yr)	
Nitrous oxide	33,400
Energy <sup>a</sup>	0
Chemicals	7,300
Total	40,800

a. *Per information provided by King County, GHG emissions associated with power consumption are assumed to be zero for this analysis because South Plant is now purchasing 100 percent renewable energy from Puget Sound Energy. However, if electricity use increases significantly from current usage, the County may not be able to purchase all-renewable electricity or may need to pay an additional premium for the additional all-renewable electricity. This would increase either the GHG emissions or the operating costs. Because of the significantly higher energy demand for Alternative 4E compared to the other alternative, there is a high risk for either notable GHG emissions associated with energy or higher energy costs.*

### 3.5 Supplemental Carbon Addition Discussion

For many of the scenarios modeled, additional carbon would be required to allow for more complete denitrification and achieve lower effluent TIN concentrations than are possible with the existing influent wastewater’s readily degradable BOD. For this planning-level study, the carbon supplementation was assumed as a methanol addition system because of the low capital cost and to simplify the biological process modeling. Methanol also has the benefit of being a specific carbon source for methanol using denitrifying bacteria, which minimizes additional sludge generation in the system; however, methanol-using bacteria take time to grow, meaning there is an acclimation period that often ranges from 2 to 6 weeks (or more) to grow the organisms to perform denitrification. Methanol addition also has a high operational cost and GHG emissions through continued purchase of the chemical. It may be possible to offset or eliminate this chemical use by constructing and operating primary sludge fermenters at this facility for some scenarios. For these reasons, it may be advantageous to explore alternate carbon sources to methanol.

One possible alternate carbon source would be primary sludge fermentation. Primary sludge fermentation takes primary sludge captured in the primary clarifiers and ferments it to readily degradable volatile fatty acids (VFA) that can be used as the readily degradable carbon source for driving denitrification. Primary sludge fermentation sizing and the amount of VFAs generated is dependent on the amount of supplemental carbon required (i.e., how much primary sludge needs to be fermented), if the tanks are heated or not, and if the primary sludge is pre-thickened or not. In addition to VFAs, primary sludge fermentate also contains nutrients like soluble phosphorus and TKN that are also released from the solids as part of the fermentation process. VFAs are also a non-specific carbon source for bacteria in the system, meaning there is substantial competition for the VFAs and generation of additional biomass that aren’t all denitrifying bacteria. This means the amount of fermentate that must be added is often much greater than the stoichiometric amount required for removing nitrogen in the primary effluent alone, as the demand of the additional nutrients in the fermentate as well as competition for the VFAs from non-denitrifying bacteria must be accounted for. It is not uncommon to ferment all the primary sludge to account for these additional demands. This also results in substantially more biomass generation and, therefore, a higher MLSS concentration and waste sludge mass than a system operated on methanol. Primary sludge fermentate also cannot be used in tertiary applications because it is not a “clean” enough carbon source and would lead to ammonia breakthrough and overgrowth of other undesirable organisms in the tertiary denitrifying systems.

BC roughly sized two fermentation systems to see how large the system may be for South Plant. One system uses the current dilute primary sludge pumped from the primary clarifiers with post-fermentation dedicated primary sludge thickening for fermentate separation. The second system assumes thickening the primary sludge in the clarifiers to 3 percent solids, fermenting the pre-thickened primary sludge, then adding elutriation water to separate the fermentate from the solids before dedicated fermented primary sludge



thickening. In both options, the fermented primary sludge thickeners would be sized approximately equal, with the differences being the required size of the fermenter and addition of elutriation water. Both systems were sized for a 3-day hydraulic residence time (HRT) in the fermentation tank (at maximum month flow and load), assuming the tanks are unheated. Subsections 3.5.1 and 3.5.2 present a breakdown of sizing and assumptions.

It is important to note that a detailed investigation into the exact quantity of primary sludge fermentation required was not completed for this analysis. The information provided below on sizing is preliminary, for informational purposes only, and not intended for use in planning. Similarly, a cost opinion of the fermenters and primary sludge thickening facilities was not completed as part of this analysis. It is recommended that during any facility planning effort that a detailed investigation into primary sludge fermentation feasibility be completed before moving forward with design of any facility for supplemental carbon addition.

### **3.5.1 Unthickened Primary Sludge Fermenter**

For the current unthickened primary sludge, it is assumed there is 2.42 mgd of primary sludge flow at 0.7 percent solids at the maximum month primary sludge flow rate. Sizing a fermentation tank for this flow rate and a 3-day HRT requires 7.3 MG of tank volume. This is significantly larger than the current available DAFTs, so dedicated tanks would be needed. If dedicated fermentation tanks are constructed with 25-foot-deep SWD, three 130-foot-diameter tanks would be required. These are very large tanks and would consume considerable facility footprint.

Fermented primary sludge thickening facilities would have to be sized for at least 2.42 mgd flow capacity, and likely higher to handle peak week or even peak day loadings.

### **3.5.2 Pre-Thickened Primary Sludge Fermenter**

Assuming the existing primary clarifiers and primary sludge pumps could be operated to thicken primary sludge in the tanks to 3 percent solids, the flow of primary sludge would be 0.565 mgd. Sizing a fermentation system at this flow rate for a 3-day HRT requires 1.7 MG of tank volume. This is still larger than the existing DAFT tank volume available, so dedicated tanks would be needed. If dedicated fermentation tanks for this system are 25 ft SWD, then two 75-foot-diameter tanks would be required. It would be recommended that dedicated fermented primary sludge thickening facilities be sized to handle 2.0 mgd of flow volume, assuming roughly 3 times the maximum month primary sludge flow is added as elutriation water to efficiently extract the VFAs needed for the system.

## **3.6 Hydraulic Risks Discussion**

Several of the alternatives have hydraulic risks/conveyance challenges that would need to be evaluated during facility planning and detailed design. The purpose of this section is to convey the scale of the challenges, but detailed evaluation is outside the scope of this study. Key hydraulic risks/challenges identified as part of this study include:

- Distribution of primary effluent and RAS between new and existing aeration basins.
  - Applies to all alternatives that require new aeration basins.
  - Layouts and cost estimating assume a passive flow split between new and existing aeration basins.
  - New active flow splitting, such as primary effluent or RAS pump stations, may be required to control the flow split between new and existing basins, especially for alternatives with a significantly larger volume of new aeration basins (e.g., Alternative 4A).
  - Alternative 4E (MBR) does include a new primary effluent pump station, which is assumed to be constructed adjacent to a new primary effluent fine screening facility. In addition, Alternative 4E includes a ML pump station with gravity flow of RAS to the aeration basins but assumes that the



existing ML and RAS channels can be repurposed for conveyance. If the hydraulic capacity of these channels is insufficient, significant modifications could be required to make this alternative hydraulically feasible.

- Conveyance of secondary effluent to a new tertiary feed pump station.
  - Applies to alternatives with new tertiary nitrifying and/or denitrifying processes.
  - Layouts and cost estimating assume the existing north chlorine contact channel can be reconfigured to convey secondary effluent from the secondary clarifiers to the tertiary feed pump station (reversing current flow direction starting from the effluent of the pod 1 secondary clarifiers), while also adding new chlorine contact channel conveying tertiary effluent to the existing south chlorine contact channel.
  - Feasibility of reversing the flow direction in the existing north chlorine contact channel would need to be confirmed.
  - New hypochlorite storage/dosing facilities may be required for chlorine injection into the new contact channel. Chlorine contact times would also need to be verified.
- Conveyance of RAS to new BAR reactor tank.
  - Applies to alternatives with new sidestream bioaugmentation (only Alternative 3B).
  - Layouts and cost estimating assume that up to 50 percent of the total RAS flow could be pumped to a new BAR reactor tank using the existing RAS pumps by adding new piping/valving into existing RAS headers in the RAS gallery, with new piping routed through the existing secondary north-south tunnel to the BAR reactor. In addition, BAR effluent is assumed to be conveyed by gravity from the BAR reactor to the existing RAS channel.
  - It is possible that additional modifications or an alternative approach would be required for RAS distribution for sidestream bioaugmentation.

## Section 4: Cost Analysis

Cost analysis included developing capital, operations and maintenance (O&M), and life-cycle costs. This section discusses the assumptions and results of the cost analysis for each alternative.

### 4.1 Capital Costs

Capital costs were developed as pre-Class 5 conceptual cost estimates to provide order-of-magnitude costs. In accordance with WTD estimating guidelines and direction, long-range planning estimated capital project costs developed prior to the more immediate near-term timeline of a class 5 estimate have an anticipated range of -50 percent to +300 percent (or greater) relative accuracy. As part of the WTD estimate development process, various allowances, including allowances for indeterminates (undefined requirements), construction change orders, and project contingencies were included based on Class 5 cost estimating guidelines. Each estimate provides similar documentation to that of the Association for the Advancement of Cost Engineering international Guidelines and Recommended Practice for a Class 5 estimate and is further supported by recommended practices of WTD planning-level cost estimates.

A total project cost developed for each alternative includes raw construction costs, contractor markups, change order allowance, sales tax, design and construction consulting fees, permitting, WTD staffing, contingency, and other indirect costs. Detailed descriptions of the basis and assumptions used in developing the project cost for each alternative are provided in the Basis of Estimates (BOE) documents in Attachment C.

### 4.1.1 Site-Specific Capital Cost Assumptions

Besides general cost estimating assumptions given in the BOE, a number of plant-specific and alternative-specific assumptions were also used. These include:

- A flood plain map provided by WTD indicates that the east side of the expansion area is within the flood plain; therefore, the alternatives that include constructing new facilities in that area (i.e., 2A, 4A, 4C, 4D, and 4E) include costs for constructing a flood control dike..
- Because of the large increase in energy demand to provide year-round nitrogen removal, an allowance for upgrading the plant electrical system is included for some of the alternatives. An allowance of \$2 million is included for scenario 3 and 4 alternatives (except for alternative 4E); an allowance of \$3 million is included for Alternative 4E, which has more than five times the estimated energy demand for secondary treatment than Alternative 1A. No electrical upgrade was assumed for alternatives 1A, 2A, and 2B.
- For all alternatives except Alternative 1A and 4D, it was assumed that three to five aeration blowers will be added to increase aeration capacity. The air flow capacity of each blower will be similar to the existing single-stage turbo blowers at South Plant. The number of blowers may be increased or decreased to optimize the performance and layout. Blower sizing should be further evaluated during design.
- No new odor control facilities were assumed to be added as part of the upgrades for each alternative. While evaluation of odor control requirements is outside the scope of this study, new odor control facilities would likely be needed for Alternative 4E as the aeration basins and membrane basins would be covered.
- Costs for any stormwater mitigation are not included because assessment of stormwater treatment systems is outside the scope of this study, but these systems would likely require expansion or modification as the plant is upgraded for nitrogen removal.
- Costs for solids system upgrades were not included. For Alternative 4E, upgrades to the thickening system may be required to process the screenings from the primary effluent fine screens. For Alternatives 2A, 4C and 4D, tertiary backwash waste is assumed to be routed to the primary clarifiers and then become part of the primary sludge, which would increase loadings to the solids treatment processes. Backwash waste solids projections are provided in Section 5.2. Based on the results of the flows and loads project capacity analysis, the digester capacity limit was predicted to be reached in the 2030s. The need for digester system upgrades would thus occur sooner for these alternatives. Impacts of increased solids loads from tertiary nitrogen removal facilities should be further evaluated during design.
- Complexity factors serve as adjustments to the WTD allied/indirect costs. The factors range from low, to routine, moderate, and high. For South Plant, routine or moderate complexity factors were assumed, except for Alternative 4E. For that alternative, because of the anticipated construction challenges associated with the conversion to MBR treatment, high complexity factors were assumed for some of the indirect cost categories.

### 4.1.2 Summary of Capital Costs

Table 21 summarizes the capital costs for the alternatives.





**Table 21. Summary of Capital Costs for South Plant Alternatives <sup>a</sup>**

Alternatives	Estimated probable cost of construction bid	Other construction cost	Total direct construction cost	Total indirect non-construction cost	Total project cost	Total project cost range	
						Low (-50 percent)	High (+300 percent)
Alt 1A: Existing mainstream + sidestream anammox	\$38,820,000	\$8,280,000	\$47,100,000	\$40,510,000	<b>\$87,610,000</b>	\$43,810,000	\$350,440,000
Alt 2A: MLE + tertiary denitrifying fixed-film	\$286,270,000	\$61,060,000	\$347,330,000	\$280,340,000	<b>\$627,660,000</b>	\$313,830,000	\$2,510,640,000
Alt 2B: MLE + sidestream anammox	\$209,090,000	\$44,600,000	\$253,690,000	\$210,160,000	<b>\$463,860,000</b>	\$231,930,000	\$1,855,440,000
Alt 3A: 4SMB + sidestream anammox	\$325,160,000	\$69,350,000	\$394,510,000	\$316,840,000	<b>\$711,350,000</b>	\$355,680,000	\$2,845,400,000
Alt 3B: 4SMB + sidestream bioaugmentation	\$278,580,000	\$59,420,000	\$338,000,000	\$274,910,000	<b>\$612,910,000</b>	\$306,460,000	\$2,451,640,000
Alt 4A: 4SMB + sidestream anammox	\$471,330,000	\$100,540,000	\$571,870,000	\$452,710,000	<b>\$1,024,570,000</b>	\$512,290,000	\$4,098,280,000
Alt 4C: MLE + tertiary denitrifying fixed-film	\$476,660,000	\$101,670,000	\$578,330,000	\$457,430,000	<b>\$1,035,750,000</b>	\$517,880,000	\$4,143,000,000
Alt 4D: Existing mainstream + tertiary nitrifying/denitrifying fixed-film	\$521,180,000	\$111,170,000	\$632,350,000	\$496,760,000	<b>\$1,129,110,000</b>	\$564,560,000	\$4,516,440,000
Alt 4E: 4SMB/MBR + sidestream anammox	\$902,980,000	\$192,610,000	\$1,095,590,000	\$941,870,000	<b>\$2,037,460,000</b>	\$1,018,730,000	\$8,149,840,000

a. Unescalated, undiscounted costs in 2020 dollars.



## 4.2 O&M Costs

O&M costs consist of power, chemical, and labor costs. Other O&M costs, including material and equipment replacement and other maintenance costs, are assumed to be insignificant compared to power, chemical, and additional labor costs, or the differences for those costs among alternatives are expected to be insignificant. Only O&M costs associated with primary effluent fine screening (if added), secondary system, tertiary nitrifying/denitrifying fixed-film system, and sidestream processes are included in this cost analysis. Electrical costs for motorized equipment were calculated from motor horsepower data provided by equipment vendors or estimated from process modeling results. Labor costs were calculated from the additional full-time equivalents (FTEs) estimated for the liquid-stream upgrades determined for each alternative.

### 4.2.1 Site-Specific O&M Cost Assumptions

Plant-specific and alternative-specific O&M cost assumptions include:

- Electrical costs were calculated from a blended rate provided by WTD for South Plant. Blended rate accounts for both costs based on a unit rate (dollar per kilowatt-hour [\$/kWh]) and demand charges. The blended rate calculated from 6 months of data in 2019 was \$0.0707/kWh, plus \$0.0051/kWh for the Green Direct Program. A combined rate of \$0.0758 was thus assumed.
- Alkalinity control is provided by adding 25 percent caustic solution. Unit cost for the caustic solution was based on data provided by WTD for Brightwater at \$0.067 per pound or \$0.72 per gallon. A unit cost of \$0.75 per gallon was assumed to account for some potential price variability. Including a 10.1 percent sales tax, a unit cost of \$0.83 per gallon was used.
- Methanol cost is \$2.42 per gallon based on a budgetary unit cost of \$2.20 per gallon provided by Cascade Columbia and 10.1 percent sales tax.
- Costs for sodium hypochlorite and citric acid were included for Alternative 4E as they are added for membrane cleaning. Annual average consumption rates of each chemical were provided by the MBR supplier (Suez). Unit costs of \$0.95 per gallon and \$13.66 per gallon were assumed for 12.5 percent sodium hypochlorite solution and 50 percent citric acid solution, respectively, both based on data provided by WTD for existing Brightwater operation and including 10.1 percent sales tax.
- Labor costs for additional FTEs were estimated based on an annual cost of \$204,000 per FTE provided by WTD, which includes salary and overhead costs.

### 4.2.2 Summary of O&M Costs

Table 22 summarizes the O&M costs for the alternatives.



**Table 22. Summary of Annual O&M Costs for South Plant Alternatives <sup>a</sup>**

Alternatives	Annual electricity cost	Annual chemical cost	Annual additional FTE cost	Total Annual O&M costs
Alt 1A: Existing mainstream + sidestream anammox	\$1,428,000	\$139,000	\$102,000	\$1,669,000
Alt 2A: MLE + tertiary denitrifying fixed-film	\$1,951,000	\$3,090,000	\$408,000	\$5,449,000
Alt 2B: MLE + sidestream anammox	\$1,582,000	\$1,584,000	\$306,000	\$3,472,000
Alt 3A: 4SMB + sidestream anammox	\$2,436,000	\$3,189,000	\$408,000	\$6,033,000
Alt 3B: 4SMB + sidestream bioaugmentation	\$2,521,000	\$5,290,000	\$408,000	\$8,219,000
Alt 4A: 4SMB + sidestream anammox	\$2,645,000	\$2,728,000	\$510,000	\$5,883,000
Alt 4C: MLE + tertiary denitrifying fixed-film	\$2,983,000	\$9,826,000	\$510,000	\$13,319,000
Alt 4D: Existing mainstream + tertiary nitrifying/denitrifying fixed-film	\$2,738,000	\$13,926,000	\$612,000	\$17,276,000
Alt 4E: 4SMB/MBR + sidestream anammox	\$7,880,000	\$7,074,000	\$918,000	\$15,872,000

a. Unescalated, undiscounted costs in 2020 dollars. Only electrical, chemical, and additional FTE costs for primary effluent fine screening (if added), secondary system, and sidestream processes are included.

### 4.3 Life–Cycle Costs

LCCA was performed to estimate the total net present value (NPV) of the capital and O&M costs over a 20-year life-cycle period. The following assumptions were used in the LCCA:

- Capital costs were assumed to be distributed over a 5-year period starting in 2030, representing a cashflow from design to construction completion as follows:
  - 5 percent in year 1
  - 10 percent in year 2
  - 25 percent in year 3
  - 40 percent in year 4
  - 20 percent in year 5
- O&M costs were included for the 20-year period from 2035 to 2054.
- Capital and O&M costs were escalated from the 2020 costs to the design year using an escalation rate of 3 percent.
- The escalated costs were then discounted back to the NPV in 2020 dollars using a discount rate of 5.25 percent.

Table 23 summarizes the life-cycle costs for the alternatives, as well as the total nitrogen load removed over the 20-year life-cycle period and the cost per pound of nitrogen removed.

**Table 23. Summary of Life-Cycle Costs for South Plant Alternatives**

Alternatives	Capital costs <sup>a</sup>	O&M costs <sup>a</sup>	NPV	TN removed (lb) <sup>b</sup>	Cost per lb N removed <sup>c</sup>
Alt 1A: Existing mainstream + sidestream anammox	\$87,610,000	\$33,370,000	(\$86,550,000)	102,809,900	\$0.84
Alt 2A: MLE + tertiary denitrifying fixed-film	\$627,660,000	\$108,980,000	(\$542,870,000)	111,483,400	\$4.87
Alt 2B: MLE + sidestream anammox	\$463,860,000	\$69,450,000	(\$394,610,000)	129,119,300	\$3.06
Alt 3A: 4SMB + sidestream anammox	\$711,350,000	\$120,660,000	(\$613,560,000)	208,373,700	\$2.94
Alt 3B: 4SMB + sidestream bioaugmentation	\$612,910,000	\$164,390,000	(\$564,510,000)	209,129,400	\$2.70
Alt 4A: 4SMB + sidestream anammox	\$1,024,570,000	\$117,660,000	(\$850,400,000)	235,470,900	\$3.61
Alt 4C: MLE + tertiary denitrifying fixed-film	\$1,035,750,000	\$266,380,000	(\$947,190,000)	234,566,800	\$4.04
Alt 4D: Existing mainstream + tertiary nitrifying/denitrifying fixed-film	\$1,129,110,000	\$345,510,000	(\$1,065,270,000)	237,016,200	\$4.49
Alt 4E: 4SMB/MBR + sidestream anammox	\$2,037,460,000	\$317,450,000	(\$1,740,650,000)	236,936,200	\$7.35

a. Unescalated, undiscounted costs in 2020 dollars. O&M costs are the totals for the 20-year life cycle period.

b. Total nitrogen load removed calculated from the difference between the annual raw influent TKN load and plant effluent nitrogen load, both based on current rated plant influent flows and loadings, multiplied by 20 for the 20-year life-cycle period.

d. Cost per lb N removed calculated by dividing the 20-year NPV by the total N removed.

## Section 5: Comparison and Ranking of Alternatives

Based on the preliminary site layouts, capital costs, O&M costs, and LCCA results presented above, the alternatives were evaluated using various pre-selected criteria. The preliminary results were presented and discussed with WTD staff in the January 7, 2020, workshop (Workshop 2). The final results incorporate comments from WTD. The following sections summarize the evaluation criteria and results.

### 5.1 Evaluation Criteria and Weighting

Alternatives were compared against both economic and non-economic criteria. Most of these criteria were used in the initial screening of nitrogen removal technologies and in selecting the technology combination alternatives evaluated in this analysis. For evaluation of the final alternatives, a weighting factor was assigned to each criterion. The weighting factor ranged from 1 to 3, with 3 representing the highest weight. For each evaluation criteria, a score ranging from 1 to 10 was assigned to each alternative. The weighted score for that criterion was the product of the raw score and the weighting factor. The following summarizes the criteria and weighting factors used for this analysis.



### **5.1.1 Technology Status**

Technology status refers to how well established the technology is in the industry. During the technology screening process, all embryonic technologies (those that have only started full-scale installation within the last year or have only in-laboratory or pilot-scale installations) were screened out. As all technologies selected for the final alternatives are considered established, a weighting factor of 1 was used for this evaluation criterion.

### **5.1.2 Effluent Nitrogen Load Reduction**

Effluent nitrogen load reduction refers to the total nitrogen load removed across the liquid-stream processes. In the analysis, the TN load removed over a 20-year period was calculated for each alternative. The alternative with the highest TN load removed was assigned a score of 10; scores for the other alternatives were estimated relative to that highest TN load removed. As this is considered an important evaluation criterion, a weighting factor of 3 was assigned.

### **5.1.3 Load Variation Impact**

Load variation impact refers to the impact of, or ability to handle, large variations in load either throughout the day or during storm events. For South Plant, load variation impact is expected to be the same for all alternatives; therefore, a weighting factor of 1 was assigned.

### **5.1.4 Flow Variation Impact**

Flow variation impact refers to the impact of, or ability to handle, large variations in flow either throughout the day or during storm events. As South Plant can experience high flow during storm events, this criterion is considered more than load variation impact. A weighting factor of 2 was assigned.

### **5.1.5 Space for Future Expansion**

Space for future expansion refers to space available for future plant expansion after the new and modified facilities for each alternative are constructed. As this is an important evaluation criterion, a weighting factor of 3 was assigned.

### **5.1.5 Impacts to Other Processes**

This criterion refers to potential impacts to other treatment processes within the WWTP. For this analysis, the impacts were mainly based on total solids production rates, which affect the capacity requirements for the solids treatment processes. A weighting factor of 1 was assigned. In general, lower scores were assigned to Alternatives 2A, 4C, and 4D to reflect the increased solids loads from tertiary nitrogen removal processes (backwash waste solids).

### **5.1.7 GHG Emissions**

This criterion refers to the GHG emissions estimated from energy and chemical usage and nitrous oxide emissions from denitrification processes. A weighting factor of 2 was assigned.

### 5.1.8 Resource Recovery

Resource recovery options include nutrient recovery (nitrogen or phosphorus), flexibility for future reclaimed water production, and energy recovery. For reclaimed water production, alternatives that include membrane or tertiary filtration or have low TN limits (thus allowing groundwater recharge) would have a higher score. As resource recovery is considered a less-important evaluation criterion for this analysis, a weighting factor of 1 was assigned.

### 5.1.9 CEC and Toxics Removal Potential

Compounds of emerging concern (CEC) and toxics removal potential refers to the ability of the treatment processes to remove CEC and toxics. For this analysis, only removals across the mainstream activated sludge process was considered. In general, longer SRT systems (such as the MBR) have higher potential removal, while alternatives with seasonal nitrogen removal have lower potential removal. A weighting factor of 1 was assigned.

### 5.1.10 Capital Cost

Capital costs refer to the total project costs provided in Table 21. Alternative 1, with the least amount of capital improvements and thus the lowest project costs, was assigned a score of 8. Scoring of the other alternatives was made mainly by comparing alternatives within each scenario, and not strictly based on the capital costs for each alternative relative to the capital cost for Alternative 1. A weighting factor of 3 was assigned.

### 5.1.11 O&M Cost

O&M costs include costs for energy use, chemical consumption, and increased labor (FTEs) associated with the mainstream and sidestream processes considered in this evaluation, as shown in Table 22. Alternative 1, with the lowest O&M cost, was assigned a score of 9. Scoring of the other alternatives was made mainly by comparing alternatives within each scenario, and not strictly based on the O&M costs for each alternative relative to the O&M costs for Alternative 1. A weighting factor of 3 was assigned.

### 5.1.12 Supplementary Carbon Source Flexibility

Supplemental carbon source flexibility refers to the potential of the process to use alternatives to purchased external supplemental carbon sources for denitrification, such as methanol and acetic acid. This analysis assumed methanol as the supplemental carbon source for all alternatives to provide a baseline for costing and comparison between alternatives. To reduce operating costs associated with purchasing supplemental carbon, it may be possible to use a carbon source that is generated internally to the plant through fermentation processes, such as primary sludge fermentation; however, primary sludge fermentation would require additional upgrades and infrastructure for the fermentation facilities. In addition, primary sludge fermentation would release additional nitrogen that would be added to the treatment process. For this evaluation, all alternatives considered would be compatible with using primary sludge fermentate in lieu of methanol as the supplemental carbon source or to reduce methanol requirements; however, because fermentate contributes an additional nitrogen load, its use in a tertiary process (such as the tertiary denitrifying filters for some of the alternatives in this analysis) would likely be limited. Similarly, fermentate would be less likely to be used in the second anoxic zone of a 4SMB process when trying to achieve very low effluent TIN limits (e.g., 3 mg/L). In addition, primary sludge fermentation can reduce the relative benefit of sidestream nitrogen removal because of the reduced nitrogen loading to sidestream treatment in the centrate (nitrogen released through fermentation is recycled to the secondary treatment process rather than released in anaerobic digestion where the nitrogen would be available for removal with sidestream treatment). For this reason, alternatives with a tertiary denitrifying process, 4SMB process, or sidestream

treatment were assigned slightly lower scores for supplemental carbon source flexibility. A weighting factor of 2 was assigned to this criterion.

### **5.1.13 Risks**

The risks criterion was added to account for potential risks not already captured as part of the other scoring criteria, such as risks associated with constructing new facilities in the existing flood plain on the east side of the expansion area, a new electrical service to the plant (alternatives with a significantly increased electrical load), and lower-than-expected membrane flux/permeability that restricts secondary treatment capacity (Alternative 4E, which includes conversion to MBR). Potential risks for each alternative are listed in the notes on the preliminary site layouts in Attachment A. They are also included in the description of each alternative in Section 3. A weighting factor of 1 was assigned to this criterion.

### **5.1.14 Constructability**

Constructability refers to the ease of building while minimizing impacts to facility operation and the ability to meet current permit limits. In general, alternatives with higher footprint requirements will have a lower score for constructability. A weighting factor of 3 was assigned.

### **5.1.15 Operational Complexity**

Operational complexity refers to the ease of operating and maintaining the process. For example, a conventional system expansion that results in a process similar to the existing process (such as converting to MLE) would have low operational complexity and be given a higher score. A process that requires significantly more equipment for maintenance, equipment that requires more frequent maintenance, or a process that is more complex to operate and requires additional instrumentation or monitoring to ensure process stability would be given a lower score. A weighting factor of 3 was assigned to this criterion.

## **5.2 Evaluation Results**

The modeling, LCCA, and GHG emissions results for secondary, sidestream, and new tertiary treatment processes for all alternatives are summarized in Table 24; a comparative plot of GHG emissions is shown on Figure 10. For comparison, Figure 10 and Table 24 also show GHG emissions and nitrogen removal performance for the base case, which is defined as similar to Alternative 1A but without sidestream anammox. In general, the greater the amount of nitrogen removed, the higher the GHG emissions. In addition, there is a risk that if electricity use increases significantly from current usage for a given alternative, the County may not be able to purchase all-renewable electricity or may need to pay an additional premium for the additional all-renewable electricity. This situation could increase either the GHG emissions or the operating costs for scenarios 3 and 4 because of significant energy use increases associated with those scenarios compared to current usage. Scoring of all alternatives is summarized on Figure 11.



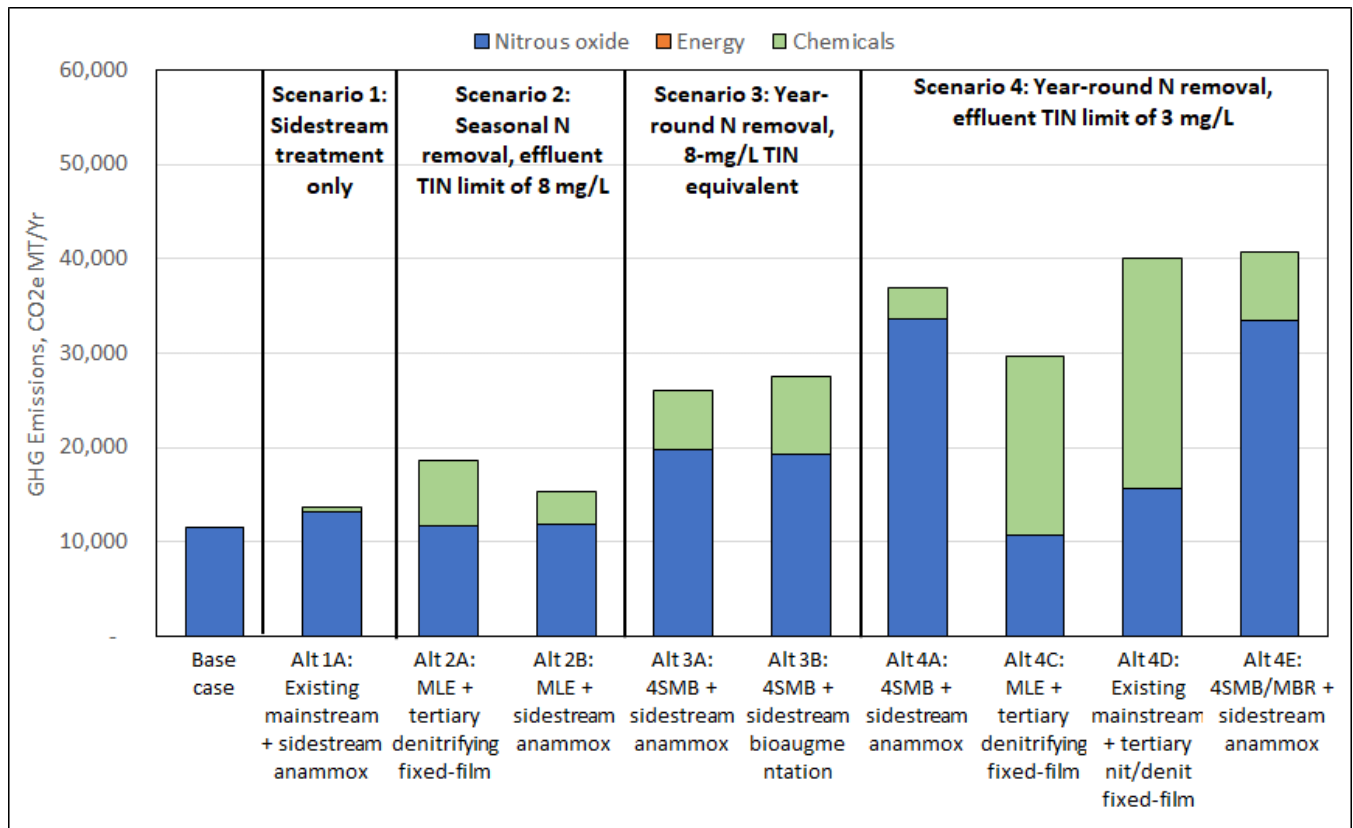

**Figure 10. Comparison of estimated GHG emissions**

*The base case is assumed to be the same as Alternative 1A without sidestream anammox.*

**Table 24. Comparison of Alternatives – Modeling and LCCA Results**

Alternative		Base case <sup>e</sup>	1A	2A	2B	3A	3B	4A	4C	4D	4E
Scenario modifications or effluent limits/targets		-	Sidestream treatment only	Seasonal N removal, effluent TIN limit of 8 mg/L		Year-round N removal, 8-mg/L TIN equivalent		Year-round N removal, effluent TIN limit of 3 mg/L			
Alternative description		Existing mainstream	Existing mainstream + sidestream anammox	MLE + tertiary denitrifying fixed-film	MLE + sidestream anammox	4SMB + sidestream anammox	4SMB + sidestream bioaugmentation	4SMB + sidestream anammox	MLE + tertiary denitrifying fixed-film	Existing mainstream + tertiary nitrifying/denitrifying fixed-film	4SMB/MBR + sidestream anammox
Parameter	Units	Value									
<b>Cost estimates and LCCA results</b>											
Capital cost (total project cost) <sup>a</sup>	-	-	\$87,610,000	\$627,660,000	\$463,860,000	\$711,350,000	\$612,910,000	\$1,024,570,000	\$1,035,750,000	\$1,129,110,000	\$2,037,460,000
O&M cost (20-year) <sup>a, b</sup>	-	-	\$33,370,000	\$108,980,000	\$69,450,000	\$120,660,000	\$164,390,000	\$117,660,000	\$266,380,000	\$345,510,000	\$317,450,000
NPV (20-year)	-	-	(\$86,550,000)	(\$542,870,000)	(\$394,610,000)	(\$613,560,000)	(\$564,510,000)	(\$850,400,000)	(\$947,190,000)	(\$1,065,270,000)	(\$1,740,650,000)
Power consumption	kWh/yr	-	18,836,400	25,736,100	20,869,400	32,134,600	33,259,900	34,897,100	39,358,800	36,117,400	103,961,700
<b>Anticipated performance</b>											
Effluent TIN, summer average	mg/L	21.3	18.0	< 8	7.8	2.9	2.8	2.9	< 3	< 3	2.8
Effluent TIN, winter average	mg/L	41.6	36.3	40.3	34.6	11.9	11.8	3.0	< 3	< 3	2.9
TN removal efficiency, summer average	-	53%	60%	80%	80%	90%	91%	90%	90%	91%	91%
TN removal efficiency, winter average	-	13%	24%	15%	27%	72%	72%	90%	90%	91%	91%
TN removal efficiency, annual average	-	30%	39%	43%	50%	80%	80%	90%	90%	91%	91%
TN removed, annual average	lb/d	10,842	14,084	15,272	17,688	28,544	28,648	32,256	32,132	32,468	32,457
TN removed over 20-year period	lb	79,146,300	102,809,900	111,483,400	129,119,300	208,373,700	209,129,400	235,470,900	234,566,800	237,016,200	236,936,200
Cost of N removal <sup>c</sup>	\$/lb N	-	\$0.84	\$4.87	\$3.06	\$2.94	\$2.70	\$3.61	\$4.04	\$4.49	\$7.35
<b>Biosolids impacts</b>											
WAS production, peak month	lb TSS/d	101,654	98,055	93,630	101,029	98,554	112,690	92,762	101,497	123,720	101,542
Backwash waste solids production, peak month	lb TSS/d	-	-	24,754	-	-	-	-	43,440	80,370	-
Biosolids production, peak month	DT/d	61	60	63	60	54	57	53	65	80	55
<b>Sustainability analysis results</b>											
GHG emissions, nitrous oxide	CO <sub>2</sub> e MT/yr	11,585	13,161	11,619	11,885	19,827	19,287	33,529	10,603	15,611	33,441
GHG emissions, energy	CO <sub>2</sub> e MT/yr	0	0	0	0	0	0	0	0	0	0
GHG emissions, chemicals	CO <sub>2</sub> e MT/yr	0	467	6,918	3,478	6,239	8,229	3,328	19,062	24,490	7,309
GHG emissions, total	CO <sub>2</sub> e MT/yr	11,585	13,628	18,537	15,362	26,066	27,516	36,857	29,664	40,101	40,750
<b>Other considerations</b>											
Implementation timeframe <sup>d</sup>	-	-	5-7 years	8-10 years	8-10 years	8-10 years	8-10 years	10-12 years	10-12 years	8-10 years	10-12 years
Site layout issues/constraints	-	-	See notes on site layouts.								
Implementation challenges or constructability considerations	-	-									

a. Capital and O&M costs are presented in 2020 dollars.

b. O&M costs are for electricity, chemicals, and additional FTEs only.

c. Cost of N removal calculated as TN removed over 20-year period divided by 20-year NPV.

d. Estimated duration for planning, design, and construction.

e. The base case is assumed to be the same as Alternative 1A without sidestream anammox.

Alternative		1A	2A	2B	3A	3B	4A	4C	4D	4E
Scenario modifications or effluent limits/targets		Sidestream treatment only	Seasonal N removal, effluent TIN limit of 8 mg/L		Year-round N removal, 8-mg/L TIN equivalent		Year-round N removal, effluent TIN limit of 3 mg/L			
Alternative description		Existing mainstream + sidestream anammox	MLE + tertiary denitrifying fixed-film	MLE + sidestream anammox	4SMB + sidestream anammox	4SMB + sidestream bioaugmentation	4SMB + sidestream anammox	MLE + tertiary denitrifying fixed-film	Existing mainstream + tertiary nitrifying/denitrifying fixed-film	4SMB/MBR + sidestream anammox
Scoring criteria	Weight <sup>b</sup>	Score <sup>a</sup>								
Technology status	1	10	10	10	10	10	10	10	10	8
Effluent N load reduction	3	3	4	5	8	8	10	10	10	10
Load variation impact	1	6	7	6	6	6	6	7	7	6
Flow variation impact	2	6	6	6	6	6	6	6	6	4
Space for future expansion	3	10	5	7	4	4	1	3	3	7
Impacts to other processes	1	10	5	7	7	6	7	5	4	5
GHG emissions	2	8	6	7	4	4	3	4	3	3
Resource recovery <sup>c</sup>	1	5	6	5	5	5	5	5	5	7
CEC and toxics removal potential <sup>d</sup>	1	4	4	4	6	5	7	5	4	8
Capital cost	3	8	4	7	5	7	6	6	5	1
O&M cost	3	9	5	8	7	4	7	3	1	2
Supplemental carbon source flexibility	2	4	4	6	5	7	5	4	2	5
Risks	1	10	5	6	6	5	4	5	5	2
Constructability	3	10	5	6	6	5	4	5	5	5
Operational complexity	3	8	6	7	6	6	6	6	4	3
<b>Total un-weighted score</b>		<b>111</b>	<b>82</b>	<b>97</b>	<b>91</b>	<b>88</b>	<b>87</b>	<b>84</b>	<b>74</b>	<b>76</b>
<b>Total weighted score</b>		<b>225</b>	<b>156</b>	<b>196</b>	<b>178</b>	<b>173</b>	<b>169</b>	<b>164</b>	<b>141</b>	<b>144</b>

- Notes:
- a. Score of 1 to 10, where 10 represents the greatest benefit or lowest cost, footprint, emissions, etc.
  - b. Score of 1 to 3, where 3 represents the highest weighting factor.
  - c. Resource recovery includes nutrient recovery (N or P), flexibility for future reclaimed water production (TN limits, filtration, etc.), energy recovery, etc.
  - d. CEC and toxics removal potential only considers the mainstream activated sludge process. In general, longer SRT systems (MBR) have higher potential removal, while seasonal N removal options have lower potential.

Figure 11. Comparison of alternatives – scoring results

## Section 6: Summary

Rather than selecting preferred alternatives for each nitrogen removal scenario, the task team decided during Workshop 2 that the evaluation results would be most beneficial if used to represent a range of potential costs and other impacts for each scenario. This approach recognizes that future alternatives evaluations would be required during planning and design to select the preferred upgrade approach for South Plant once actual nitrogen limits and the timing of nitrogen limits are known. Overall, key conclusions from the South Plant analysis of planning alternatives include:

- Retaining the existing mainstream treatment process and adding sidestream nitrogen removal (anammox) would provide the lowest overall cost of nitrogen removal on a per unit basis; however, adding sidestream treatment alone only reduces the annual average effluent TIN by about 5 mg/L and may not achieve expected potential effluent TIN limits, either on a seasonal or year-round basis, even with summer operation of the mainstream process in a partial nitrifying/denitrifying configuration. Sidestream treatment could be a precursor to mainstream or tertiary nitrogen removal upgrades.
- Seasonal nitrogen removal with an effluent TIN limit of 8 mg/L (scenario 2) can be achieved with mainstream process upgrades or a combination of mainstream process upgrades and addition of tertiary nitrogen removal, with addition of sidestream nitrogen removal applicable to either approach. For this analysis of planning alternatives, two alternatives were evaluated for seasonal nitrogen removal: MLE with tertiary denitrifying fixed-film (Alternative 2A) and MLE with sidestream anammox (Alternative 2B).
  - Results indicate that either alternative could fit within the existing South Plant site while allowing footprint for future expansion.
  - Tertiary denitrification likely has minimal benefit for a seasonal nitrogen removal scenario at South Plant because it still requires expanding the mainstream activated sludge process to achieve full nitrification during the shoulder season. The modeling results for this analysis showed that total required aeration basin volume for Alternative 2A with tertiary nitrogen removal was approximately 15 percent lower than Alternative 2B, but Alternative 2A required significantly higher chemical addition, especially for alkalinity.
  - Capital costs for seasonal nitrogen removal alternatives range from approximately \$464 million (Alternative 2B) to \$628 million (Alternative 2A), and up to 300 percent higher (\$1.86 to \$2.51 billion) based on the upper end of the cost estimate accuracy range.
- Year-round nitrogen removal with an effluent TIN limit of 8 mg/L (scenario 3) can be achieved using a similar approach to that required for seasonal nitrogen removal. For this analysis of planning alternatives, two alternatives were evaluated for year-round nitrogen removal at an effluent TIN limit of 8 mg/L: 4SMB with sidestream anammox (Alternative 3A) and 4SMB with sidestream bioaugmentation (Alternative 3B).
  - Results indicate that either alternative could fit within the existing South Plant site, but both alternatives would have limited available space for future expansion of aeration basins.
  - In general, 4SMB with sidestream anammox would have reduced O&M costs relative to 4SMB with sidestream bioaugmentation (approximately 30 percent lower based on modeling results).
  - Capital costs for year-round nitrogen removal alternatives with an effluent TIN limit of 8 mg/L range from approximately \$613 million (Alternative 3B) to \$711 million (Alternative 2A), and up to 300 percent higher (\$2.45 to \$2.85 billion) based on the upper end of the cost estimate accuracy range.

- Estimated costs (for both capital and operating) and GHG emissions would increase from the values for scenario 2, but the incremental increases in capital costs are relatively small. Other than scenario 1, this scenario has the lowest cost per pound of nitrogen removed.
- Because of the lower capital costs, results suggest an approximately 10 percent lower cost of nitrogen removal for sidestream bioaugmentation, despite the higher O&M costs. Sidestream bioaugmentation, however, would likely have overall increased complexity associated with RAS conveyance and integration with the mainstream process expansion. Sidestream treatment alternatives would require further evaluation during a detailed alternatives analysis.
- While remaining within the existing South Plant site, year-round nitrogen removal with an effluent TIN limit of 3 mg/L (scenario 4) will likely be difficult for South Plant without using an intensification technology to reduce footprint requirements of the mainstream process and/or adding tertiary nitrogen removal. For this analysis of planning alternatives, four alternatives were evaluated for year-round nitrogen removal at an effluent TIN limit of 3 mg/L: 4SMB with sidestream anammox (Alternative 4A), MLE with tertiary denitrifying fixed-film (Alternative 4C), existing mainstream with tertiary nitrifying/denitrifying fixed-film (Alternative 4D), and 4SMB/MBR with sidestream anammox (Alternative 4E).
  - Results indicate that the required volume of new aeration basins for Alternative 4A would consume all existing available site space for secondary treatment expansion, leaving no available space for future aeration basin or secondary clarifier expansion without new land acquisition. Therefore, from a site footprint perspective, alternatives that include tertiary nitrogen removal (Alternatives 4C and 4D) or mainstream process intensification (Alternative 4E) are likely most feasible without reducing plant capacity; of these, Alternative 4C has the lowest overall cost of nitrogen removal.
  - Alternative 4E (MBR) would eliminate the need for the existing secondary clarifiers and, therefore, would have potential to free additional site space for future expansion. However, full conversion to an MBR process would make South Plant the largest MBR facility in the United States (by over three times in design capacity based on current installations) and one of the largest MBR facilities in the world,
  - Capital costs for year-round nitrogen removal alternatives with an effluent TIN limit of 3 mg/L are similar for Alternatives 4A, 4C, and 4D, ranging from approximately \$1.02 to \$1.13 billion, and up to 300 percent higher (\$4.10 to \$4.52 billion) based on the upper end of the cost estimate accuracy range. The capital cost for Alternative 4E is significantly higher at approximately \$2.04 billion (or up to \$8.15 billion at +300 percent).
- Results from this study indicate that as the level of nitrogen removal increases, costs for labor (expressed as additional FTEs), power, and chemicals would generally increase. The exception is Alternative 4A (4SMB + sidestream anammox), which has lower chemical costs than Alternative 3A (also 4SMB + sidestream anammox but with a lower effluent TIN limit) because of the significantly more reduction in alkalinity demand than the increase in methanol demand. GHG emissions also follow an increasing trend as the level of nitrogen removal increases,
- The scenario 3 and 4 alternatives were shown to result in significantly higher power demand than Alternative 1A. The estimated power demand for Alternative 4E, with conversion to MBR, is more than 5 times of the power demand for Alternative 1A. King County is currently contracted to purchase all-renewable electricity from Puget Sound Energy for South Plant. However, there is a risk that if electricity use increases from current usage significantly for a given alternative, the County may not be able to purchase all-renewable electricity or may need to pay an additional premium for the additional all-renewable electricity. This would increase either the GHG emissions or the operating costs for those alternatives.

- While this study provides the range of planning-level information to meet different limits, future studies can supplement the results of this study by considering advancements in nitrogen removal technologies, particularly intensification processes such as hybrid fixed-film/ballast processes or membrane aerated biofilm reactors. Evaluation of other intensification technologies (besides MBR) will be especially relevant to Scenario 4 to meet the low TIN limit.
- All modeling and sizing conducted for this study was based on the current rated flows and loads for South Plant. Further evaluation would be needed to assess impacts of operation at actual and projected flows and loads.

## Attachment A: Site Layouts

---







NEW SUPPLEMENTAL ALKALINITY SYSTEM

ALKALINITY TO SIDESTREAM ANAMMOX

NEW SIDESTREAM ANAMMOX SYSTEM

CENTRATE TO SIDESTREAM ANAMMOX

ANAMMOX EFFLUENT TO EXISTING THICKENER OVERFLOW PIPING



Implementation challenges or constructibility considerations:  
-Can be constructed with minimal impacts to existing plant operations  
  
Risks:  
-Provides limited overall nitrogen removal

NOTE: SITE LAYOUT DESIGNED FOR CURRENT PLANT RATED CAPACITY.



SOUTH TREATMENT PLANT NITROGEN REMOVAL STUDY  
SCENARIO 1: SIDESTREAM TREATMENT, NITRIFICATION/DENITRIFICATION DURING SUMMER  
ALT 1A: EXISTING MAINSTREAM + SIDESTREAM ANAMMOX

SCALE:  
1" = 200'







NEW TERTIARY FEED PUMP STATION  
NEW TERTIARY FEED PUMP STATION ELECTRICAL BUILDING

RESERVED SPACE FOR FUTURE EXPANSION

BACKWASH WASTE TO NORTH PRIMARY DISTRIBUTION CHANNEL

NEW AERATION BASINS (8,544 MGAL TOTAL, 22' SWD)

ML TO SECONDARY CLARIFIERS

RAS TO AERATION BASINS

PE TO AERATION BASINS

EXISTING AERATION BASINS CONVERTED TO MLE (15' SWD)

EXISTING RAS CHANNELS

EXISTING ML CHANNELS

BULKHEAD EXISTING CHLORINE CONTACT CHANNEL



SE TO TERTIARY CELLS

NEW TERTIARY DENITRIFYING FIXED-FILM SYSTEM

TERTIARY EFFLUENT TO NEW CHLORINE CONTACT CHANNEL

TERTIARY FEED PUMP STATION BYPASS/OVERFLOW

RESERVED SPACE FOR FUTURE EXPANSION

SE TO TERTIARY FEED PUMP STATION

EXISTING CHLORINE CONTACT CHANNEL

METHANOL TO AERATION BASINS AND TERTIARY

ALKALINITY TO RAS MIXING BOX

NEW CHLORINE CONTACT CHANNEL (FROM TERTIARY)

NEW SUPPLEMENTAL METHANOL SYSTEM

NEW SUPPLEMENTAL ALKALINITY SYSTEM

**Site layout issues/constraints:**  
 -Assumes that existing north chlorine contact channel can be reconfigured to convey secondary effluent from existing secondary clarifiers to the tertiary feed pump station  
 -Conveyance challenges for flow distribution between new and existing aeration basins

**Implementation challenges or constructibility considerations:**  
 -Construction of new aeration basins can likely be completed with minimal impacts to current plant operations  
 -Construction of new tertiary systems can likely be completed with minimal impacts to current plant operations  
 -Requires demolition of existing storage building and relocation of construction trailer for construction of new aeration basins

**Risks:**  
 -Includes construction of new facilities in existing flood plain on the east side of the expansion area

NOTE: SITE LAYOUT DESIGNED FOR CURRENT PLANT RATED CAPACITY.



SOUTH TREATMENT PLANT NITROGEN REMOVAL STUDY  
 SCENARIO 2: SEASONAL NITROGEN REMOVAL, EFFLUENT TIN LIMIT OF 8 MG/L  
 ALT 2A: MLE + TERTIARY DENITRIFYING FIXED-FILM

SCALE:  
1" = 200'







RESERVED SPACE FOR FUTURE EXPANSION

NEW SIDESTREAM ANAMMOX SYSTEM

CENTRATE TO SIDESTREAM ANAMMOX

ANAMMOX EFFLUENT TO EXISTING THICKENER OVERFLOW PIPING

ML TO SECONDARY CLARIFIERS

RAS TO AERATION BASINS

PE TO AERATION BASINS

EXISTING AERATION BASINS CONVERTED TO MLE (15' SWD)

EXISTING RAS CHANNELS

EXISTING ML CHANNELS

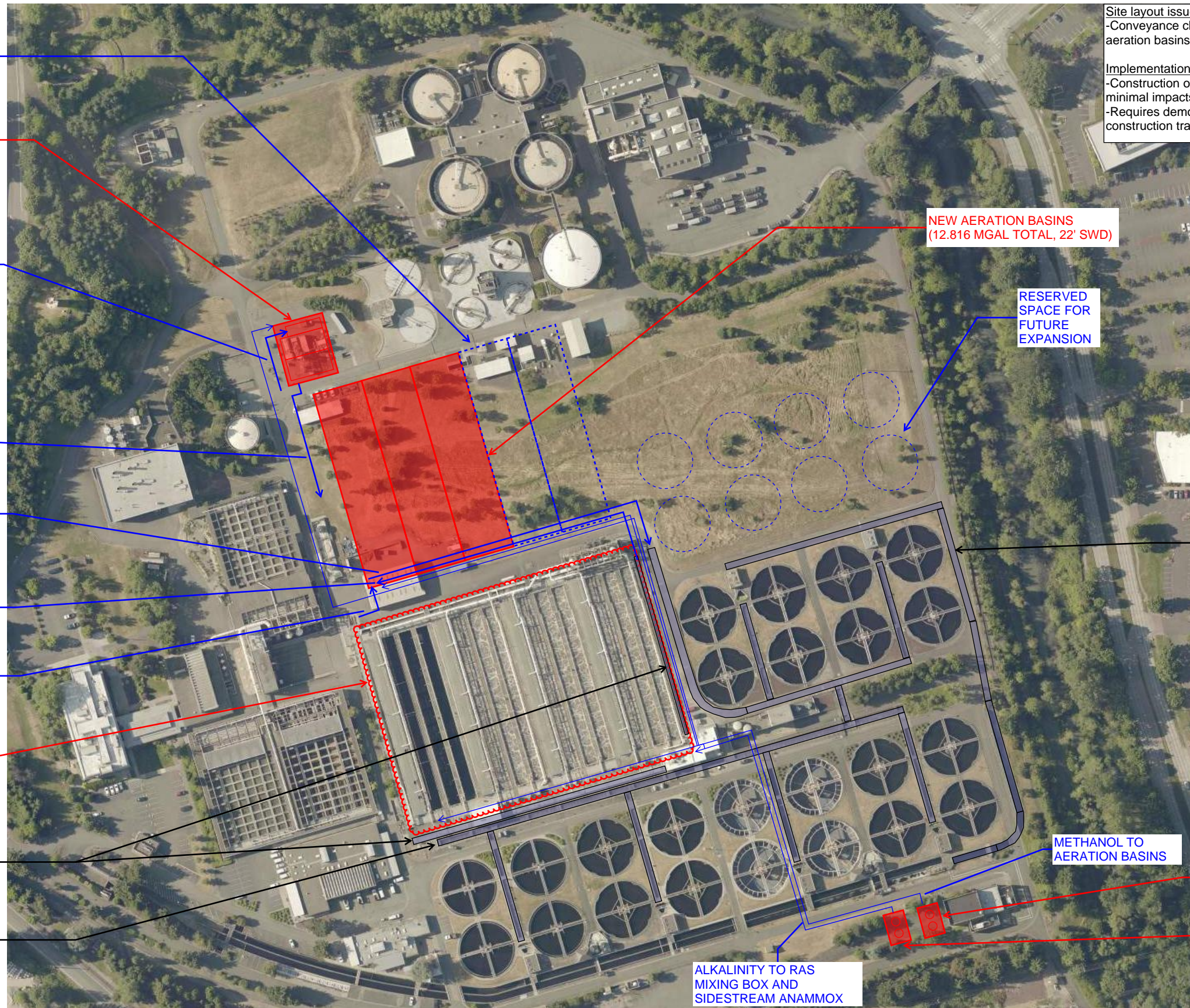

Site layout issues/constraints:  
-Conveyance challenges for flow distribution between new and existing aeration basins  
  
Implementation challenges or constructibility considerations:  
-Construction of new aeration basins can likely be completed with minimal impacts to current plant operations  
-Requires demolition of existing storage building and relocation of construction trailers for construction of new aeration basins

NEW AERATION BASINS (12.816 MGAL TOTAL, 22' SWD)

RESERVED SPACE FOR FUTURE EXPANSION

EXISTING CHLORINE CONTACT CHANNEL

METHANOL TO AERATION BASINS

NEW SUPPLEMENTAL METHANOL SYSTEM

NEW SUPPLEMENTAL ALKALINITY SYSTEM

ALKALINITY TO RAS MIXING BOX AND SIDESTREAM ANAMMOX

NOTE: SITE LAYOUT DESIGNED FOR CURRENT PLANT RATED CAPACITY.





NEW AERATION BASINS  
(29.904 MGAL TOTAL, 22' SWD)

NEW SIDESTREAM  
ANAMMOX SYSTEM

CENTRATE TO  
SIDESTREAM  
ANAMMOX

ANAMMOX EFFLUENT TO  
EXISTING THICKENER  
OVERFLOW PIPING

ML TO  
SECONDARY  
CLARIFIERS

RAS TO  
AERATION  
BASINS

PE TO  
AERATION  
BASINS

EXISTING AERATION BASINS  
CONVERTED TO 4SMB (15' SWD)

EXISTING RAS CHANNELS

EXISTING ML CHANNELS

RESERVED  
SPACE FOR  
FUTURE  
EXPANSION

Site layout issues/constraints:  
-Conveyance challenges for flow distribution between new and existing aeration basins

Implementation challenges or constructibility considerations:  
-Construction of new aeration basins can likely be completed with minimal impacts to current plant operations  
-Requires demolition of existing storage buildings and relocation of construction trailers for construction of new aeration basins

Risks:  
-Limited available space for aeration basin expansion

EXISTING CHLORINE  
CONTACT CHANNEL

METHANOL TO  
AERATION  
BASINS

NEW SUPPLEMENTAL  
METHANOL SYSTEM

NEW SUPPLEMENTAL  
ALKALINITY SYSTEM

ALKALINITY TO RAS  
MIXING BOX AND  
SIDESTREAM ANAMMOX

NOTE: SITE LAYOUT DESIGNED FOR  
CURRENT PLANT RATED CAPACITY.



SOUTH TREATMENT PLANT NITROGEN REMOVAL STUDY  
SCENARIO 3: YEAR-ROUND NITROGEN REMOVAL, 8-MG/L TIN EQUIVALENT  
ALT 3A: 4SMB + SIDESTREAM ANAMMOX

SCALE:  
1" = 200'







CENTRATE TO  
SIDESTREAM BAR

NEW AERATION BASINS  
(25.632 MGAL TOTAL, 22' SWD)

ML TO  
SECONDARY  
CLARIFIERS

RAS TO  
AERATION  
BASINS

PE TO  
AERATION  
BASINS

EXISTING AERATION BASINS  
CONVERTED TO 4SMB (15' SWD)

EXISTING RAS CHANNELS

EXISTING ML CHANNELS

RESERVED  
SPACE FOR  
FUTURE  
EXPANSION

Site layout issues/constraints:  
-Conveyance challenges for flow distribution between new and existing aeration basins  
-Conveyance challenges for routing RAS to/from sidestream bioaugmentation tank  
-Assumes it will be possible to use existing RAS pumps to pump portion of RAS to sidestream bioaugmentation tank (tying into four of the existing RAS headers in the RAS gallery and routing new piping to sidestream treatment)

Implementation challenges or constructibility considerations:  
-Construction of new aeration basins can likely be completed with minimal impacts to current plant operations  
-Requires demolition of existing storage buildings and relocation of construction trailers for construction of new aeration basins

Risks:  
-Limited available space for aeration basin expansion

NEW SIDESTREAM  
BIOAUGMENTATION TANK

EXISTING CHLORINE  
CONTACT CHANNEL

RAS TO  
SIDESTREAM BAR

BAR EFFLUENT TO  
RAS CHANNEL

METHANOL TO  
AERATION BASINS

NEW SUPPLEMENTAL  
METHANOL SYSTEM

NEW SUPPLEMENTAL  
ALKALINITY SYSTEM

ALKALINITY TO RAS  
MIXING BOX AND  
SIDESTREAM BAR

NOTE: SITE LAYOUT DESIGNED FOR  
CURRENT PLANT RATED CAPACITY.

**Brown AND  
Caldwell**

SOUTH TREATMENT PLANT NITROGEN REMOVAL STUDY  
SCENARIO 3: YEAR-ROUND NITROGEN REMOVAL, 8-MG/L TIN EQUIVALENT  
ALT 3B: 4SMB + SIDESTREAM BIOAUGMENTATION

SCALE:  
1" = 200'







NEW SIDESTREAM ANAMMOX SYSTEM

CENTRATE TO SIDESTREAM ANAMMOX

ANAMMOX EFFLUENT TO EXISTING THICKENER OVERFLOW PIPING

ML TO SECONDARY CLARIFIERS

RAS TO AERATION BASINS

PE TO AERATION BASINS

EXISTING AERATION BASINS CONVERTED TO 4SMB (15' SWD)

EXISTING RAS CHANNELS

EXISTING ML CHANNELS

NEW AERATION BASINS (55.536 MGAL TOTAL, 22' SWD)

ML TO SECONDARY CLARIFIERS

RAS TO AERATION BASINS

EXISTING CHLORINE CONTACT CHANNEL

METHANOL TO AERATION BASINS

NEW SUPPLEMENTAL METHANOL SYSTEM

NEW SUPPLEMENTAL ALKALINITY SYSTEM

ALKALINITY TO RAS MIXING BOX AND SIDESTREAM ANAMMOX

Site layout issues/constraints:  
 -Conveyance challenges for flow distribution between new and existing aeration basins

Implementation challenges or constructibility considerations:  
 -Construction of new aeration basins can likely be completed with minimal impacts to current plant operations  
 -Requires demolition of existing storage buildings and relocation of construction trailers for construction of new aeration basins

Risks:  
 -No available space for aeration basin or secondary clarifier expansion  
 -Includes construction of new facilities in existing flood plain on the east side of the expansion area

NOTE: SITE LAYOUT DESIGNED FOR CURRENT PLANT RATED CAPACITY.





NEW AERATION BASINS  
(25.632 MGAL TOTAL, 22' SWD)

BACKWASH WASTE TO  
NORTH PRIMARY  
DISTRIBUTION  
CHANNEL

ML TO  
SECONDARY  
CLARIFIERS

RAS TO  
AERATION  
BASINS

PE TO  
AERATION  
BASINS

EXISTING AERATION BASINS  
CONVERTED TO MLE (15' SWD)

EXISTING RAS CHANNELS

EXISTING ML CHANNELS

BULKHEAD EXISTING CHLORINE  
CONTACT CHANNEL



NEW TERTIARY  
DENITRIFYING  
FIXED-FILM SYSTEM

TERTIARY EFFLUENT  
TO NEW CHLORINE  
CONTACT CHANNEL

TERTIARY FEED  
PUMP STATION  
BYPASS/OVERFLOW

RESERVED  
SPACE FOR  
FUTURE  
EXPANSION

SE TO  
TERTIARY  
FEED PUMP  
STATION

EXISTING CHLORINE  
CONTACT CHANNEL

NEW TERTIARY FEED PUMP  
STATION

NEW TERTIARY FEED PUMP  
STATION ELECTRICAL  
BUILDING

NEW CHLORINE CONTACT  
CHANNEL (FROM TERTIARY)

METHANOL TO  
AERATION BASINS  
AND TERTIARY

NEW SUPPLEMENTAL  
METHANOL SYSTEM

NEW SUPPLEMENTAL  
ALKALINITY SYSTEM

ALKALINITY TO  
RAS MIXING BOX

Site layout issues/constraints:  
-Conveyance challenges for flow distribution between new and existing aeration basins  
-Assumes that existing north chlorine contact channel can be reconfigured to convey secondary effluent from existing secondary clarifiers to the tertiary feed pump station

Implementation challenges or constructibility considerations:  
-Construction of new aeration basins can likely be completed with minimal impacts to current plant operations  
-Construction of new tertiary systems can likely be completed with minimal impacts to current plant operations  
-Requires demolition of existing storage buildings and relocation of construction trailers for construction of new aeration basins

Risks:  
-No available space for aeration basin expansion  
-Includes construction of new facilities in existing flood plain on the east side of the expansion area

NOTE: SITE LAYOUT DESIGNED FOR  
CURRENT PLANT RATED CAPACITY.



SOUTH TREATMENT PLANT NITROGEN REMOVAL STUDY  
SCENARIO 4: YEAR-ROUND NITROGEN REMOVAL, EFFLUENT TIN LIMIT OF 3 MG/L  
ALT 4C: MLE + TERTIARY DENITRIFYING FIXED-FILM

SCALE:  
1" = 200'







NEW TERTIARY NITRIFYING  
FIXED-FILM SYSTEM

BACKWASH WASTE TO  
NORTH PRIMARY  
DISTRIBUTION  
CHANNEL

RESERVED SPACE FOR  
FUTURE  
EXPANSION

SE TO TERTIARY  
NITRIFICATION

EXISTING RAS CHANNELS

EXISTING ML CHANNELS

BULKHEAD EXISTING CHLORINE  
CONTACT CHANNEL



TERTIARY EFFLUENT  
TO NEW CHLORINE  
CONTACT CHANNEL

NEW TERTIARY  
DENITRIFYING  
FIXED-FILM SYSTEM

TERTIARY FEED  
PUMP STATION  
BYPASS/OVERFLOW

RESERVED SPACE FOR  
FUTURE  
EXPANSION

SE TO  
TERTIARY  
FEED PUMP  
STATION

EXISTING CHLORINE  
CONTACT CHANNEL

NEW TERTIARY FEED PUMP  
STATION

NEW TERTIARY FEED PUMP  
STATION ELECTRICAL  
BUILDING

NEW CHLORINE CONTACT  
CHANNEL (FROM TERTIARY)

METHANOL TO  
TERTIARY  
DENITRIFICATION

NEW SUPPLEMENTAL  
METHANOL SYSTEM

NEW SUPPLEMENTAL  
ALKALINITY SYSTEM

ALKALINITY TO TERTIARY  
NITRIFICATION

Site layout issues/constraints:  
-Assumes that existing north chlorine contact channel can be reconfigured to convey secondary effluent from existing secondary clarifiers to the tertiary feed pump station

Implementation challenges or constructibility considerations:  
-Construction of new tertiary systems can likely be completed with minimal impacts to current plant operations  
-Requires demolition of existing storage building and relocation of construction trailer for construction of new tertiary systems

Risks:  
-Limited available space for aeration basin and secondary clarifier expansion  
-Includes construction of new facilities in existing flood plain on the east side of the expansion area

NOTE: SITE LAYOUT DESIGNED FOR  
CURRENT PLANT RATED CAPACITY.



SOUTH TREATMENT PLANT NITROGEN REMOVAL STUDY  
SCENARIO 4: YEAR-ROUND NITROGEN REMOVAL, EFFLUENT TIN LIMIT OF 3 MG/L  
ALT 4D: EXISTING MAINSTREAM + TERTIARY NITRIFYING/DENITRIFYING FIXED-FILM

SCALE:  
1" = 200'







RESERVED SPACE FOR FUTURE EXPANSION

NEW AERATION BASINS (12.816 MGAL TOTAL, 22' SWD)

NEW SIDESTREAM ANAMMOX SYSTEM

CENTRATE TO SIDESTREAM ANAMMOX

RAS TO AERATION BASINS

ANAMMOX EFFLUENT TO EXISTING THICKENER OVERFLOW PIPING

NEW PRIMARY EFFLUENT FINE SCREENING

NEW PRIMARY EFFLUENT PUMP STATION

PE TO SCREENING FACILITY

PE TO AERATION BASINS

EXISTING AERATION BASINS CONVERTED TO 4SMB (15' SWD)

ML TO MEMBRANE FEED PUMP STATION

EXISTING RAS CHANNELS

EXISTING ML CHANNELS

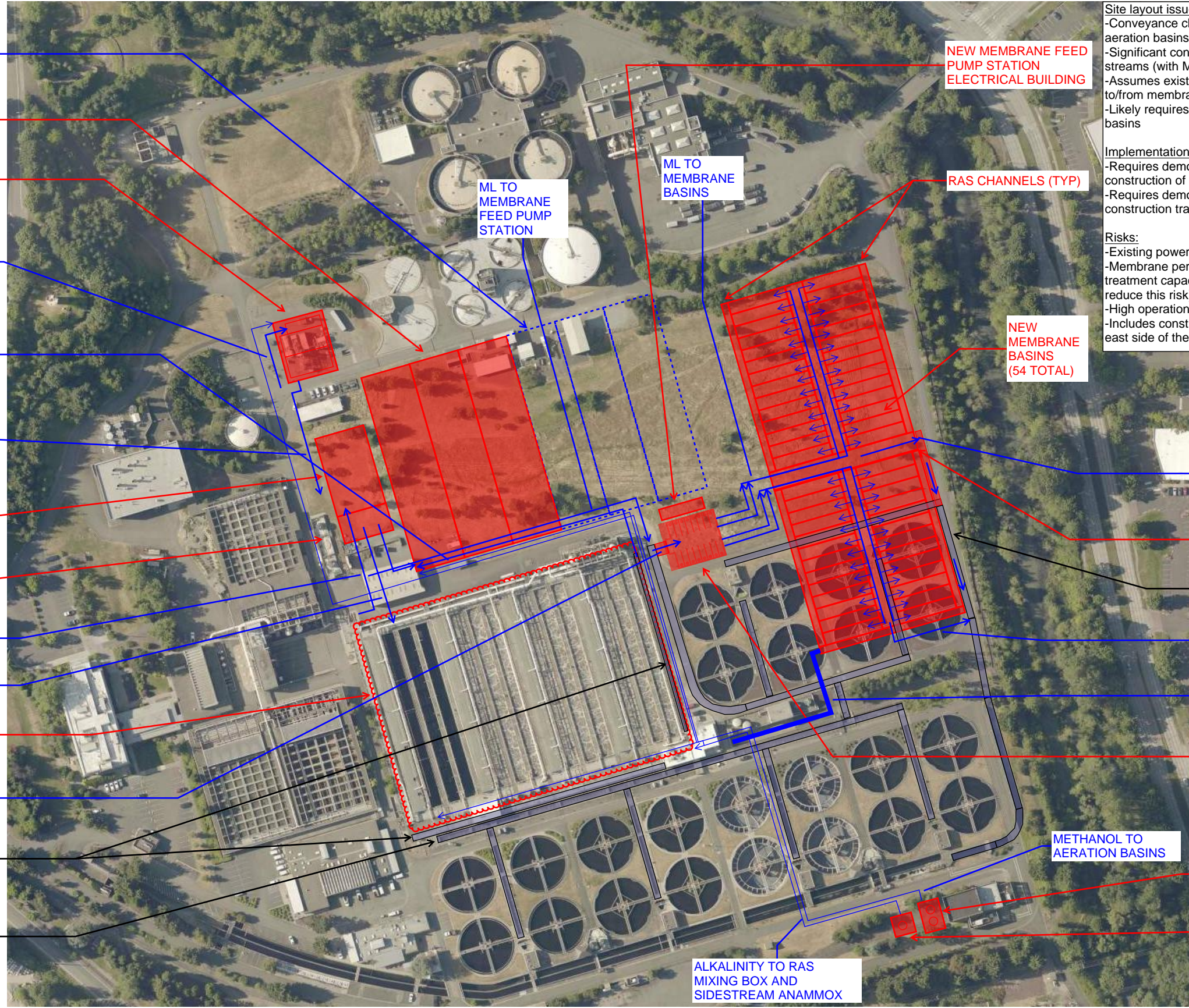

NEW MEMBRANE FEED PUMP STATION ELECTRICAL BUILDING

ML TO MEMBRANE FEED PUMP STATION

ML TO MEMBRANE BASINS

RAS CHANNELS (TYP)

NEW MEMBRANE BASINS (54 TOTAL)

MEMBRANE PERMEATE TO CHLORINE CONTACT CHANNEL

MEMBRANE EQUIPMENT AND PIPING GALLERY (TYP)

EXISTING CHLORINE CONTACT CHANNEL

MEMBRANE PERMEATE TO CHLORINE CONTACT CHANNEL

RAS TO EXISTING RAS CHANNEL

NEW MEMBRANE FEED PUMP STATION

METHANOL TO AERATION BASINS

NEW SUPPLEMENTAL METHANOL SYSTEM

NEW SUPPLEMENTAL ALKALINITY SYSTEM

ALKALINITY TO RAS MIXING BOX AND SIDESTREAM ANAMMOX

Site layout issues/constraints:

- Conveyance challenges for flow distribution between new and existing aeration basins
- Significant conveyance challenges associated with PE, ML, and RAS streams (with ML at 5Q and RAS at 4Q)
- Assumes existing ML and RAS channels can be used for conveyance to/from membrane basins
- Likely requires above-grade routing of large RAS conduits to aeration basins

Implementation challenges or constructibility considerations:

- Requires demolition of at least one pod of secondary clarifiers for construction of membrane basins
- Requires demolition of existing storage building and relocation of construction trailer for construction of new aeration basins

Risks:

- Existing power supply insufficient for increased electrical loads
- Membrane permeability lower than design value limits secondary treatment capacity (conservative flux limit used for site layout to reduce this risk)
- High operational complexity
- Includes construction of new facilities in existing flood plain on the east side of the expansion area

NOTE: SITE LAYOUT DESIGNED FOR CURRENT PLANT RATED CAPACITY.



## **Attachment B: Greenhouse Gas Emissions Results and Literature Review of Nitrous Oxide Emission Factors**

---



	Alternative	Annual Averages								
		1A	2A	2B	3A	3B	4A	4C	4D	4E
	Alternative Type	Existing mainstream + sidestream anammox	MLE + tertiary denitrifying fixed-film	MLE + sidestream anammox	4SMB + sidestream anammox	4SMB + sidestream bioaugmentation	4SMB + sidestream anammox	MLE + tertiary denitrifying fixed-film	Existing mainstream + tertiary nitrifying/denitrifying fixed-film	4SMB/MBR + sidestream anammox
Operational Parameters	Power Consumption (Kwh/yr)	18,836,412	25,736,148	20,869,393	32,134,565	33,259,894	34,897,098	39,358,839	36,117,414	103,961,741
	Prod. Emissions (CO2e MT/yr)	-	-	-	-	-	-	-	-	-
	Supplemental Chemicals									
	Sodium Hypochlorite (gal/yr)	-	-	-	-	-	-	-	-	357,577
	Prod. Emissions (CO2e MT/yr)	-	-	-	-	-	-	-	-	1,006
	Transportation (CO2e MT/yr)	-	-	-	-	-	-	-	-	11
	Citric Acid (gal/yr)	-	-	-	-	-	-	-	-	42,462
	Prod. Emissions (CO2e MT/yr)	-	-	-	-	-	-	-	-	82
	Transportation (CO2e MT/yr)	-	-	-	-	-	-	-	-	1
	Alkalinity (25% Caustic) (gal/yr)	167,789	2,189,985	1,087,670	1,803,543	1,916,235	524,145	5,474,985	6,478,750	523,944
	Prod. Emissions (CO2e MT/yr)	442	5,774	2,868	4,755	5,052	1,382	14,435	17,082	1,381
	Transportation (CO2e MT/yr)	25	65.7	32.6	54.1	57.5	15.7	164.2	194.4	15.7
	Methanol (gal/yr)	-	529,250	283,263	701,811	1,530,787	947,448	2,190,000	3,540,500	2,362,142
	Prod. Emissions (CO2e MT/yr)	-	1,062	569	1,409	3,073	1,902	4,396	7,107	4,742
Transportation (CO2e MT/yr)	-	15.9	8.5	21.1	45.9	28.4	65.7	106.2	70.9	
Supplemental Chemical Subtotal (CO2e MT/yr)	467	6,918	3,478	6,239	8,229	3,328	19,062	24,490	7,309	
Modeled Parameters	Influent TN Load (lb/d)	-	-	-	-	-	-	-	-	-
	Secondary TN Load (Lb/d), Average	36,129	40,866	36,362	36,059	40,498	36,011	40,309	40,520	35,778
	Mainstream (AO, MLE, 4SMB) - Summer									
	Influent TN Load (lb/d)	31,348	35,592	31,426	31,281	35,670	31,281	35,592	35,549	31,125
	Effluent TN Load (lb/d)	13,309	12,900	6,604	3,170	3,107	3,170	12,900	15,628	2,971
	Mainstream (AO, MLE, 4SMB) - Winter									
	Influent TN Load (lb/d)	40,910	46,139	41,299	40,837	45,327	40,740	45,026	45,491	40,432
	Effluent TN Load (lb/d)	32,695	36,912	31,876	11,997	11,891	4,149	21,947	37,453	3,896
	Tertiary Treatment									
	Influent TN Load (lb/d)	-	24,906	-	-	-	-	17,424	26,541	-
	Effluent TN Load (lb/d)	-	21,820	-	-	-	-	3,796	3,445	-
Sidestream										
Influent TN Load (lb/d)	6,079	-	6,348	5,836	6,097	5,766	-	-	5,759	
Effluent TN Load (lb/d)	1,809	-	1,889	1,737	6,097	1,716	-	-	1,714	
Effluent TN Load (lb/d)	23,002	21,820	19,240	7,584	7,499	3,660	3,796	3,445	3,434	
Nitrous Oxide Emissions	N2O Emissions, Process (CO2e MT/Yr)	5,215	4,081	5,238	17,207	16,697	32,265	9,292	14,421	32,255
	Mainstream (AO, MLE, 4SMB) (CO2e MT/Yr) - Summer	1,583	1,254	1,372	12,818	14,849	12,818	1,254	1,748	12,838
	Mainstream (AO, MLE, 4SMB) (CO2e MT/Yr) - Winter	721	810	827	1,594	1,848	16,685	1,276	705	16,660
	Tertiary (Fixed-Film FilterS) (CO2e MT/Yr)	-	7,612	-	-	-	-	25,516	45,161	-
	Sidestream (CO2e MT/Yr)	2,911	-	3,040	2,794	-	2,761	-	-	2,757
	N2O Emissions, Effluent Nitrogen Discharge (CO2e MT/Yr)	7,946	7,538	6,646	2,620	2,591	1,264	1,311	1,190	1,186
	Total N2O Emissions, Plant (CO2e MT/Yr)	13,161	11,619	11,885	19,827	19,287	33,529	10,603	15,611	33,441
GHG Emissions	Nitrous oxide	13,161	11,619	11,885	19,827	19,287	33,529	10,603	15,611	33,441
	Energy	-	-	-	-	-	-	-	-	-
	Chemicals	467	6,918	3,478	6,239	8,229	3,328	19,062	24,490	7,309
	<b>Total (CO2e MT/Yr)</b>	<b>13,628</b>	<b>18,537</b>	<b>15,362</b>	<b>26,066</b>	<b>27,516</b>	<b>36,857</b>	<b>29,664</b>	<b>40,101</b>	<b>40,750</b>

GHG Emissions/ N removed, CO2e MT/MT N removed

6.27	5.88	5.42	5.53	5.03	6.88	4.91	6.53	7.61
------	------	------	------	------	------	------	------	------

GHG Emission Factor	Value	Unit	Note	Source/Reference
Methane	28	gCO2e/gCH4		IPCC (2014). Climate Change 2014 Synthesis Report Fifth Assessment Report
Nitrous Oxide	265	gCO2e/gN2O		IPCC (2014). Climate Change 2014 Synthesis Report Fifth Assessment Report
Sodium Hydroxide (Caustic Soda), 25%	0.505	kg CO2e/kg	Production emissions	EPA, 2016. LCI data - Treatment Chemicals, Construction Materials, Transportation, onsite equipment and othe processes for use in SEFA; Ecoinvent v2.2
Sodium Hydroxide (Caustic Soda), 25%	0.545	kg CO2e/kg	Production emissions, Chlor-alkali, membrane cell technique	EPA, 2016. LCI data - Treatment Chemicals, Construction Materials, Transportation, onsite equipment and othe processes for use in SEFA; Ecoinvent v2.2
Methanol, 100%	1.4	kg CO2e/kg	Production emissions	SimaProv7.10, BLE, 2010, Guideline Sustainable Biomass Production
Methanol, 100%	0.67	MT CO2e/MT feedstock	Production Emissions, Steam reforming of natural gas, Table 3.12	2006. IPCC Guidelines for National Greenhouse Gas Inventories, Chapter 3 Chemical Industry Emissions
Citric Acid, Anhydrous	0.429	kg CO2e/kg citric acid	Production emissions	<a href="https://www.canada.ca/en/environment-climate-change/services/climate-change/pricing-pollution-how-it-will-work/output-based-pricing-system/complete-text-for-proposal-regulations.html">https://www.canada.ca/en/environment-climate-change/services/climate-change/pricing-pollution-how-it-will-work/output-based-pricing-system/complete-text-for-proposal-regulations.html</a>
Citric Acid, Anhydrous	0.96	kg Co2e/kg	Production emissions	ISCC 2015 GHG emissions; Biograce v 4d, 2014
Citric Acid, 50%	0.41	kg Co2e/kg	Production emissions, Microbial	Nica, Anca & Woinaroschy, Alexandru. (2010). Environmental assessment of citric acid production. UPB Scientific Bulletin, Series B: Chemistry and Materials Science. 72.
Sodium Hypochlorite (12.5%)	0.636		Production emissions	He, C., Liu, Z. & Hodgins, M., 2013.

King County Electricity Profile	MT/MWh	g CO2e/kWh	MT/MMBtu	\$/KW
West Point	0.0089	8.90	0.003	0.0781
South Plant	0.0000	0.00	0.132	0.0758
Brightwater	0.0065	6.50	0.002	0.0781

Other Assumptions	Value	Units	Notes	Source/Reference
Sodium Hydroxide (25%) Specific Gravity	1.278			MSDS
Methanol Specific Gravity	0.7915			MSDS
Citric Acid Specific Gravity	1.24			Suez Proposal, 2019
Sodium Hypochlorite (12.5%) Specific Gravity	1.168			Suez Proposal, 2019
<b>Trucking and Transportation</b>				
Liquid transportation Capacity	6,800	Gallons		Assumption
Class 8 Tanker Truck	2.04	kg CO2e/ mile		USEPA, (2004)
Methanol Transportation, Roundtrip	100	miles		Assumption
Citric Acid Transportation, Roundtrip	100	miles		Assumption
Sodium Hydroxide Transportation, Roundtrip	100	miles		Assumption
Sodium Hypochlorite Transportation, Roundtrip	100	miles		Assumption

Configuration	N2O Emission Factors	% inf TKN emitted as N2O	% inf TN emitted as N2O	% TN Removed Emitted as N2O	IPCC Emission Factor Table 6A.5	Emission Factor Used
					% inf TN emitted as N2O	% TN Removed Emitted as N2O
BNR (IPCC, 2014)	7.0 <sup>a</sup> (Treatment), 0.005 <sup>d</sup>	-	0.764, 1.44, 1.3 <sup>7</sup> , 0.28 - 11.84 <sup>8</sup>	-	-	-
AO	-	-	-	0.128 <sup>11</sup> , 0.493 <sup>11</sup> , 0.126 <sup>12</sup>	-	0.127
BNR	-	-	0-14.6 <sup>6</sup>	-	1.6	1.6
Four-Stage Bardenpho (4SMB)	33±16 <sup>1,a</sup> , 92±47 <sup>1,a</sup>	0.60±0.29 <sup>1</sup> , 1.6±0.83 <sup>1</sup>	0.66±0.32 <sup>1</sup> , 2.9±0.15 <sup>1</sup> , 0.36 <sup>1</sup>	0.66±0.32 <sup>1</sup> , 2.9±1.5 <sup>1</sup>	0.36	0.66
MLE	6.8±3.5 <sup>1,a</sup> , 5.4±2.0 <sup>1,a</sup>	0.44 <sup>9</sup> , 0.07 <sup>9</sup>	0.07±0.04 <sup>1</sup> , 0.06±0.02 <sup>1</sup> , 0.008 <sup>9</sup> , 0.001 <sup>2</sup>	0.09±0.05 <sup>1</sup> , 0.07±0.03 <sup>1</sup>	0.07, 0.06	0.08
MBR	No Clear Literature			-	-	Assumed upstream treatment EF
Tertiary Denit Fixed Film Filters	-	-	-	1.28 <sup>13,e</sup> , 0.22 <sup>13,e</sup>	-	0.75
Sidestream Anammox	-	-	0.75 <sup>3</sup> , 1.7 <sup>4</sup> , 0.9-1.3 <sup>5</sup> , 2-9 <sup>6</sup> , 0.51 <sup>10</sup>	-	-	0.9867
Sidestream Bioaugmentation	No Clear Literature			-	-	-

**Reference Notation**

- Sources**
- 1 Ahn et al., 2009
  - 2 Tumendelger et al., 2019
  - 3 Christenson et al., 2013
  - 4 Weissenbacher et al., 2012
  - 5 Strenstrom et al., 2017
  - 6 Witcht et Beier, 1995
  - 7 Weissenbacher et al., 2010
  - 8 Foley et al., 2010
  - 9 Chandran, 2011
  - 10 Baresel et al., 2016
  - 11 Masuda et al., 2018
  - 12 Rodriguez-Caballero et al., 2014
  - 13 Bollon et al., 2016

**Reference Notation**

- Units**
- a (g N2O/PE/Yr)
  - b (g N2O/g reduced N)
  - c (g N2O/g inf N)
  - d (g N2O-N/g eff N)
  - e (g N2O/g NO3 removed)
  - u (g-C/d)

## References

- Ahn, J. H., Kim, S., Park, H., Rahm, B., Pagilla, K., & Chandran, K. (2010). N<sub>2</sub>O emissions from activated sludge processes, 2008-2009: Results of a national monitoring survey in the united states. *Environmental Science and Technology*, 44(12), 4505–4511. <https://doi.org/10.1021/es903845y>
- Baresel, C., Andersson, S., Yang, J., & Andersen, M. H. (2016). Comparison of nitrous oxide (N<sub>2</sub>O) emissions calculations at a Swedish wastewater treatment plant based on water concentrations versus off-gas concentrations. *Advances in Climate Change Research*, 7(3), 185–191. <https://doi.org/10.1016/j.accre.2016.09.001>
- Bollon, J., Filali, A., Fayolle, Y., Guerin, S., Rocher, V., & Gillot, S. (2016). N<sub>2</sub>O emissions from full-scale nitrifying biofilters. *Water Research*, 102, 41–51. <https://doi.org/10.1016/j.watres.2016.05.091>
- Chandran, K. (2011). *Protocol for the measurement of nitrous oxide fluxes from biological wastewater treatment plants*. *Methods in Enzymology* (1st ed., Vol. 486). Elsevier Inc. <https://doi.org/10.1016/B978-0-12-381294-0.00016-X>
- Christensson, M., Ekström, S., Andersson Chan, A. Le Vaillant, E., and Lemaire, R. (2013) “Experience from startups of the first ANITA Mox plants,” *Water Sci. Technol.*, 67, 12, 2677- 2684
- Foley, J., de Haas, D., Yuan, Z., & Lant, P. (2010). Nitrous oxide generation in full-scale biological nutrient removal wastewater treatment plants. *Water Research*, 44(3), 831–844. <https://doi.org/10.1016/j.watres.2009.10.033>
- Masuda, S., Sano, I., Hojo, T., Li, Y. Y., & Nishimura, O. (2018). The comparison of greenhouse gas emissions in sewage treatment plants with different treatment processes. *Chemosphere*, 193, 581–590. <https://doi.org/10.1016/j.chemosphere.2017.11.018>
- Rodriguez-Caballero, A., Aymerich, I., Poch, M., & Pijuan, M. (2014). Evaluation of process conditions triggering emissions of green-house gases from a biological wastewater treatment system. *Science of the Total Environment*, 493, 384–391. <https://doi.org/10.1016/j.scitotenv.2014.06.015>
- Stenström, F. (2017). *Risk of nitrous oxide emissions and potential of bioaugmentation when treating digester supernatant via nitrification-denitrification*.
- Tumendelger, A., Alshboul, Z., & Lorke, A. (2019). Methane and nitrous oxide emission from different treatment units of municipal wastewater treatment plants in Southwest Germany. *PLoS ONE*, 14(1), e0209763. <https://doi.org/10.1371/journal.pone.0209763>



Weissenbacher, N., Takacs, I., Murthy, S., Fuerhacker, M., & Wett, B. (2010). Gaseous Nitrogen and Carbon Emissions from a Full-Scale Deammonification Plant. *Water Environment Research*, 82(2), 169–175.

<https://doi.org/10.2175/106143009x447867>

Wicht, H. (1996). A model for predicting nitrous oxide production during denitrification in activated sludge. In *Water Science and Technology* (Vol. 34, pp. 99–106). Pergamon Press Inc. [https://doi.org/10.1016/0273-1223\(96\)00634-8](https://doi.org/10.1016/0273-1223(96)00634-8)

## **Attachment C: Basis of Capital Cost Estimates of Alternatives**

---



**South Plant Nitrogen Removal Alternatives Cost Estimate Summary - AACEI Class 5**

Alternative	1A	2A	2B	3A	3B	4A	4C	4D	4E
<b>Scenario modifications or effluent limits/targets</b>	Sidestream treatment, nitrification/denitrification during summer using existing infrastructure	Seasonal "N" Removal, Effluent Limit of 8mg/L		Year-Round "N" Removal, 8mg/L Equivalent		Year-Round "N" Removal, Effluent Limit of 3mg/L			
<b>Alternative Description</b>	Existing mainstream + sidestream anammox	MLE + Tertiary Denitrifying Fixed-Film	MLE + Sidestream Anammox	4SMB + Sidestream Anammox	4SMB + Bioaugmentation	4SMB + Sidestream Anammox	MLE + Tertiary Denitrifying Fixed-Film	Existing Mainstream + Tertiary Denitrifying Fixed-Film)	4SMB/MBR + Sidestream Anammox
<b>DIRECT: SUBTOTAL CONSTRUCTION COSTS</b>									
Item No.	Item Description	Item Cost							
1	A - Primary Effluent								\$ 40,086,000
2	B - Aeration Basins		\$ 42,740,000	\$ 61,696,000	\$ 144,669,000	\$ 125,267,000	\$ 251,608,000	\$ 120,771,000	\$ 99,533,000
3	C - Membrane Basins								\$ 451,074,000
4	D - Internal Mixed Liquor Return (IMLR) Pumping		\$ 17,436,000	\$ 20,264,000	\$ 18,845,000	\$ 17,195,000	\$ 25,444,000	\$ 28,751,000	\$ 22,930,000
6	F - Sidestream Anammox	\$ 29,573,000		\$ 29,573,000	\$ 29,573,000		\$ 29,573,000		\$ 29,573,000
7	G - Supplemental Methanol System		\$ 3,483,000	\$ 3,483,000	\$ 1,742,000	\$ 1,742,000	\$ 3,483,000	\$ 6,966,000	\$ 6,966,000
8	H - Supplemental Alkalinity System	\$ 1,206,000	\$ 2,679,000	\$ 2,009,000	\$ 2,679,000	\$ 2,679,000	\$ 1,206,000	\$ 4,019,000	\$ 4,019,000
9	I - Aeration Blowers		\$ 42,437,000	\$ 39,350,000	\$ 41,907,000	\$ 46,388,000	\$ 41,362,000	\$ 47,067,000	\$ 35,935,000
10	J - Aeration Basin Mixers for Anoxic Zones		\$ 3,155,000	\$ 3,652,000	\$ 9,334,000	\$ 8,534,000	\$ 12,612,000	\$ 5,120,000	\$ 8,076,000
11	K - Sidestream Bioaugmentation					\$ 9,662,000			
12	L - Tertiary Pumps		\$ 14,226,000					\$ 21,372,000	\$ 26,173,000
13	M - Tertiary Fixed-Film System		\$ 70,894,000					\$ 117,064,000	\$ 356,416,000
16	P - Miscellaneous Scope	\$ 274,000	\$ 31,962,000	\$ 7,247,000	\$ 11,377,000	\$ 11,395,000	\$ 11,776,000	\$ 30,194,000	\$ 23,373,000
	<b>Subtotal Construction Costs</b>	\$ 31,053,000	\$ 229,012,000	\$ 167,274,000	\$ 260,126,000	\$ 222,862,000	\$ 377,064,000	\$ 381,324,000	\$ 416,947,000
	Allowance for Indeterminates (Design Allowance)	\$ 7,763,250	\$ 57,253,000	\$ 41,818,500	\$ 65,031,500	\$ 55,715,500	\$ 94,266,000	\$ 95,331,000	\$ 104,236,750
	Street Use Permit	\$ -	\$ -	\$ -	\$ -	\$ -	\$ -	\$ -	\$ -
	<b>ESTIMATED PROBABLE COST OF CONSTRUCTION BID</b>	\$ 38,816,250	\$ 286,265,000	\$ 209,092,500	\$ 325,157,500	\$ 278,577,500	\$ 471,330,000	\$ 476,655,000	\$ 521,183,750
<b>DIRECT: SUBTOTAL ADDITIONAL CONSTRUCTION COSTS</b>									
	Mitigation Construction Contracts	\$ -	\$ -	\$ -	\$ -	\$ -	\$ -	\$ -	\$ -
	Construction Change Order Allowance	\$ 3,881,625	\$ 28,626,500	\$ 20,909,250	\$ 32,515,750	\$ 27,857,750	\$ 47,133,000	\$ 47,665,500	\$ 52,118,375
	Material Pricing Uncertainty Allowance	\$ -	\$ -	\$ -	\$ -	\$ -	\$ -	\$ -	\$ -
	<b>Subtotal Primary Construction Amount</b>	\$ 42,697,875	\$ 314,891,500	\$ 230,001,750	\$ 357,673,250	\$ 306,435,250	\$ 518,463,000	\$ 524,320,500	\$ 573,302,125
	Construction Sales Tax	\$ 4,312,485	\$ 31,804,042	\$ 23,230,177	\$ 36,124,998	\$ 30,949,960	\$ 52,364,763	\$ 52,956,371	\$ 57,903,515
	Owner Furnished Equipment	\$ -	\$ -	\$ -	\$ -	\$ -	\$ -	\$ -	\$ -
	Outside Agency Construction	\$ -	\$ -	\$ -	\$ -	\$ -	\$ -	\$ -	\$ -
	<b>Subtotal KC Contribution to Construction</b>	\$ 47,010,360	\$ 346,695,542	\$ 253,231,927	\$ 393,798,248	\$ 337,385,210	\$ 570,827,763	\$ 577,276,871	\$ 631,205,640
<b>DIRECT: SUBTOTAL OTHER CAPITAL CHARGES</b>									
	KC/WTD Direct Implementation	\$ -	\$ -	\$ -	\$ -	\$ -	\$ -	\$ -	\$ -
	Misc. Capital Costs	\$ 85,396	\$ 629,783	\$ 460,004	\$ 715,347	\$ 612,871	\$ 1,036,926	\$ 1,048,641	\$ 1,146,604
	<b>TOTAL DIRECT CONSTRUCTION COSTS</b>	\$ 47,096,000	\$ 347,325,000	\$ 253,692,000	\$ 394,514,000	\$ 337,998,000	\$ 571,865,000	\$ 578,326,000	\$ 632,352,000
<b>INDIRECT: NON-CONSTRUCTION COSTS</b>									
	Design and Construction Consulting	\$ 11,569,918	\$ 77,552,459	\$ 59,857,727	\$ 86,142,183	\$ 75,831,191	\$ 117,001,907	\$ 118,091,236	\$ 127,120,066
	Other Consulting Services	\$ -	\$ -	\$ -	\$ -	\$ -	\$ -	\$ -	\$ -
	Permitting & Other Agency Support	\$ 213,489	\$ 2,771,045	\$ 2,024,015	\$ 3,147,525	\$ 2,696,630	\$ 4,562,474	\$ 4,614,020	\$ 5,045,059
	Right-of-Way	\$ -	\$ -	\$ -	\$ -	\$ -	\$ -	\$ -	\$ -
	Misc. Service & Materials	\$ 768,562	\$ 5,668,047	\$ 4,140,032	\$ 6,438,119	\$ 5,515,835	\$ 9,332,334	\$ 9,437,769	\$ 10,319,438
	Non-WTD Support	\$ 277,536	\$ 2,046,795	\$ 1,495,011	\$ 2,324,876	\$ 1,991,829	\$ 3,370,010	\$ 3,408,083	\$ 3,726,464
	WTD Staff Labor	\$ 6,766,033	\$ 42,398,669	\$ 31,885,490	\$ 48,892,448	\$ 42,505,898	\$ 73,722,476	\$ 74,485,937	\$ 80,847,388
	<b>Subtotal Non-Construction Costs</b>	\$ 19,595,539	\$ 130,437,014	\$ 99,402,276	\$ 146,945,150	\$ 128,541,382	\$ 207,989,201	\$ 210,037,045	\$ 227,058,415
	Project Contingency Initiatives	\$ 20,135,419	\$ 144,243,665	\$ 106,604,617	\$ 163,474,529	\$ 140,855,365	\$ 235,449,429	\$ 238,018,311	\$ 259,468,692
		\$ 779,987	\$ 5,654,817	\$ 4,157,207	\$ 6,415,204	\$ 5,513,406	\$ 9,266,527	\$ 9,369,255	\$ 10,227,623
	<b>TOTAL INDIRECT NON-CONSTRUCTION COSTS</b>	\$ 40,511,000	\$ 280,335,000	\$ 210,164,000	\$ 316,835,000	\$ 274,910,000	\$ 452,705,000	\$ 457,425,000	\$ 496,755,000
	<b>TOTAL PROJECT COST</b>	\$ 87,610,000	\$ 627,660,000	\$ 463,860,000	\$ 711,350,000	\$ 612,910,000	\$ 1,024,570,000	\$ 1,035,750,000	\$ 1,129,110,000
	<b>TOTAL PROJECT COST - Low End (-50%)</b>	\$ 43,810,000	\$ 313,830,000	\$ 231,930,000	\$ 355,680,000	\$ 306,460,000	\$ 512,290,000	\$ 517,880,000	\$ 564,560,000
	<b>TOTAL PROJECT COST - High End (+300%)</b>	\$ 350,440,000	\$ 2,510,640,000	\$ 1,855,440,000	\$ 2,845,400,000	\$ 2,451,640,000	\$ 4,098,280,000	\$ 4,143,000,000	\$ 4,516,440,000



# King County

Department of Natural Resources and Parks  
Wastewater Treatment Division

## Project Planning and Delivery Section

### BASIS OF ESTIMATE

---

Project Name	<b>South Treatment Plant Nitrogen Removal - Alternative 1A</b>
Project Number	
Date Prepared	March 24, 2020
Requested by	Tiffany Knapp, King County WTD
Prepared by	Douglas W. Leo, CCP, CEP, FRICS, FAACE Hon. Life, (VMS, Inc.)
Estimate Classification	WTD Class 5
Estimate Purpose	King County Class 5 Concept Screening
Estimate ID (Version)	6
Project Manager	Eron Jacobson, King County WTD
Project Control Engineer	
Cc or Distribution List	

*Note that the accuracy of the associated cost estimate is dependent upon the various underlying assumptions, inclusions, and exclusions described herein. Actual project costs may differ and can be significantly affected by factors such as changes in the external environment, the manner in which the project is executed and controlled, and other factors that may impact the estimate basis or otherwise affect the project. Estimate accuracy ranges are only assessments based upon the cost estimating methods and data employed in preparing the estimate and are not a guarantee of actual project costs.*

## BASIS OF ESTIMATE

Project Name	<b>South Treatment Plant Nitrogen Removal - Alternative 1A</b>		
Project Number:		Date:	March 24, 2020

### 1.0 Purpose

---

The purpose of this estimate is to provide cost information to support King County's South Treatment Plant (STP) Flows and Loading Alternative Evaluation for the Nitrogen Removal Project. A series of alternatives have been developed for project evaluation to determine the best engineering and project cost solution.

This estimate was prepared to establish a King County Wastewater Treatment Division (WTD) pre-Class 5 conceptual cost estimate to provide order of magnitude cost to support WTD's capital project identification and budgeting process for Total Project Costs. The WTD pre-Class 5 estimate provides similar documentation to that of an AACE International Class 5 estimate. The range of anticipated project costs, per WTD estimating guidance, is -50% / +300%. The range of uncertainty is beyond that for a typical Class 5 estimate due to the scope being proximally defined with today's relative solutions and technologies to resolving the identified needs; when the projects move forward into capital delivery over the longer term, it is anticipated that many differences and changes may arise as the known and defined engineering solutions are developed.

Douglas Leo of Value Management Strategies, Inc. (VMS) prepared this Basis of Estimate in coordination with King County WTD, the Brown and Caldwell Engineers team, and the VMS estimating team after receiving scope information from WTD in October / November 2019 thru February 2020. This Basis of Estimate reflects VMS's best understanding of the estimating process for this project, as explained by King County WTD and Brown and Caldwell.

### 2.0 Project Scope Definition

---

This estimate includes all investigation, administration / owners' costs, engineering and design, purchases, fabrications, installations, process certifications, permitting, community impacts, and miscellaneous costs not specifically excluded elsewhere in this document.

Comprehensive Total Field Costs are generated from historical allowances, sources such as WTD estimating tools, historical costs, and RS Means / VMS estimating databases. All supporting indirect costs were generated from the WTD PRISM historical database. All costs included in the estimate reflect the best understanding of requirements as they existed at the time this estimate was prepared.

The scope of South Treatment Plant Flows and Loading Alternative 1A is to provide Sidestream treatment and nitrification and denitrification during summer using existing infrastructure. The scope was developed to a Conceptual Design level adequate to assess operations and maintenance issues, energy impacts, permitting and code compliance issues, constructability, estimated costs, and implementation schedule.

The Project Estimate was prepared utilizing the following Work Breakdown Structure (WBS) in order to provide clarity and transparency to the estimated costs. The scope as identified for the alternative is described below in accordance with the WBS. Details are based on the known and defined scope in the design documents provided. See section 3.0 for a detailed list of Design Documents.

- A. Primary Effluent (PE)
  - *Not included in the scope for this alternative.*
- B. Aeration Basins
  - *Not included in the scope for this alternative.*
- C. Membrane Basins
  - *Not included in the scope for this alternative.*

## BASIS OF ESTIMATE

Project Name	<b>South Treatment Plant Nitrogen Removal - Alternative 1A</b>		
Project Number:		Date:	March 24, 2020

- D. Internal Mixed Liquor Return (IMLR) Pumping
  - *Not included in the scope for this alternative*
- E. Return Activated Sludge (RAS) Pump
  - *Not included in the scope for this alternative*
- F. Sidestream Anammox
  - Includes Sidestream Anammox – purchase / install
  - Pumps, Skimmer / Chain / Flight for Sedimentation Tank, Mixers
  - Centrate EQ Tank (110K gal.), Centrate Sedimentation Tank (192.3K gal.), Anammox Reactor Tanks (500K gal.)
- G. Supplemental Methanol System
  - *Not included in the scope for this alternative*
- H. Supplemental Alkalinity System
  - Supplemental Alkalinity System 90K gal. – purchase / install
- I. Aeration Blowers
  - *Not included in the scope for this alternative*
- J. Aeration Basin Mixers for Anoxic Zones
  - *Not included in the scope for this alternative*
- K. Sidestream Bioaugmentation
  - *Not included in the scope for this alternative*
- L. Tertiary Pumps
  - *Not included in the scope for this alternative*
- M. Tertiary Fixed Film System
  - *Not included in the scope for this alternative*
- N. Aeration / MBR Odor Control
  - *Not included in the scope for this alternative*
- O. Primary Clarifier / Aerated Grit Tank
  - *Not included in the scope for this alternative*
- P. Miscellaneous Scope
  - Centrate to Sidestream Anammox
  - Anammox Effluent to Thickener Overflow Piping

### 3.0 Design Basis

---

This is an AACE International Class 5 estimate with all required documentation. The estimate is based on engineering deliverables, scoping documentation, discussions with the project team, and all supporting information and documentation provided in October 2019 thru February 2020.

Engineering conceptual scope was provided in the following estimating deliverables. These are the most complete scoping documents that were available to the estimating provider.

Engineering and Estimating Deliverables provided include:

- Brown and Caldwell Markup, Existing aeration basins 1-4 retrofit assumptions for MLE (Alt 2A/2B/4C)

## BASIS OF ESTIMATE

Project Name	<b>South Treatment Plant Nitrogen Removal - Alternative 1A</b>		
Project Number:		Date:	March 24, 2020

- Membrane feed pump station wetwell assumptions, undated
- New aeration basin example sketch for MLE (Alt 2A/2B/4C)
- New aeration basin example sketch for 4SMB (Alt 3A/3B/4A)
- Tertiary Feed Pump Station Wetwell sketch, (Alt 2A) and (Alt 4C/4D)
- Brown and Caldwell Layout, STP Nitrogen Removal Study, 9ea. Alternative Marked Up Sketches, undated
- Anammox Cap Cost Assumptions STP, undated
- SP Nitrogen Removal Alt. – Cost Estimating Assumptions, undated
- Velloa, Biostyr HGL drawing package, dated: 02.01.19
- Brown and Caldwell, General Process Arch. Structural drawing package, dated: November 1996
- South Treatment Plant, plant map, dated: June 2016
- Brown and Caldwell, Mechanical, Electrical, Instrumentation drawing package, dated: November 1996
- Brown and Caldwell, General Process and Instrumentation drawing package, dated: October 1993
- Brown and Caldwell, Architectural and Structural drawing package, dated: October 1993
- Brown and Caldwell, Mechanical drawing package, dated: October, 1993
- Brown and Caldwell, General Process and Structural drawing package, dated: October, 1993
- Brown and Caldwell, Mechanical and Electrical drawing package, dated: October, 1993

### Equipment Quotes:

- Next Turbo Budget Quote, Aeration Blowers, dated: 10.25.2019
- Suez Budget Quote, MBR, dated: 10.21.2019
- Ovivo Budget Quote, Sidestream Anammox, dated: 09.17.2019
- Biostyr Budget Quote, Tertiary, dated: 10.17.2019

## 4.0 Planning Basis

---

The following planning basis assumptions were made for the project estimate:

- No project construction plan is in place at this time.
- The assumed execution strategy is a standard workweek with limited overtime.
- No unusual site conditions have been considered as part of this estimate.
- Adequate available power exists at the site.

## 5.0 Cost Basis

---

- All allied and indirect project costs (allowances for indeterminates, change order allowance, engineering, permitting, WTD staffing, etc.) have been estimated using WTD's PRISM cost model which is baselined to historical project costs.
- The estimate was performed based on drawings, sketches, and project information provided by King County and Brown and Caldwell Engineers.
- WTD is using a PRISM cost model dated January 26, 2017. All Allied and indirect project costs have been estimated using the new WTD PRISM cost model baselined to historical project costs.



## BASIS OF ESTIMATE

Project Name	<b>South Treatment Plant Nitrogen Removal - Alternative 1A</b>		
Project Number:		Date:	March 24, 2020

- Additional technical project complexity factors for WTD indirect project costs have been introduced and incorporated into project allied costs to allow for development of an additional WTD indirect cost allowance, based upon the unique characteristics of the project.
- Equipment factors were developed utilizing historical data which accounts for specific install of the identified equipment within a normal battery limit. Specific scope relative to this project was used in the equipment factor determination. Factors for each specific type of equipment reflect the different complexity of the installation. Engineering supplied equipment costs were multiplied by the factors in order to estimate direct construction cost for the purchase and install of the equipment.
- Estimated costs incorporate prevailing King County wage rates.
- All costs were estimated in 1<sup>st</sup> Quarter 2020 dollars.

### 6.0 Allowances

---

The level and types of allowances used in the estimate is as follows (common percentages for each alternative are shown and any estimate-specific differences are indicated):

- Sales Tax was included as 10.1% applied to the base construction cost, including the design and change order contingencies.
- A 25% Allowance for Indeterminates (AFI) is applied to the base construction cost. The AFI is an allowance that accounts for the cost of known but undefined requirements necessary for a complete and workable project. The AFI accounts for elements that are not explicitly shown in the project documents to be further defined as part of the design development and project delivery process. The AFI is carried at 25% at conceptual design, based on the WTD project delivery process.
- Allowance of 10% for potential construction change orders.
- Allowance of 0.2% of the primary construction amount for miscellaneous direct capital costs.
- Allowance of 0.5% of the primary construction amount for permitting and other agency support.
- Allowance of 1.8% of the primary construction amount for miscellaneous services and material.
- Allowance of 0.65% of the primary construction amount for Non-WTD Support.
- Allowance of 1.0% of the primary construction amount for art initiatives.
- Allowance of 0.5% of the total project cost for sustainability.
- Allowance for application of total project contingency (see *Contingency* section below).
- Allowance of 15.85% of the primary construction amount for Engineering Services.
- Allowance of 11.25% of the primary construction amount for Construction Management Support
- Allowance of 14.37% of the primary construction amount for WTD staff labor and burden.
- No Escalation has been included.
- Additional estimating allowances for WTD indirect costs of approximately \$2.08 million have been included in the Total Project Cost estimate by using a moderate degree of complexity rating for Construction Management, Operations Support, and Project Management. All other indirect costs

## BASIS OF ESTIMATE

Project Name	<b>South Treatment Plant Nitrogen Removal - Alternative 1A</b>		
Project Number:		Date:	March 24, 2020

were considered routine. Complexity factors were calibrated based on comments received from King County on March 4, 2020.

- An allowance of \$1.11 million for Design and Construction Consulting
- An allowance of \$0.95 million for WTD Staff Labor

### 7.0 Assumptions

---

Any other assumptions made by the estimator but not documented elsewhere in the estimate basis are included in this section.

- All costs included in the estimate reflect the best understanding of requirements as they existed at the time the estimates were prepared. Any modifications to the present scope and/or location of the project site may have substantial cost and schedule impacts.
- The engineering design will be performed by an external consultant engineer.
- Construction management will not be performed “in-house” by WTD. It will be performed by an external consultant construction manager.
- The project will generally align with the WTD PRISM cost model for Treatment projects.
- All work will always be performed utilizing safe work methods.
- Work will be sequenced to minimize standard process, service, and community interruptions. However, no costs are included to address sequencing necessary to keep the plant operational during construction.
- No costs are included for any new facilities that would be required, beyond the scope of this project to replace any lost capacity to the South Treatment Plant.
- It is assumed that the best improvement solution is included in the project scope(s).
- There will be some degree of productivity loss due to the site location. Some degree of productivity loss is included in the estimated costs. Any unusual site conditions are not accounted for in this estimate.
- Any additional work discovered during project implementation would need to be either a supplemental approval of added scope or be approved as an additional project.
- This project will be engineered to meet Washington State area seismic requirements.
- A degree of minimal cost rounding will occur during the normal estimating process.
- No allowance is included for Material Pricing Uncertainty.
- Power is readily available in the general area of this project. No new power sources are included in the scope of this project.
- It is assumed that some general material contamination is present. The estimate covers minimal cost of removal wherever the contamination is disturbed during construction. This cost is covered in productivity rates utilized in the estimate.

## BASIS OF ESTIMATE

Project Name	<b>South Treatment Plant Nitrogen Removal - Alternative 1A</b>		
Project Number:		Date:	March 24, 2020

### 8.0 Exclusions

---

All potential items of cost which might be associated with the project but for which no costs have been included are listed below:

- No asbestos removal costs are included.
- No estimated costs are included for any potential delays due to interferences.
- No costs are included for utility relocations.
- No costs are included for temporary construction easements.
- No costs are included for street use or street improvement permits.
- No costs are included for additional scope beyond that as detailed in the current scope of work.

### 9.0 Exceptions

---

This estimate is classified as a King County Wastewater Treatment Division Class 5 estimate based on an AACE International Class 5 estimate, with no exceptions per the King County WTD project process, for the scope as known at the time of the estimate preparation.

### 10.0 Risks (Threats and Opportunities)

---

At the time of estimate preparation, a formal risk analysis session had not been conducted. General potential risks are listed below.

- There is a risk that additional scope, technology advances or major deviation from the suggested project scope will adversely impact cost and schedule.
- Future unknown or changing site conditions present a risk around productivities, schedule, and costs.
- More stringent or completely new regulations, usage fees, permitting, or environmental impacts may result in risks that could adversely impact cost and schedule.
- Potential complex construction and constructability issues could arise during construction, resulting in major design / construction changes.
- The space constraints could significantly impact assumed productivities and crew sizes identified for the estimated concept, resulting in increased costs due to loss of production.
- The scheduled timing of project execution will greatly impact the bottom-line costs. There is risk related to labor availability and fluctuating commodity and equipment pricing in the timeframe between this early conceptual estimate and the actual execution of the project. Rising costs due to inflation, escalation and competing major worldwide projects pose the possibility of noticeable project cost and schedule increases.
- Weather conditions and emergency service interruptions present the possibility of negative schedule and cost impacts.
- Any possible coordination with other agencies could result in potential impacts on costs, schedule and Project Definition process.

## BASIS OF ESTIMATE

Project Name	<b>South Treatment Plant Nitrogen Removal - Alternative 1A</b>		
Project Number:		Date:	March 24, 2020

- There is a risk that stakeholders could oppose the proposed design or prefer a different approach or site to be selected, resulting in schedule delays and a higher cost alternative.

### 11.0 Contingency

---

Contingency is a cost element of the estimate used to cover uncertainties and unforeseeable elements of cost within the defined project scope. Contingency covers inadequacies in project scope definition, estimating methods, and estimating data. Contingency specifically excludes changes in project scope, and unforeseen major events such as earthquakes, prolonged labor strikes, etc.

A 30% Project Contingency was added to the base estimate of Total Project Costs (direct and indirect) as a result of the project estimating process and in accordance with the King County WTD project delivery process.

The estimating analysis resulted in a project contingency of approximately \$20.1 million (US\$).

The total project cost at a 50% confidence level (P50) is typically used for funding and baselining of a project at this stage and level of engineering and project development. The P50 confidence level suggests that there is a 50% cumulative probability of project cost under-run (or 50% probability of exceedance) at this dollar amount for the presently defined and known project scope.

### 12.0 Management Reserve

---

No allocation of costs was included in this estimate for Management Reserves.

Contingency is not intended to cover the costs for changes in project scope. If the project needs to provide an allowance for anticipated changes in scope or to cover the costs for items that may be required but have not yet been specifically identified as being included in the current project scope, then that amount of cost should be identified here.

### 13.0 Reconciliation

---

Reconciliation was not conducted at this time.

### 14.0 Benchmarking

---

All included Allied Costs as supplied by the PRISM historical database have been benchmarked against a similar portfolio of recently completed projects.

### 15.0 Estimate Quality Assurance Plan

---

No reviews of total project costs have been conducted outside the reviews conducted within Brown and Caldwell and VMS estimating team. It is anticipated that upon completion of this estimate, reviews will happen between the estimate provider and WTD.

### 16.0 Attachments

---

#### Attachment: Estimate Deliverables

Engineering and Estimating Deliverables provided include:

## BASIS OF ESTIMATE

Project Name	<b>South Treatment Plant Nitrogen Removal - Alternative 1A</b>		
Project Number:		Date:	March 24, 2020

- Brown and Caldwell Markup, Existing aeration basins 1-4 retrofit assumptions for MLE (Alt 2A/2B/4C)
- Membrane feed pump station wetwell assumptions, undated
- New aeration basin example sketch for MLE (Alt 2A/2B/4C)
- New aeration basin example sketch for 4SMB (Alt 3A/3B/4A)
- Tertiary Feed Pump Station Wetwell sketch, (Alt 2A) and (Alt 4C/4D)
- Brown and Caldwell Layout, STP Nitrogen Removal Study, 9ea. Alternative Marked Up Sketches, undated
- Anammox Cap Cost Assumptions STP, undated
- SP Nitrogen Removal Alt. – Cost Estimating Assumptions, undated
- Veloa, Biostyr HGL drawing package, dated: 02.01.19
- Brown and Caldwell, General Process Arch. Structural drawing package, dated: November 1996
- South Treatment Plant, plant map, dated: June 2016
- Brown and Caldwell, Mechanical, Electrical, Instrumentation drawing package, dated: November 1996
- Brown and Caldwell, General Process and Instrumentation drawing package, dated: October 1993
- Brown and Caldwell, Architectural and Structural drawing package, dated: October 1993
- Brown and Caldwell, Mechanical drawing package, dated: October, 1993
- Brown and Caldwell, General Process and Structural drawing package, dated: October, 1993
- Brown and Caldwell, Mechanical and Electrical drawing package, dated: October, 1993

### Equipment Quotes:

- Next Turbo Budget Quote, Aeration Blowers, dated: 10.25.2019
- Suez Budget Quote, MBR, dated: 10.21.2019
- Ovivo Budget Quote, Sidestream Anammox, dated: 09.17.2019
- Biostyr Budget Quote, Tertiary, dated: 10.17.2019



# King County

Department of Natural Resources and Parks  
Wastewater Treatment Division

## Project Planning and Delivery Section

### BASIS OF ESTIMATE

---

Project Name	<b>South Treatment Plant Nitrogen Removal - Alternative 2A</b>
Project Number	
Date Prepared	March 24, 2020
Requested by	Tiffany Knapp, King County WTD
Prepared by	Douglas W. Leo, CCP, CEP, FRICS, FAACE Hon. Life, (VMS, Inc.)
Estimate Classification	WTD Class 5
Estimate Purpose	King County Class 5 Concept Screening
Estimate ID (Version)	6
Project Manager	Eron Jacobson, King County WTD
Project Control Engineer	
Cc or Distribution List	

*Note that the accuracy of the associated cost estimate is dependent upon the various underlying assumptions, inclusions, and exclusions described herein. Actual project costs may differ and can be significantly affected by factors such as changes in the external environment, the manner in which the project is executed and controlled, and other factors that may impact the estimate basis or otherwise affect the project. Estimate accuracy ranges are only assessments based upon the cost estimating methods and data employed in preparing the estimate and are not a guarantee of actual project costs.*



## BASIS OF ESTIMATE

Project Name	<b>South Treatment Plant Nitrogen Removal - Alternative 2A</b>		
Project Number:		Date:	March 24, 2020

### 1.0 Purpose

---

The purpose of this estimate is to provide cost information to support King County's South Treatment Plant (STP) Flows and Loading Alternative Evaluation for the Nitrogen Removal Project. A series of alternatives have been developed for project evaluation to determine the best engineering and project cost solution.

This estimate was prepared to establish a King County Wastewater Treatment Division (WTD) pre-Class 5 conceptual cost estimate to provide order of magnitude cost to support WTD's capital project identification and budgeting process for Total Project Costs. The WTD pre-Class 5 estimate provides similar documentation to that of an AACE International Class 5 estimate. The range of anticipated project costs, per WTD estimating guidance, is -50% / +300%. The range of uncertainty is beyond that for a typical Class 5 estimate due to the scope being proximally defined with today's relative solutions and technologies to resolving the identified needs; when the projects move forward into capital delivery over the longer term, it is anticipated that many differences and changes may arise as the known and defined engineering solutions are developed.

Douglas Leo of Value Management Strategies, Inc. (VMS) prepared this Basis of Estimate in coordination with King County WTD, the Brown and Caldwell Engineers team, and the VMS estimating team after receiving scope information from WTD in October/November 2019 thru February 2020. This Basis of Estimate reflects VMS's best understanding of the estimating process for this project, as explained by King County WTD and Brown and Caldwell.

### 2.0 Project Scope Definition

---

This estimate includes all investigation, administration/owners' costs, engineering and design, purchases, fabrications, installations, process certifications, permitting, community impacts, and miscellaneous costs not specifically excluded elsewhere in this document.

Comprehensive Total Field Costs are generated from historical allowances, sources such as WTD estimating tools, historical costs, and RS Means/VMS estimating databases. All supporting indirect costs were generated from the WTD PRISM historical database. All costs included in the estimate reflect the best understanding of requirements as they existed at the time this estimate was prepared.

The scope of South Treatment Plant Flows and Loading Alternative 2A is to provide seasonal nitrogen removal (MLE and tertiary denitrifying fixed film), with an effluent total inorganic nitrogen (TIN) limit of 8mg/L. The scope was developed to a Conceptual Design level adequate to assess operations and maintenance issues, energy impacts, permitting and code compliance issues, constructability, estimated costs, and implementation schedule.

The Project Estimate was prepared utilizing the following Work Breakdown Structure (WBS) in order to provide clarity and transparency to the estimated costs. The scope as identified for the alternative is described below in accordance with the WBS. Details are based on the known and defined scope in the design documents provided. See section 3.0 for a detailed list of Design Documents.

- A. Primary Effluent (PE)
  - *Not included in the scope for this alternative.*
- B. Aeration Basins
  - New Aeration Basin Train and Baffle Walls
  - Interior Cell Walls in New Aeration Basin
  - New Storage Building

## BASIS OF ESTIMATE

Project Name	<b>South Treatment Plant Nitrogen Removal - Alternative 2A</b>		
Project Number:		Date:	March 24, 2020

- Demo Storage Building
- Relocate Construction Trailers
- C. Membrane Basins
  - *Not included in the scope for this alternative*
- D. Internal Mixed Liquor Return (IMLR) Pumping
  - IMLR Pumps – purchase / install
  - 36-inch CS Pipe per Aeration Basin
- E. Return Activated Sludge (RAS) Pump
  - *Not included in the scope for this alternative*
- F. Sidestream Anammox
  - *Not included in the scope for this alternative*
- G. Supplemental Methanol System
  - Supplemental Methanol System 30K gal. – purchase / install
- H. Supplemental Alkalinity System
  - Supplemental Alkalinity System 45K gal. – purchase / install
- I. Aeration Blowers
  - Aeration Blowers – purchase / install
  - Aeration Blower Diffusers
  - Demolition Allowance
- J. Aeration Basin Mixers for Anoxic Zones
  - Aeration Basin Mixers for Anoxic Zones
- K. Sidestream Bioaugmentation
  - *Not included in the scope for this alternative*
- L. Tertiary Pumps
  - Tertiary Pump – purchase / install
  - Tertiary Pumphouse / Electric Building
  - Tertiary Wet Well
  - Tertiary Wet Well Baffle Walls
- M. Tertiary Fixed Film System
  - Tertiary Fixed Film System – purchase / install
  - Tertiary Fixed film Basin
  - Tertiary Fixed Film Basin Interior Walls
- N. Aeration / MBR Odor Control
  - *Not included in the scope for this alternative*
- O. Primary Clarifier / Aerated Grit Tank
  - *Not included in the scope for this alternative*
- P. Miscellaneous Scope
  - Backwash Waste to North Primary Distribution System
  - ML to Secondary Clarifiers
  - RAS to Aeration Basins
  - PE to Aeration Basins
  - Tertiary Feed Pump Station By-pass / Overflow

## BASIS OF ESTIMATE

Project Name	<b>South Treatment Plant Nitrogen Removal - Alternative 2A</b>		
Project Number:		Date:	March 24, 2020

- Tertiary Effluent to New Chlorine Contact
- 48-inch Forced Mains from Tertiary Feed Pump Station to Fixed Film System
- Alkalinity to RAS Mix Box
- Methanol to Aeration Basin
- Allowance for Flood Control Dike

### 3.0 Design Basis

---

This is an AACE International Class 5 estimate with all required documentation. The estimate is based on engineering deliverables, scoping documentation, discussions with the project team, and all supporting information and documentation provided in October 2019 thru February 2020.

Engineering conceptual scope was provided in the following estimating deliverables. These are the most complete scoping documents that were available to the estimating provider.

Engineering and Estimating Deliverables provided include:

- Brown and Caldwell Markup, Existing aeration basins 1-4 retrofit assumptions for MLE (Alt 2A/2B/4C)
- Membrane feed pump station wetwell assumptions, undated
- New aeration basin example sketch for MLE (Alt 2A/2B/4C)
- New aeration basin example sketch for 4SMB (Alt 3A/3B/4A)
- Tertiary Feed Pump Station Wetwell sketch, (Alt 2A) and (Alt 4C/4D)
- Brown and Caldwell Layout, STP Nitrogen Removal Study, 9ea. Alternative Marked Up Sketches, undated
- Anammox Cap Cost Assumptions STP, undated
- SP Nitrogen Removal Alt. – Cost Estimating Assumptions, undated
- Velloa, Biostyr HGL drawing package, dated: 02.01.19
- Brown and Caldwell, General Process Arch. Structural drawing package, dated: November 1996
- South Treatment Plant, plant map, dated: June 2016
- Brown and Caldwell, Mechanical, Electrical, Instrumentation drawing package, dated: November 1996
- Brown and Caldwell, General Process and Instrumentation drawing package, dated: October 1993
- Brown and Caldwell, Architectural and Structural drawing package, dated: October 1993
- Brown and Caldwell, Mechanical drawing package, dated: October, 1993
- Brown and Caldwell, General Process and Structural drawing package, dated: October, 1993
- Brown and Caldwell, Mechanical and Electrical drawing package, dated: October, 1993

Equipment Quotes:

- Next Turbo Budget Quote, Aeration Blowers, dated: 10.25.2019
- Suez Budget Quote, MBR, dated: 10.21.2019
- Ovivo Budget Quote, Sidestream Anammox, dated: 09.17.2019
- Biostyr Budget Quote, Tertiary, dated: 10.17.2019

## **BASIS OF ESTIMATE**

Project Name	<b>South Treatment Plant Nitrogen Removal - Alternative 2A</b>		
Project Number:		Date:	March 24, 2020

### **4.0 Planning Basis**

---

The following planning basis assumptions were made for the project estimate:

- No project construction plan is in place at this time.
- The assumed execution strategy is a standard workweek with limited overtime.
- No unusual site conditions have been considered as part of this estimate.
- Adequate available power exists at the site.

### **5.0 Cost Basis**

---

- All allied and indirect project costs (allowances for indeterminates, change order allowance, engineering, permitting, WTD staffing, etc.) have been estimated using WTD's PRISM cost model which is baselined to historical project costs.
- The estimate was performed based on drawings, sketches, and project information provided by King County and Brown and Caldwell Engineers.
- WTD is using a PRISM cost model dated January 26, 2017. All Allied and indirect project costs have been estimated using the new WTD PRISM cost model baselined to historical project costs.
- Additional technical project complexity factors for WTD indirect project costs have been introduced and incorporated into project allied costs to allow for development of an additional WTD indirect cost allowance, based upon the unique characteristics of the project.
- Equipment factors were developed utilizing historical data which accounts for specific install of the identified equipment within a normal battery limit. Specific scope relative to this project was used in the equipment factor determination. Factors for each specific type of equipment reflect the different complexity of the installation. Engineering supplied equipment costs were multiplied by the factors in order to estimate direct construction cost for the purchase and install of the equipment.
- Estimated costs incorporate prevailing King County wage rates.
- All costs were estimated in 1<sup>st</sup> Quarter 2020 dollars.

### **6.0 Allowances**

---

The level and types of allowances used in the estimate is as follows (common percentages for each alternative are shown and any estimate-specific differences are indicated):

- Sales Tax was included as 10.1% applied to the base construction cost, including the design and change order contingencies.
- A 25% Allowance for Indeterminates (AFI) is applied to the base construction cost. The AFI is an allowance that accounts for the cost of known but undefined requirements necessary for a complete and workable project. The AFI accounts for elements that are not explicitly shown in the project documents to be further defined as part of the design development and project delivery process. The AFI is carried at 25% at conceptual design, based on the WTD project delivery process.

## BASIS OF ESTIMATE

Project Name	<b>South Treatment Plant Nitrogen Removal - Alternative 2A</b>		
Project Number:		Date:	March 24, 2020

- Allowance of 10% for potential construction change orders.
- Allowance of 0.2% of the primary construction amount for miscellaneous direct capital costs.
- Allowance of 0.88% of the primary construction amount for permitting and other agency support.
- Allowance of 1.8% of the primary construction amount for miscellaneous services and material.
- Allowance of 0.65% of the primary construction amount for Non-WTD Support.
- Allowance of 1.0% of the primary construction amount for art initiatives.
- Allowance of 0.5% of the total project cost for sustainability.
- Allowance for application of total project contingency (see *Contingency* section below).
- Allowance of 17.34% of the primary construction amount for Engineering Services.
- Allowance of 7.29% of the primary construction amount for Construction Management Support
- Allowance of 12.21% of the primary construction amount for WTD staff labor and burden.
- No Escalation has been included.
- Additional estimating allowances for WTD indirect costs of approximately \$31.5 million have been included in the Total Project Cost estimate by using a moderate degree of complexity rating for Design Engineering, Construction Management, Permitting & Licenses, Operations Support, Community Relations and Project Management. All other indirect costs were considered routine. Complexity factors were calibrated based on comments received from King County on March 4, 2020.
  - An allowance of \$23.5 million for Design and Construction Consulting
  - An allowance of \$1.20 million for Permitting & Other Agency Support
  - An allowance of \$6.79 million for WTD Staff Labor

## 7.0 Assumptions

---

Any other assumptions made by the estimator but not documented elsewhere in the estimate basis are included in this section.

- All costs included in the estimate reflect the best understanding of requirements as they existed at the time the estimates were prepared. Any modifications to the present scope and/or location of the project site may have substantial cost and schedule impacts.
- The engineering design will be performed by an external consultant engineer.
- Construction management will not be performed “in-house” by WTD. It will be performed by an external consultant construction manager.
- The project will generally align with the WTD PRISM cost model for Treatment projects.
- All work will always be performed utilizing safe work methods.
- Work will be sequenced to minimize standard process, service, and community interruptions. However, no costs are included to address sequencing necessary to keep the plant operational during construction.

## **BASIS OF ESTIMATE**

Project Name	<b>South Treatment Plant Nitrogen Removal - Alternative 2A</b>		
Project Number:		Date:	March 24, 2020

- No costs are included for any new facilities that would be required, beyond the scope of this project to replace any lost capacity to the South Treatment Plant.
- It is assumed that the best improvement solution is included in the project scope(s).
- There will be some degree of productivity loss due to the site location. Some degree of productivity loss is included in the estimated costs. Any unusual site conditions are not accounted for in this estimate.
- Any additional work discovered during project implementation would need to be either a supplemental approval of added scope or be approved as an additional project.
- This project will be engineered to meet Washington State area seismic requirements.
- A degree of minimal cost rounding will occur during the normal estimating process.
- No allowance is included for Material Pricing Uncertainty.
- Power is not readily available in the general area of this project. New power sources are included in the scope of this project.
- It is assumed that some general material contamination is present. The estimate covers minimal cost of removal wherever the contamination is disturbed during construction. This cost is covered in productivity rates utilized in the estimate.

### **8.0 Exclusions**

---

All potential items of cost which might be associated with the project but for which no costs have been included are listed below:

- No asbestos removal costs are included.
- No estimated costs are included for any potential delays due to interferences.
- No costs are included for utility relocations.
- No costs are included for temporary construction easements.
- No costs are included for street use or street improvement permits.
- No costs are included for additional scope beyond that as detailed in the current scope of work.

### **9.0 Exceptions**

---

This estimate is classified as a King County Wastewater Treatment Division Class 5 estimate based on an AACE International Class 5 estimate, with no exceptions per the King County WTD project process, for the scope as known at the time of the estimate preparation.

### **10.0 Risks (Threats and Opportunities)**

---

At the time of estimate preparation, a formal risk analysis session had not been conducted. General potential risks are listed below.

- There is a risk that additional scope, technology advances or major deviation from the suggested project scope will adversely impact cost and schedule.



## BASIS OF ESTIMATE

Project Name	<b>South Treatment Plant Nitrogen Removal - Alternative 2A</b>		
Project Number:		Date:	March 24, 2020

- Future unknown or changing site conditions present a risk around productivities, schedule, and costs.
- More stringent or completely new regulations, usage fees, permitting, or environmental impacts may result in risks that could adversely impact cost and schedule.
- Potential complex construction and constructability issues could arise during construction, resulting in major design / construction changes.
- The space constraints could significantly impact assumed productivities and crew sizes identified for the estimated concept, resulting in increased costs due to loss of production.
- The scheduled timing of project execution will greatly impact the bottom-line costs. There is risk related to labor availability and fluctuating commodity and equipment pricing in the timeframe between this early conceptual estimate and the actual execution of the project. Rising costs due to inflation, escalation and competing major worldwide projects pose the possibility of noticeable project cost and schedule increases.
- Weather conditions and emergency service interruptions present the possibility of negative schedule and cost impacts.
- Any possible coordination with other agencies could result in potential impacts on costs, schedule and Project Definition process.
- There is a risk that stakeholders could oppose the proposed design or prefer a different approach or site to be selected, resulting in schedule delays and a higher cost alternative.

### 11.0 Contingency

---

Contingency is a cost element of the estimate used to cover uncertainties and unforeseeable elements of cost within the defined project scope. Contingency covers inadequacies in project scope definition, estimating methods, and estimating data. Contingency specifically excludes changes in project scope, and unforeseen major events such as earthquakes, prolonged labor strikes, etc.

A 30% Project Contingency was added to the base estimate of Total Project Costs (direct and indirect) as a result of the project estimating process and in accordance with the King County WTD project delivery process.

The estimating analysis resulted in a project contingency of approximately \$144.24 million (US\$).

The total project cost at a 50% confidence level (P50) is typically used for funding and baselining of a project at this stage and level of engineering and project development. The P50 confidence level suggests that there is a 50% cumulative probability of project cost under-run (or 50% probability of exceedance) at this dollar amount for the presently defined and known project scope.

### 12.0 Management Reserve

---

No allocation of costs was included in this estimate for Management Reserves.

Contingency is not intended to cover the costs for changes in project scope. If the project needs to provide an allowance for anticipated changes in scope or to cover the costs for items that may be required but have not yet been specifically identified as being included in the current project scope, then that amount of cost should be identified here.

## **BASIS OF ESTIMATE**

Project Name	<b>South Treatment Plant Nitrogen Removal - Alternative 2A</b>		
Project Number:		Date:	March 24, 2020

### **13.0 Reconciliation**

---

Reconciliation was not conducted at this time.

### **14.0 Benchmarking**

---

All included Allied Costs as supplied by the PRISM historical database have been benchmarked against a similar portfolio of recently completed projects.

### **15.0 Estimate Quality Assurance Plan**

---

No reviews of total project costs have been conducted outside the reviews conducted within Brown and Caldwell and VMS estimating team. It is anticipated that upon completion of this estimate, reviews will happen between the estimate provider and WTD.

### **16.0 Attachments**

---

#### **Attachment: Estimate Deliverables**

Engineering and Estimating Deliverables provided include:

- Brown and Caldwell Markup, Existing aeration basins 1-4 retrofit assumptions for MLE (Alt 2A/2B/4C)
- Membrane feed pump station wetwell assumptions, undated
- New aeration basin example sketch for MLE (Alt 2A/2B/4C)
- New aeration basin example sketch for 4SMB (Alt 3A/3B/4A)
- Tertiary Feed Pump Station Wetwell sketch, (Alt 2A) and (Alt 4C/4D)
- Brown and Caldwell Layout, STP Nitrogen Removal Study, 9ea. Alternative Marked Up Sketches, undated
- Anammox Cap Cost Assumptions STP, undated
- SP Nitrogen Removal Alt. – Cost Estimating Assumptions, undated
- Velloa, Biostyr HGL drawing package, dated: 02.01.19
- Brown and Caldwell, General Process Arch. Structural drawing package, dated: November 1996
- South Treatment Plant, plant map, dated: June 2016
- Brown and Caldwell, Mechanical, Electrical, Instrumentation drawing package, dated: November 1996
- Brown and Caldwell, General Process and Instrumentation drawing package, dated: October 1993
- Brown and Caldwell, Architectural and Structural drawing package, dated: October 1993
- Brown and Caldwell, Mechanical drawing package, dated: October, 1993
- Brown and Caldwell, General Process and Structural drawing package, dated: October, 1993
- Brown and Caldwell, Mechanical and Electrical drawing package, dated: October, 1993

Equipment Quotes:

- Next Turbo Budget Quote, Aeration Blowers, dated: 10.25.2019
- Suez Budget Quote, MBR, dated: 10.21.2019
- Ovivo Budget Quote, Sidestream Anammox, dated: 09.17.2019
- Biostyr Budget Quote, Tertiary, dated: 10.17.2019



# King County

Department of Natural Resources and Parks  
Wastewater Treatment Division

## Project Planning and Delivery Section

### BASIS OF ESTIMATE

---

Project Name	<b>South Treatment Plant Nitrogen Removal - Alternative 2B</b>
Project Number	
Date Prepared	March 24, 2020
Requested by	Tiffany Knapp, King County WTD
Prepared by	Douglas W. Leo, CCP, CEP, FRICS, FAACE Hon. Life, (VMS, Inc.)
Estimate Classification	WTD Class 5
Estimate Purpose	King County Class 5 Concept Screening
Estimate ID (Version)	6
Project Manager	Eron Jacobson, King County WTD
Project Control Engineer	
Cc or Distribution List	

*Note that the accuracy of the associated cost estimate is dependent upon the various underlying assumptions, inclusions, and exclusions described herein. Actual project costs may differ and can be significantly affected by factors such as changes in the external environment, the manner in which the project is executed and controlled, and other factors that may impact the estimate basis or otherwise affect the project. Estimate accuracy ranges are only assessments based upon the cost estimating methods and data employed in preparing the estimate and are not a guarantee of actual project costs.*

## BASIS OF ESTIMATE

Project Name	<b>South Treatment Plant Nitrogen Removal - Alternative 2B</b>		
Project Number:		Date:	March 24, 2020

### 1.0 Purpose

---

The purpose of this estimate is to provide cost information to support King County's South Treatment Plant (STP) Flows and Loading Alternative Evaluation for the Nitrogen Removal Project. A series of alternatives have been developed for project evaluation to determine the best engineering and project cost solution.

This estimate was prepared to establish a King County Wastewater Treatment Division (WTD) pre-Class 5 conceptual cost estimate to provide order of magnitude cost to support WTD's capital project identification and budgeting process for Total Project Costs. The WTD pre-Class 5 estimate provides similar documentation to that of an AACE International Class 5 estimate. The range of anticipated project costs, per WTD estimating guidance, is -50% / +300%. The range of uncertainty is beyond that for a typical Class 5 estimate due to the scope being proximally defined with today's relative solutions and technologies to resolving the identified needs; when the projects move forward into capital delivery over the longer term, it is anticipated that many differences and changes may arise as the known and defined engineering solutions are developed.

Douglas Leo of Value Management Strategies, Inc. (VMS) prepared this Basis of Estimate in coordination with King County WTD, the Brown and Caldwell Engineers team, and the VMS estimating team after receiving scope information from WTD in October / November 2019 thru February 2020. This Basis of Estimate reflects VMS's best understanding of the estimating process for this project, as explained by King County WTD and Brown and Caldwell.

### 2.0 Project Scope Definition

---

This estimate includes all investigation, administration / owners' costs, engineering and design, purchases, fabrications, installations, process certifications, permitting, community impacts, and miscellaneous costs not specifically excluded elsewhere in this document.

Comprehensive Total Field Costs are generated from historical allowances, sources such as WTD estimating tools, historical costs, and RS Means / VMS estimating databases. All supporting indirect costs were generated from the WTD PRISM historical database. All costs included in the estimate reflect the best understanding of requirements as they existed at the time this estimate was prepared.

The scope of South Treatment Plant Flows and Loading Alternative 2B is to provide seasonal nitrogen removal (MLE and Sidestream anammox), with an effluent total inorganic nitrogen (TIN) limit of 8mg/L. The scope was developed to a Conceptual Design level adequate to assess operations and maintenance issues, energy impacts, permitting and code compliance issues, constructability, estimated costs, and implementation schedule.

The Project Estimate was prepared utilizing the following Work Breakdown Structure (WBS) in order to provide clarity and transparency to the estimated costs. The scope as identified for the alternative is described below in accordance with the WBS. Details are based on the known and defined scope in the design documents provided. See section 3.0 for a detailed list of Design Documents.

- A. Primary Effluent (PE)
  - *Not included in the scope for this alternative.*
- B. Aeration Basins
  - New Aeration Basin Train – purchase / install
  - Interior Cell Walls in New Aeration Basin
  - Baffle Walls in New Aeration Basins

## BASIS OF ESTIMATE

Project Name	<b>South Treatment Plant Nitrogen Removal - Alternative 2B</b>		
Project Number:		Date:	March 24, 2020

- Relocate Storage Building
  - Demo Storage Building
  - Relocate Construction Trailers
- C. Membrane Basins
- *Not included in the scope for this alternative*
- D. Internal Mixed Liquor Return (IMLR) Pumping
- IMLR Pumps – purchase/install
  - 36-inch CS Pipe per Aeration Basin
- E. Return Activated Sludge (RAS) Pump
- *Not included in the scope for this alternative*
- F. Sidestream Anammox
- Sidestream Anammox – purchase / install
  - Pumps, Skimmer / Chain / Flight for Sedimentation Tank, and Mixers
  - Centrate EQ Tanks (110K gal.)
  - Centrate Sedimentation Tank (192.3K gal.)
  - Anammox Reactor Tanks (500K gal.)
- G. Supplemental Methanol System
- Supplemental Methanol System 30K gal. – purchase / install
- H. Supplemental Alkalinity System
- Supplemental Alkalinity System 30K gal. – purchase / install
- I. Aeration Blowers
- Aeration Blowers – purchase / install
  - Aeration Blower Diffusers
  - Demolition Allowance
- J. Aeration Basin Mixers for Anoxic Zones
- Aeration Basin Mixers for Anoxic Zones
- K. Sidestream Bioaugmentation
- *Not included in the scope for this alternative*
- L. Tertiary Pumps
- *Not included in the scope for this alternative*
- M. Tertiary Fixed Film System
- *Not included in the scope for this alternative*
- N. Aeration / MBR Odor Control
- *Not included in the scope for this alternative*
- O. Primary Clarifier / Aerated Grit Tank
- *Not included in the scope for this alternative*
- P. Miscellaneous Scope
- ML to Secondary Clarifiers
  - RAS to Aeration Basins
  - PE to Aeration Basins
  - Centrate to Sidestream Anammox
  - Anammox Effluent to Thickener Overflow Piping

## BASIS OF ESTIMATE

Project Name	<b>South Treatment Plant Nitrogen Removal - Alternative 2B</b>		
Project Number:		Date:	March 24, 2020

- Alkalinity to RAS Mix Box
- Methanol to Aeration Basin

### 3.0 Design Basis

---

This is an AACE International Class 5 estimate with all required documentation. The estimate is based on engineering deliverables, scoping documentation, discussions with the project team, and all supporting information and documentation provided in October 2019 thru February 2020.

Engineering conceptual scope was provided in the following estimating deliverables. These are the most complete scoping documents that were available to the estimating provider.

Engineering and Estimating Deliverables provided include:

- Brown and Caldwell Markup, Existing aeration basins 1-4 retrofit assumptions for MLE (Alt 2A/2B/4C)
- Membrane feed pump station wetwell assumptions, undated
- New aeration basin example sketch for MLE (Alt 2A/2B/4C)
- New aeration basin example sketch for 4SMB (Alt 3A/3B/4A)
- Tertiary Feed Pump Station Wetwell sketch, (Alt 2A) and (Alt 4C/4D)
- Brown and Caldwell Layout, STP Nitrogen Removal Study, 9ea. Alternative Marked Up Sketches, undated
- Anammox Cap Cost Assumptions STP, undated
- SP Nitrogen Removal Alt. – Cost Estimating Assumptions, undated
- Velloa, Biostyr HGL drawing package, dated: 02.01.19
- Brown and Caldwell, General Process Arch. Structural drawing package, dated: November 1996
- South Treatment Plant, plant map, dated: June 2016
- Brown and Caldwell, Mechanical, Electrical, Instrumentation drawing package, dated: November 1996
- Brown and Caldwell, General Process and Instrumentation drawing package, dated: October 1993
- Brown and Caldwell, Architectural and Structural drawing package, dated: October 1993
- Brown and Caldwell, Mechanical drawing package, dated: October 1993
- Brown and Caldwell, General Process and Structural drawing package, dated: October 1993
- Brown and Caldwell, Mechanical and Electrical drawing package, dated: October 1993

Equipment Quotes:

- Next Turbo Budget Quote, Aeration Blowers, dated: 10.25.2019
- Suez Budget Quote, MBR, dated: 10.21.2019
- Ovivo Budget Quote, Sidestream Anammox, dated: 09.17.2019
- Biostyr Budget Quote, Tertiary, dated: 10.17.2019



## **BASIS OF ESTIMATE**

Project Name	<b>South Treatment Plant Nitrogen Removal - Alternative 2B</b>		
Project Number:		Date:	March 24, 2020

### **4.0 Planning Basis**

---

The following planning basis assumptions were made for the project estimate:

- No project construction plan is in place at this time.
- The assumed execution strategy is a standard workweek with limited overtime.
- No unusual site conditions have been considered as part of this estimate.
- Adequate available power exists at the site.

### **5.0 Cost Basis**

---

- All allied and indirect project costs (allowances for indeterminates, change order allowance, engineering, permitting, WTD staffing, etc.) have been estimated using WTD's PRISM cost model which is baselined to historical project costs.
- The estimate was performed based on drawings, sketches, and project information provided by King County and Brown and Caldwell Engineers.
- WTD is using a PRISM cost model dated January 26, 2017. All Allied and indirect project costs have been estimated using the new WTD PRISM cost model baselined to historical project costs.
- Additional technical project complexity factors for WTD indirect project costs have been introduced and incorporated into project allied costs to allow for development of an additional WTD indirect cost allowance, based upon the unique characteristics of the project.
- Equipment factors were developed utilizing historical data which accounts for specific install of the identified equipment within a normal battery limit. Specific scope relative to this project was used in the equipment factor determination. Factors for each specific type of equipment reflect the different complexity of the installation. Engineering supplied equipment costs were multiplied by the factors in order to estimate direct construction cost for the purchase and install of the equipment.
- Estimated costs incorporate prevailing King County wage rates.
- All costs were estimated in 1<sup>st</sup> Quarter 2020 dollars.

### **6.0 Allowances**

---

The level and types of allowances used in the estimate is as follows (common percentages for each alternative are shown and any estimate-specific differences are indicated):

- Sales Tax was included as 10.1% applied to the base construction cost, including the design and change order contingencies.
- A 25% Allowance for Indeterminates (AFI) is applied to the base construction cost. The AFI is an allowance that accounts for the cost of known but undefined requirements necessary for a complete and workable project. The AFI accounts for elements that are not explicitly shown in the project documents to be further defined as part of the design development and project delivery process. The AFI is carried at 25% at conceptual design, based on the WTD project delivery process.

## BASIS OF ESTIMATE

Project Name	<b>South Treatment Plant Nitrogen Removal - Alternative 2B</b>		
Project Number:		Date:	March 24, 2020

- Allowance of 10% for potential construction change orders.
- Allowance of 0.2% of the primary construction amount for miscellaneous direct capital costs.
- Allowance of 0.88% of the primary construction amount for permitting and other agency support.
- Allowance of 1.8% of the primary construction amount for miscellaneous services and material.
- Allowance of 0.65% of the primary construction amount for Non-WTD Support.
- Allowance of 1.0% of the primary construction amount for art initiatives.
- Allowance of 0.5% of the total project cost for sustainability.
- Allowance for application of total project contingency (see *Contingency* section below).
- Allowance of 18.23% of the primary construction amount for Engineering Services.
- Allowance of 7.81% of the primary construction amount for Construction Management Support
- Allowance of 12.57% of the primary construction amount for WTD staff labor and burden.
- No Escalation has been included.
- Additional estimating allowances for WTD indirect costs of approximately \$24.1 million have been included in the Total Project Cost estimate by using a moderate degree of complexity rating for Design Engineering, Construction Management, Permitting and License, Operations Support, Community Relations, and Project Management. All other indirect costs were considered routine. Complexity factors were calibrated based on comments received from King County on March 4, 2020.
  - An allowance of \$18.1 million for Design and Construction Consulting
  - An allowance of \$0.87 million for Permitting & Other Agency Support
  - An allowance of \$5.1 million for WTD Staff Labor

## 7.0 Assumptions

---

Any other assumptions made by the estimator but not documented elsewhere in the estimate basis are included in this section.

- All costs included in the estimate reflect the best understanding of requirements as they existed at the time the estimates were prepared. Any modifications to the present scope and/or location of the project site may have substantial cost and schedule impacts.
- The engineering design will be performed by an external consultant engineer.
- Construction management will not be performed “in-house” by WTD. It will be performed by an external consultant construction manager.
- The project will generally align with the WTD PRISM cost model for Treatment projects.
- All work will always be performed utilizing safe work methods.
- Work will be sequenced to minimize standard process, service, and community interruptions. However, no costs are included to address sequencing necessary to keep the plant operational during construction.

## **BASIS OF ESTIMATE**

Project Name	<b>South Treatment Plant Nitrogen Removal - Alternative 2B</b>		
Project Number:		Date:	March 24, 2020

- No costs are included for any new facilities that would be required, beyond the scope of this project to replace any lost capacity to the South Treatment Plant.
- It is assumed that the best improvement solution is included in the project scope(s).
- There will be some degree of productivity loss due to the site location. Some degree of productivity loss is included in the estimated costs. Any unusual site conditions are not accounted for in this estimate.
- Any additional work discovered during project implementation would need to be either a supplemental approval of added scope or be approved as an additional project.
- This project will be engineered to meet Washington State area seismic requirements.
- A degree of minimal cost rounding will occur during the normal estimating process.
- No allowance is included for Material Pricing Uncertainty.
- Power is not readily available in the general area of this project. New power sources are included in the scope of this project.
- It is assumed that some general material contamination is present. The estimate covers minimal cost of removal wherever the contamination is disturbed during construction. This cost is covered in productivity rates utilized in the estimate.

### **8.0 Exclusions**

---

All potential items of cost which might be associated with the project but for which no costs have been included are listed below:

- No asbestos removal costs are included.
- No estimated costs are included for any potential delays due to interferences.
- No costs are included for utility relocations.
- No costs are included for temporary construction easements.
- No costs are included for street use or street improvement permits.
- No costs are included for additional scope beyond that as detailed in the current scope of work.

### **9.0 Exceptions**

---

This estimate is classified as a King County Wastewater Treatment Division Class 5 estimate based on an AACE International Class 5 estimate, with no exceptions per the King County WTD project process, for the scope as known at the time of the estimate preparation.

### **10.0 Risks (Threats and Opportunities)**

---

At the time of estimate preparation, a formal risk analysis session had not been conducted. General potential risks are listed below.

## **BASIS OF ESTIMATE**

Project Name	<b>South Treatment Plant Nitrogen Removal - Alternative 2B</b>		
Project Number:		Date:	March 24, 2020

- There is a risk that additional scope, technology advances or major deviation from the suggested project scope will adversely impact cost and schedule.
- Future unknown or changing site conditions present a risk around productivities, schedule, and costs.
- More stringent or completely new regulations, usage fees, permitting, or environmental impacts may result in risks that could adversely impact cost and schedule.
- Potential complex construction and constructability issues could arise during construction, resulting in major design/construction changes.
- The space constraints could significantly impact assumed productivities and crew sizes identified for the estimated concept, resulting in increased costs due to loss of production.
- The scheduled timing of project execution will greatly impact the bottom-line costs. There is risk related to labor availability and fluctuating commodity and equipment pricing in the timeframe between this early conceptual estimate and the actual execution of the project. Rising costs due to inflation, escalation and competing major worldwide projects pose the possibility of noticeable project cost and schedule increases.
- Weather conditions and emergency service interruptions present the possibility of negative schedule and cost impacts.
- Any possible coordination with other agencies could result in potential impacts on costs, schedule and Project Definition process.
- There is a risk that stakeholders could oppose the proposed design or prefer a different approach or site to be selected, resulting in schedule delays and a higher cost alternative.

### **11.0 Contingency**

---

Contingency is a cost element of the estimate used to cover uncertainties and unforeseeable elements of cost within the defined project scope. Contingency covers inadequacies in project scope definition, estimating methods, and estimating data. Contingency specifically excludes changes in project scope, and unforeseen major events such as earthquakes, prolonged labor strikes, etc.

A 30% Project Contingency was added to the base estimate of Total Project Costs (direct and indirect) as a result of the project estimating process and in accordance with the King County WTD project delivery process.

The estimating analysis resulted in a project contingency of approximately \$106.6 million (US\$).

The total project cost at a 50% confidence level (P50) is typically used for funding and baselining of a project at this stage and level of engineering and project development. The P50 confidence level suggests that there is a 50% cumulative probability of project cost under-run (or 50% probability of exceedance) at this dollar amount for the presently defined and known project scope.

### **12.0 Management Reserve**

---

No allocation of costs was included in this estimate for Management Reserves.

Contingency is not intended to cover the costs for changes in project scope. If the project needs to provide an allowance for anticipated changes in scope or to cover the costs for items that may be required but

## **BASIS OF ESTIMATE**

Project Name	<b>South Treatment Plant Nitrogen Removal - Alternative 2B</b>		
Project Number:		Date:	March 24, 2020

have not yet been specifically identified as being included in the current project scope, then that amount of cost should be identified here.

### **13.0 Reconciliation**

---

Reconciliation was not conducted at this time.

### **14.0 Benchmarking**

---

All included Allied Costs as supplied by the PRISM historical database have been benchmarked against a similar portfolio of recently completed projects.

### **15.0 Estimate Quality Assurance Plan**

---

No reviews of total project costs have been conducted outside the reviews conducted within Brown and Caldwell and VMS estimating team. It is anticipated that upon completion of this estimate, reviews will happen between the estimate provider and WTD.

### **16.0 Attachments**

---

#### **Attachment: Estimate Deliverables**

Engineering and Estimating Deliverables provided include:

- Brown and Caldwell Markup, Existing aeration basins 1-4 retrofit assumptions for MLE (Alt 2A/2B/4C)
- Membrane feed pump station wetwell assumptions, undated
- New aeration basin example sketch for MLE (Alt 2A/2B/4C)
- New aeration basin example sketch for 4SMB (Alt 3A/3B/4A)
- Tertiary Feed Pump Station Wetwell sketch, (Alt 2A) and (Alt 4C/4D)
- Brown and Caldwell Layout, STP Nitrogen Removal Study, 9ea. Alternative Marked Up Sketches, undated
- Anammox Cap Cost Assumptions STP, undated
- SP Nitrogen Removal Alt. – Cost Estimating Assumptions, undated
- Veloa, Biostyr HGL drawing package, dated: 02.01.19
- Brown and Caldwell, General Process Arch. Structural drawing package, dated: November 1996
- South Treatment Plant, plant map, dated: June 2016
- Brown and Caldwell, Mechanical, Electrical, Instrumentation drawing package, dated: November 1996
- Brown and Caldwell, General Process and Instrumentation drawing package, dated: October 1993
- Brown and Caldwell, Architectural and Structural drawing package, dated: October 1993
- Brown and Caldwell, Mechanical drawing package, dated: October 1993
- Brown and Caldwell, General Process and Structural drawing package, dated: October 1993
- Brown and Caldwell, Mechanical and Electrical drawing package, dated: October 1993

Equipment Quotes:

- Next Turbo Budget Quote, Aeration Blowers, dated: 10.25.2019

## BASIS OF ESTIMATE

Project Name	<b>South Treatment Plant Nitrogen Removal - Alternative 2B</b>		
Project Number:		Date:	March 24, 2020

- Suez Budget Quote, MBR, dated: 10.21.2019
- Ovivo Budget Quote, Sidestream Anammox, dated: 09.17.2019
- Biostyr Budget Quote, Tertiary, dated: 10.17.2019





# King County

Department of Natural Resources and Parks  
Wastewater Treatment Division

## Project Planning and Delivery Section

### BASIS OF ESTIMATE

---

Project Name	<b>South Treatment Plant Nitrogen Removal - Alternative 3A</b>
Project Number	
Date Prepared	March 24, 2020
Requested by	Tiffany Knapp, King County WTD
Prepared by	Douglas W. Leo, CCP, CEP, FRICS, FAACE Hon. Life, (VMS, Inc.)
Estimate Classification	WTD Class 5
Estimate Purpose	King County Class 5 Concept Screening
Estimate ID (Version)	6
Project Manager	Eron Jacobson, King County WTD
Project Control Engineer	
Cc or Distribution List	

*Note that the accuracy of the associated cost estimate is dependent upon the various underlying assumptions, inclusions, and exclusions described herein. Actual project costs may differ and can be significantly affected by factors such as changes in the external environment, the manner in which the project is executed and controlled, and other factors that may impact the estimate basis or otherwise affect the project. Estimate accuracy ranges are only assessments based upon the cost estimating methods and data employed in preparing the estimate and are not a guarantee of actual project costs.*

## BASIS OF ESTIMATE

Project Name	<b>South Treatment Plant Nitrogen Removal - Alternative 3A</b>		
Project Number:		Date:	March 24, 2020

### 1.0 Purpose

---

The purpose of this estimate is to provide cost information to support King County's South Treatment Plant (STP) Flows and Loading Alternative Evaluation for the Nitrogen Removal Project. A series of alternatives have been developed for project evaluation to determine the best engineering and project cost solution.

This estimate was prepared to establish a King County Wastewater Treatment Division (WTD) pre-Class 5 conceptual cost estimate to provide order of magnitude cost to support WTD's capital project identification and budgeting process for Total Project Costs. The WTD pre-Class 5 estimate provides similar documentation to that of an AACE International Class 5 estimate. The range of anticipated project costs, per WTD estimating guidance, is -50% / +300%. The range of uncertainty is beyond that for a typical Class 5 estimate due to the scope being proximally defined with today's relative solutions and technologies to resolving the identified needs; when the projects move forward into capital delivery over the longer term, it is anticipated that many differences and changes may arise as the known and defined engineering solutions are developed.

Douglas Leo of Value Management Strategies, Inc. (VMS) prepared this Basis of Estimate in coordination with King County WTD, the Brown and Caldwell Engineers team, and the VMS estimating team after receiving scope information from WTD in October/November 2019 thru February 2020. This Basis of Estimate reflects VMS's best understanding of the estimating process for this project, as explained by King County WTD and Brown and Caldwell.

### 2.0 Project Scope Definition

---

This estimate includes all investigation, administration / owners' costs, engineering and design, purchases, fabrications, installations, process certifications, permitting, community impacts, and miscellaneous costs not specifically excluded elsewhere in this document.

Comprehensive Total Field Costs are generated from historical allowances, sources such as WTD estimating tools, historical costs, and RS Means / VMS estimating databases. All supporting indirect costs were generated from the WTD PRISM historical database. All costs included in the estimate reflect the best understanding of requirements as they existed at the time this estimate was prepared.

The scope of South Treatment Plant Flows and Loading Alternative 3A is to provide Year-Round nitrogen removal (4SMB and Sidestream Anammox), with an effluent TIN limit of 8mg/L. The scope was developed to a Conceptual Design level adequate to assess operations and maintenance issues, energy impacts, permitting and code compliance issues, constructability, estimated costs, and implementation schedule.

The Project Estimate was prepared utilizing the following Work Breakdown Structure (WBS) in order to provide clarity and transparency to the estimated costs. The scope as identified for the alternative is described below in accordance with the WBS. Details are based on the known and defined scope in the design documents provided. See section 3.0 for a detailed list of Design Documents.

- A. Primary Effluent (PE)
  - *Not included in the scope for this alternative.*
- B. Aeration Basins
  - New Aeration Basin Train – purchase / install
  - Interior Cell Walls in New Aeration Basin
  - Baffle Walls in New Aeration Basins
  - Baffle Walls in Existing Aeration Basins
  - Rebuild Storage Building

## BASIS OF ESTIMATE

Project Name	<b>South Treatment Plant Nitrogen Removal - Alternative 3A</b>		
Project Number:		Date:	March 24, 2020

- Demo Storage Building
- Relocate Construction Trailers
- C. Membrane Basins
  - *Not included in the scope for this alternative*
- D. Internal Mixed Liquor Return (IMLR) Pumping
  - IMLR Pumps – purchase / install
  - 36-inch CS Pipe per Aeration Basin
- E. Return Activated Sludge (RAS) Pump
  - *Not included in the scope for this alternative*
- F. Sidestream Anammox
  - Sidestream Anammox – purchase / install
  - Pumps, Skimmer / Chain / Flight for Sedimentation Tank, and Mixers
  - Centrate EQ Tanks (110K gal.)
  - Centrate Sedimentation Tank (192.3K gal.)
  - Anammox Reactor Tanks (500K gal.)
- G. Supplemental Methanol System
  - Supplemental Methanol System 15K gal. – purchase / install
- H. Supplemental Alkalinity System
  - Supplemental Alkalinity System 45K gal. – purchase / install
- I. Aeration Blowers
  - Aeration Blowers – purchase / install
  - Aeration Blower Diffusers
  - Demolition Allowance
- J. Aeration Basin Mixers for Anoxic Zones
  - Aeration Basin Mixers for Anoxic Zones
- K. Sidestream Bioaugmentation
  - *Not included in the scope for this alternative*
- L. Tertiary Pumps
  - *Not included in the scope for this alternative*
- M. Tertiary Fixed Film System
  - *Not included in the scope for this alternative*
- N. Aeration / MBR Odor Control
  - *Not included in the scope for this alternative*
- O. Primary Clarifier / Aerated Grit Tank
  - *Not included in the scope for this alternative*
- P. Miscellaneous Scope
  - ML to Secondary Clarifiers
  - RAS to Aeration Basins
  - PE to Aeration Basin
  - Centrate to Sidestream Anammox
  - Anammox Effluent to Thickener Overflow Piping
  - Alkalinity to RAS Mix Box

## BASIS OF ESTIMATE

Project Name	<b>South Treatment Plant Nitrogen Removal - Alternative 3A</b>		
Project Number:		Date:	March 24, 2020

- Methanol to Aeration Basin

### 3.0 Design Basis

---

This is an AACE International Class 5 estimate with all required documentation. The estimate is based on engineering deliverables, scoping documentation, discussions with the project team, and all supporting information and documentation provided in October 2019 thru February 2020.

Engineering conceptual scope was provided in the following estimating deliverables. These are the most complete scoping documents that were available to the estimating provider.

Engineering and Estimating Deliverables provided include:

- Brown and Caldwell Markup, Existing aeration basins 1-4 retrofit assumptions for MLE (Alt 2A/2B/4C)
- Membrane feed pump station wetwell assumptions, undated
- New aeration basin example sketch for MLE (Alt 2A/2B/4C)
- New aeration basin example sketch for 4SMB (Alt 3A/3B/4A)
- Tertiary Feed Pump Station Wetwell sketch, (Alt 2A) and (Alt 4C/4D)
- Brown and Caldwell Layout, STP Nitrogen Removal Study, 9ea. Alternative Marked Up Sketches, undated
- Anammox Cap Cost Assumptions STP, undated
- SP Nitrogen Removal Alt. – Cost Estimating Assumptions, undated
- Vello, Biostyr HGL drawing package, dated: 02.01.19
- Brown and Caldwell, General Process Arch. Structural drawing package, dated: November 1996
- South Treatment Plant, plant map, dated: June 2016
- Brown and Caldwell, Mechanical, Electrical, Instrumentation drawing package, dated: November 1996
- Brown and Caldwell, General Process and Instrumentation drawing package, dated: October 1993
- Brown and Caldwell, Architectural and Structural drawing package, dated: October 1993
- Brown and Caldwell, Mechanical drawing package, dated: October 1993
- Brown and Caldwell, General Process and Structural drawing package, dated: October 1993
- Brown and Caldwell, Mechanical and Electrical drawing package, dated: October 1993

Equipment Quotes:

- Next Turbo Budget Quote, Aeration Blowers, dated: 10.25.2019
- Suez Budget Quote, MBR, dated: 10.21.2019
- Ovivo Budget Quote, Sidestream Anammox, dated: 09.17.2019
- Biostyr Budget Quote, Tertiary, dated: 10.17.2019

## **BASIS OF ESTIMATE**

Project Name	<b>South Treatment Plant Nitrogen Removal - Alternative 3A</b>		
Project Number:		Date:	March 24, 2020

### **4.0 Planning Basis**

---

The following planning basis assumptions were made for the project estimate:

- No project construction plan is in place at this time.
- The assumed execution strategy is a standard workweek with limited overtime.
- No unusual site conditions have been considered as part of this estimate.
- Adequate available power exists at the site.

### **5.0 Cost Basis**

---

- All allied and indirect project costs (allowances for indeterminates, change order allowance, engineering, permitting, WTD staffing, etc.) have been estimated using WTD's PRISM cost model which is baselined to historical project costs.
- The estimate was performed based on drawings, sketches, and project information provided by King County and Brown and Caldwell Engineers.
- WTD is using a PRISM cost model dated January 26, 2017. All Allied and indirect project costs have been estimated using the new WTD PRISM cost model baselined to historical project costs.
- Additional technical project complexity factors for WTD indirect project costs have been introduced and incorporated into project allied costs to allow for development of an additional WTD indirect cost allowance, based upon the unique characteristics of the project.
- Equipment factors were developed utilizing historical data which accounts for specific install of the identified equipment within a normal battery limit. Specific scope relative to this project was used in the equipment factor determination. Factors for each specific type of equipment reflect the different complexity of the installation. Engineering supplied equipment costs were multiplied by the factors in order to estimate direct construction cost for the purchase and install of the equipment.
- Estimated costs incorporate prevailing King County wage rates.
- All costs were estimated in 1<sup>st</sup> Quarter 2020 dollars.

### **6.0 Allowances**

---

The level and types of allowances used in the estimate is as follows (common percentages for each alternative are shown and any estimate-specific differences are indicated):

- Sales Tax was included as 10.1% applied to the base construction cost, including the design and change order contingencies.
- A 25% Allowance for Indeterminates (AFI) is applied to the base construction cost. The AFI is an allowance that accounts for the cost of known but undefined requirements necessary for a complete and workable project. The AFI accounts for elements that are not explicitly shown in the project documents to be further defined as part of the design development and project delivery process. The AFI is carried at 25% at conceptual design, based on the WTD project delivery process.

## BASIS OF ESTIMATE

Project Name	<b>South Treatment Plant Nitrogen Removal - Alternative 3A</b>		
Project Number:		Date:	March 24, 2020

- Allowance of 10% for potential construction change orders.
- Allowance of 0.2% of the primary construction amount for miscellaneous direct capital costs.
- Allowance of 0.88% of the primary construction amount for permitting and other agency support.
- Allowance of 1.8% of the primary construction amount for miscellaneous services and material.
- Allowance of 0.65% of the primary construction amount for Non-WTD Support.
- Allowance of 1.0% of the primary construction amount for art initiatives.
- Allowance of 0.5% of the total project cost for sustainability.
- Allowance for application of total project contingency (see *Contingency* section below).
- Allowance of 17.02% of the primary construction amount for Engineering Services.
- Allowance of 7.11% of the primary construction amount for Construction Management Support
- Allowance of 12.41% of the primary construction amount for WTD staff labor and burden.
- No Escalation has been included.
- Additional estimating allowances for WTD indirect costs of approximately \$35.8 million have been included in the Total Project Cost estimate by using a moderate degree of complexity rating for Design Engineering, Construction Management, Permitting and Licenses, Operations Support, Community Relations, Project Management, and Project Controls. All other indirect costs were considered routine. Complexity factors were calibrated based on comments received from King County on March 4, 2020.
  - An allowance of \$26.1 million for Design and Construction Consulting
  - An allowance of \$1.36 million for Permitting & Other Agency Support
  - An allowance of \$8.33 million for WTD Staff Labor

### 7.0 Assumptions

---

Any other assumptions made by the estimator but not documented elsewhere in the estimate basis are included in this section.

- All costs included in the estimate reflect the best understanding of requirements as they existed at the time the estimates were prepared. Any modifications to the present scope and/or location of the project site may have substantial cost and schedule impacts.
- The engineering design will be performed by an external consultant engineer.
- Construction management will not be performed “in-house” by WTD. It will be performed by an external consultant construction manager.
- The project will generally align with the WTD PRISM cost model for Treatment projects.
- All work will always be performed utilizing safe work methods.
- Work will be sequenced to minimize standard process, service, and community interruptions. However, no costs are included to address sequencing necessary to keep the plant operational during construction.

## **BASIS OF ESTIMATE**

Project Name	<b>South Treatment Plant Nitrogen Removal - Alternative 3A</b>		
Project Number:		Date:	March 24, 2020

- No costs are included for any new facilities that would be required, beyond the scope of this project to replace any lost capacity to the South Treatment Plant.
- It is assumed that the best improvement solution is included in the project scope(s).
- There will be some degree of productivity loss due to the site location. Some degree of productivity loss is included in the estimated costs. Any unusual site conditions are not accounted for in this estimate.
- Any additional work discovered during project implementation would need to be either a supplemental approval of added scope or be approved as an additional project.
- This project will be engineered to meet Washington State area seismic requirements.
- A degree of minimal cost rounding will occur during the normal estimating process.
- No allowance is included for Material Pricing Uncertainty.
- Power is not readily available in the general area of this project. New power sources are included in the scope of this project.
- It is assumed that some general material contamination is present. The estimate covers minimal cost of removal wherever the contamination is disturbed during construction. This cost is covered in productivity rates utilized in the estimate.

### **8.0 Exclusions**

---

All potential items of cost which might be associated with the project but for which no costs have been included are listed below:

- No asbestos removal costs are included.
- No estimated costs are included for any potential delays due to interferences.
- No costs are included for utility relocations.
- No costs are included for temporary construction easements.
- No costs are included for street use or street improvement permits.
- No costs are included for additional scope beyond that as detailed in the current scope of work.

### **9.0 Exceptions**

---

This estimate is classified as a King County Wastewater Treatment Division Class 5 estimate based on an AACE International Class 5 estimate, with no exceptions per the King County WTD project process, for the scope as known at the time of the estimate preparation.

### **10.0 Risks (Threats and Opportunities)**

---

At the time of estimate preparation, a formal risk analysis session had not been conducted. General potential risks are listed below.

- There is a risk that additional scope, technology advances or major deviation from the suggested project scope will adversely impact cost and schedule.



## BASIS OF ESTIMATE

Project Name	<b>South Treatment Plant Nitrogen Removal - Alternative 3A</b>		
Project Number:		Date:	March 24, 2020

- Future unknown or changing site conditions present a risk around productivities, schedule, and costs.
- More stringent or completely new regulations, usage fees, permitting, or environmental impacts may result in risks that could adversely impact cost and schedule.
- Potential complex construction and constructability issues could arise during construction, resulting in major design / construction changes.
- The space constraints could significantly impact assumed productivities and crew sizes identified for the estimated concept, resulting in increased costs due to loss of production.
- The scheduled timing of project execution will greatly impact the bottom-line costs. There is risk related to labor availability and fluctuating commodity and equipment pricing in the timeframe between this early conceptual estimate and the actual execution of the project. Rising costs due to inflation, escalation and competing major worldwide projects pose the possibility of noticeable project cost and schedule increases.
- Weather conditions and emergency service interruptions present the possibility of negative schedule and cost impacts.
- Any possible coordination with other agencies could result in potential impacts on costs, schedule and Project Definition process.
- There is a risk that stakeholders could oppose the proposed design or prefer a different approach or site to be selected, resulting in schedule delays and a higher cost alternative.

### 11.0 Contingency

---

Contingency is a cost element of the estimate used to cover uncertainties and unforeseeable elements of cost within the defined project scope. Contingency covers inadequacies in project scope definition, estimating methods, and estimating data. Contingency specifically excludes changes in project scope, and unforeseen major events such as earthquakes, prolonged labor strikes, etc.

A 30% Project Contingency was added to the base estimate of Total Project Costs (direct and indirect) as a result of the project estimating process and in accordance with the King County WTD project delivery process.

The estimating analysis resulted in a project contingency of approximately \$163.47 million (US\$).

The total project cost at a 50% confidence level (P50) is typically used for funding and baselining of a project at this stage and level of engineering and project development. The P50 confidence level suggests that there is a 50% cumulative probability of project cost under-run (or 50% probability of exceedance) at this dollar amount for the presently defined and known project scope.

### 12.0 Management Reserve

---

No allocation of costs was included in this estimate for Management Reserves.

Contingency is not intended to cover the costs for changes in project scope. If the project needs to provide an allowance for anticipated changes in scope or to cover the costs for items that may be required but have not yet been specifically identified as being included in the current project scope, then that amount of cost should be identified here.

## **BASIS OF ESTIMATE**

Project Name	<b>South Treatment Plant Nitrogen Removal - Alternative 3A</b>		
Project Number:		Date:	March 24, 2020

### **13.0 Reconciliation**

---

Reconciliation was not conducted at this time.

### **14.0 Benchmarking**

---

All included Allied Costs as supplied by the PRISM historical database have been benchmarked against a similar portfolio of recently completed projects.

### **15.0 Estimate Quality Assurance Plan**

---

No reviews of total project costs have been conducted outside the reviews conducted within Brown and Caldwell and VMS estimating team. It is anticipated that upon completion of this estimate, reviews will happen between the estimate provider and WTD.

### **16.0 Attachments**

---

#### **Attachment: Estimate Deliverables**

Engineering and Estimating Deliverables provided include:

- Brown and Caldwell Markup, Existing aeration basins 1-4 retrofit assumptions for MLE (Alt 2A/2B/4C)
- Membrane feed pump station wetwell assumptions, undated
- New aeration basin example sketch for MLE (Alt 2A/2B/4C)
- New aeration basin example sketch for 4SMB (Alt 3A/3B/4A)
- Tertiary Feed Pump Station Wetwell sketch, (Alt 2A) and (Alt 4C/4D)
- Brown and Caldwell Layout, STP Nitrogen Removal Study, 9ea. Alternative Marked Up Sketches, undated
- Anammox Cap Cost Assumptions STP, undated
- SP Nitrogen Removal Alt. – Cost Estimating Assumptions, undated
- Velloa, Biostyr HGL drawing package, dated: 02.01.19
- Brown and Caldwell, General Process Arch. Structural drawing package, dated: November 1996
- South Treatment Plant, plant map, dated: June 2016
- Brown and Caldwell, Mechanical, Electrical, Instrumentation drawing package, dated: November 1996
- Brown and Caldwell, General Process and Instrumentation drawing package, dated: October 1993
- Brown and Caldwell, Architectural and Structural drawing package, dated: October 1993
- Brown and Caldwell, Mechanical drawing package, dated: October 1993
- Brown and Caldwell, General Process and Structural drawing package, dated: October 1993
- Brown and Caldwell, Mechanical and Electrical drawing package, dated: October 1993

Equipment Quotes:

- Next Turbo Budget Quote, Aeration Blowers, dated: 10.25.2019

## BASIS OF ESTIMATE

Project Name	<b>South Treatment Plant Nitrogen Removal - Alternative 3A</b>		
Project Number:		Date:	March 24, 2020

- Suez Budget Quote, MBR, dated: 10.21.2019
- Ovivo Budget Quote, Sidestream Anammox, dated: 09.17.2019
- Biostyr Budget Quote, Tertiary, dated: 10.17.2019



# King County

Department of Natural Resources and Parks  
Wastewater Treatment Division

## Project Planning and Delivery Section

### BASIS OF ESTIMATE

---

Project Name	<b>South Treatment Plant Nitrogen Removal - Alternative 3B</b>
Project Number	
Date Prepared	March 24, 2020
Requested by	Tiffany Knapp, King County WTD
Prepared by	Douglas W. Leo, CCP, CEP, FRICS, FAACE Hon. Life, (VMS, Inc.)
Estimate Classification	WTD Class 5
Estimate Purpose	King County Class 5 Concept Screening
Estimate ID (Version)	6
Project Manager	Eron Jacobson, King County WTD
Project Control Engineer	
Cc or Distribution List	

*Note that the accuracy of the associated cost estimate is dependent upon the various underlying assumptions, inclusions, and exclusions described herein. Actual project costs may differ and can be significantly affected by factors such as changes in the external environment, the manner in which the project is executed and controlled, and other factors that may impact the estimate basis or otherwise affect the project. Estimate accuracy ranges are only assessments based upon the cost estimating methods and data employed in preparing the estimate and are not a guarantee of actual project costs.*

## BASIS OF ESTIMATE

Project Name	<b>South Treatment Plant Nitrogen Removal - Alternative 3B</b>		
Project Number:		Date:	March 24, 2020

### 1.0 Purpose

---

The purpose of this estimate is to provide cost information to support King County's South Treatment Plant (STP) Flows and Loading Alternative Evaluation for the Nitrogen Removal Project. A series of alternatives have been developed for project evaluation to determine the best engineering and project cost solution.

This estimate was prepared to establish a King County Wastewater Treatment Division (WTD) pre-Class 5 conceptual cost estimate to provide order of magnitude cost to support WTD's capital project identification and budgeting process for Total Project Costs. The WTD pre-Class 5 estimate provides similar documentation to that of an AACE International Class 5 estimate. The range of anticipated project costs, per WTD estimating guidance, is -50% / +300%. The range of uncertainty is beyond that for a typical Class 5 estimate due to the scope being proximally defined with today's relative solutions and technologies to resolving the identified needs; when the projects move forward into capital delivery over the longer term, it is anticipated that many differences and changes may arise as the known and defined engineering solutions are developed.

Douglas Leo of Value Management Strategies, Inc. (VMS) prepared this Basis of Estimate in coordination with King County WTD, the Brown and Caldwell Engineers team, and the VMS estimating team after receiving scope information from WTD in October/November 2019 thru February 2020. This Basis of Estimate reflects VMS's best understanding of the estimating process for this project, as explained by King County WTD and Brown and Caldwell.

### 2.0 Project Scope Definition

---

This estimate includes all investigation, administration / owners' costs, engineering and design, purchases, fabrications, installations, process certifications, permitting, community impacts, and miscellaneous costs not specifically excluded elsewhere in this document.

Comprehensive Total Field Costs are generated from historical allowances, sources such as WTD estimating tools, historical costs, and RS Means / VMS estimating databases. All supporting indirect costs were generated from the WTD PRISM historical database. All costs included in the estimate reflect the best understanding of requirements as they existed at the time this estimate was prepared.

The scope of South Treatment Plant Flows and Loading Alternative 3B is to provide Year-Round nitrogen removal (4SMB and Sidestream bioaugmentation), with an effluent total inorganic nitrogen (TIN) limit of 8mg/L. The scope was developed to a Conceptual Design level adequate to assess operations and maintenance issues, energy impacts, permitting and code compliance issues, constructability, estimated costs, and implementation schedule.

The Project Estimate was prepared utilizing the following Work Breakdown Structure (WBS) in order to provide clarity and transparency to the estimated costs. The scope as identified for the alternative is described below in accordance with the WBS. Details are based on the known and defined scope in the design documents provided. See section 3.0 for a detailed list of Design Documents.

- A. Primary Effluent (PE)
  - *Not included in the scope for this alternative.*
- B. Aeration Basins
  - New Aeration Basin Train – purchase / install
  - Interior Cell Walls in New Aeration Basin
  - Baffle Walls in New Aeration Basin

## BASIS OF ESTIMATE

Project Name	<b>South Treatment Plant Nitrogen Removal - Alternative 3B</b>		
Project Number:		Date:	March 24, 2020

- Baffle Walls in Existing Aeration Basins
  - Relocate Storage Building
  - Demo Storage Building
  - Relocate Construction Trailers
- C. Membrane Basins
- *Not included in the scope for this alternative*
- D. Internal Mixed Liquor Return (IMLR) Pumping
- IMLR Pumps – purchase / install
  - 36-inch CS Pipe per Aeration Basin
- E. Return Activated Sludge (RAS) Pump
- *Not included in the scope for this alternative*
- F. Sidestream Anammox
- *Not included in the scope for this alternative*
- G. Supplemental Methanol System
- Supplemental Methanol System 15K gal. – purchase/install
- H. Supplemental Alkalinity System
- Supplemental Alkalinity System 45K gal. – purchase/install
- I. Aeration Blowers
- Aeration Blowers – purchase / install
  - Aeration Blower Diffusers
  - Demolition Allowance
- J. Aeration Basin Mixers for Anoxic Zones
- Aeration Basin Mixers for Anoxic Zones
- K. Sidestream Bioaugmentation
- Bioaugmentation Tank – purchase / install
- L. Tertiary Pumps
- *Not included in the scope for this alternative*
- M. Tertiary Fixed Film System
- *Not included in the scope for this alternative*
- N. Aeration / MBR Odor Control
- *Not included in the scope for this alternative*
- O. Primary Clarifier / Aerated Grit Tank
- *Not included in the scope for this alternative*
- P. Misc. Undefined Scope
- ML to Secondary Clarifiers
  - RAS to Aeration Basins
  - RAS to Sidestream Bioaugmentation Tank
  - PE to Aeration Basins
  - Alkalinity to RAS Mix Box
  - Methanol to Aeration Basin
  - Allowance for Upgraded Plant Electrical Power

## **BASIS OF ESTIMATE**

Project Name	<b>South Treatment Plant Nitrogen Removal - Alternative 3B</b>		
Project Number:		Date:	March 24, 2020

### **3.0 Design Basis**

---

This is an AACE International Class 5 estimate with all required documentation. The estimate is based on engineering deliverables, scoping documentation, discussions with the project team, and all supporting information and documentation provided in October 2019 thru February 2020.

Engineering conceptual scope was provided in the following estimating deliverables. These are the most complete scoping documents that were available to the estimating provider.

Engineering and Estimating Deliverables provided include:

- Brown and Caldwell Markup, Existing aeration basins 1-4 retrofit assumptions for MLE (Alt 2A/2B/4C)
- Membrane feed pump station wetwell assumptions, undated
- New aeration basin example sketch for MLE (Alt 2A/2B/4C)
- New aeration basin example sketch for 4SMB (Alt 3A/3B/4A)
- Tertiary Feed Pump Station Wetwell sketch, (Alt 2A) and (Alt 4C/4D)
- Brown and Caldwell Layout, STP Nitrogen Removal Study, 9ea. Alternative Marked Up Sketches, undated
- Anammox Cap Cost Assumptions STP, undated
- SP Nitrogen Removal Alt. – Cost Estimating Assumptions, undated
- Velloa, Biostyr HGL drawing package, dated: 02.01.19
- Brown and Caldwell, General Process Arch. Structural drawing package, dated: November 1996
- South Treatment Plant, plant map, dated: June 2016
- Brown and Caldwell, Mechanical, Electrical, Instrumentation drawing package, dated: November 1996
- Brown and Caldwell, General Process and Instrumentation drawing package, dated: October 1993
- Brown and Caldwell, Architectural and Structural drawing package, dated: October 1993
- Brown and Caldwell, Mechanical drawing package, dated: October 1993
- Brown and Caldwell, General Process and Structural drawing package, dated: October 1993
- Brown and Caldwell, Mechanical and Electrical drawing package, dated: October 1993

Equipment Quotes:

- Next Turbo Budget Quote, Aeration Blowers, dated: 10.25.2019
- Suez Budget Quote, MBR, dated: 10.21.2019
- Ovivo Budget Quote, Sidestream Anammox, dated: 09.17.2019
- Biostyr Budget Quote, Tertiary, dated: 10.17.2019

### **4.0 Planning Basis**

---

The following planning basis assumptions were made for the project estimate:

- No project construction plan is in place at this time.
- The assumed execution strategy is a standard workweek with limited overtime.
- No unusual site conditions have been considered as part of this estimate.



## **BASIS OF ESTIMATE**

Project Name	<b>South Treatment Plant Nitrogen Removal - Alternative 3B</b>		
Project Number:		Date:	March 24, 2020

- Adequate available power exists at the site.

### **5.0 Cost Basis**

---

- All allied and indirect project costs (allowances for indeterminates, change order allowance, engineering, permitting, WTD staffing, etc.) have been estimated using WTD's PRISM cost model which is baselined to historical project costs.
- The estimate was performed based on drawings, sketches, and project information provided by King County and Brown and Caldwell Engineers.
- WTD is using a PRISM cost model dated January 26, 2017. All Allied and indirect project costs have been estimated using the new WTD PRISM cost model baselined to historical project costs.
- Additional technical project complexity factors for WTD indirect project costs have been introduced and incorporated into project allied costs to allow for development of an additional WTD indirect cost allowance, based upon the unique characteristics of the project.
- Equipment factors were developed utilizing historical data which accounts for specific install of the identified equipment within a normal battery limit. Specific scope relative to this project was used in the equipment factor determination. Factors for each specific type of equipment reflect the different complexity of the installation. Engineering supplied equipment costs were multiplied by the factors in order to estimate direct construction cost for the purchase and install of the equipment.
- Estimated costs incorporate prevailing King County wage rates.
- All costs were estimated in 1<sup>st</sup> Quarter 2020 dollars.

### **6.0 Allowances**

---

The level and types of allowances used in the estimate is as follows (common percentages for each alternative are shown and any estimate-specific differences are indicated):

- Sales Tax was included as 10.1% applied to the base construction cost, including the design and change order contingencies.
- A 25% Allowance for Indeterminates (AFI) is applied to the base construction cost. The AFI is an allowance that accounts for the cost of known but undefined requirements necessary for a complete and workable project. The AFI accounts for elements that are not explicitly shown in the project documents to be further defined as part of the design development and project delivery process. The AFI is carried at 25% at conceptual design, based on the WTD project delivery process.
- Allowance of 10% for potential construction change orders.
- Allowance of 0.2% of the primary construction amount for miscellaneous direct capital costs.
- Allowance of 0.88% of the primary construction amount for permitting and other agency support.
- Allowance of 1.8% of the primary construction amount for miscellaneous services and material.
- Allowance of 0.65% of the primary construction amount for Non-WTD Support.
- Allowance of 1.0% of the primary construction amount for art initiatives.

## BASIS OF ESTIMATE

Project Name	<b>South Treatment Plant Nitrogen Removal - Alternative 3B</b>		
Project Number:		Date:	March 24, 2020

- Allowance of 0.5% of the total project cost for sustainability.
- Allowance for application of total project contingency (see *Contingency* section below).
- Allowance of 17.44% of the primary construction amount for Engineering Services.
- Allowance of 7.35% of the primary construction amount for Construction Management Support
- Allowance of 12.59% of the primary construction amount for WTD staff labor and burden.
- No Escalation has been included.
- Additional estimating allowances for WTD indirect costs of approximately \$31.38 million have been included in the Total Project Cost estimate by using a moderate degree of complexity rating for Design Engineering, Construction Management, Permitting and Licenses, Operations Support, Community Relations, Project Management, and Project Controls. All other indirect costs were considered routine. Complexity factors were calibrated based on comments received from King County on March 4, 2020.
  - An allowance of \$22.97 million for Design and Construction Consulting
  - An allowance of \$1.16 million for Permitting & Other Agency Support
  - An allowance of \$7.24 million for WTD Staff Labor

### 7.0 Assumptions

---

Any other assumptions made by the estimator but not documented elsewhere in the estimate basis are included in this section.

- All costs included in the estimate reflect the best understanding of requirements as they existed at the time the estimates were prepared. Any modifications to the present scope and/or location of the project site may have substantial cost and schedule impacts.
- The engineering design will be performed by an external consultant engineer.
- Construction management will not be performed “in-house” by WTD. It will be performed by an external consultant construction manager.
- The project will generally align with the WTD PRISM cost model for Treatment projects.
- All work will always be performed utilizing safe work methods.
- Work will be sequenced to minimize standard process, service, and community interruptions. However, no costs are included to address sequencing necessary to keep the plant operational during construction.
- No costs are included for any new facilities that would be required, beyond the scope of this project to replace any lost capacity to the South Treatment Plant.
- It is assumed that the best improvement solution is included in the project scope(s).
- There will be some degree of productivity loss due to the site location. Some degree of productivity loss is included in the estimated costs. Any unusual site conditions are not accounted for in this estimate.

## **BASIS OF ESTIMATE**

Project Name	<b>South Treatment Plant Nitrogen Removal - Alternative 3B</b>		
Project Number:		Date:	March 24, 2020

- Any additional work discovered during project implementation would need to be either a supplemental approval of added scope or be approved as an additional project.
- This project will be engineered to meet Washington State area seismic requirements.
- A degree of minimal cost rounding will occur during the normal estimating process.
- No allowance is included for Material Pricing Uncertainty.
- Power is not readily available in the general area of this project. New power sources are included in the scope of this project.
- It is assumed that some general material contamination is present. The estimate covers minimal cost of removal wherever the contamination is disturbed during construction. This cost is covered in productivity rates utilized in the estimate.

### **8.0 Exclusions**

---

All potential items of cost which might be associated with the project but for which no costs have been included are listed below:

- No asbestos removal costs are included.
- No estimated costs are included for any potential delays due to interferences.
- No costs are included for utility relocations.
- No costs are included for temporary construction easements.
- No costs are included for street use or street improvement permits.
- No costs are included for additional scope beyond that as detailed in the current scope of work.

### **9.0 Exceptions**

---

This estimate is classified as a King County Wastewater Treatment Division Class 5 estimate based on an AACE International Class 5 estimate, with no exceptions per the King County WTD project process, for the scope as known at the time of the estimate preparation.

### **10.0 Risks (Threats and Opportunities)**

---

At the time of estimate preparation, a formal risk analysis session had not been conducted. General potential risks are listed below.

- There is a risk that additional scope, technology advances or major deviation from the suggested project scope will adversely impact cost and schedule.
- Future unknown or changing site conditions present a risk around productivities, schedule, and costs.
- More stringent or completely new regulations, usage fees, permitting, or environmental impacts may result in risks that could adversely impact cost and schedule.
- Potential complex construction and constructability issues could arise during construction, resulting in major design/construction changes.

## **BASIS OF ESTIMATE**

Project Name	<b>South Treatment Plant Nitrogen Removal - Alternative 3B</b>		
Project Number:		Date:	March 24, 2020

- The space constraints could significantly impact assumed productivities and crew sizes identified for the estimated concept, resulting in increased costs due to loss of production.
- The scheduled timing of project execution will greatly impact the bottom-line costs. There is risk related to labor availability and fluctuating commodity and equipment pricing in the timeframe between this early conceptual estimate and the actual execution of the project. Rising costs due to inflation, escalation and competing major worldwide projects pose the possibility of noticeable project cost and schedule increases.
- Weather conditions and emergency service interruptions present the possibility of negative schedule and cost impacts.
- Any possible coordination with other agencies could result in potential impacts on costs, schedule and Project Definition process.
- There is a risk that stakeholders could oppose the proposed design or prefer a different approach or site to be selected, resulting in schedule delays and a higher cost alternative.

### **11.0 Contingency**

---

Contingency is a cost element of the estimate used to cover uncertainties and unforeseeable elements of cost within the defined project scope. Contingency covers inadequacies in project scope definition, estimating methods, and estimating data. Contingency specifically excludes changes in project scope, and unforeseen major events such as earthquakes, prolonged labor strikes, etc.

A 30% Project Contingency was added to the base estimate of Total Project Costs (direct and indirect) as a result of the project estimating process and in accordance with the King County WTD project delivery process.

The estimating analysis resulted in a project contingency of approximately \$140.85 million (US\$).

The total project cost at a 50% confidence level (P50) is typically used for funding and baselining of a project at this stage and level of engineering and project development. The P50 confidence level suggests that there is a 50% cumulative probability of project cost under-run (or 50% probability of exceedance) at this dollar amount for the presently defined and known project scope.

### **12.0 Management Reserve**

---

No allocation of costs was included in this estimate for Management Reserves.

Contingency is not intended to cover the costs for changes in project scope. If the project needs to provide an allowance for anticipated changes in scope or to cover the costs for items that may be required but have not yet been specifically identified as being included in the current project scope, then that amount of cost should be identified here.

### **13.0 Reconciliation**

---

Reconciliation was not conducted at this time.

## **BASIS OF ESTIMATE**

Project Name	<b>South Treatment Plant Nitrogen Removal - Alternative 3B</b>		
Project Number:		Date:	March 24, 2020

### **14.0 Benchmarking**

---

All included Allied Costs as supplied by the PRISM historical database have been benchmarked against a similar portfolio of recently completed projects.

### **15.0 Estimate Quality Assurance Plan**

---

No reviews of total project costs have been conducted outside the reviews conducted within Brown and Caldwell and VMS estimating team. It is anticipated that upon completion of this estimate, reviews will happen between the estimate provider and WTD.

### **16.0 Attachments**

---

#### **Attachment: Estimate Deliverables**

Engineering and Estimating Deliverables provided include:

- Brown and Caldwell Markup, Existing aeration basins 1-4 retrofit assumptions for MLE (Alt 2A/2B/4C)
- Membrane feed pump station wetwell assumptions, undated
- New aeration basin example sketch for MLE (Alt 2A/2B/4C)
- New aeration basin example sketch for 4SMB (Alt 3A/3B/4A)
- Tertiary Feed Pump Station Wetwell sketch, (Alt 2A) and (Alt 4C/4D)
- Brown and Caldwell Layout, STP Nitrogen Removal Study, 9ea. Alternative Marked Up Sketches, undated
- Anammox Cap Cost Assumptions STP, undated
- SP Nitrogen Removal Alt. – Cost Estimating Assumptions, undated
- Velloa, Biostyr HGL drawing package, dated: 02.01.19
- Brown and Caldwell, General Process Arch. Structural drawing package, dated: November 1996
- South Treatment Plant, plant map, dated: June 2016
- Brown and Caldwell, Mechanical, Electrical, Instrumentation drawing package, dated: November 1996
- Brown and Caldwell, General Process and Instrumentation drawing package, dated: October 1993
- Brown and Caldwell, Architectural and Structural drawing package, dated: October 1993
- Brown and Caldwell, Mechanical drawing package, dated: October 1993
- Brown and Caldwell, General Process and Structural drawing package, dated: October 1993
- Brown and Caldwell, Mechanical and Electrical drawing package, dated: October 1993

Equipment Quotes:

- Next Turbo Budget Quote, Aeration Blowers, dated: 10.25.2019
- Suez Budget Quote, MBR, dated: 10.21.2019
- Ovivo Budget Quote, Sidestream Anammox, dated: 09.17.2019
- Biostyr Budget Quote, Tertiary, dated: 10.17.2019



# King County

Department of Natural Resources and Parks  
Wastewater Treatment Division

## Project Planning and Delivery Section

### BASIS OF ESTIMATE

---

Project Name	<b>South Treatment Plant Nitrogen Removal - Alternative 4A</b>
Project Number	
Date Prepared	March 24, 2020
Requested by	Tiffany Knapp, King County WTD
Prepared by	Douglas W. Leo, CCP, CEP, FRICS, FAACE Hon. Life, (VMS, Inc.)
Estimate Classification	WTD Class 5
Estimate Purpose	King County Class 5 Concept Screening
Estimate ID (Version)	6
Project Manager	Eron Jacobson, King County WTD
Project Control Engineer	
Cc or Distribution List	

*Note that the accuracy of the associated cost estimate is dependent upon the various underlying assumptions, inclusions, and exclusions described herein. Actual project costs may differ and can be significantly affected by factors such as changes in the external environment, the manner in which the project is executed and controlled, and other factors that may impact the estimate basis or otherwise affect the project. Estimate accuracy ranges are only assessments based upon the cost estimating methods and data employed in preparing the estimate and are not a guarantee of actual project costs.*

## BASIS OF ESTIMATE

Project Name	<b>South Treatment Plant Nitrogen Removal - Alternative 4A</b>		
Project Number:		Date:	March 24, 2020

### 1.0 Purpose

---

The purpose of this estimate is to provide cost information to support King County's South Treatment Plant (STP) Flows and Loading Alternative Evaluation for the Nitrogen Removal Project. A series of alternatives have been developed for project evaluation to determine the best engineering and project cost solution.

This estimate was prepared to establish a King County Wastewater Treatment Division (WTD) pre-Class 5 conceptual cost estimate to provide order of magnitude cost to support WTD's capital project identification and budgeting process for Total Project Costs. The WTD pre-Class 5 estimate provides similar documentation to that of an AACE International Class 5 estimate. The range of anticipated project costs, per WTD estimating guidance, is -50% / +300%. The range of uncertainty is beyond that for a typical Class 5 estimate due to the scope being proximally defined with today's relative solutions and technologies to resolving the identified needs; when the projects move forward into capital delivery over the longer term, it is anticipated that many differences and changes may arise as the known and defined engineering solutions are developed.

Douglas Leo of Value Management Strategies, Inc. (VMS) prepared this Basis of Estimate in coordination with King County WTD, the Brown and Caldwell Engineers team, and the VMS estimating team after receiving scope information from WTD in October/November 2019 thru February 2020. This Basis of Estimate reflects VMS's best understanding of the estimating process for this project, as explained by King County WTD and Brown and Caldwell.

### 2.0 Project Scope Definition

---

This estimate includes all investigation, administration / owners' costs, engineering and design, purchases, fabrications, installations, process certifications, permitting, community impacts, and miscellaneous costs not specifically excluded elsewhere in this document.

Comprehensive Total Field Costs are generated from historical allowances, sources such as WTD estimating tools, historical costs, and RS Means / VMS estimating databases. All supporting indirect costs were generated from the WTD PRISM historical database. All costs included in the estimate reflect the best understanding of requirements as they existed at the time this estimate was prepared.

The scope of South Treatment Plant Flows and Loading Alternative 3B is to provide Year-Round nitrogen removal (4SMB and Sidestream anammox), with an effluent total inorganic nitrogen (TIN) limit of 3mg/L. The scope was developed to a Conceptual Design level adequate to assess operations and maintenance issues, energy impacts, permitting and code compliance issues, constructability, estimated costs, and implementation schedule.

The Project Estimate was prepared utilizing the following Work Breakdown Structure (WBS) in order to provide clarity and transparency to the estimated costs. The scope as identified for the alternative is described below in accordance with the WBS. Details are based on the known and defined scope in the design documents provided. See section 3.0 for a detailed list of Design Documents.

- A. Primary Effluent (PE)
  - *Not included in the scope for this alternative.*
- B. Aeration Basins
  - New Aeration Basin 1&2 w/baffle walls – purchase / install
  - Interior Cell Walls in New Aeration Basins 1&2
  - Baffle Walls in New Aeration Basins 1&2
  - Baffle Walls in Existing Aeration Basins



## BASIS OF ESTIMATE

Project Name	<b>South Treatment Plant Nitrogen Removal - Alternative 4A</b>		
Project Number:		Date:	March 24, 2020

- Relocate Storage Building
  - Demo Storage Building
  - Relocate Construction Trailers
- C. Membrane Basins
- *Not included in the scope for this alternative*
- D. Internal Mixed Liquor Return (IMLR) Pumping
- IMLR Pumps – purchase/install
  - 36-inch CS Pipe per Aeration Basin
- E. Return Activated Sludge (RAS) Pump
- *Not included in the scope for this alternative*
- F. Sidestream Anammox
- Sidestream Anammox – purchase / install
  - Pumps, Skimmer / Chain / Flight for Sedimentation Tank and Mixers
  - Centrate EQ Tanks
  - Centrate Sedimentation Tank
  - Anammox Reactor Tanks
- G. Supplemental Methanol System
- Supplemental Methanol System 30K gal. – purchase / install
- H. Supplemental Alkalinity System
- Supplemental Alkalinity System 15K gal. – purchase / install
- I. Aeration Blowers
- Aeration Blowers – purchase / install
  - Aeration Blower Diffusers
  - Demolition Allowance
- J. Aeration Basin Mixers for Anoxic Zones
- Aeration Basin Mixers for Anoxic Zones
- K. Sidestream Bioaugmentation
- *Not included in the scope for this alternative*
- L. Tertiary Pumps
- *Not included in the scope for this alternative*
- M. Tertiary Fixed Film System
- *Not included in the scope for this alternative*
- N. Aeration / MBR Odor Control
- *Not included in the scope for this alternative*
- O. Primary Clarifier / Aerated Grit Tank
- *Not included in the scope for this alternative*
- P. Miscellaneous Scope
- ML to Secondary Clarifiers
  - RAS to Aeration Basins
  - PE to Aeration Basins
  - Centrate to Sidestream Anammox

## BASIS OF ESTIMATE

Project Name	<b>South Treatment Plant Nitrogen Removal - Alternative 4A</b>		
Project Number:		Date:	March 24, 2020

- Anammox Effluent to Thickener Overflow Piping
- Alkalinity to RAS Mix Box
- Methanol to Aeration Basin
- Allowance for Upgraded Plant Electrical Power
- Allowance for Flood Control Dike

### 3.0 Design Basis

---

This is an AACE International Class 5 estimate with all required documentation. The estimate is based on engineering deliverables, scoping documentation, discussions with the project team, and all supporting information and documentation provided in October 2019 thru February 2020.

Engineering conceptual scope was provided in the following estimating deliverables. These are the most complete scoping documents that were available to the estimating provider.

Engineering and Estimating Deliverables provided include:

- Brown and Caldwell Markup, Existing aeration basins 1-4 retrofit assumptions for MLE (Alt 2A/2B/4C)
- Membrane feed pump station wetwell assumptions, undated
- New aeration basin example sketch for MLE (Alt 2A/2B/4C)
- New aeration basin example sketch for 4SMB (Alt 3A/3B/4A)
- Tertiary Feed Pump Station Wetwell sketch, (Alt 2A) and (Alt 4C/4D)
- Brown and Caldwell Layout, STP Nitrogen Removal Study, 9ea. Alternative Marked Up Sketches, undated
- Anammox Cap Cost Assumptions STP, undated
- SP Nitrogen Removal Alt. – Cost Estimating Assumptions, undated
- Velloa, Biostyr HGL drawing package, dated: 02.01.19
- Brown and Caldwell, General Process Arch. Structural drawing package, dated: November 1996
- South Treatment Plant, plant map, dated: June 2016
- Brown and Caldwell, Mechanical, Electrical, Instrumentation drawing package, dated: November 1996
- Brown and Caldwell, General Process and Instrumentation drawing package, dated: October 1993
- Brown and Caldwell, Architectural and Structural drawing package, dated: October 1993
- Brown and Caldwell, Mechanical drawing package, dated: October 1993
- Brown and Caldwell, General Process and Structural drawing package, dated: October 1993
- Brown and Caldwell, Mechanical and Electrical drawing package, dated: October 1993

Equipment Quotes:

- Next Turbo Budget Quote, Aeration Blowers, dated: 10.25.2019
- Suez Budget Quote, MBR, dated: 10.21.2019
- Ovivo Budget Quote, Sidestream Anammox, dated: 09.17.2019
- Biostyr Budget Quote, Tertiary, dated: 10.17.2019

## **BASIS OF ESTIMATE**

Project Name	<b>South Treatment Plant Nitrogen Removal - Alternative 4A</b>		
Project Number:		Date:	March 24, 2020

### **4.0 Planning Basis**

---

The following planning basis assumptions were made for the project estimate:

- No project construction plan is in place at this time.
- The assumed execution strategy is a standard workweek with limited overtime.
- No unusual site conditions have been considered as part of this estimate.
- Adequate available power exists at the site.

### **5.0 Cost Basis**

---

- All allied and indirect project costs (allowances for indeterminates, change order allowance, engineering, permitting, WTD staffing, etc.) have been estimated using WTD's PRISM cost model which is baselined to historical project costs.
- The estimate was performed based on drawings, sketches, and project information provided by King County and Brown and Caldwell Engineers.
- WTD is using a PRISM cost model dated January 26, 2017. All Allied and indirect project costs have been estimated using the new WTD PRISM cost model baselined to historical project costs.
- Additional technical project complexity factors for WTD indirect project costs have been introduced and incorporated into project allied costs to allow for development of an additional WTD indirect cost allowance, based upon the unique characteristics of the project.
- Equipment factors were developed utilizing historical data which accounts for specific install of the identified equipment within a normal battery limit. Specific scope relative to this project was used in the equipment factor determination. Factors for each specific type of equipment reflect the different complexity of the installation. Engineering supplied equipment costs were multiplied by the factors in order to estimate direct construction cost for the purchase and install of the equipment.
- Estimated costs incorporate prevailing King County wage rates.
- All costs were estimated in 1<sup>st</sup> Quarter 2020 dollars.

### **6.0 Allowances**

---

The level and types of allowances used in the estimate is as follows (common percentages for each alternative are shown and any estimate-specific differences are indicated):

- Sales Tax was included as 10.1% applied to the base construction cost, including the design and change order contingencies.
- A 25% Allowance for Indeterminates (AFI) is applied to the base construction cost. The AFI is an allowance that accounts for the cost of known but undefined requirements necessary for a complete and workable project. The AFI accounts for elements that are not explicitly shown in the project documents to be further defined as part of the design development and project delivery process. The AFI is carried at 25% at conceptual design, based on the WTD project delivery process.
- Allowance of 10% for potential construction change orders.

## BASIS OF ESTIMATE

Project Name	<b>South Treatment Plant Nitrogen Removal - Alternative 4A</b>		
Project Number:		Date:	March 24, 2020

- Allowance of 0.2% of the primary construction amount for miscellaneous direct capital costs.
- Allowance of 0.88% of the primary construction amount for permitting and other agency support.
- Allowance of 1.8% of the primary construction amount for miscellaneous services and material.
- Allowance of 0.65% of the primary construction amount for Non-WTD Support.
- Allowance of 1.0% of the primary construction amount for art initiatives.
- Allowance of 0.5% of the total project cost for sustainability.
- Allowance for application of total project contingency (see *Contingency* section below).
- Allowance of 16.05% of the primary construction amount for Engineering Services.
- Allowance of 6.56% of the primary construction amount for Construction Management Support
- Allowance of 12.9% of the primary construction amount for WTD staff labor and burden.
- No Escalation has been included.
- Additional estimating allowances for WTD indirect costs of approximately \$52.0 million have been included in the Total Project Cost estimate by using a moderate degree of complexity rating for Design Engineering, Construction Management, Permitting and Licenses, Operations Support, Community Relations, Environmental Planning, Real Estate, Project Management, and Project Controls. Complexity factors were calibrated based on comments received from King County on March 4, 2020.
  - An allowance of \$35.52 million for Design and Construction Consulting
  - An allowance of \$1.97 million for Permitting & Other Agency Support
  - An allowance of \$14.51 million for WTD Staff Labor

### 7.0 Assumptions

---

Any other assumptions made by the estimator but not documented elsewhere in the estimate basis are included in this section.

- All costs included in the estimate reflect the best understanding of requirements as they existed at the time the estimates were prepared. Any modifications to the present scope and/or location of the project site may have substantial cost and schedule impacts.
- The engineering design will be performed by an external consultant engineer.
- Construction management will not be performed ‘in-house’ by WTD. It will be performed by an external consultant construction manager.
- The project will generally align with the WTD PRISM cost model for Treatment projects.
- All work will always be performed utilizing safe work methods.
- Work will be sequenced to minimize standard process, service, and community interruptions. However, no costs are included to address sequencing necessary to keep the plant operational during construction.

## **BASIS OF ESTIMATE**

Project Name	<b>South Treatment Plant Nitrogen Removal - Alternative 4A</b>		
Project Number:		Date:	March 24, 2020

- No costs are included for any new facilities that would be required, beyond the scope of this project to replace any lost capacity to the South Treatment Plant.
- It is assumed that the best improvement solution is included in the project scope(s).
- There will be some degree of productivity loss due to the site location. Some degree of productivity loss is included in the estimated costs. Any unusual site conditions are not accounted for in this estimate.
- Any additional work discovered during project implementation would need to be either a supplemental approval of added scope or be approved as an additional project.
- This project will be engineered to meet Washington State area seismic requirements.
- A degree of minimal cost rounding will occur during the normal estimating process.
- No allowance is included for Material Pricing Uncertainty.
- Power is not readily available in the general area of this project. New power sources are included in the scope of this project.
- It is assumed that some general material contamination is present. The estimate covers minimal cost of removal wherever the contamination is disturbed during construction. This cost is covered in productivity rates utilized in the estimate.

### **8.0 Exclusions**

---

All potential items of cost which might be associated with the project but for which no costs have been included are listed below:

- No asbestos removal costs are included.
- No estimated costs are included for any potential delays due to interferences.
- No costs are included for utility relocations.
- No costs are included for temporary construction easements.
- No costs are included for street use or street improvement permits.
- No costs are included for additional scope beyond that as detailed in the current scope of work.

### **9.0 Exceptions**

---

This estimate is classified as a King County Wastewater Treatment Division Class 5 estimate based on an AACE International Class 5 estimate, with no exceptions per the King County WTD project process, for the scope as known at the time of the estimate preparation.

### **10.0 Risks (Threats and Opportunities)**

---

At the time of estimate preparation, a formal risk analysis session had not been conducted. General potential risks are listed below.

- There is a risk that additional scope, technology advances or major deviation from the suggested project scope will adversely impact cost and schedule.

## BASIS OF ESTIMATE

Project Name	<b>South Treatment Plant Nitrogen Removal - Alternative 4A</b>		
Project Number:		Date:	March 24, 2020

- Future unknown or changing site conditions present a risk around productivities, schedule, and costs.
- More stringent or completely new regulations, usage fees, permitting, or environmental impacts may result in risks that could adversely impact cost and schedule.
- Potential complex construction and constructability issues could arise during construction, resulting in major design/construction changes.
- The space constraints could significantly impact assumed productivities and crew sizes identified for the estimated concept, resulting in increased costs due to loss of production.
- The scheduled timing of project execution will greatly impact the bottom-line costs. There is risk related to labor availability and fluctuating commodity and equipment pricing in the timeframe between this early conceptual estimate and the actual execution of the project. Rising costs due to inflation, escalation and competing major worldwide projects pose the possibility of noticeable project cost and schedule increases.
- Weather conditions and emergency service interruptions present the possibility of negative schedule and cost impacts.
- Any possible coordination with other agencies could result in potential impacts on costs, schedule and Project Definition process.
- There is a risk that stakeholders could oppose the proposed design or prefer a different approach or site to be selected, resulting in schedule delays and a higher cost alternative.

### 11.0 Contingency

---

Contingency is a cost element of the estimate used to cover uncertainties and unforeseeable elements of cost within the defined project scope. Contingency covers inadequacies in project scope definition, estimating methods, and estimating data. Contingency specifically excludes changes in project scope, and unforeseen major events such as earthquakes, prolonged labor strikes, etc.

A 30% Project Contingency was added to the base estimate of Total Project Costs (direct and indirect) as a result of the project estimating process and in accordance with the King County WTD project delivery process.

The estimating analysis resulted in a project contingency of approximately \$235.45 million (US\$).

The total project cost at a 50% confidence level (P50) is typically used for funding and baselining of a project at this stage and level of engineering and project development. The P50 confidence level suggests that there is a 50% cumulative probability of project cost under-run (or 50% probability of exceedance) at this dollar amount for the presently defined and known project scope.

### 12.0 Management Reserve

---

No allocation of costs was included in this estimate for Management Reserves.

Contingency is not intended to cover the costs for changes in project scope. If the project needs to provide an allowance for anticipated changes in scope or to cover the costs for items that may be required but have not yet been specifically identified as being included in the current project scope, then that amount of cost should be identified here.

## **BASIS OF ESTIMATE**

Project Name	<b>South Treatment Plant Nitrogen Removal - Alternative 4A</b>		
Project Number:		Date:	March 24, 2020

### **13.0 Reconciliation**

---

Reconciliation was not conducted at this time.

### **14.0 Benchmarking**

---

All included Allied Costs as supplied by the PRISM historical database have been benchmarked against a similar portfolio of recently completed projects.

### **15.0 Estimate Quality Assurance Plan**

---

No reviews of total project costs have been conducted outside the reviews conducted within Brown and Caldwell and VMS estimating team. It is anticipated that upon completion of this estimate, reviews will happen between the estimate provider and WTD.

### **16.0 Attachments**

---

#### **Attachment: Estimate Deliverables**

Engineering and Estimating Deliverables provided include:

- Brown and Caldwell Markup, Existing aeration basins 1-4 retrofit assumptions for MLE (Alt 2A/2B/4C)
- Membrane feed pump station wetwell assumptions, undated
- New aeration basin example sketch for MLE (Alt 2A/2B/4C)
- New aeration basin example sketch for 4SMB (Alt 3A/3B/4A)
- Tertiary Feed Pump Station Wetwell sketch, (Alt 2A) and (Alt 4C/4D)
- Brown and Caldwell Layout, STP Nitrogen Removal Study, 9ea. Alternative Marked Up Sketches, undated
- Anammox Cap Cost Assumptions STP, undated
- SP Nitrogen Removal Alt. – Cost Estimating Assumptions, undated
- Vello, Biostyr HGL drawing package, dated: 02.01.19
- Brown and Caldwell, General Process Arch. Structural drawing package, dated: November 1996
- South Treatment Plant, plant map, dated: June 2016
- Brown and Caldwell, Mechanical, Electrical, Instrumentation drawing package, dated: November 1996
- Brown and Caldwell, General Process and Instrumentation drawing package, dated: October 1993
- Brown and Caldwell, Architectural and Structural drawing package, dated: October 1993
- Brown and Caldwell, Mechanical drawing package, dated: October 1993
- Brown and Caldwell, General Process and Structural drawing package, dated: October 1993
- Brown and Caldwell, Mechanical and Electrical drawing package, dated: October 1993

Equipment Quotes:

- Next Turbo Budget Quote, Aeration Blowers, dated: 10.25.2019
- Suez Budget Quote, MBR, dated: 10.21.2019



## BASIS OF ESTIMATE

Project Name	<b>South Treatment Plant Nitrogen Removal - Alternative 4A</b>		
Project Number:		Date:	March 24, 2020

- Ovivo Budget Quote, Sidestream Anammox, dated: 09.17.2019
- Biostyr Budget Quote, Tertiary, dated: 10.17.2019



# King County

Department of Natural Resources and Parks  
Wastewater Treatment Division

## Project Planning and Delivery Section

### BASIS OF ESTIMATE

---

Project Name	<b>South Treatment Plant Nitrogen Removal - Alternative 4C</b>
Project Number	
Date Prepared	March 24, 2020
Requested by	Tiffany Knapp, King County WTD
Prepared by	Douglas W. Leo, CCP, CEP, FRICS, FAACE Hon. Life, (VMS, Inc.)
Estimate Classification	WTD Class 5
Estimate Purpose	King County Class 5 Concept Screening
Estimate ID (Version)	6
Project Manager	Eron Jacobson, King County WTD
Project Control Engineer	
Cc or Distribution List	

*Note that the accuracy of the associated cost estimate is dependent upon the various underlying assumptions, inclusions, and exclusions described herein. Actual project costs may differ and can be significantly affected by factors such as changes in the external environment, the manner in which the project is executed and controlled, and other factors that may impact the estimate basis or otherwise affect the project. Estimate accuracy ranges are only assessments based upon the cost estimating methods and data employed in preparing the estimate and are not a guarantee of actual project costs.*

## BASIS OF ESTIMATE

Project Name	<b>South Treatment Plant Nitrogen Removal - Alternative 4C</b>		
Project Number:		Date:	March 24, 2020

### 1.0 Purpose

---

The purpose of this estimate is to provide cost information to support King County's South Treatment Plant (STP) Flows and Loading Alternative Evaluation for the Nitrogen Removal Project. A series of alternatives have been developed for project evaluation to determine the best engineering and project cost solution.

This estimate was prepared to establish a King County Wastewater Treatment Division (WTD) pre-Class 5 conceptual cost estimate to provide order of magnitude cost to support WTD's capital project identification and budgeting process for Total Project Costs. The WTD pre-Class 5 estimate provides similar documentation to that of an AACE International Class 5 estimate. The range of anticipated project costs, per WTD estimating guidance, is -50% / +300%. The range of uncertainty is beyond that for a typical Class 5 estimate due to the scope being proximally defined with today's relative solutions and technologies to resolving the identified needs; when the projects move forward into capital delivery over the longer term, it is anticipated that many differences and changes may arise as the known and defined engineering solutions are developed.

Douglas Leo of Value Management Strategies, Inc. (VMS) prepared this Basis of Estimate in coordination with King County WTD, the Brown and Caldwell Engineers team, and the VMS estimating team after receiving scope information from WTD in October/November 2019 thru February. This Basis of Estimate reflects VMS's best understanding of the estimating process for this project, as explained by King County WTD and Brown and Caldwell.

### 2.0 Project Scope Definition

---

This estimate includes all investigation, administration / owners' costs, engineering and design, purchases, fabrications, installations, process certifications, permitting, community impacts, and miscellaneous costs not specifically excluded elsewhere in this document.

Comprehensive Total Field Costs are generated from historical allowances, sources such as WTD estimating tools, historical costs, and RS Means / VMS estimating databases. All supporting indirect costs were generated from the WTD PRISM historical database. All costs included in the estimate reflect the best understanding of requirements as they existed at the time this estimate was prepared.

The scope of South Treatment Plant Flows and Loading Alternative 4C is to provide Year-Round nitrogen (MLE and Tertiary Denitrifying Fixed Film) removal, effluent total inorganic nitrogen (TIN) limit of 3mg/L. The scope was developed to a Conceptual Design level adequate to assess operations and maintenance issues, energy impacts, permitting and code compliance issues, constructability, estimated costs, and implementation schedule.

The Project Estimate was prepared utilizing the following Work Breakdown Structure (WBS) in order to provide clarity and transparency to the estimated costs. The scope as identified for the alternative is described below in accordance with the WBS. Details are based on the known and defined scope in the design documents provided. See section 3.0 for a detailed list of Design Documents.

- A. Primary Effluent (PE)
  - *Not included in the scope for this alternative.*
- B. Aeration Basins
  - New Aeration Basin – purchase / install
  - Interior Cell Walls in new Aeration Basins
  - Baffle Walls in new Aeration Basins
  - Relocate Storage Building

## BASIS OF ESTIMATE

Project Name	<b>South Treatment Plant Nitrogen Removal - Alternative 4C</b>		
Project Number:		Date:	March 24, 2020

- Demo Storage Building
  - Relocate Construction Trailers
- C. Membrane Basins
- *Not included in the scope for this alternative*
- D. Internal Mixed Liquor Return (IMLR) Pumping
- IMLR Pumps – purchase/install
  - 36-inch CS Pipe per Aeration Basin
- E. Return Activated Sludge (RAS) Pump
- *Not included in the scope for this alternative*
- F. Sidestream Anammox
- *Not included in the scope for this alternative*
- G. Supplemental Methanol System
- Supplemental Methanol System 60K gal. – purchase / install
- H. Supplemental Alkalinity System
- Supplemental Alkalinity System 90K gal. – purchase / install
- I. Aeration Blowers
- Aeration Blowers – purchase / install
  - Aeration Blower Diffusers
  - Demolition Allowance
- J. Aeration Basin Mixers for Anoxic Zones
- Aeration Basin Mixers for Anoxic Zones
- K. Sidestream Bioaugmentation
- *Not included in the scope for this alternative*
- L. Tertiary Pumps
- Tertiary Pumps – purchase / install
  - Tertiary Pumphouse/Electric Building
  - Tertiary Wet Well
  - Tertiary Wet Well Baffle Walls
- M. Tertiary Fixed Film System
- Tertiary Fixed Film System – purchase / install
  - Tertiary Fixed Film Basin
  - Tertiary Fixed Film Basin Interior Walls
- N. Aeration / MBR Odor Control
- *Not included in the scope for this alternative*
- O. Primary Clarifier / Aerated Grit Tank
- *Not included in the scope for this alternative*
- P. Miscellaneous Scope
- Backwash waste to North Primary Distribution System
  - ML to Secondary Clarifiers
  - RAS to Aeration Basins

## BASIS OF ESTIMATE

Project Name	<b>South Treatment Plant Nitrogen Removal - Alternative 4C</b>		
Project Number:		Date:	March 24, 2020

- PE to Aeration Basins
- Tertiary Feed Pump Station Bypass/Overflow
- Tertiary Effluent to New Chlorine Contact Channel
- 66-inch Forced Main
- 144-inch Wet Well Inlet
- Alkalinity to RAS Mix Box
- Methanol to Aeration Basin
- Allowance for Upgraded Plant Electrical Power
- Allowance for Flood Control Dike

### 3.0 Design Basis

---

This is an AACE International Class 5 estimate with all required documentation. The estimate is based on engineering deliverables, scoping documentation, discussions with the project team, and all supporting information and documentation provided in October 2019 thru February 2020.

Engineering conceptual scope was provided in the following estimating deliverables. These are the most complete scoping documents that were available to the estimating provider.

Engineering and Estimating Deliverables provided include:

- Brown and Caldwell Markup, Existing aeration basins 1-4 retrofit assumptions for MLE (Alt 2A/2B/4C)
- Membrane feed pump station wetwell assumptions, undated
- New aeration basin example sketch for MLE (Alt 2A/2B/4C)
- New aeration basin example sketch for 4SMB (Alt 3A/3B/4A)
- Tertiary Feed Pump Station Wetwell sketch, (Alt 2A) and (Alt 4C/4D)
- Brown and Caldwell Layout, STP Nitrogen Removal Study, 9ea. Alternative Marked Up Sketches, undated
- Anammox Cap Cost Assumptions STP, undated
- SP Nitrogen Removal Alt. – Cost Estimating Assumptions, undated
- Velloa, Biostyr HGL drawing package, dated: 02.01.19
- Brown and Caldwell, General Process Arch. Structural drawing package, dated: November 1996
- South Treatment Plant, plant map, dated: June 2016
- Brown and Caldwell, Mechanical, Electrical, Instrumentation drawing package, dated: November 1996
- Brown and Caldwell, General Process and Instrumentation drawing package, dated: October 1993
- Brown and Caldwell, Architectural and Structural drawing package, dated: October 1993
- Brown and Caldwell, Mechanical drawing package, dated: October 1993
- Brown and Caldwell, General Process and Structural drawing package, dated: October 1993
- Brown and Caldwell, Mechanical and Electrical drawing package, dated: October 1993

Equipment Quotes:

- Next Turbo Budget Quote, Aeration Blowers, dated: 10.25.2019
- Suez Budget Quote, MBR, dated: 10.21.2019
- Ovivo Budget Quote, Sidestream Anammox, dated: 09.17.2019
- Biostyr Budget Quote, Tertiary, dated: 10.17.2019

## **BASIS OF ESTIMATE**

Project Name	<b>South Treatment Plant Nitrogen Removal - Alternative 4C</b>		
Project Number:		Date:	March 24, 2020

### **4.0 Planning Basis**

---

The following planning basis assumptions were made for the project estimate:

- No project construction plan is in place at this time.
- The assumed execution strategy is a standard workweek with limited overtime.
- No unusual site conditions have been considered as part of this estimate.
- Adequate available power exists at the site.

### **5.0 Cost Basis**

---

- All allied and indirect project costs (allowances for indeterminates, change order allowance, engineering, permitting, WTD staffing, etc.) have been estimated using WTD's PRISM cost model which is baselined to historical project costs.
- The estimate was performed based on drawings, sketches, and project information provided by King County and Brown and Caldwell Engineers.
- WTD is using a PRISM cost model dated January 26, 2017. All Allied and indirect project costs have been estimated using the new WTD PRISM cost model baselined to historical project costs.
- Additional technical project complexity factors for WTD indirect project costs have been introduced and incorporated into project allied costs to allow for development of an additional WTD indirect cost allowance, based upon the unique characteristics of the project.
- Equipment factors were developed utilizing historical data which accounts for specific install of the identified equipment within a normal battery limit. Specific scope relative to this project was used in the equipment factor determination. Factors for each specific type of equipment reflect the different complexity of the installation. Engineering supplied equipment costs were multiplied by the factors in order to estimate direct construction cost for the purchase and install of the equipment.
- Estimated costs incorporate prevailing King County wage rates.
- All costs were estimated in 1<sup>st</sup> Quarter 2020 dollars.

### **6.0 Allowances**

---

The level and types of allowances used in the estimate is as follows (common percentages for each alternative are shown and any estimate-specific differences are indicated):

- Sales Tax was included as 10.1% applied to the base construction cost, including the design and change order contingencies.
- A 25% Allowance for Indeterminates (AFI) is applied to the base construction cost. The AFI is an allowance that accounts for the cost of known but undefined requirements necessary for a complete and workable project. The AFI accounts for elements that are not explicitly shown in the project documents to be further defined as part of the design development and project delivery

## BASIS OF ESTIMATE

Project Name	<b>South Treatment Plant Nitrogen Removal - Alternative 4C</b>		
Project Number:		Date:	March 24, 2020

process. The AFI is carried at 25% at conceptual design, based on the WTD project delivery process.

- Allowance of 10% for potential construction change orders.
- Allowance of 0.2% of the primary construction amount for miscellaneous direct capital costs.
- Allowance of 0.88% of the primary construction amount for permitting and other agency support.
- Allowance of 1.8% of the primary construction amount for miscellaneous services and material.
- Allowance of 0.65% of the primary construction amount for Non-WTD Support.
- Allowance of 1.0% of the primary construction amount for art initiatives.
- Allowance of 0.5% of the total project cost for sustainability.
- Allowance for application of total project contingency (see *Contingency* section below).
- Allowance of 15.97% of the primary construction amount for Engineering Services.
- Allowance of 6.52% of the primary construction amount for Construction Management Support
- Allowance of 12.87% of the primary construction amount for WTD staff labor and burden.
- No Escalation has been included.
- Additional estimating allowances for WTD indirect costs of approximately \$52.5 million have been included in the Total Project Cost estimate by using a moderate degree of complexity rating for Design Engineering, Construction Management, Permitting and Licenses, Operations Support, Community Relations, Environmental Planning, Real Estate, Project Management, and Project Controls. Complexity factors were calibrated based on comments received from King County on March 4, 2020.
  - An allowance of \$35.85 million for Design and Construction Consulting
  - An allowance of \$1.99 million for Permitting & Other Agency Support
  - An allowance of \$14.67 million for WTD Staff Labor

### 7.0 Assumptions

---

Any other assumptions made by the estimator but not documented elsewhere in the estimate basis are included in this section.

- All costs included in the estimate reflect the best understanding of requirements as they existed at the time the estimates were prepared. Any modifications to the present scope and/or location of the project site may have substantial cost and schedule impacts.
- The engineering design will be performed by an external consultant engineer.
- Construction management will not be performed ‘in-house’ by WTD. It will be performed by an external consultant construction manager.
- The project will generally align with the WTD PRISM cost model for Treatment projects.
- All work will always be performed utilizing safe work methods.



## **BASIS OF ESTIMATE**

Project Name	<b>South Treatment Plant Nitrogen Removal - Alternative 4C</b>		
Project Number:		Date:	March 24, 2020

- Work will be sequenced to minimize standard process, service, and community interruptions. However, no costs are included to address sequencing necessary to keep the plant operational during construction.
- No costs are included for any new facilities that would be required, beyond the scope of this project to replace any lost capacity to the South Treatment Plant.
- It is assumed that the best improvement solution is included in the project scope(s).
- There will be some degree of productivity loss due to the site location. Some degree of productivity loss is included in the estimated costs. Any unusual site conditions are not accounted for in this estimate.
- Any additional work discovered during project implementation would need to be either a supplemental approval of added scope or be approved as an additional project.
- This project will be engineered to meet Washington State area seismic requirements.
- A degree of minimal cost rounding will occur during the normal estimating process.
- No allowance is included for Material Pricing Uncertainty.
- Power is not readily available in the general area of this project. New power sources are included in the scope of this project.
- It is assumed that some general material contamination is present. The estimate covers minimal cost of removal wherever the contamination is disturbed during construction. This cost is covered in productivity rates utilized in the estimate.

### **8.0 Exclusions**

---

All potential items of cost which might be associated with the project but for which no costs have been included are listed below:

- No asbestos removal costs are included.
- No estimated costs are included for any potential delays due to interferences.
- No costs are included for utility relocations.
- No costs are included for temporary construction easements.
- No costs are included for street use or street improvement permits.
- No costs are included for additional scope beyond that as detailed in the current scope of work.

### **9.0 Exceptions**

---

This estimate is classified as a King County Wastewater Treatment Division Class 5 estimate based on an AACE International Class 5 estimate, with no exceptions per the King County WTD project process, for the scope as known at the time of the estimate preparation.

### **10.0 Risks (Threats and Opportunities)**

---

At the time of estimate preparation, a formal risk analysis session had not been conducted. General potential risks are listed below.

## BASIS OF ESTIMATE

Project Name	<b>South Treatment Plant Nitrogen Removal - Alternative 4C</b>		
Project Number:		Date:	March 24, 2020

- There is a risk that additional scope, technology advances or major deviation from the suggested project scope will adversely impact cost and schedule.
- Future unknown or changing site conditions present a risk around productivities, schedule, and costs.
- More stringent or completely new regulations, usage fees, permitting, or environmental impacts may result in risks that could adversely impact cost and schedule.
- Potential complex construction and constructability issues could arise during construction, resulting in major design/construction changes.
- The space constraints could significantly impact assumed productivities and crew sizes identified for the estimated concept, resulting in increased costs due to loss of production.
- The scheduled timing of project execution will greatly impact the bottom-line costs. There is risk related to labor availability and fluctuating commodity and equipment pricing in the timeframe between this early conceptual estimate and the actual execution of the project. Rising costs due to inflation, escalation and competing major worldwide projects pose the possibility of noticeable project cost and schedule increases.
- Weather conditions and emergency service interruptions present the possibility of negative schedule and cost impacts.
- Any possible coordination with other agencies could result in potential impacts on costs, schedule and Project Definition process.
- There is a risk that stakeholders could oppose the proposed design or prefer a different approach or site to be selected, resulting in schedule delays and a higher cost alternative.

### **11.0 Contingency**

---

Contingency is a cost element of the estimate used to cover uncertainties and unforeseeable elements of cost within the defined project scope. Contingency covers inadequacies in project scope definition, estimating methods, and estimating data. Contingency specifically excludes changes in project scope, and unforeseen major events such as earthquakes, prolonged labor strikes, etc.

A 30% Project Contingency was added to the base estimate of Total Project Costs (direct and indirect) as a result of the project estimating process and in accordance with the King County WTD project delivery process.

The estimating analysis resulted in a project contingency of approximately \$238.02 million (US\$).

The total project cost at a 50% confidence level (P50) is typically used for funding and baselining of a project at this stage and level of engineering and project development. The P50 confidence level suggests that there is a 50% cumulative probability of project cost under-run (or 50% probability of exceedance) at this dollar amount for the presently defined and known project scope.

### **12.0 Management Reserve**

---

No allocation of costs was included in this estimate for Management Reserves.

Contingency is not intended to cover the costs for changes in project scope. If the project needs to provide an allowance for anticipated changes in scope or to cover the costs for items that may be required but

## BASIS OF ESTIMATE

Project Name	<b>South Treatment Plant Nitrogen Removal - Alternative 4C</b>		
Project Number:		Date:	March 24, 2020

have not yet been specifically identified as being included in the current project scope, then that amount of cost should be identified here.

### 13.0 Reconciliation

---

Reconciliation was not conducted at this time.

### 14.0 Benchmarking

---

All included Allied Costs as supplied by the PRISM historical database have been benchmarked against a similar portfolio of recently completed projects.

### 15.0 Estimate Quality Assurance Plan

---

No reviews of total project costs have been conducted outside the reviews conducted within Brown and Caldwell and VMS estimating team. It is anticipated that upon completion of this estimate, reviews will happen between the estimate provider and WTD.

### 16.0 Attachments

---

#### Attachment: Estimate Deliverables

Engineering and Estimating Deliverables provided include:

- Brown and Caldwell Markup, Existing aeration basins 1-4 retrofit assumptions for MLE (Alt 2A/2B/4C)
- Membrane feed pump station wetwell assumptions, undated
- New aeration basin example sketch for MLE (Alt 2A/2B/4C)
- New aeration basin example sketch for 4SMB (Alt 3A/3B/4A)
- Tertiary Feed Pump Station Wetwell sketch, (Alt 2A) and (Alt 4C/4D)
- Brown and Caldwell Layout, STP Nitrogen Removal Study, 9ea. Alternative Marked Up Sketches, undated
- Anammox Cap Cost Assumptions STP, undated
- SP Nitrogen Removal Alt. – Cost Estimating Assumptions, undated
- Veloa, Biostyr HGL drawing package, dated: 02.01.19
- Brown and Caldwell, General Process Arch. Structural drawing package, dated: November 1996
- South Treatment Plant, plant map, dated: June 2016
- Brown and Caldwell, Mechanical, Electrical, Instrumentation drawing package, dated: November 1996
- Brown and Caldwell, General Process and Instrumentation drawing package, dated: October 1993
- Brown and Caldwell, Architectural and Structural drawing package, dated: October 1993
- Brown and Caldwell, Mechanical drawing package, dated: October 1993
- Brown and Caldwell, General Process and Structural drawing package, dated: October 1993
- Brown and Caldwell, Mechanical and Electrical drawing package, dated: October 1993

Equipment Quotes:

- Next Turbo Budget Quote, Aeration Blowers, dated: 10.25.2019

## BASIS OF ESTIMATE

Project Name	<b>South Treatment Plant Nitrogen Removal - Alternative 4C</b>		
Project Number:		Date:	March 24, 2020

- Suez Budget Quote, MBR, dated: 10.21.2019
- Ovivo Budget Quote, Sidestream Anammox, dated: 09.17.2019
- Biostyr Budget Quote, Tertiary, dated: 10.17.2019



# King County

Department of Natural Resources and Parks  
Wastewater Treatment Division

## Project Planning and Delivery Section

### BASIS OF ESTIMATE

---

Project Name	<b>South Treatment Plant Nitrogen Removal - Alternative 4D</b>
Project Number	
Date Prepared	March 24, 2020
Requested by	Tiffany Knapp, King County WTD
Prepared by	Douglas W. Leo, CCP, CEP, FRICS, FAACE Hon. Life, (VMS, Inc.)
Estimate Classification	WTD Class 5
Estimate Purpose	King County Class 5 Concept Screening
Estimate ID (Version)	6
Project Manager	Eron Jacobson, King County WTD
Project Control Engineer	
Cc or Distribution List	

*Note that the accuracy of the associated cost estimate is dependent upon the various underlying assumptions, inclusions, and exclusions described herein. Actual project costs may differ and can be significantly affected by factors such as changes in the external environment, the manner in which the project is executed and controlled, and other factors that may impact the estimate basis or otherwise affect the project. Estimate accuracy ranges are only assessments based upon the cost estimating methods and data employed in preparing the estimate and are not a guarantee of actual project costs.*

## BASIS OF ESTIMATE

Project Name	<b>South Treatment Plant Nitrogen Removal - Alternative 4D</b>		
Project Number:		Date:	March 24, 2020

### 1.0 Purpose

---

The purpose of this estimate is to provide cost information to support King County's South Treatment Plant (STP) Flows and Loading Alternative Evaluation for the Nitrogen Removal Project. A series of alternatives have been developed for project evaluation to determine the best engineering and project cost solution.

This estimate was prepared to establish a King County Wastewater Treatment Division (WTD) pre-Class 5 conceptual cost estimate to provide order of magnitude cost to support WTD's capital project identification and budgeting process for Total Project Costs. The WTD pre-Class 5 estimate provides similar documentation to that of an AACE International Class 5 estimate. The range of anticipated project costs, per WTD estimating guidance, is -50% / +300%. The range of uncertainty is beyond that for a typical Class 5 estimate due to the scope being proximally defined with today's relative solutions and technologies to resolving the identified needs; when the projects move forward into capital delivery over the longer term, it is anticipated that many differences and changes may arise as the known and defined engineering solutions are developed.

Douglas Leo of Value Management Strategies, Inc. (VMS) prepared this Basis of Estimate in coordination with King County WTD, the Brown and Caldwell Engineers team, and the VMS estimating team after receiving scope information from WTD in October/November 2019 thru February 2020. This Basis of Estimate reflects VMS's best understanding of the estimating process for this project, as explained by King County WTD and Brown and Caldwell.

### 2.0 Project Scope Definition

---

This estimate includes all investigation, administration/owners' costs, engineering and design, purchases, fabrications, installations, process certifications, permitting, community impacts, and miscellaneous costs not specifically excluded elsewhere in this document.

Comprehensive Total Field Costs are generated from historical allowances, sources such as WTD estimating tools, historical costs, and RS Means/VMS estimating databases. All supporting indirect costs were generated from the WTD PRISM historical database. All costs included in the estimate reflect the best understanding of requirements as they existed at the time this estimate was prepared.

The scope of South Treatment Plant Flows and Loading Alternative 4D is to provide Year-Round nitrogen removal Existing Mainstream and Tertiary Nitrifying/Denitrifying Fixed Film), with an effluent total inorganic nitrogen (TIN) limit of 3mg/L. The scope was developed to a Conceptual Design level adequate to assess operations and maintenance issues, energy impacts, permitting and code compliance issues, constructability, estimated costs, and implementation schedule.

The Project Estimate was prepared utilizing the following Work Breakdown Structure (WBS) in order to provide clarity and transparency to the estimated costs. The scope as identified for the alternative is described below in accordance with the WBS. Details are based on the known and defined scope in the design documents provided. See section 3.0 for a detailed list of Design Documents.

- A. Primary Effluent (PE)
  - *Not included in the scope for this alternative.*
- B. Aeration Basins
  - *Not included in the scope for this alternative.*
- C. Membrane Basins
  - *Not included in the scope for this alternative.*

## BASIS OF ESTIMATE

Project Name	<b>South Treatment Plant Nitrogen Removal - Alternative 4D</b>		
Project Number:		Date:	March 24, 2020



## BASIS OF ESTIMATE

Project Name	<b>South Treatment Plant Nitrogen Removal - Alternative 4D</b>		
Project Number:		Date:	March 24, 2020

- D. Internal Mixed Liquor Return (IMLR) Pumping
  - *Not included in the scope for this alternative.*
- E. Return Activated Sludge (RAS) Pump
  - *Not included in the scope for this alternative*
- F. Sidestream Anammox
  - *Not included in the scope for this alternative*
- G. Supplemental Methanol System
  - Supplemental Methanol System 60K gal. – purchase / install
- H. Supplemental Alkalinity System
  - Supplemental Alkalinity System 90K gal. – purchase /install
- I. Aeration Blowers
  - *Not included in the scope for this alternative.*
- J. Aeration Basin Mixers for Anoxic Zones
  - *Not included in the scope for this alternative.*
- K. Sidestream Bioaugmentation
  - *Not included in the scope for this alternative*
- L. Tertiary Pumps
  - Tertiary Pumps – purchase / install
  - Tertiary Pumphouse/Electric Bldg.
  - Tertiary Wet Well
  - Tertiary Wet Well Baffle Walls
- M. Tertiary Fixed Film System
  - Tertiary Fixed Film System – purchase / install
  - Tertiary Fixed Film Basin 1&2
  - Tertiary Fixed Film Basin Interior Walls 1&2
  - Rebuild Storage Bldg.
  - Demo Storage Bldg.
  - Relocate Construction Trailers
- N. Aeration / MBR Odor Control
  - *Not included in the scope for this alternative*
- O. Primary Clarifier / Aerated Grit Tank
  - *Not included in the scope for this alternative*
- P. Miscellaneous Scope
  - Backwash Waste to North Primary Distribution System
  - Tertiary Feed Pump Station Bypass/Overflow
  - Tertiary Effluent to New Chlorine Contact Channel
  - 66-inch Force Main
  - 144-inch Wet Well Inlet
  - Alkalinity to RAS Mix Box
  - Methanol to Aeration Basin
  - Allowance for Upgraded Plant Electrical Power
  - Allowance for Flood Control Dike

## BASIS OF ESTIMATE

Project Name	<b>South Treatment Plant Nitrogen Removal - Alternative 4D</b>		
Project Number:		Date:	March 24, 2020

### 3.0 Design Basis

---

This is an AACE International Class 5 estimate with all required documentation. The estimate is based on engineering deliverables, scoping documentation, discussions with the project team, and all supporting information and documentation provided in October 2019 thru February 2020.

Engineering conceptual scope was provided in the following estimating deliverables. These are the most complete scoping documents that were available to the estimating provider.

Engineering and Estimating Deliverables provided include:

- Brown and Caldwell Markup, Existing aeration basins 1-4 retrofit assumptions for MLE (Alt 2A/2B/4C)
- Membrane feed pump station wetwell assumptions, undated
- New aeration basin example sketch for MLE (Alt 2A/2B/4C)
- New aeration basin example sketch for 4SMB (Alt 3A/3B/4A)
- Tertiary Feed Pump Station Wetwell sketch, (Alt 2A) and (Alt 4C/4D)
- Brown and Caldwell Layout, STP Nitrogen Removal Study, 9ea. Alternative Marked Up Sketches, undated
- Anammox Cap Cost Assumptions STP, undated
- SP Nitrogen Removal Alt. – Cost Estimating Assumptions, undated
- Velloa, Biostyr HGL drawing package, dated: 02.01.19
- Brown and Caldwell, General Process Arch. Structural drawing package, dated: November 1996
- South Treatment Plant, plant map, dated: June 2016
- Brown and Caldwell, Mechanical, Electrical, Instrumentation drawing package, dated: November 1996
- Brown and Caldwell, General Process and Instrumentation drawing package, dated: October 1993
- Brown and Caldwell, Architectural and Structural drawing package, dated: October 1993
- Brown and Caldwell, Mechanical drawing package, dated: October 1993
- Brown and Caldwell, General Process and Structural drawing package, dated: October 1993
- Brown and Caldwell, Mechanical and Electrical drawing package, dated: October 1993

Equipment Quotes:

- Next Turbo Budget Quote, Aeration Blowers, dated: 10.25.2019
- Suez Budget Quote, MBR, dated: 10.21.2019
- Ovivo Budget Quote, Sidestream Anammox, dated: 09.17.2019
- Biostyr Budget Quote, Tertiary, dated: 10.17.2019

## **BASIS OF ESTIMATE**

Project Name	<b>South Treatment Plant Nitrogen Removal - Alternative 4D</b>		
Project Number:		Date:	March 24, 2020

### **4.0 Planning Basis**

---

The following planning basis assumptions were made for the project estimate:

- No project construction plan is in place at this time.
- The assumed execution strategy is a standard workweek with limited overtime.
- No unusual site conditions have been considered as part of this estimate.
- Adequate available power exists at the site.

### **5.0 Cost Basis**

---

- All allied and indirect project costs (allowances for indeterminates, change order allowance, engineering, permitting, WTD staffing, etc.) have been estimated using WTD's PRISM cost model which is baselined to historical project costs.
- The estimate was performed based on drawings, sketches, and project information provided by King County and Brown and Caldwell Engineers.
- WTD is using a PRISM cost model dated January 26, 2017. All Allied and indirect project costs have been estimated using the new WTD PRISM cost model baselined to historical project costs.
- Additional technical project complexity factors for WTD indirect project costs have been introduced and incorporated into project allied costs to allow for development of an additional WTD indirect cost allowance, based upon the unique characteristics of the project.
- Equipment factors were developed utilizing historical data which accounts for specific install of the identified equipment within a normal battery limit. Specific scope relative to this project was used in the equipment factor determination. Factors for each specific type of equipment reflect the different complexity of the installation. Engineering supplied equipment costs were multiplied by the factors in order to estimate direct construction cost for the purchase and install of the equipment.
- Estimated costs incorporate prevailing King County wage rates.
- All costs were estimated in 1<sup>st</sup> Quarter 2020 dollars.

### **6.0 Allowances**

---

The level and types of allowances used in the estimate is as follows (common percentages for each alternative are shown and any estimate-specific differences are indicated):

- Sales Tax was included as 10.1% applied to the base construction cost, including the design and change order contingencies.
- A 25% Allowance for Indeterminates (AFI) is applied to the base construction cost. The AFI is an allowance that accounts for the cost of known but undefined requirements necessary for a complete and workable project. The AFI accounts for elements that are not explicitly shown in the project documents to be further defined as part of the design development and project delivery process. The AFI is carried at 25% at conceptual design, based on the WTD project delivery process.

## BASIS OF ESTIMATE

Project Name	<b>South Treatment Plant Nitrogen Removal - Alternative 4D</b>		
Project Number:		Date:	March 24, 2020

- Allowance of 10% for potential construction change orders.
- Allowance of 0.2% of the primary construction amount for miscellaneous direct capital costs.
- Allowance of 0.88% of the primary construction amount for permitting and other agency support.
- Allowance of 1.8% of the primary construction amount for miscellaneous services and material.
- Allowance of 0.65% of the primary construction amount for Non-WTD Support.
- Allowance of 1.0% of the primary construction amount for art initiatives.
- Allowance of 0.5% of the total project cost for sustainability.
- Allowance for application of total project contingency (see *Contingency* section below).
- Allowance of 15.74% of the primary construction amount for Engineering Services.
- Allowance of 6.39% of the primary construction amount for Construction Management Support
- Allowance of 12.77% of the primary construction amount for WTD staff labor and burden.
- No Escalation has been included.
- Additional estimating allowances for WTD indirect costs of approximately \$56.7 million have been included in the Total Project Cost estimate by using a moderate degree of complexity rating for Design Engineering, Construction Management, Permitting and Licenses, Operations Support, Community Relations, Environmental Planning, Real Estate, Project Management, and Project Controls. Complexity factors were calibrated based on comments received from King County on March 4, 2020.
  - An allowance of \$38.6 million for Design and Construction Consulting
  - An allowance of \$2.18 million for Permitting & Other Agency Support
  - An allowance of \$15.9 million for WTD Staff Labor

## 7.0 Assumptions

---

Any other assumptions made by the estimator but not documented elsewhere in the estimate basis are included in this section.

- All costs included in the estimate reflect the best understanding of requirements as they existed at the time the estimates were prepared. Any modifications to the present scope and/or location of the project site may have substantial cost and schedule impacts.
- The engineering design will be performed by an external consultant engineer.
- Construction management will not be performed “in-house” by WTD. It will be performed by an external consultant construction manager.
- The project will generally align with the WTD PRISM cost model for Treatment projects.
- All work will always be performed utilizing safe work methods.
- Work will be sequenced to minimize standard process, service, and community interruptions. However, no costs are included to address sequencing necessary to keep the plant operational during construction.

## **BASIS OF ESTIMATE**

Project Name	<b>South Treatment Plant Nitrogen Removal - Alternative 4D</b>		
Project Number:		Date:	March 24, 2020

- No costs are included for any new facilities that would be required, beyond the scope of this project to replace any lost capacity to the South Treatment Plant.
- It is assumed that the best improvement solution is included in the project scope(s).
- There will be some degree of productivity loss due to the site location. Some degree of productivity loss is included in the estimated costs. Any unusual site conditions are not accounted for in this estimate.
- Any additional work discovered during project implementation would need to be either a supplemental approval of added scope or be approved as an additional project.
- This project will be engineered to meet Washington State area seismic requirements.
- A degree of minimal cost rounding will occur during the normal estimating process.
- No allowance is included for Material Pricing Uncertainty.
- Power is not readily available in the general area of this project. New power sources are included in the scope of this project.
- It is assumed that some general material contamination is present. The estimate covers minimal cost of removal wherever the contamination is disturbed during construction. This cost is covered in productivity rates utilized in the estimate.

### **8.0 Exclusions**

---

All potential items of cost which might be associated with the project but for which no costs have been included are listed below:

- No asbestos removal costs are included.
- No estimated costs are included for any potential delays due to interferences.
- No costs are included for utility relocations.
- No costs are included for temporary construction easements.
- No costs are included for street use or street improvement permits.
- No costs are included for additional scope beyond that as detailed in the current scope of work.

### **9.0 Exceptions**

---

This estimate is classified as a King County Wastewater Treatment Division Class 5 estimate based on an AACE International Class 5 estimate, with no exceptions per the King County WTD project process, for the scope as known at the time of the estimate preparation.

### **10.0 Risks (Threats and Opportunities)**

---

At the time of estimate preparation, a formal risk analysis session had not been conducted. General potential risks are listed below.

- There is a risk that additional scope, technology advances or major deviation from the suggested project scope will adversely impact cost and schedule.

## BASIS OF ESTIMATE

Project Name	<b>South Treatment Plant Nitrogen Removal - Alternative 4D</b>		
Project Number:		Date:	March 24, 2020

- Future unknown or changing site conditions present a risk around productivities, schedule, and costs.
- More stringent or completely new regulations, usage fees, permitting, or environmental impacts may result in risks that could adversely impact cost and schedule.
- Potential complex construction and constructability issues could arise during construction, resulting in major design/construction changes.
- The space constraints could significantly impact assumed productivities and crew sizes identified for the estimated concept, resulting in increased costs due to loss of production.
- The scheduled timing of project execution will greatly impact the bottom-line costs. There is risk related to labor availability and fluctuating commodity and equipment pricing in the timeframe between this early conceptual estimate and the actual execution of the project. Rising costs due to inflation, escalation and competing major worldwide projects pose the possibility of noticeable project cost and schedule increases.
- Weather conditions and emergency service interruptions present the possibility of negative schedule and cost impacts.
- Any possible coordination with other agencies could result in potential impacts on costs, schedule and Project Definition process.
- There is a risk that stakeholders could oppose the proposed design or prefer a different approach or site to be selected, resulting in schedule delays and a higher cost alternative.

### 11.0 Contingency

---

Contingency is a cost element of the estimate used to cover uncertainties and unforeseeable elements of cost within the defined project scope. Contingency covers inadequacies in project scope definition, estimating methods, and estimating data. Contingency specifically excludes changes in project scope, and unforeseen major events such as earthquakes, prolonged labor strikes, etc.

A 30% Project Contingency was added to the base estimate of Total Project Costs (direct and indirect) as a result of the project estimating process and in accordance with the King County WTD project delivery process.

The estimating analysis resulted in a project contingency of approximately \$259.47 million (US\$).

The total project cost at a 50% confidence level (P50) is typically used for funding and baselining of a project at this stage and level of engineering and project development. The P50 confidence level suggests that there is a 50% cumulative probability of project cost under-run (or 50% probability of exceedance) at this dollar amount for the presently defined and known project scope.

### 12.0 Management Reserve

---

No allocation of costs was included in this estimate for Management Reserves.

Contingency is not intended to cover the costs for changes in project scope. If the project needs to provide an allowance for anticipated changes in scope or to cover the costs for items that may be required but have not yet been specifically identified as being included in the current project scope, then that amount of cost should be identified here.

## **BASIS OF ESTIMATE**

Project Name	<b>South Treatment Plant Nitrogen Removal - Alternative 4D</b>		
Project Number:		Date:	March 24, 2020

### **13.0 Reconciliation**

---

Reconciliation was not conducted at this time.

### **14.0 Benchmarking**

---

All included Allied Costs as supplied by the PRISM historical database have been benchmarked against a similar portfolio of recently completed projects.

### **15.0 Estimate Quality Assurance Plan**

---

No reviews of total project costs have been conducted outside the reviews conducted within Brown and Caldwell and VMS estimating team. It is anticipated that upon completion of this estimate, reviews will happen between the estimate provider and WTD.

### **16.0 Attachments**

---

#### **Attachment: Estimate Deliverables**

Engineering and Estimating Deliverables provided include:

- Brown and Caldwell Markup, Existing aeration basins 1-4 retrofit assumptions for MLE (Alt 2A/2B/4C)
- Membrane feed pump station wetwell assumptions, undated
- New aeration basin example sketch for MLE (Alt 2A/2B/4C)
- New aeration basin example sketch for 4SMB (Alt 3A/3B/4A)
- Tertiary Feed Pump Station Wetwell sketch, (Alt 2A) and (Alt 4C/4D)
- Brown and Caldwell Layout, STP Nitrogen Removal Study, 9ea. Alternative Marked Up Sketches, undated
- Anammox Cap Cost Assumptions STP, undated
- SP Nitrogen Removal Alt. – Cost Estimating Assumptions, undated
- Veloa, Biostyr HGL drawing package, dated: 02.01.19
- Brown and Caldwell, General Process Arch. Structural drawing package, dated: November 1996
- South Treatment Plant, plant map, dated: June 2016
- Brown and Caldwell, Mechanical, Electrical, Instrumentation drawing package, dated: November 1996
- Brown and Caldwell, General Process and Instrumentation drawing package, dated: October 1993
- Brown and Caldwell, Architectural and Structural drawing package, dated: October 1993
- Brown and Caldwell, Mechanical drawing package, dated: October 1993
- Brown and Caldwell, General Process and Structural drawing package, dated: October 1993
- Brown and Caldwell, Mechanical and Electrical drawing package, dated: October 1993

Equipment Quotes:

- Next Turbo Budget Quote, Aeration Blowers, dated: 10.25.2019
- Suez Budget Quote, MBR, dated: 10.21.2019
- Ovivo Budget Quote, Sidestream Anammox, dated: 09.17.2019
- Biostyr Budget Quote, Tertiary, dated: 10.17.2019





# King County

Department of Natural Resources and Parks  
Wastewater Treatment Division

## Project Planning and Delivery Section

### BASIS OF ESTIMATE

---

Project Name	<b>South Treatment Plant Nitrogen Removal - Alternative 4E</b>
Project Number	
Date Prepared	March 24, 2020
Requested by	Tiffany Knapp, King County WTD
Prepared by	Douglas W. Leo, CCP, CEP, FRICS, FAACE Hon. Life, (VMS, Inc.)
Estimate Classification	WTD Class 5
Estimate Purpose	King County Class 5 Concept Screening
Estimate ID (Version)	6
Project Manager	Eron Jacobson, King County WTD
Project Control Engineer	
Cc or Distribution List	

*Note that the accuracy of the associated cost estimate is dependent upon the various underlying assumptions, inclusions, and exclusions described herein. Actual project costs may differ and can be significantly affected by factors such as changes in the external environment, the manner in which the project is executed and controlled, and other factors that may impact the estimate basis or otherwise affect the project. Estimate accuracy ranges are only assessments based upon the cost estimating methods and data employed in preparing the estimate and are not a guarantee of actual project costs.*

## **BASIS OF ESTIMATE**

Project Name	<b>South Treatment Plant Nitrogen Removal - Alternative 4E</b>		
Project Number:		Date:	March 24, 2020

### **1.0 Purpose**

---

The purpose of this estimate is to provide cost information to support King County's South Treatment Plant (STP) Flows and Loading Alternative Evaluation for the Nitrogen Removal Project. A series of alternatives have been developed for project evaluation to determine the best engineering and project cost solution.

This estimate was prepared to establish a King County Wastewater Treatment Division (WTD) pre-Class 5 conceptual cost estimate to provide order of magnitude cost to support WTD's capital project identification and budgeting process for Total Project Costs. The WTD pre-Class 5 estimate provides similar documentation to that of an AACE International Class 5 estimate. The range of anticipated project costs, per WTD estimating guidance, is -50% / +300%. The range of uncertainty is beyond that for a typical Class 5 estimate due to the scope being proximally defined with today's relative solutions and technologies to resolving the identified needs; when the projects move forward into capital delivery over the longer term, it is anticipated that many differences and changes may arise as the known and defined engineering solutions are developed.

Douglas Leo of Value Management Strategies, Inc. (VMS) prepared this Basis of Estimate in coordination with King County WTD, the Brown and Caldwell Engineers team, and the VMS estimating team after receiving scope information from WTD in October/November 2019 thru February 2020. This Basis of Estimate reflects VMS's best understanding of the estimating process for this project, as explained by King County WTD and Brown and Caldwell.

### **2.0 Project Scope Definition**

---

This estimate includes all investigation, administration / owners' costs, engineering and design, purchases, fabrications, installations, process certifications, permitting, community impacts, and miscellaneous costs not specifically excluded elsewhere in this document.

Comprehensive Total Field Costs are generated from historical allowances, sources such as WTD estimating tools, historical costs, and RS Means / VMS estimating databases. All supporting indirect costs were generated from the WTD PRISM historical database. All costs included in the estimate reflect the best understanding of requirements as they existed at the time this estimate was prepared.

The scope of South Treatment Plant Flows and Loading Alternative 4E is to provide Year-Round nitrogen removal (4SMB/MBR and Sidestream Anammox), with an effluent total inorganic nitrogen (TIN) limit of 3mg/L. The scope was developed to a Conceptual Design level adequate to assess operations and maintenance issues, energy impacts, permitting and code compliance issues, constructability, estimated costs, and implementation schedule.

The Project Estimate was prepared utilizing the following Work Breakdown Structure (WBS) in order to provide clarity and transparency to the estimated costs. The scope as identified for the alternative is described below in accordance with the WBS. Details are based on the known and defined scope in the design documents provided. See section 3.0 for a detailed list of Design Documents.

- A. Primary Effluent (PE)
  - Primary effluent Pump Station
  - Drum Screens
  - New PE Fines Screening Facility
- B. Aeration Basins
  - New Aeration Basin
  - Interior Cell Walls in new Aeration Basin

## BASIS OF ESTIMATE

Project Name	<b>South Treatment Plant Nitrogen Removal - Alternative 4E</b>		
Project Number:		Date:	March 24, 2020

- Baffle Walls in new Aeration Basins
  - Baffle Walls in Existing Aeration Basins
  - New and Existing Aeration Basin Covers and Support Framing
  - Demo and Rebuild Storage Building
  - Relocate Construction Trailers
- C. Membrane Basins
- ISBL Membrane System – purchase/install
  - Membrane Concrete Basin
  - Interior Membrane Basin Walls
  - Membrane Pumphouse / Electrical Bldg.
  - Membrane Feed Pump Station Wetwell
  - Bridge Crane and Rails
  - Demo Clarifiers
- D. Internal Mixed Liquor Return (IMLR) Pumping
- IMLR Pump – purchase/install
  - 36-inch CS Pipe per Aeration Basin
- E. Return Activated Sludge (RAS) Pump
- *Not included in the scope for this alternative*
- F. Sidestream Anammox
- Sidestream Anammox – purchase/install
  - Pumps – install
  - Skimmer, chain, flight for sedimentation tank, mixers
  - Centrate EQ Tank (110K gal.)
  - Centrate Sedimentation Tank (192.3K gal.)
  - Anammox Reactor Tank (500K gal.)
- G. Supplemental Methanol System
- Supplemental Methanol System 30K gal. – purchase / install
- H. Supplemental Alkalinity System
- Supplemental Alkalinity System 15K gal. – purchase / install
- I. Aeration Blowers
- Aeration Blowers – purchase / install
  - Aeration Blower Diffusers
  - Demolition
- J. Aeration Basin Mixers for Anoxic Zones
- Aeration Basin Mixers
- K. Sidestream Bioaugmentation
- *Not included in the scope for this alternative*
- L. Tertiary Pumps
- *Not included in the scope for this alternative*
- M. Tertiary Fixed Film System
- *Not included in the scope for this alternative*
- N. Aeration / MBR Odor Control

## BASIS OF ESTIMATE

Project Name	<b>South Treatment Plant Nitrogen Removal - Alternative 4E</b>		
Project Number:		Date:	March 24, 2020

- *Not included in the scope for this alternative*
- O. Primary Clarifier / Aerated Grit Tank
  - *Not included in the scope for this alternative*
- P. Miscellaneous Scope
  - ML to Membrane Feed Pump House
  - ML to Membrane Basins
  - ML to Secondary Clarifiers
  - RAS to Aeration Basins
  - RAS to existing Clarifier RAS Channel
  - PE to Screening Bldg. Channel
  - PE Pipe to Existing Aeration Basin
  - Centrate to Sidestream Anammox
  - Anammox Effluent to Thickener Overflow Piping
  - Alkalinity to RAS Mix Box
  - Methanol to Aeration Basin
  - Allowance for Upgraded Plant Electrical Power
  - Allowance for Flood Control Dike

### 3.0 Design Basis

---

This is an AACE International Class 5 estimate with all required documentation. The estimate is based on engineering deliverables, scoping documentation, discussions with the project team, and all supporting information and documentation provided in October 2019.

Engineering conceptual scope was provided in the following estimating deliverables. These are the most complete scoping documents that were available to the estimating provider.

Engineering and Estimating Deliverables provided include:

- Brown and Caldwell Markup, Existing aeration basins 1-4 retrofit assumptions for MLE (Alt 2A/2B/4C)
- Membrane feed pump station wetwell assumptions, undated
- New aeration basin example sketch for MLE (Alt 2A/2B/4C)
- New aeration basin example sketch for 4SMB (Alt 3A/3B/4A)
- Tertiary Feed Pump Station Wetwell sketch, (Alt 2A) and (Alt 4C/4D)
- Brown and Caldwell Layout, STP Nitrogen Removal Study, 9ea. Alternative Marked Up Sketches, undated
- Anammox Cap Cost Assumptions STP, undated
- SP Nitrogen Removal Alt. – Cost Estimating Assumptions, undated
- Velloa, Biostyr HGL drawing package, dated: 02.01.19
- Brown and Caldwell, General Process Arch. Structural drawing package, dated: November 1996
- South Treatment Plant, plant map, dated: June 2016
- Brown and Caldwell, Mechanical, Electrical, Instrumentation drawing package, dated: November 1996
- Brown and Caldwell, General Process and Instrumentation drawing package, dated: October 1993
- Brown and Caldwell, Architectural and Structural drawing package, dated: October 1993
- Brown and Caldwell, Mechanical drawing package, dated: October 1993

## **BASIS OF ESTIMATE**

Project Name	<b>South Treatment Plant Nitrogen Removal - Alternative 4E</b>		
Project Number:		Date:	March 24, 2020

- Brown and Caldwell, General Process and Structural drawing package, dated: October 1993
- Brown and Caldwell, Mechanical and Electrical drawing package, dated: October 1993

### Equipment Quotes:

- Next Turbo Budget Quote, Aeration Blowers, dated: 10.25.2019
- Suez Budget Quote, MBR, dated: 10.21.2019
- Ovivo Budget Quote, Sidestream Anammox, dated: 09.17.2019
- Biostyr Budget Quote, Tertiary, dated: 10.17.2019

## **4.0 Planning Basis**

---

The following planning basis assumptions were made for the project estimate:

- No project construction plan is in place at this time.
- The assumed execution strategy is a standard workweek with limited overtime.
- No unusual site conditions have been considered as part of this estimate.
- Adequate available power exists at the site.

## **5.0 Cost Basis**

---

- All allied and indirect project costs (allowances for indeterminates, change order allowance, engineering, permitting, WTD staffing, etc.) have been estimated using WTD's PRISM cost model which is baselined to historical project costs.
- The estimate was performed based on drawings, sketches, and project information provided by King County and Brown and Caldwell Engineers.
- WTD is using a PRISM cost model dated January 26, 2017. All Allied and indirect project costs have been estimated using the new WTD PRISM cost model baselined to historical project costs.
- Additional technical project complexity factors for WTD indirect project costs have been introduced and incorporated into project allied costs to allow for development of an additional WTD indirect cost allowance, based upon the unique characteristics of the project.
- Equipment factors were developed utilizing historical data which accounts for specific install of the identified equipment within a normal battery limit. Specific scope relative to this project was used in the equipment factor determination. Factors for each specific type of equipment reflect the different complexity of the installation. Engineering supplied equipment costs were multiplied by the factors in order to estimate direct construction cost for the purchase and install of the equipment.
- Estimated costs incorporate prevailing King County wage rates.
- All costs were estimated in 2019 dollars.

## BASIS OF ESTIMATE

Project Name	<b>South Treatment Plant Nitrogen Removal - Alternative 4E</b>		
Project Number:		Date:	March 24, 2020

### 6.0 Allowances

---

The level and types of allowances used in the estimate is as follows (common percentages for each alternative are shown and any estimate-specific differences are indicated):

- Sales Tax was included as 10.1% applied to the base construction cost, including the design and change order contingencies.
- A 25% Allowance for Indeterminates (AFI) is applied to the base construction cost. The AFI is an allowance that accounts for the cost of known but undefined requirements necessary for a complete and workable project. The AFI accounts for elements that are not explicitly shown in the project documents to be further defined as part of the design development and project delivery process. The AFI is carried at 25% at conceptual design, based on the WTD project delivery process.
- Allowance of 10% for potential construction change orders.
- Allowance of 0.2% of the primary construction amount for miscellaneous direct capital costs.
- Allowance of 0.88% of the primary construction amount for permitting and other agency support.
- Allowance of 1.8% of the primary construction amount for miscellaneous services and material.
- Allowance of 0.65% of the primary construction amount for Non-WTD Support.
- Allowance of 1.0% of the primary construction amount for art initiatives.
- Allowance of 0.5% of the total project cost for sustainability.
- Allowance for application of total project contingency (see *Contingency* section below).
- Allowance of 19.29% of the primary construction amount for Engineering Services.
- Allowance of 7.22% of the primary construction amount for Construction Management Support
- Allowance of 14.54% of the primary construction amount for WTD staff labor and burden.
- No Escalation has been included.
- Additional estimating allowances for WTD indirect costs of approximately \$168.03 million have been included in the Total Project Cost estimate by using a moderate degree of complexity rating for Permitting and Licenses, Community Relations, Environmental Planning, Real Estate, Project Management, and Project Controls. A high degree of complexity rating for Design Engineering, Construction Management and Operation Support has been included. Complexity factors were calibrated based on comments received from King County on March 4, 2020.
  - An allowance of \$123.97 million for Design and Construction Consulting
  - An allowance of \$3.77 million for Permitting & Other Agency Support
  - An allowance of \$40.29 million for WTD Staff Labor

### 7.0 Assumptions

---

Any other assumptions made by the estimator but not documented elsewhere in the estimate basis are included in this section.

## BASIS OF ESTIMATE

Project Name	<b>South Treatment Plant Nitrogen Removal - Alternative 4E</b>		
Project Number:		Date:	March 24, 2020

- All costs included in the estimate reflect the best understanding of requirements as they existed at the time the estimates were prepared. Any modifications to the present scope and/or location of the project site may have substantial cost and schedule impacts.
- The engineering design will be performed by an external consultant engineer.
- Construction management will not be performed “in-house” by WTD. It will be performed by an external consultant construction manager.
- The project will generally align with the WTD PRISM cost model for Treatment projects.
- All work will always be performed utilizing safe work methods.
- Work will be sequenced to minimize standard process, service, and community interruptions. However, no costs are included to address sequencing necessary to keep the plant operational during construction.
- No costs are included for any new facilities that would be required, beyond the scope of this project to replace any lost capacity to the South Treatment Plant.
- It is assumed that the best improvement solution is included in the project scope(s).
- There will be some degree of productivity loss due to the site location. Some degree of productivity loss is included in the estimated costs. Any unusual site conditions are not accounted for in this estimate.
- Any additional work discovered during project implementation would need to be either a supplemental approval of added scope or be approved as an additional project.
- This project will be engineered to meet Washington State area seismic requirements.
- A degree of minimal cost rounding will occur during the normal estimating process.
- No allowance is included for Material Pricing Uncertainty.
- Power is not readily available in the general area of this project. New power sources are included in the scope of this project.
- It is assumed that some general material contamination is present. The estimate covers minimal cost of removal wherever the contamination is disturbed during construction. This cost is covered in productivity rates utilized in the estimate.

### 8.0 Exclusions

---

All potential items of cost which might be associated with the project but for which no costs have been included are listed below:

- No asbestos removal costs are included.
- No estimated costs are included for any potential delays due to interferences.
- No costs are included for utility relocations.
- No costs are included for temporary construction easements.
- No costs are included for street use or street improvement permits.
- No costs are included for additional scope beyond that as detailed in the current scope of work.



## BASIS OF ESTIMATE

Project Name	<b>South Treatment Plant Nitrogen Removal - Alternative 4E</b>		
Project Number:		Date:	March 24, 2020

### 9.0 Exceptions

---

This estimate is classified as a King County Wastewater Treatment Division Class 5 estimate based on an AACE International Class 5 estimate, with no exceptions per the King County WTD project process, for the scope as known at the time of the estimate preparation.

### 10.0 Risks (Threats and Opportunities)

---

At the time of estimate preparation, a formal risk analysis session had not been conducted. General potential risks are listed below.

- There is a risk that additional scope, technology advances or major deviation from the suggested project scope will adversely impact cost and schedule.
- Future unknown or changing site conditions present a risk around productivities, schedule, and costs.
- More stringent or completely new regulations, usage fees, permitting, or environmental impacts may result in risks that could adversely impact cost and schedule.
- Potential complex construction and constructability issues could arise during construction, resulting in major design/construction changes.
- The space constraints could significantly impact assumed productivities and crew sizes identified for the estimated concept, resulting in increased costs due to loss of production.
- The scheduled timing of project execution will greatly impact the bottom-line costs. There is risk related to labor availability and fluctuating commodity and equipment pricing in the timeframe between this early conceptual estimate and the actual execution of the project. Rising costs due to inflation, escalation and competing major worldwide projects pose the possibility of noticeable project cost and schedule increases.
- Weather conditions and emergency service interruptions present the possibility of negative schedule and cost impacts.
- Any possible coordination with other agencies could result in potential impacts on costs, schedule and Project Definition process.
- There is a risk that stakeholders could oppose the proposed design or prefer a different approach or site to be selected, resulting in schedule delays and a higher cost alternative.

## **BASIS OF ESTIMATE**

Project Name	<b>South Treatment Plant Nitrogen Removal - Alternative 4E</b>		
Project Number:		Date:	March 24, 2020

### **11.0 Contingency**

---

Contingency is a cost element of the estimate used to cover uncertainties and unforeseeable elements of cost within the defined project scope. Contingency covers inadequacies in project scope definition, estimating methods, and estimating data. Contingency specifically excludes changes in project scope, and unforeseen major events such as earthquakes, prolonged labor strikes, etc.

A 30% Project Contingency was added to the base estimate of Total Project Costs (direct and indirect) as a result of the project estimating process and in accordance with the King County WTD project delivery process.

The estimating analysis resulted in a project contingency of approximately \$468.29 million (US\$).

The total project cost at a 50% confidence level (P50) is typically used for funding and baselining of a project at this stage and level of engineering and project development. The P50 confidence level suggests that there is a 50% cumulative probability of project cost under-run (or 50% probability of exceedance) at this dollar amount for the presently defined and known project scope.

### **12.0 Management Reserve**

---

No allocation of costs was included in this estimate for Management Reserves.

Contingency is not intended to cover the costs for changes in project scope. If the project needs to provide an allowance for anticipated changes in scope or to cover the costs for items that may be required but have not yet been specifically identified as being included in the current project scope, then that amount of cost should be identified here.

### **13.0 Reconciliation**

---

Reconciliation was not conducted at this time.

### **14.0 Benchmarking**

---

All included Allied Costs as supplied by the PRISM historical database have been benchmarked against a similar portfolio of recently completed projects.

### **15.0 Estimate Quality Assurance Plan**

---

No reviews of total project costs have been conducted outside the reviews conducted within Brown and Caldwell and VMS estimating team. It is anticipated that upon completion of this estimate, reviews will happen between the estimate provider and WTD.

### **16.0 Attachments**

---

#### **Attachment: Estimate Deliverables**

Engineering and Estimating Deliverables provided include:

- Brown and Caldwell Markup, Existing aeration basins 1-4 retrofit assumptions for MLE (Alt 2A/2B/4C)

## BASIS OF ESTIMATE

Project Name	<b>South Treatment Plant Nitrogen Removal - Alternative 4E</b>		
Project Number:		Date:	March 24, 2020

- Membrane feed pump station wetwell assumptions, undated
- New aeration basin example sketch for MLE (Alt 2A/2B/4C)
- New aeration basin example sketch for 4SMB (Alt 3A/3B/4A)
- Tertiary Feed Pump Station Wetwell sketch, (Alt 2A) and (Alt 4C/4D)
- Brown and Caldwell Layout, STP Nitrogen Removal Study, 9ea. Alternative Marked Up Sketches, undated
- Anammox Cap Cost Assumptions STP, undated
- SP Nitrogen Removal Alt. – Cost Estimating Assumptions, undated
- Velloa, Biostyr HGL drawing package, dated: 02.01.19
- Brown and Caldwell, General Process Arch. Structural drawing package, dated: November 1996
- South Treatment Plant, plant map, dated: June 2016
- Brown and Caldwell, Mechanical, Electrical, Instrumentation drawing package, dated: November 1996
- Brown and Caldwell, General Process and Instrumentation drawing package, dated: October 1993
- Brown and Caldwell, Architectural and Structural drawing package, dated: October 1993
- Brown and Caldwell, Mechanical drawing package, dated: October 1993
- Brown and Caldwell, General Process and Structural drawing package, dated: October 1993
- Brown and Caldwell, Mechanical and Electrical drawing package, dated: October 1993

### Equipment Quotes:

- Next Turbo Budget Quote, Aeration Blowers, dated: 10.25.2019
- Suez Budget Quote, MBR, dated: 10.21.2019
- Ovivo Budget Quote, Sidestream Anammox, dated: 09.17.2019
- Biostyr Budget Quote, Tertiary, dated: 10.17.2019

## **Attachment D: Budgetary Proposals for Equipment**

---



# Project Quotation



Projectname: King County South Plant  
Projectnumber: 193679  
Date: 10/25/2019

More info on <http://www.next-turbo.com>



## 1. Scope of Delivery

### Summary

#### Project Details

Project:	King County South Plant – <b>2A</b>
Compressor type:	GTH-T50-XY
Compressor Control :	Discharge Diffuser & Inlet Guide vane control
Motor Size:	1000 HP, rated at 60 Hz, 4160 V
Number of Units:	3
Max. Power at design conditions:	881.3 HP
Air volume turndown:	40-100%
Discharge temperature (a):	206 °F (worst case scenario)
Max Air speed discharge	3923 ft/min with NPS28
Design inlet air temperature:	90°F at 50%rH
Design airflow:	16566 SCFM at 14.7 PSIA, 68°F, 36% rH 17516 ACFM at 14.7 PSIA, 90°F, 50% rH
Design differential pressure:	11.5 PSIG
<b>BUDGET PRICE (3 UNITS)</b>	<b>\$1,400,000</b>

#### Project Details

Project:	King County South Plant – <b>1A</b>
Compressor type:	GTH-T50-XY
Compressor Control :	Discharge Diffuser & Inlet Guide vane control
Motor Size:	1250 HP, rated at 60 Hz, 4160 V
Number of Units:	3
Max. Power at design conditions:	1026 HP
Air volume turndown:	40-100%
Discharge temperature (a):	206 °F (worst case scenario)
Max Air speed discharge	3370 ft/min with NPS28
Design inlet air temperature:	90°F at 50%rH
Design airflow:	19366 SCFM at 14.7 PSIA, 68°F, 36% rH 20476 ACFM at 14.7 PSIA, 90°F, 50% rH
Design differential pressure:	11.5 PSIG
<b>BUDGET PRICE (3 UNITS)</b>	<b>\$1,460,000</b>

## Project Details

Project:	King County South Plant – <b>1A</b>
Compressor type:	GTH-T50-XY
Compressor Control :	Discharge Diffuser & Inlet Guide vane control
Motor Size:	1250 HP, rated at 60 Hz, 4160 V
Number of Units:	4
Max. Power at design conditions:	1186.4 HP
Air volume turndown:	40-100%
Discharge temperature (a):	206 °F (worst case scenario)
Max Air speed discharge	3911 ft/min with NPS28
Design inlet air temperature:	90°F at 50%rH
Design airflow:	22475 SCFM at 14.7 PSIA, 68°F, 36% rH 23763 ACFM at 14.7 PSIA, 90°F, 50% rH
Design differential pressure:	11.5 PSIG
<b>BUDGET PRICE (3 UNITS)</b>	<b>\$1,950,000</b>

## Project Details

Project:	King County South Plant – <b>3B and 4A</b>
Compressor type:	GTH-T50-XY
Compressor Control :	Discharge Diffuser & Inlet Guide vane control
Motor Size:	1500 HP, rated at 60 Hz, 4160 V
Number of Units:	4
Max. Power at design conditions:	1320.8 HP
Air volume turndown:	40-100%
Discharge temperature (a):	206 °F (worst case scenario)
Max Air speed discharge	3340 ft/min with NPS32
Design inlet air temperature:	90°F at 50%rH
Design airflow:	25075 SCFM at 14.7 PSIA, 68°F, 36% rH 26512 ACFM at 14.7 PSIA, 90°F, 50% rH
Design differential pressure:	11.5 PSIG
<b>BUDGET PRICE (3 UNITS)</b>	<b>\$2,260,000</b>



## Project Details

Project:	King County South Plant – <span style="background-color: green; color: black;">11</span>
Compressor type:	GTH-T50-XY
Compressor Control :	Discharge Diffuser & Inlet Guide vane control
Motor Size:	1500 HP, rated at 60 Hz, 4160 V
Number of Units:	4
Max. Power at design conditions:	1220.7 HP
Air volume turndown:	40-100%
Discharge temperature (a):	206 °F (worst case scenario)
Max Air speed discharge	3084 ft/min with NPS32
Design inlet air temperature:	90°F at 50%rH
Design airflow:	23150 SCFM at 14.7 PSIA, 68°F, 36% rH 24477 ACFM at 14.7 PSIA, 90°F, 50% rH
Design differential pressure:	11.5 PSIG
<b>BUDGET PRICE (3 UNITS)</b>	<b>\$2,260,000</b>

## Project Details

Project:	King County South Plant – <span style="background-color: green; color: black;">11</span>
Compressor type:	GTH-T50-XY
Compressor Control :	Discharge Diffuser & Inlet Guide vane control
Motor Size:	1750 HP, rated at 60 Hz, 4160 V
Number of Units:	2
Max. Power at design conditions:	1415.8 HP
Air volume turndown:	40-100%
Discharge temperature (a):	206 °F (worst case scenario)
Max Air speed discharge	3584 ft/min with NPS32
Design inlet air temperature:	90°F at 50%rH
Design airflow:	26900 SCFM at 14.7 PSIA, 68°F, 36% rH 28442 ACFM at 14.7 PSIA, 90°F, 50% rH
Design differential pressure:	11.5 PSIG
<b>BUDGET PRICE (3 UNITS)</b>	<b>\$1,150,000</b> (this can be met with a greater quantity of smaller blowers, if desired)

## Scope Selection base offer

ID	Item	Type/size	Included
1.	Geared Turbocompressor	GTH-T50-XY	✓
5.	Softstarter (MCC)		
6.	Inlet silencer/filter		✓
7.	Flexible Compensator		✓
8.	Discharge diffuser		✓
9.	Blow-off valve/ silencer		✓
10.	Checkvalve		✓
11.	Electrical drive motor - B3		✓
12.	Isolation valve (electrical)		✓
13.	Silencer blocks/ mounts		✓
14.	Local Control panel		✓



Item included in base offer  
 Item offered as an option

# of blowers needed for peak hour airflow	Alternative	Max month airflow (scfm)	Peak hour airflow (scfm)
3	2A	31,100	49,700
3	2B	36,300	58,100
4	3A	56,200	89,900
4	3B	63,500	100,300
4	4A	62,700	100,300
4	4C	57,900	92,600
2	4E	33,600	53,800

## Terms and Conditions

---

<b>Delivery time</b>	5/6 months – from factory order acceptance, Kansas City (MO) USA
<b>Delivery</b>	FOB Kansas City (MO) – Incoterms 2010
<b>Conditions</b>	See attached Terms & Conditions
<b>Payment plan</b>	<ul style="list-style-type: none"> <li>▪ 25% down payment with contract signature, net 30 days from invoice</li> <li>▪ 45% with purchasing of major parts such as motor/ gearbox; net 30 days from invoice</li> <li>▪ 20% at successful mechanical test; net 30 days from invoice</li> <li>▪ 10% at successful onsite commissioning, however not longer than 3 month after delivery, net 30 days from invoice</li> </ul>
<b>Offer Validity</b>	6 months from offer date – non binding for supplier
<b>Warranty</b>	24 months from start up, however not longer than 30 from delivery or supplier readiness notification
<b>Conservation</b>	Before shipping, compressors will be preserved for storage up to 6 months
<b>Packing</b>	
<b>Lubricants</b>	First lube oil filling is included
<b>Manuals</b>	All electronic files in English language are included in 1 CD/DVD.
<b>Documentation</b>	See attached list
<b>Mechanical test</b>	All compressors are mechanically tested before delivery, with issue of a test certificate.
<b>Quality &amp; tests</b>	See attached Inspection & Testing Plan (ITP)

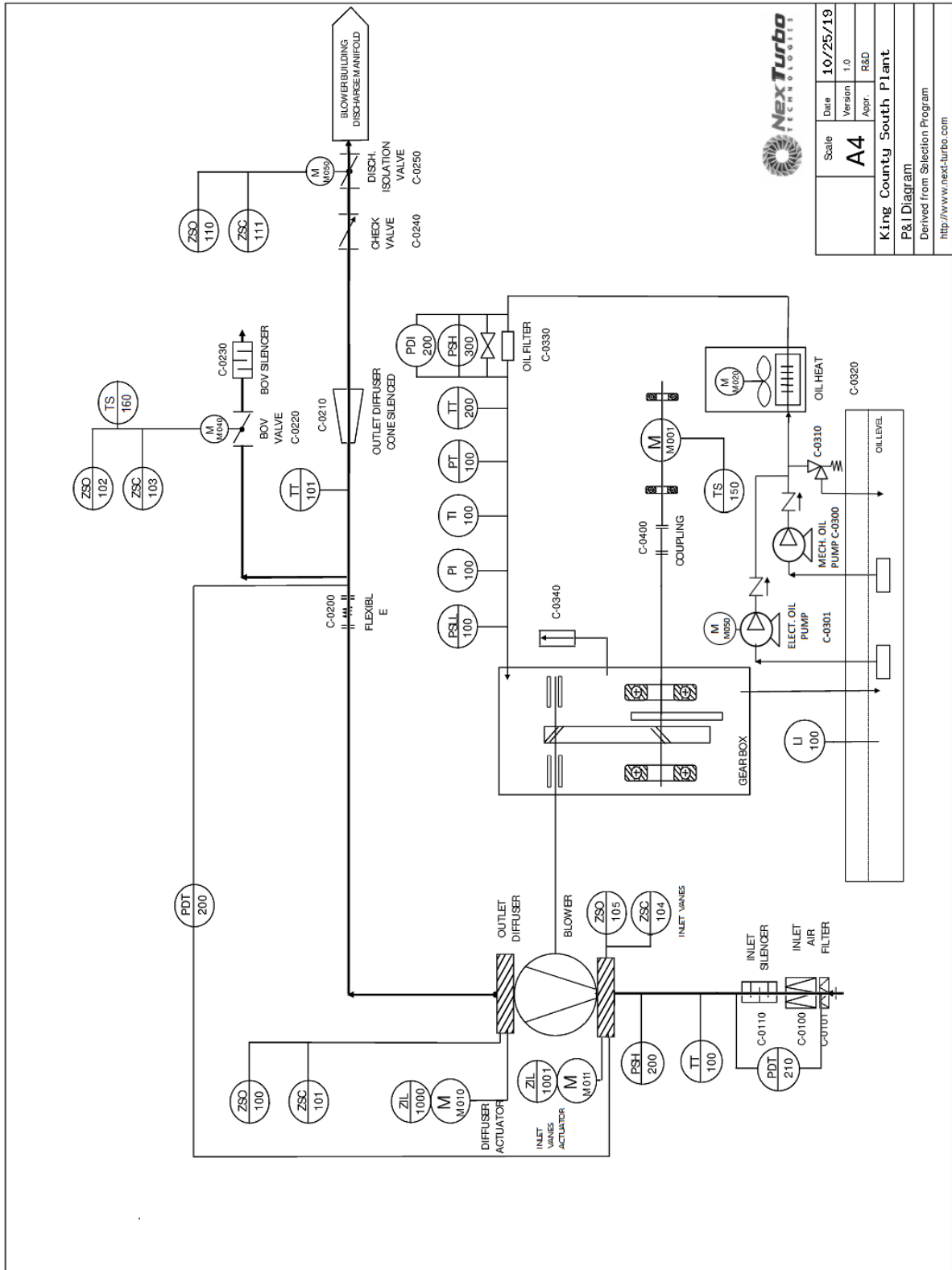

Scale	Date
<b>A4</b>	10/25/19
	Version
	1.0
	Apr.
	R&D
<b>King County South Plant</b>	
<b>P&amp;I Diagram</b>	
Derived from Selection Program	
<a href="http://www.next-turbo.com">http://www.next-turbo.com</a>	



## Technical documents

# Oil Specification

Specification of lubricating oil applicable for compressors with anti-friction bearings (ball/roller bearings).

Compressor	Oil Type acc. DIN51502	Viscosity Index (min) acc. ISO2909	Viscosity min at 120 C	FZG STAGE min. DIN51354
GTH-T50	PAO	137	4.20	10

PAO = Synthetic oil, polyalfaolifine

## Suppliers

The following suppliers and oil types are recommended.

Company	Oil type
TOTAL	DACNIS SH 46
SHELL	MADRELA AS 46
<b>MOBIL</b>	<b>MOBIL SHC 624</b>
Q8	Q8 SCHUMANN 32
STATOIL	COMPWAY SX 32
ESSO	ESSO COMPRESSOR OIL RS32
TRIBOL	TRIBOL 1550/32
KLEBER	KLEBER SYNTH GEM 4-32
FUCHS	FUCHS COFRABAR P32

# Standard Surface Treatment

## Compressor Unit

---

Surfaces of compressor and equipment excl. armatures, all galvanized parts and stainless Supplier parts.  
Corrosion class of paint supplier: C3 according to ISO 12944. Suitable for temperatures up to 120°C.

### 1.1 Pre-Treatment

Cleaning by sand-blasting to obtain metallic radiance of surface according to ISO 8501-1, quality: SA 2 ½. If sand-blasting is not possible: Mechanical cleaning according to ISO 8501-01, quality ST3

### 1.2 Primer

2 x Corrosion protective primer, two component epoxy basis, wet-in-wet application. Product manufacturer: PPG Univer S.p.A, type: Epoxy primer H<sub>2</sub>O

Type of bond: Epoxy

Pigmentation: organic and inorganic pigments and anticorrosive pigments

Film thickness: min. 40 - 50 micro meter Dry film thickness (DFT)

Color: grey / RAL 7035

If the primer film is thinner than 40 micrometer, or if spots of corrosion are visible, or the adhesion is insufficient, the area must be cleansed again to ST3, and a new coating of primer must be applied.

### 1.3 Finishing Coat

2 x Top coat, two component epoxy. Product manufacturer: TECNA PPG Univer S.p.A, type: Tecnodur H<sub>2</sub>O

Type of bond: epoxy resins

Film thickness: min. 60 - 70 micro meter Dry film thickness (DFT)

Color: RAL 5015 (sky blue)

Total film thickness (primer + finishing coat): min. 100, max 130 micrometer Dry film thickness (DFT)

## Electric Motors

---

Motors are coated as per manufacturer standards.

Primer: 20 microns (DFT)

Finish: 50 microns (DFT)

Total film thickness: min. 70 micrometer Dry film thickness (DFT)

Color: RAL 5015 (sky blue)





Water Technologies & Solutions

budget proposal for the  
**King County South Treatment Plant**  
ZeeWeed\* membrane system

**submitted to:**

**Brown and Caldwell**

701 Pike St., Suite 1200  
Seattle, Washington, 98101

attention: Matt Winkler, P.E.

**October 21, 2019**

**proposal number: 380466 – revision 0**

**submitted by:**

Chris Allen, P.E. - Regional Manager  
(503) 307-2238  
chris.allen@suez.com

**local representation by:**

**APSCO**

Joe Kernkamp  
(206) 890-4039  
jkernkamp@apsco-llc.com

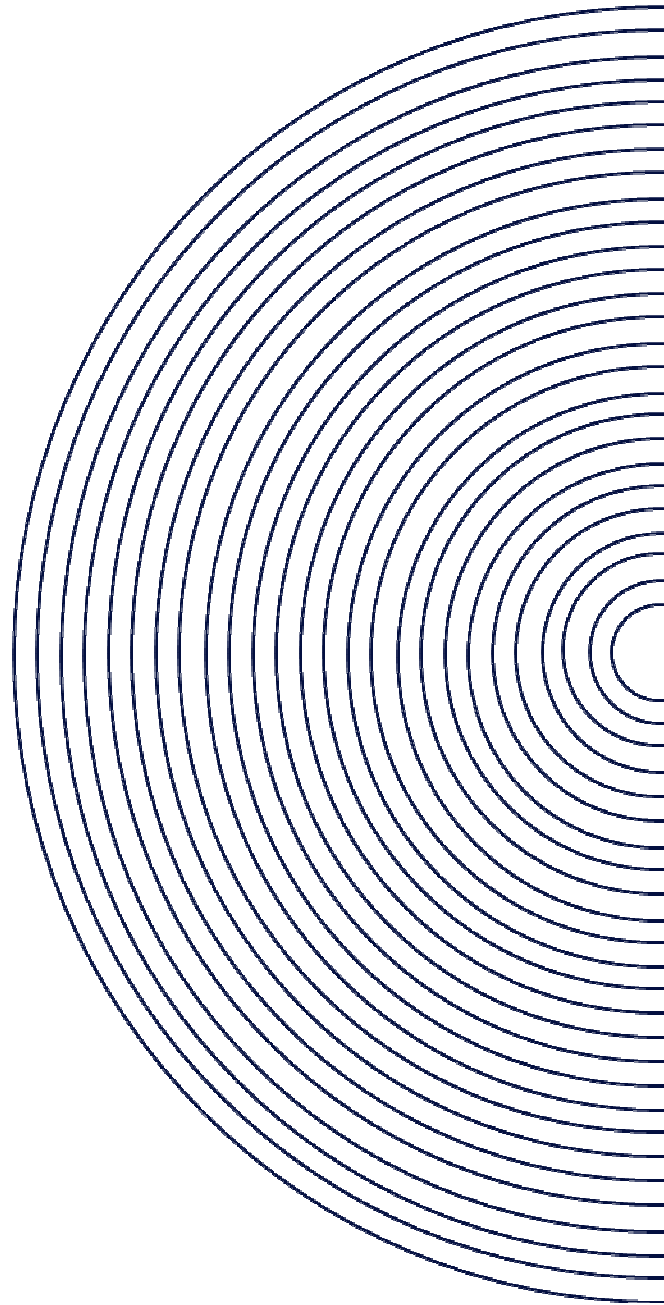

## table of contents

<b>1</b>	<b>basis of design</b> .....	<b>3</b>
1.1	influent flow data .....	3
1.2	influent quality .....	3
1.3	influent variability.....	4
1.4	effluent quality .....	4
<b>2</b>	<b>system design and scope</b> .....	<b>5</b>
2.1	ultrafiltration system design.....	6
2.2	estimated membrane scour airflow .....	7
2.3	scope of supply by SUEZ .....	7
<b>3</b>	<b>buyer scope of supply</b> .....	<b>10</b>
<b>4</b>	<b>commercial</b> .....	<b>12</b>
4.1	pricing .....	12
4.2	annual chemical consumption estimate .....	12
4.3	equipment shipment and delivery.....	13
4.4	freight terms .....	13
4.5	terms and conditions of sale.....	13

### **SUEZ Water Technologies & Solutions confidential and proprietary information**

The enclosed materials are considered proprietary property of SUEZ Water Technologies & Solutions (SUEZ). No assignments either implied or expressed, of intellectual property rights, data, know-how, trade secrets or licenses of use thereof are given. All information is provided exclusively to the addressee and agents of the addressee for the purposes of evaluation and is not to be reproduced or divulged to other parties, nor used for manufacture or other means, without the express written consent of SUEZ. The acceptance of this document will be construed as an acceptance of the foregoing.

\*The following are trademarks of SUEZ Water Technologies & Solutions and may be registered in one or more countries: InSight, LEAPmbr, LEAPprimary, Z-MOD, ZeeWeed, and ZENON

# 1 basis of design

The following membrane system design for the MBR retrofit at King County South Treatment Plant located in Renton, Washington is offered based on the design parameters below provided by Brown and Caldwell.

## 1.1 influent flow data

The influent design conditions are summarized in the tables below.

<b>alternative 4E</b>		
minimum average day flow (min ADF)	76.5	mgd
average day flow (ADF)	97.9	mgd
maximum month flow (MMF)	144	mgd
maximum day flow (MDF)	287	mgd
maximum flow with one train offline for maintenance or cleaning (for 24 hours)	287	mgd

- min ADF - the average flow rate occurring over a 24-hour period during summer months.
- ADF – the average flow rate occurring over a 24-hour period based on annual flow rate data.
- MMF – the average flow rate occurring over a 24-hour period during the 30-day period with the highest flow based on annual flow rate data.
- MDF – the average flow rate occurring over a 24-hour period occurring within annual flow rate data.

## 1.2 influent quality

Below are the ultrafiltration system influent characteristics that were used for this design; any deviation from the values below may impact the membrane system design.

<b>properties of mixed liquor entering membrane tanks</b>	<b>acceptable operating range</b>
Temperature range (°C)	13.1 – 21.5
MLSS concentration in membrane tanks (mg/L)	≤ 12,000 <sup>1</sup>
pH (SU)	6.5 – 7.5
soluble cBOD <sub>5</sub> concentration (mg/L)	≤ 5
NH <sub>3</sub> -N concentration (mg/L)	≤ 1.0
colloidal TOC (cTOC) concentration (mg/L) <sup>2</sup>	≤ 10
soluble alkalinity (mg/L as CaCO <sub>3</sub> )	50 – 150
time to filter (TTF) <sup>3</sup>	≤ 200
material greater than 2 mm in size (mg/L) <sup>4</sup>	≤ 1

note 1: Membrane tank MLSS concentration of up to 12,000 mg/L is permissible during MDF and PHF events only. Membrane tanks MLSS concentration to be ≤10,000 mg/L during all other flow conditions. There is no minimum concentration requirement.

note 2: Colloidal TOC (cTOC) is the difference between the TOC measured in the filtrate passing through a 1.5-µm filter paper and the TOC measured in the ZeeWeed membrane permeate.

note 3: Per seller’s standard time to filter (TTF) procedure (available upon request).

note 4: Per seller’s standard sieve test procedure (available upon request).

note 5: Chemicals that are not compatible with the ZeeWeed PVDF membrane are not permitted in the membrane tanks.

### 1.3 influent variability

Influent wastewater flows or loads in excess of the design criteria defined above will be bypassed.

### 1.4 effluent quality

The following performance parameters are expected based on the data listed in sections 1.1 and 1.2.

TSS	≤ 1	mg/L
turbidity	≤ 0.5 (100% of time) ≤ 0.2 (95% of time)	NTU

## 2 system design and scope

The membrane bioreactor (MBR) process consists of a suspended growth biological reactor integrated with a membrane filtration system, using the ZeeWeed hollow fiber ultrafiltration membrane. SUEZ is providing only the membrane filtration system design in this proposal, while the biological design is by others. The membrane filtration system essentially replaces the solids separation function of secondary clarifiers and tertiary sand filters used in a conventional activated sludge process.

ZeeWeed ultrafiltration membranes are directly immersed in mixed liquor. Using a permeate pump, a vacuum is applied to a header pipe connected to the membranes. The vacuum draws the treated water through the hollow fiber membranes. Permeate is then directed to downstream disinfection or discharge facilities. Air, in the form of large bubbles, is introduced below the bottom of the membrane modules, producing turbulence that scours the outer surface of the hollow fibers to keep them clean.

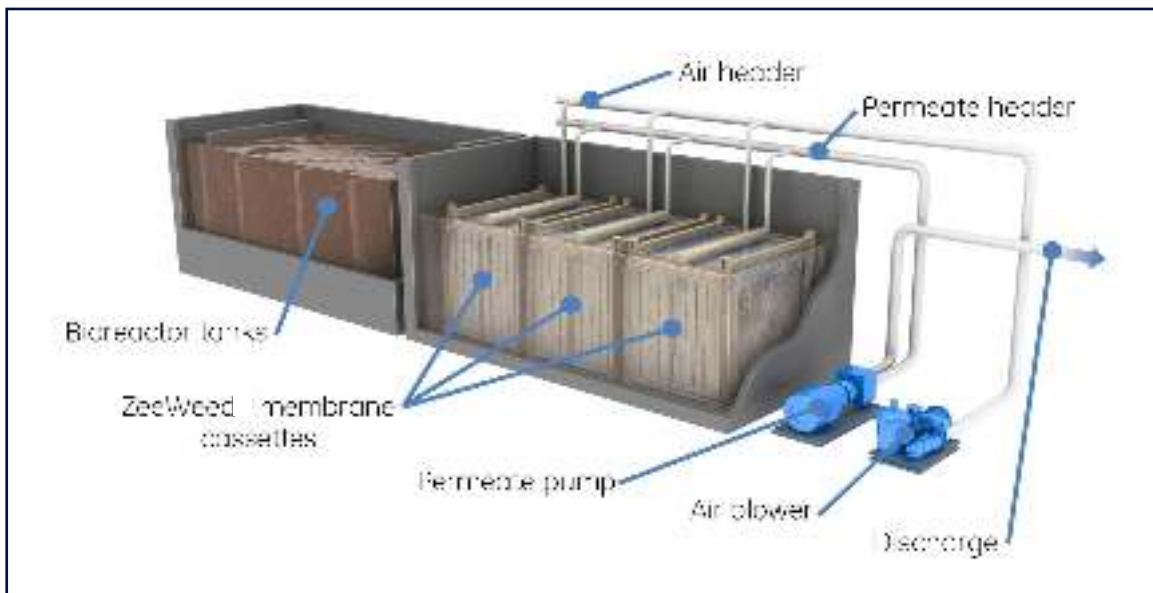

The proposed MBR design utilizes LEAPmbr, SUEZ’s latest technology for wastewater treatment. The use of LEAPmbr offers some of the most important benefits of a ZeeWeed MBR systems – simplicity, reliability, and lowest life-cycle cost.

### simplicity

Over the years, SUEZ has continually improved the design of ZeeWeed MBR systems, making them the simplest MBR systems in the industry to operate and maintain. The membrane filtration system for the King County South Treatment Plant MBR is fully automated, with operators having the ability to review operation, adjust set points, or schedule operating tasks through the easy-to-understand HMI graphical display.

**A fully automated suite of membrane maintenance procedures** will ensure long-term, successful operation, including:

- in situ chemical membrane cleaning performed directly in the membrane tanks so your operators don't waste time moving cassettes;
- the ability to increase or decrease the frequency of maintenance cleans to fit the operating conditions;
- the ability to backpulse when needed to greatly improve your operator's ability to recover from non-design conditions.

The above cleaning systems are automated resulting in operators having available a full suite of comprehensive cleaning systems which are simple to use and initiate.

### reliability

SUEZ's reinforced ZeeWeed hollow fiber membrane incorporates a patented internal support to which the membrane is bonded, creating the most robust membrane in the industry. In addition, SUEZ's automated manufacturing processes ensure a consistent membrane product meeting the highest standards of workmanship and quality. This exceptionally strong and reliable membrane forms the backbone of ZeeWeed MBR systems, which consistently exceeds the toughest regulatory standards around the world.

SUEZ is the world leader in MBR technology, with the majority of the industry's largest and longest-operating MBR plants. SUEZ now has over two decades of experience with the well-proven ZeeWeed membrane. The earliest MBR plants using the ZeeWeed 500 membrane, SUEZ's current standard for MBR applications, have now been in operation for over 10 years. SUEZ's long-term and wide-ranging MBR experience ensures that plant operators can count on many years of successful operation of the proposed ZeeWeed MBR plant.

### lowest lifecycle cost

LEAPmbr aeration is a significant innovation for ZeeWeed MBR technology that offers a 30% reduction in air flow versus SUEZ's previous air cycling technology. When combined with LEAPmbr's other features, membrane aeration energy savings are almost 50% compared with the previous generation of ZeeWeed membranes. In addition to the substantial energy savings, LEAPmbr requires fewer membrane modules and cassettes, smaller membrane tanks, fewer valves and pipes, and lower connected horsepower. In many cases, a ZeeWeed MBR system using LEAPmbr technology has an equivalent lifecycle cost to conventional treatment options.

## 2.1 ultrafiltration system design

The table below outlines two possible designs for the King County South Treatment Plant. These designs were developed based on the available information received from Brown & Caldwell and are subject to change pending more detailed information. Ultimately, SUEZ would work alongside King County and B&C engineers to determine the best possible design for the King County South Treatment Plant. Our system can be designed in many configurations, utilizing larger or smaller train sizes to fit the site space requirements as needed.

The membrane designs shown in the table below are for the flux cap of 10 gfd, while the other is for SUEZ's standard design flux.

flux	design flux <sup>1</sup>	10 gfd
number of membrane trains	24	54
number of cassette spaces per train	32	32
number of rows of cassettes per train	2	2
number of cassettes installed per train	28	28
type of cassette (number of modules)	52	52
module design per train	26 x 52 + 2 x 40 + 4 x 0	26 x 52 + 2 x 40 + 4 x 0
total number of modules installed per train	1,432	1,432
total number of modules installed per plant	34,368	77,328
membrane surface area	12,716,160 ft <sup>2</sup>	28,611,360 ft <sup>2</sup>
Total volume displaced by membranes	298,992 gal	674,676 gal
total number of cassettes installed per plant	672	1,512
spare space	13.9 %	13.9 %
membrane tank internal dimensions (L x W x H) <sup>2</sup>	103.3 x 20 x 13 ft	103.3 x 20 x 13 ft
total membrane tank volume <sup>2</sup>	4,821,548 gal	10,848,483 gal

note 1: based on SUEZ's standard design flux for the ZeeWeed 500d membrane at 13C.

note 2: Tank dimensions and volumes are preliminary only and may change once final detail design commences.

note 3: The ultrafiltration system is designed for installation within concrete tanks supplied by buyer.

## 2.2 estimated membrane scour airflow

The table below contains estimates for the require membrane scour air flow for each condition. Air flow requirements are based on ADF flow conditions.

<del>alternative 4E</del>	<del>72,648 scfm</del>
alternative 4E – 10 gfd flux cap	163,458 scfm

## 2.3 scope of supply by SUEZ

SUEZ's scope of supply for a ZeeWeed 500 membrane wastewater treatment system, for the King County South Treatment Plant project is as follows.

- Electrical rating on all motors is 460V / 3ph / 60 Hz. Large motors may require higher voltage. Single phase power requirement is 120V.
- All proposed equipment and instrumentation quoted is to be installed in a NFPA 820 non-classified area.



- All devices will be SUEZ standard devices and the proposed equipment will be supplied to SUEZ specifications.
- Equipment will be **supplied loose-shipped** unless otherwise noted.

#### ZeeWeed membranes and associated equipment

- ZeeWeed 500 membrane cassettes and modules
- membrane tank cassette mounting assemblies
- permeate collection & air distribution header pipes
- membrane tank level transmitters, one per membrane tank
- membrane tank level switches, one set per tank

#### process pumping system

- permeate pumps supplied loose, complete with required isolation valves, pressure gauges, and flow meters, one set per membrane train
- vacuum ejectors and associated valves, one per membrane train
- pressure transmitters for measure of transmembrane pressure, one per membrane train
- turbidimeters, one per membrane train

#### membrane air scour blowers

- common membrane air scour blowers supplied loose, complete with required isolation valves, pressure gauges and flow switches and acoustic enclosures

#### backpulse system

- backpulse pumps supplied loose, complete with required isolation valves, check valves, switches and flow meter

#### mixed liquor recirculation (if required)

- mixed liquor recirculation pumps used to transfer mixed liquor from membrane tanks to bioreactor, supplied loose, complete with required isolation valves and check valves, pressure gauges, and flow meters

#### membrane cleaning systems

- sodium hypochlorite chemical feed system
- citric acid chemical feed system

#### electrical and control equipment

- master control panel containing PLC and touch screen HMI

#### miscellaneous

- air compressors and refrigerated air dryers for ejectors and pneumatic valves operation

**general**

- equipment layout, membrane tank general arrangement and process and instrumentation drawings
- operating & maintenance manuals
- field service and start-up assistance - 200 days support from SUEZ water field-service personnel for installation assistance, commissioning, plant start-up and operator training
- membrane warranty – 2 years
- equipment mechanical warranty – 1 year or 18 months from shipment of equipment
- InSight Pro – process consulting service and 24/7 emergency telephone technical support service – 1 year

### 3 buyer scope of supply

The following items are for supply by buyer and will include but are not limited to:

- overall plant design responsibility
- review and approval of design parameters related to the membrane separation system
- review and approval of SUEZ-supplied tank and equipment drawings and specifications
- detail drawings of all termination points where SUEZ equipment or materials tie into equipment or materials supplied by buyer
- design, supply and installation of lifting devices including overhead traveling bridge crane and/or monorail able to lift 4,535 kg (10,000 lb) for membrane removal, lifting davits c/w a hoist, guide rails for submersible mixers and pumps etc.
- civil works, provision of main plant tank structure, buildings, equipment foundation pads etc. including but not limited to:
  - common channels, housekeeping pads, equipment access platforms, walkways, handrails, stairs, etc.
- membrane tanks, tank covers or grating, and their support over membrane tanks.
- HVAC equipment design, specifications and installation (where applicable)
- UPS, power conditioner, emergency power supply and specification (where applicable)
- 2-mm pre-treatment fine screens
- biological process equipment – including process blowers, diffusers and mixers
- VFDs and MCC for all SUEZ supplied equipment
- plant SCADA system
- process and utilities piping, pipe supports, hangers, valves, etc. including but not limited to:
  - piping, pipe supports and valves between SUEZ-supplied equipment and other plant process equipment
  - piping between any loose-supplied SUEZ equipment
  - process tank aeration system air piping, equalization tank system piping, etc.
- electrical wiring, conduit and other appurtenances required to provide power connections as required from the electrical power source to the SUEZ control panel and from the control panel to any electrical equipment, pump motors and instruments external to the SUEZ-supplied enclosure

- supply and installation of suitable, secure remote internet connection for 24/7 emergency telephone technical support service and InSight remote monitoring & diagnostics service
- design, supply and installation of equipment anchor bolts and fasteners for SUEZ supplied equipment. All seismic structural analysis and anchor bolt sizing.
- receiving (confirmation versus packing list), unloading and safe storage of SUEZ-supplied equipment at site until ready for installation
- installation on site of all SUEZ supplied loose-shipped equipment
- alignment of rotating equipment
- raw materials, chemicals, and utilities during equipment start-up and operation
- disposal of initial start-up wastewater and associated chemicals
- supply of seed sludge for biological process start-up purposes
- laboratory services, operating and maintenance personnel during equipment checkout, start-up and operation
- touch up primer and finish paint surfaces on equipment as required at the completion of the project
- weather protection as required for all SUEZ-supplied equipment. Skids and electrical panels are designed for indoor operation and will need shelter from the elements.

## 4 commercial

### 4.1 pricing

Pricing for the proposed equipment and services, as outlined in section 2.3, is summarized in the table below. All pricing is based on the design operating conditions and influent characteristics detailed in section 1. The pricing herein is for budgetary purposes only and does not constitute an offer of sale. No sales, consumer use or other similar taxes or duties are included in the pricing below.

<b>price: all equipment &amp; service (all pricing in USD)</b>	
<del>alternative 4E</del>	<del>\$ 80,683,000</del>
alternative 4E – 10 gfd flux cap	\$ 111,254,000

### 4.2 annual chemical consumption estimate

	<b>US gal/year</b>
<del><b>alternative 4E</b></del>	
<del>sodium hypochlorite (10.3% w/w, SG: 1.168)</del>	<del>158,923</del>
<del>citric acid (50.0% w/w, SG: 1.24)</del>	<del>18,872</del>
<b>alternative 4E – 10 gfd flux cap</b>	
sodium hypochlorite (10.3% w/w, SG: 1.168)	357,577
citric acid (50.0% w/w, SG: 1.24)	42,462

note 1: Cleaning chemical consumption estimates are based on the frequencies and concentrations summarized in the table below. Frequencies are typical for ZW-MBR operation, actual frequency of maintenance and recovery cleans may change with final design or may change once system is in operation.

#### basis of chemical consumption estimates

<b>chemical</b>		<b>maintenance clean</b>	<b>recovery clean</b>
sodium hypochlorite solution (10.3% w/w, SG: 1.168)	frequency	2 times per week	2 times per year
	concentration	200 mg/L	1,000 mg/L
citric acid solution (50.0% w/w, SG: 1.24)	frequency	n/a	2 times per year
	concentration	n/a	2,000 mg/L

### 4.3 equipment shipment and delivery

Equipment shipment is estimated at 28 to 37 weeks after order acceptance. The buyer and seller will arrange a kick-off meeting after contract acceptance to develop a firm shipment schedule.

#### typical drawing submission and equipment shipment schedule

	8-12 weeks	2-3 weeks	16-20 weeks	2 weeks
acceptance of PO				
submission of drawings				
drawings approval				
equipment manufacturing				
equipment shipment				
plant operations manuals				

The delivery schedule is presented based on current workload backlogs and production capacity. This estimated delivery schedule assumes no more than 2 weeks for buyer review of submittal drawings. Any delays in buyer approvals or requested changes may result in additional charges and/or a delay to the schedule.

### 4.4 freight terms

The following freight terms used are as defined by INCOTERMS 2010.

All pricing is CIP to King County South Treatment Plant project site.

### 4.5 terms and conditions of sale

This proposal has been prepared and is submitted based on seller’s standard terms and conditions of sale.

## KING COUNTY SOUTH WWTP, WA

### AnammoPAQ® System

### PREPARED FOR

---

**Brown and Caldwell**

Matt Winkler

[mwinkler@brwncald.com](mailto:mwinkler@brwncald.com)

### AREA REPRESENTATIVE

---

**Goble Sampson**

Douglas Allie

[dallie@goblesampson.com](mailto:dallie@goblesampson.com)

### PREPARED BY

Mudit Gangal

Phone: (512)-834-6042

[mudit.gangal@ovivowater.com](mailto:mudit.gangal@ovivowater.com)

**Ovivo USA, LLC**

2404 Rutland Drive

Austin, Texas, 78758, USA





September 17, 2019

Attn: Mr. Matt Winkler  
Brown and Caldwell

Re: King County South WWTP, WA  
Ovivo AnammoPAQ® System  
Proposal No. 091719-1-MG-R0

Dear Mr. Winkler,

With regard to your recent request for the King County South WWTP, WA, Ovivo USA, LLC is pleased to submit this preliminary proposal for its AnammoPAQ® system. The system design is based on the influent high nitrogen stream at the King County South WWTP, WA having a design (Peak Month) flow of 0.66 MGD (1 MGD Peak Day flow) to achieve approximately 80% Ammonia-N removal.

It is assumed that the dewatering will occur 24 hours a day and 7 days a week with AnammoPAQ® system operation 7 days a week. It is also assumed enough equalization (and dilution water for peak day scenario) will be provided (by others) and all equipment in the equalization tank including feed pumps will be by others.

We have endeavored to provide complete information in this proposal. However, if you have any questions or need additional information, please feel free to contact Doug our regional sales representative, or me directly.

Sincerely,

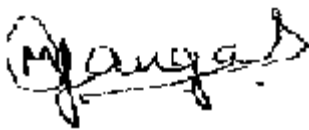

**Mudrit Gangal**  
Product Group Manager  
Biosolids Management and Resource Recovery  
Ovivo USA, LLC  
2404 Rutland Drive, Austin, Texas 78758  
P: 512-834-6042 C: 512-590-0391 F: 512-834-6039



## INTRODUCTION

The King County South WWTP, WA is in the process of evaluating technologies for treatment of its high Nitrogen content side-stream to reduce the Ammonia-N load to help meet its effluent permits in an efficient manner. The design flows and loads required to be treated by using the AnammoPAQ<sup>®</sup> treatment process to reduce the Ammonia-N concentration in the effluent stream being discharged to more acceptable limits are provided in Table 1 below.

## BASIS OF DESIGN

The AnammoPAQ<sup>®</sup> system design and performance are based on the design information provided by Brown and Caldwell. Table 1 summarizes the parameters used for developing the proposed solution.

Treatment Parameter	Units	Peak Month	Peak Day	Treated Effluent
Equalized Design Flow	MGD	0.66	1.0	
Temperature	°C	25-30	25-30	
TKN	mg/l	1,456	1,456	
NH <sub>3</sub> -N	mg/l	1,354	1,354	< 271
Alkalinity	mg/l	4,239	4,239	
TP	mg/l	< 90	< 90	
TSS	mg/l	< 500	< 500	
BOD	mg/l	< 200	< 200	
COD	mg/l	< 800	< 800	
pH		7-8	7-8	

The design is based on the following assumption(s):

- The influent flows are produced seven (7) days a week, twenty-four (24) hours a day.
- Given the high influent TP and COD, it is recommended to have pre-treatment (by others) to ensure optimal process performance. Suggested pre-treatment system for the above is the Ovivo-Paques PhospaQ<sup>™</sup> system for which we would be happy to provide information on upon request.
- Dilution water (up to 250,000 gpd) will be provided (by others) for Peak Day conditions

© Copyright 2019 OVIVO. All rights reserved.

This document is confidential and shall remain the sole property of Ovivo. This document may not be reproduced or distributed without prior written approval of Ovivo. The data and information provided is furnished on a restricted basis and is not to be used in any way detrimental to the interests of Ovivo

THIS BUDGETARY PROPOSAL CONSTITUTES A NON-BINDING ESTIMATE OF PRICE(S) FOR CERTAIN GOODS AND/OR SERVICES THAT MAY BE PROVIDED BY OVIVO USA LLC FROM TIME TO TIME, BUT SHALL NOT BE CONSTRUED AS A CONTRACTUAL OFFER FOR OVIVO USA LLC TO PROVIDE SUCH GOODS AND/OR SERVICES. ANY CONTRACTUAL OFFER FOR THE SUPPLY OF GOODS AND/OR SERVICES BY OVIVO USA LLC SHALL BE CONVEYED TO CUSTOMER IN THE FORM OF OVIVO USA LLC'S STANDARD PROPOSAL DOCUMENT, WHICH INCLUDES, BUT IS NOT LIMITED TO, ITS STANDARD TERMS AND CONDITIONS OF SALE. SUCH PROPOSAL FORM MAY BE PROVIDED TO CUSTOMER UPON REQUEST.

The King County South WWTP, WA AnammoPAQ<sup>®</sup> system was designed using extensive modeling and experience from Ovivo's pilot and full-scale installations. The modeling assists in process selection and determining the optimal volumes for treatment and the overall process operating parameters.

## OVIVO-PAQUES ANAMMOPAQ<sup>®</sup> EXPERIENCE

The Ovivo-Paques AnammoPAQ<sup>®</sup> system currently has over 50 operating nitrogen removal deammonification systems worldwide including North America. Further, Ovivo's AnammoPAQ<sup>®</sup> installation base cumulatively treats globally Nitrogen loads in excess of 250,000 lbs N/d, which is second to none. This is estimated to be around 80% of all Ammonia-N load currently treated in engineered systems utilizing anammox bacteria worldwide.



**Figure:1 Modular AnammoPAQ<sup>®</sup> setup at Rendac, The Netherland (13,000 lds N/day)**

**© Copyright 2019 OVIVO. All rights reserved.**

This document is confidential and shall remain the sole property of Ovivo. This document may not be reproduced or distributed without prior written approval of Ovivo. The data and information provided is furnished on a restricted basis and is not to be used in any way detrimental to the interests of Ovivo

THIS BUDGETARY PROPOSAL CONSTITUTES A NON-BINDING ESTIMATE OF PRICE(S) FOR CERTAIN GOODS AND/OR SERVICES THAT MAY BE PROVIDED BY OVIVO USA LLC FROM TIME TO TIME, BUT SHALL NOT BE CONSTRUED AS A CONTRACTUAL OFFER FOR OVIVO USA LLC TO PROVIDE SUCH GOODS AND/OR SERVICES. ANY CONTRACTUAL OFFER FOR THE SUPPLY OF GOODS AND/OR SERVICES BY OVIVO USA LLC SHALL BE CONVEYED TO CUSTOMER IN THE FORM OF OVIVO USA LLC'S STANDARD PROPOSAL DOCUMENT, WHICH INCLUDES, BUT IS NOT LIMITED TO, ITS STANDARD TERMS AND CONDITIONS OF SALE. SUCH PROPOSAL FORM MAY BE PROVIDED TO CUSTOMER UPON REQUEST.

## TREATMENT APPROACH

In the AnammoPAQ<sup>®</sup> reactor, ammonium is converted to nitrogen gas. The reaction is executed by two different bacteria, which coexist in the reactor. Ammonium oxidizing bacteria (AOB) oxidize about half of the ammonium to nitrite. Anammox bacteria then convert the remaining ammonium and nitrite, into nitrogen gas. The overall reaction of the one step AnammoPAQ<sup>®</sup> reactor is:

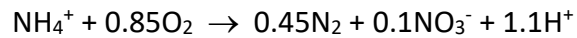

The deammonification conversion thus is an elegant shortcut in the natural nitrogen cycle. A key feature of the AnammoPAQ<sup>®</sup> system is that ammonium is removed from the reject water stream in one treatment step without the use of external carbon sources and with minimal energy input.

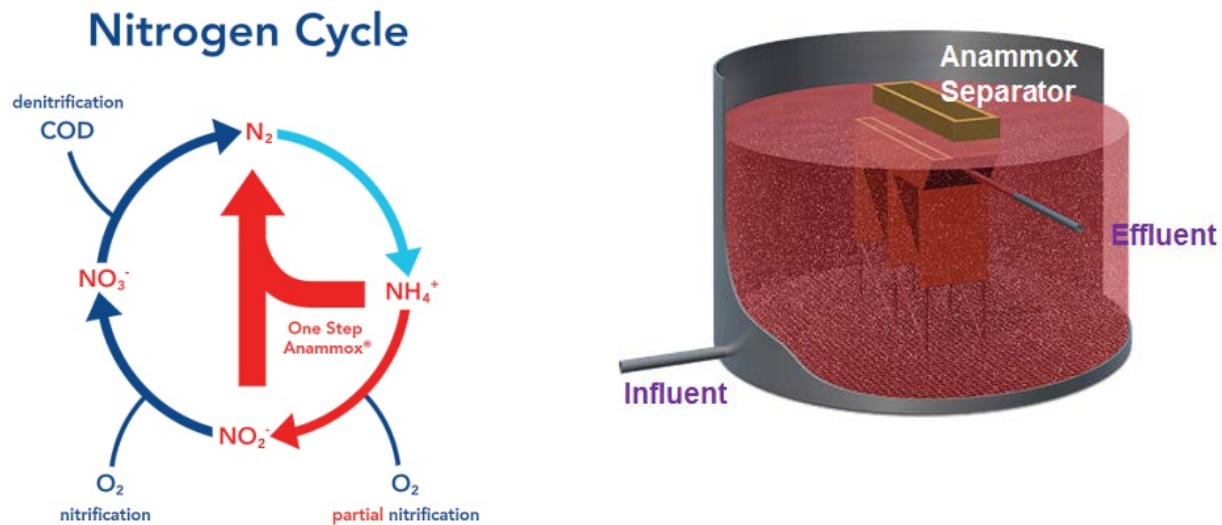

The AnammoPAQ<sup>®</sup> reactor is a continuously fed and aerated tank, equipped with Ovivo's patented biomass retention system. The aeration provides for rapid mixing of the influent with the reactor content, intense contact with the biomass and oxygen supply to drive the conversion. This process is based on granular biomass. The aeration is controlled in order to selectively convert ammonium to nitrogen gas. Around 10% of the ammonium is converted into nitrate. The treated wastewater leaves the reactor via the biomass retention system at the top of the reactor.

The granular biomass is separated from the cleaned wastewater, assuring high biomass content in the reactor. Together with the dense conversion properties typical for granular biomass, the high biomass content provides for high loading/conversion rates and therefore a small reactor volume.

© Copyright 2019 OVIVO. All rights reserved.

This document is confidential and shall remain the sole property of Ovivo. This document may not be reproduced or distributed without prior written approval of Ovivo. The data and information provided is furnished on a restricted basis and is not to be used in any way detrimental to the interests of Ovivo.

THIS BUDGETARY PROPOSAL CONSTITUTES A NON-BINDING ESTIMATE OF PRICE(S) FOR CERTAIN GOODS AND/OR SERVICES THAT MAY BE PROVIDED BY OVIVO USA LLC FROM TIME TO TIME, BUT SHALL NOT BE CONSTRUED AS A CONTRACTUAL OFFER FOR OVIVO USA LLC TO PROVIDE SUCH GOODS AND/OR SERVICES. ANY CONTRACTUAL OFFER FOR THE SUPPLY OF GOODS AND/OR SERVICES BY OVIVO USA LLC SHALL BE CONVEYED TO CUSTOMER IN THE FORM OF OVIVO USA LLC'S STANDARD PROPOSAL DOCUMENT, WHICH INCLUDES, BUT IS NOT LIMITED TO, ITS STANDARD TERMS AND CONDITIONS OF SALE. SUCH PROPOSAL FORM MAY BE PROVIDED TO CUSTOMER UPON REQUEST.

## AnammoPAQ® PROCESS ADVANTAGES

Main benefits of implementing the AnammoPAQ® system for Nitrogen removal are the significant savings on operational costs and environmental impact compared to conventional and alternative deammonification systems. These include:

- Aeration Energy Savings (over 60%)
- Elimination of external Carbon source (100% saving)
- Reduction in sludge production (up to 90%)
- Compact footprint
- High Loading Rates
- Reduction in CO2 emission
- Limited chemical consumption
- Fast start up due to inoculation with granular biomass
- Robust process: Tolerant to presence of toxic chemicals
- Ability to handle high suspended solids in influent

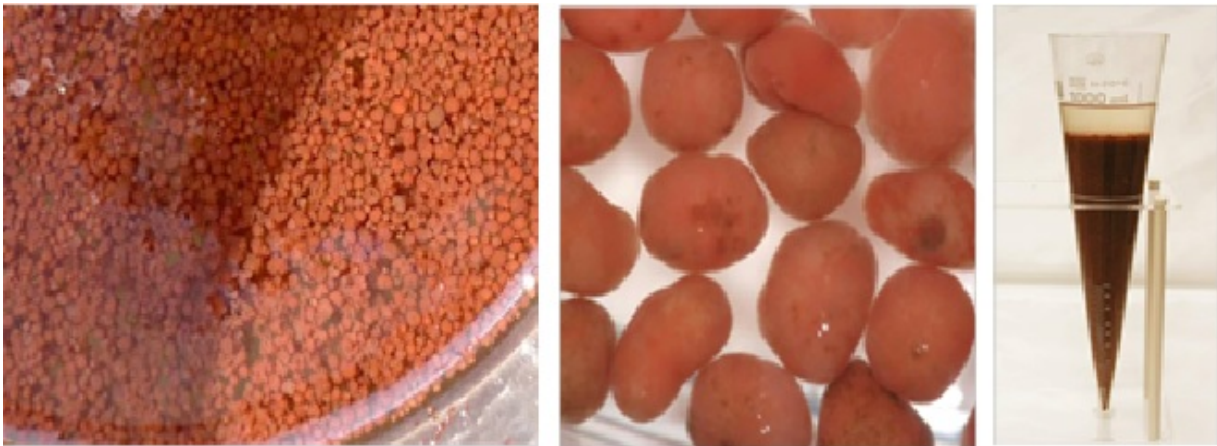

**Anammox Granular Biomass**

## AnammoPAQ® PROCESS DESIGN

The system for the King County South WWTP, WA has been designed using proprietary models to perform process selection and to determine essential operating parameters.

A summary of the AnammoPAQ® system design is provided in Table 2. This table demonstrates the volumes required to achieve desired effluent Ammonia-N reduction, and provides associated process design details.

Treatment Parameter	Unit	Peak Month	Peak Day
Equalized Design Flow	MGD	0.66	1.0
Total No. of AnammoPAQ® Reactors	#	1	2
Volume of AnammoPAQ® Reactor (each)	Gallons	515,000	515,000
Length of AnammoPAQ® Reactor (each)	ft	58.7	58.7
Width of AnammoPAQ® Reactor (each)	ft	58.7	58.7
SWD of AnammoPAQ® Reactor	ft	20	20
Foot print	ft <sup>2</sup>	3,445	6,890
Air Flow for AnammoPAQ® Reactor (each)	scfm	3,700	3,700

© Copyright 2019 OVIVO. All rights reserved.

This document is confidential and shall remain the sole property of Ovivo. This document may not be reproduced or distributed without prior written approval of Ovivo. The data and information provided is furnished on a restricted basis and is not to be used in any way detrimental to the interests of Ovivo.

THIS BUDGETARY PROPOSAL CONSTITUTES A NON-BINDING ESTIMATE OF PRICE(S) FOR CERTAIN GOODS AND/OR SERVICES THAT MAY BE PROVIDED BY OVIVO USA LLC FROM TIME TO TIME, BUT SHALL NOT BE CONSTRUED AS A CONTRACTUAL OFFER FOR OVIVO USA LLC TO PROVIDE SUCH GOODS AND/OR SERVICES. ANY CONTRACTUAL OFFER FOR THE SUPPLY OF GOODS AND/OR SERVICES BY OVIVO USA LLC SHALL BE CONVEYED TO CUSTOMER IN THE FORM OF OVIVO USA LLC'S STANDARD PROPOSAL DOCUMENT, WHICH INCLUDES, BUT IS NOT LIMITED TO, ITS STANDARD TERMS AND CONDITIONS OF SALE. SUCH PROPOSAL FORM MAY BE PROVIDED TO CUSTOMER UPON REQUEST.

## SCOPE

### SCOPE OF SUPPLY

The following table outlines the Ovivo AnammoPAQ® system scope of supply for the proposed project.

Scope of Supply		
Item	Qty	Description
1	2	AnammoPAQ® reactor <u>internals</u> (suitable for each 515,000-Gal tank – tank by others) <ul style="list-style-type: none"> <li>• 2 x Type 25 Settler and support construction</li> <li>• Fine Bubble aeration system with AeroStrip® diffusers, basin piping for c/w drop legs, flanged diffuser pipes, mounting brackets and connection fasteners</li> <li>• Piping for aeration, influent, effluent, biomass sampling</li> </ul>
2	5 (4+1)	Process Air Blowers for AnammoPAQ® with VFD; Capacity: 1,850 scfm each
3	Lot	Anammox granular biomass
4	Lot	Controls and Instrumentation (NH <sub>4</sub> <sup>+</sup> , NO <sub>3</sub> <sup>-</sup> , NO <sub>2</sub> <sup>-</sup> , DO, pH, T)
5	2	Sets of O&M Manuals
6	2	Sets of Detailed Shop Drawings
7	20	Service Days, to inspect equipment installation, test all supplied components, assist in start-up and train plant personnel.

© Copyright 2019 OVIVO. All rights reserved.

This document is confidential and shall remain the sole property of Ovivo. This document may not be reproduced or distributed without prior written approval of Ovivo. The data and information provided is furnished on a restricted basis and is not to be used in any way detrimental to the interests of Ovivo

THIS BUDGETARY PROPOSAL CONSTITUTES A NON-BINDING ESTIMATE OF PRICE(S) FOR CERTAIN GOODS AND/OR SERVICES THAT MAY BE PROVIDED BY OVIVO USA LLC FROM TIME TO TIME, BUT SHALL NOT BE CONSTRUED AS A CONTRACTUAL OFFER FOR OVIVO USA LLC TO PROVIDE SUCH GOODS AND/OR SERVICES. ANY CONTRACTUAL OFFER FOR THE SUPPLY OF GOODS AND/OR SERVICES BY OVIVO USA LLC SHALL BE CONVEYED TO CUSTOMER IN THE FORM OF OVIVO USA LLC'S STANDARD PROPOSAL DOCUMENT, WHICH INCLUDES, BUT IS NOT LIMITED TO, ITS STANDARD TERMS AND CONDITIONS OF SALE. SUCH PROPOSAL FORM MAY BE PROVIDED TO CUSTOMER UPON REQUEST.



## ITEMS BY OTHERS

The following items are specifically not by Ovivo. They may or may not be required.

Items Not Included	
Air Main Piping and all accessories including valves, bolts gaskets and connectors for attaching to drop pipes	Yard Hydrants
Chemical Feed Systems for alkalinity correction, magnesium oxide, nutrients, methanol and defoamer	Mixers
Chemicals for operation: Including methanol, nutrients, alkaline solution, defoamer	Motor Control Center (MCC)
Cleanouts	Non-potable water supply
Concrete	Overflow structures including baffles and weir plates
Drains	Power
Dryers	Dilution Water
Engines/Generators	Pre-treatment systems for deammonification system (e.g. influent TSS removal system, Phosphorus removal system and COD removal system)
Equalization Tank and equipment therein	Sludge handling and disposal
Foam control	Support Platforms
Hoses /Bibs	Tanks (and modifications to tankage – existing or new)
Influent/Feed Pumps	Transformers
Interconnecting Piping	Valves – Manual and Automatic
Laboratory	Variable Frequency Drives for blowers and pumps
Ladders (caged or other types) and Handrails	Ventilation
Lighting	Walkways/Roofing/Stairs/Gratings/Handrails
Liquid sampling and analytical work	Wireways/Wiring
Local control panels for blowers etc.	Yard Piping

© Copyright 2019 OVIVO. All rights reserved.

This document is confidential and shall remain the sole property of Ovivo. This document may not be reproduced or distributed without prior written approval of Ovivo. The data and information provided is furnished on a restricted basis and is not to be used in any way detrimental to the interests of Ovivo

THIS BUDGETARY PROPOSAL CONSTITUTES A NON-BINDING ESTIMATE OF PRICE(S) FOR CERTAIN GOODS AND/OR SERVICES THAT MAY BE PROVIDED BY OVIVO USA LLC FROM TIME TO TIME, BUT SHALL NOT BE CONSTRUED AS A CONTRACTUAL OFFER FOR OVIVO USA LLC TO PROVIDE SUCH GOODS AND/OR SERVICES. ANY CONTRACTUAL OFFER FOR THE SUPPLY OF GOODS AND/OR SERVICES BY OVIVO USA LLC SHALL BE CONVEYED TO CUSTOMER IN THE FORM OF OVIVO USA LLC'S STANDARD PROPOSAL DOCUMENT, WHICH INCLUDES, BUT IS NOT LIMITED TO, ITS STANDARD TERMS AND CONDITIONS OF SALE. SUCH PROPOSAL FORM MAY BE PROVIDED TO CUSTOMER UPON REQUEST.

## ADDITIONAL ITEMS BY INSTALLING CONTRACTOR

- 1 Obtain necessary construction permits and licenses, construction drawings (including interconnecting piping drawings) field office space, telephone service, and temporary electrical service.
- 2 All site preparation, grading, locating foundation placement, excavation for foundation, underground piping, conduits and drains.
- 3 Demolition and/or removal of any existing structures, equipment or facilities required for construction and installation of the AnammoPAQ® system.
- 4 Installation of all foundation - supply and installation of all embedded or underground piping, conduits and drains.
- 5 All backfill, compaction, finish grading, earthwork and final paving.
- 6 Receiving (preparation of receiving reports), unloading, storage, maintenance preservation and protection of all equipment and materials supplied by Ovivo.
- 7 Installation of all equipment and materials supplied by Ovivo.
- 8 Supply, fabrication, installation, cleaning, pickling and/or passivation of all interconnecting steel piping components.
- 9 Provide and install all embedded pipe sections and valves for tank drains and reactor inlets and elbows.
- 10 All cutting, welding, fitting and finishing for all field fabricated piping.
- 11 Supply and installation of all flange gaskets and bolts for all piping components.
- 12 Supply and installation of all pipe supports and wall penetrations.
- 13 Install and provide all motor control centers, motor starters, panels, field wiring, wireways, supports and transformers.
- 14 Install all control panels and instrumentation as supplied by Ovivo, as applicable.
- 15 Supply and install all electrical power and control wiring and conduit to the equipment served plus interconnection between the Ovivo equipment as required, including wire, cable, junction boxes, fittings, conduit, cable trays, safety disconnect switches, circuit breakers, etc.
- 16 Supply and install all insulation, supports, drains, gauges, hold down clamps, condensate drain systems, flanges, flex pipe joints, expansion joints, boots, gaskets, adhesives, fasteners, safety signs, and any specialty items such as traps.
- 17 All labor, materials, supplies and utilities as required for start-up including laboratory facilities and analytical work.
- 18 Provide all chemicals required for plant operation and all chemicals, lubricants, glycol, oils or grease and other supplies thereafter.

- 19 Install all anchor bolts and mounting hardware supplied by Ovivo; and supply and install all anchor bolts and mounting hardware not specifically supplied by Ovivo.
- 20 Provide all nameplates, safety signs and labels.
- 21 Provide all additional support beams and/or slabs.
- 22 Provide and install all manual valves.
- 23 Provide and install all piping required to interconnect to the Ovivo's equipment.
- 24 The Contractor shall coordinate the installation and timing of interface points such as piping and electrical with the Ovivo Supplier.

***All other necessary equipment and services not otherwise listed as specifically supplied by Ovivo.***

**BUDGET PRICE**

Our current budget estimate price for the AnammoPAQ® system, as described in this proposal is:

Description	Price
AnammoPAQ® system as described above	<b>As Advised by Rep</b> <b>\$7,565,000</b>

**NOTES –**

1. Our Price and Payment Terms are based on Ovivo's standard terms and conditions, which can be provided upon request.
2. This price will be valid for thirty (30) days.
3. All prices are excluding Washington state sales and use taxes and any federal taxes which shall be the sole responsibility of the Client. No additional duties will have to be paid for the equipment supplied by Ovivo.
4. Pricing is subject to the London Metal exchange index for stainless steel rolled coil calculated from the original proposal date and is in accordance with the Scope of Supply and terms of this proposal and any changes may require the price to be adjusted.

**Shipping Terms**

FOB Shipping Point, Full Freight Allowed

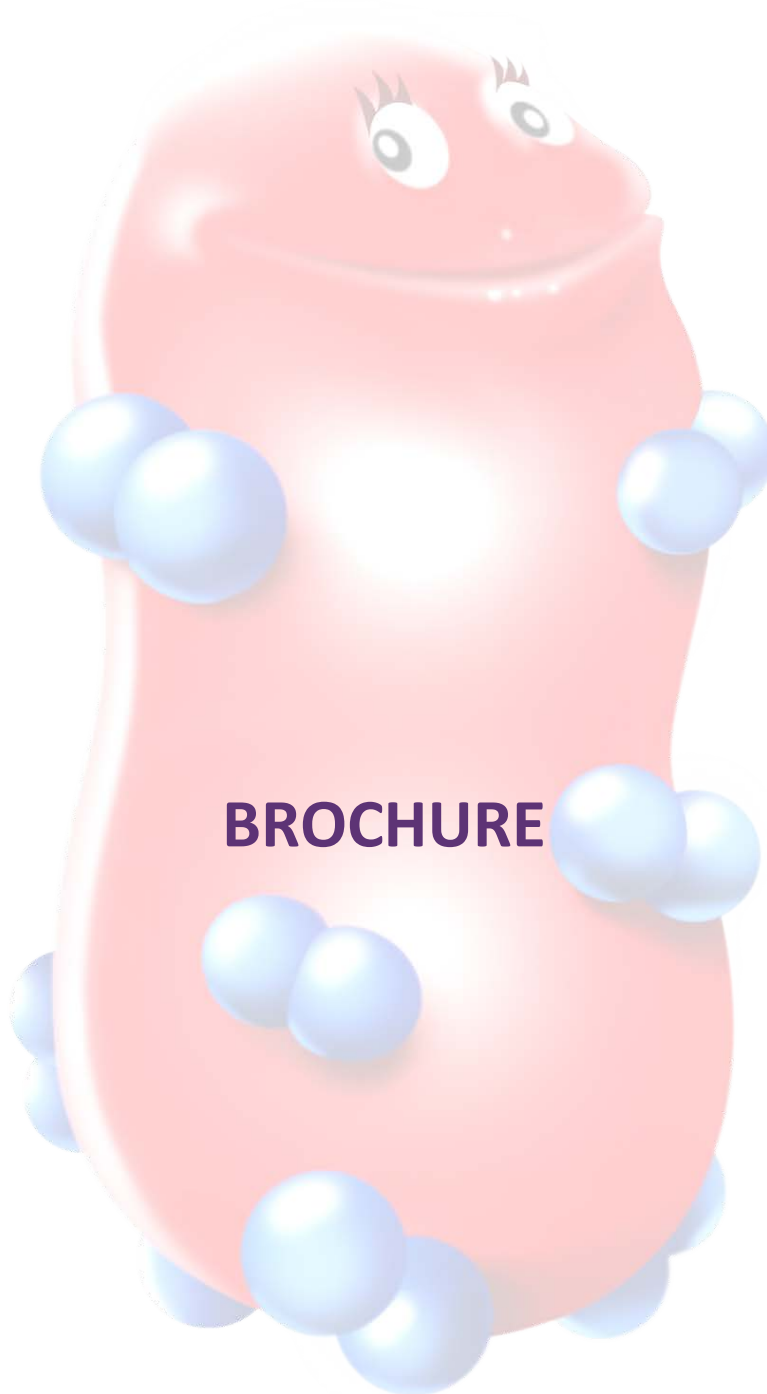

# BROCHURE

---

**© Copyright 2019 OVIVO. All rights reserved.**

This document is confidential and shall remain the sole property of Ovivo. This document may not be reproduced or distributed without prior written approval of Ovivo. The data and information provided is furnished on a restricted basis and is not to be used in any way detrimental to the interests of Ovivo

THIS BUDGETARY PROPOSAL CONSTITUTES A NON-BINDING ESTIMATE OF PRICE(S) FOR CERTAIN GOODS AND/OR SERVICES THAT MAY BE PROVIDED BY OVIVO USA LLC FROM TIME TO TIME, BUT SHALL NOT BE CONSTRUED AS A CONTRACTUAL OFFER FOR OVIVO USA LLC TO PROVIDE SUCH GOODS AND/OR SERVICES. ANY CONTRACTUAL OFFER FOR THE SUPPLY OF GOODS AND/OR SERVICES BY OVIVO USA LLC SHALL BE CONVEYED TO CUSTOMER IN THE FORM OF OVIVO USA LLC'S STANDARD PROPOSAL DOCUMENT, WHICH INCLUDES, BUT IS NOT LIMITED TO, ITS STANDARD TERMS AND CONDITIONS OF SALE. SUCH PROPOSAL FORM MAY BE PROVIDED TO CUSTOMER UPON REQUEST.

## OVIVO-PAQUES AnammoPAQ™ PROCESS

### SUSTAINABLE NITROGEN REMOVAL

#### HOW WE CREATE VALUE

Cost-effective nitrogen removal from digester sidestreams (with or without THP) using Anammox

Compared to conventional nitrification and denitrification:

- 60% energy savings compared
- 100% reduction in supplemental organic carbon
- 90% reduction in sludge production
- 90% reduction in footprint
- 85% reduction in CO<sub>2</sub> emissions

Quick startup time with potential for full process optimization within 3 weeks

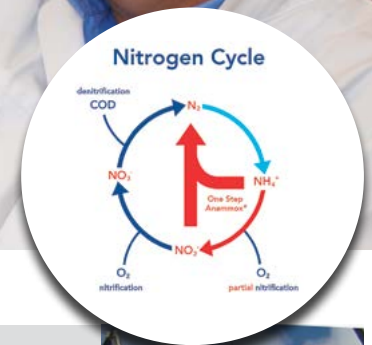

#### THE CHALLENGE

- Despite representing 1% to 3% of the flow to the mainstream, typical anaerobic digester sidestream contains 10% to 30% of the nitrogen load, with concentrations often in excess of 1,000 mg/L ammonia-N
- Sludge pre-treatment with THP can double the ammonia-N concentrations in the sidestream
- Stringent BNR limits on main stream
- Conventional nitrification and denitrification requires significant aeration energy and supplemental carbon

#### THE OVIVO SOLUTION

The AnammoPAQ™ process is an elegant shortcut in the natural nitrogen cycle. The process utilizes Anammox bacteria which directly convert ammonium (NH<sub>4</sub><sup>+</sup>) and nitrite (NO<sub>2</sub><sup>-</sup>) into nitrogen gas. Paques developed the original process for commercial purposes in cooperation with Delft University of Technology and the University of Nijmegen. Since the first full-scale plant started up in 2002 (treatment of sidestream from sludge digestion), many other plants have been installed and are running successfully.

#### The AnammoPAQ™ ADVANTAGE

- Proven technology with 15+ years operational experience
- 35+ AnammoPAQ™ references worldwide
- Largest single unit can handle 10 metric tons of nitrogen/day (equivalent to sidestream from a 250 MGD municipal plant)!
- Robust system, handling high loading variations
- Up to 60% saving on operational costs
- Savings on excess sludge production
- No addition of organic carbon source (methanol) required
- Production of valuable Anammox biomass
- High loading rates leading to compact footprint
- Lowest O&M amongst competing systems





## OPERATING PRINCIPLE

AnammoPAQ™ is a continuous flow reactor system in which nitrification and anammox conversion occur simultaneously in a single process unit. Anammox (anaerobic ammonium oxidation) conversion is an elegant short-cut in the natural nitrogen cycle where ammonium and nitrite are converted to nitrogen gas. As the Anammox process involves removal of ammonium over nitrite (NO<sub>2</sub><sup>-</sup>) rather than nitrate (NO<sub>3</sub><sup>-</sup>), 63% less oxygen (O<sub>2</sub>) is required while eliminating the need for an external carbon source altogether. Optimal process control ensures retention of AOBs and Anammox bacteria while eliminating NOBs, leading to stable & robust operation.

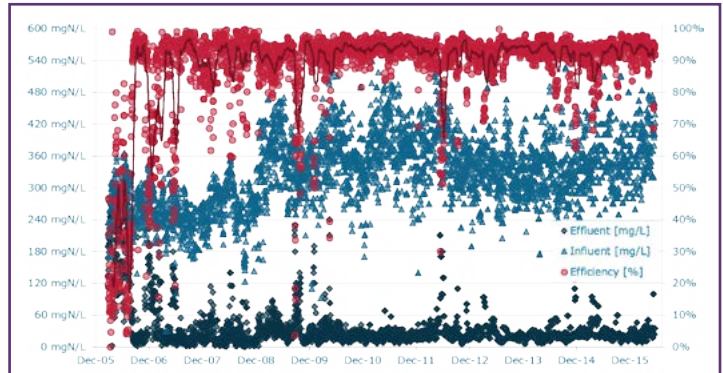
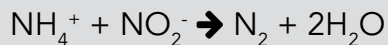

The Olburgen WWTP in Netherlands, with the Ovivo AnammoPAQ® process has reached stable & continuous 92% ammonium and 85% total nitrogen removal average for over 10 years

## HOW IT WORKS

- 1 Ammonia-rich influent
- 2 Aerators for mixing and ammonia removal process
- 3 AnammoPAQ™ separator for biomass retention
- 4 Effluent exits the reactor

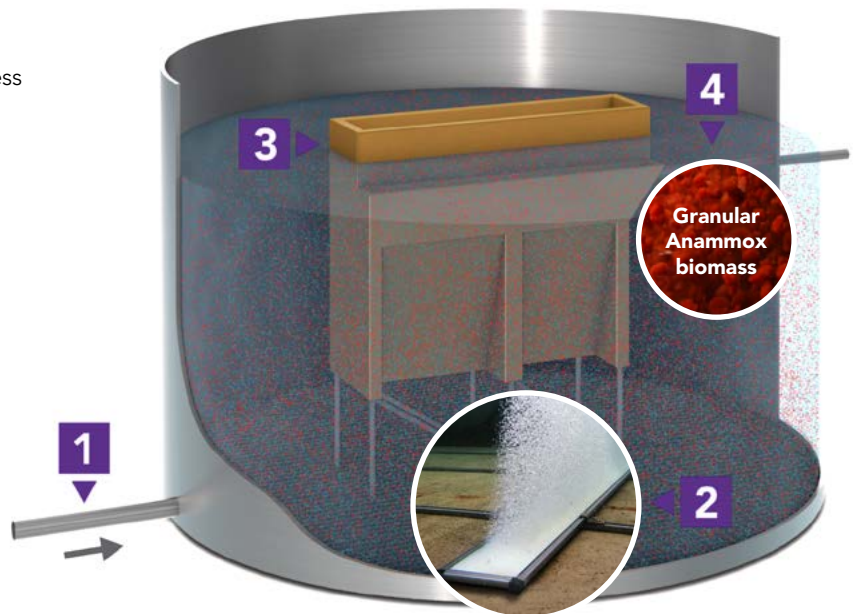

## CONTACT

1-855-GO-OVIVO ☎  
info@ovivowater.com ✉  
www.ovivowater.com 🌐





# Proposal South Treatment Plant, WA

ANITA™ Mox

Proj. No. 5700147910

Submitted to: Gus Friedman  
Brown and Caldwell

Submitted by: Robby Bailey  
Application Engineer

Date: 9/13/2019

*This document is confidential and may contain proprietary information.  
It is not to be disclosed to a third party without the written consent of Veolia Water Technologies.*

**Veolia Water Technologies Inc. (dba Kruger)**  
4001 Weston Parkway  
Cary, NC 27513  
tel. +1 919-677-8310 • fax +1 919-677-0082  
[www.krugersusa.com](http://www.krugersusa.com)

**Water Technologies**

## Introduction

Kruger (a subsidiary of Veolia Water Technologies) is pleased to present this budgetary proposal for our ANITA™ Mox process for deammonification of the anaerobic digester rejection water at the King County South Plant facility. This design is based upon the information we have received from you. The influent design criteria are summarized in Table 1.

In order to achieve the expected removals as summarized in Table 2, we recommend constructing two (2) ANITA Mox process trains. The tank dimensions along with other important process parameters are summarized in Table 3.

It is important that each reactor have the capability for independent control of influent feed and aeration. This can be accomplished through dedicated pumps and blowers or by using high performance modulating valves. We have included one (1) modulating airflow control valve per train as part of Kruger's scope to meet this need. Depending on the facilities dewatering schedule some equalization volume may provide benefits to the operations of the process.

We appreciate the opportunity to provide this proposal to you. If you have any questions or need further information, please contact our local Representative, Bill Reilly of WM Reilly, or our Regional Sales Manager, Brad Mrdjenovich, at (919)-653-4531 ([brad.mrdjenovich@veolia.com](mailto:brad.mrdjenovich@veolia.com)).

cc: LL, BM, GAT, JLY, project file (Kruger)  
WM Reilly

Revision	Date	Process Eng.	Comments
0	8/29/2019	JLY, GAT	Initial, budgetary proposal.



---

## We Know Water

Kruger is a water and wastewater solutions provider specializing in advanced and differentiating technologies. Kruger provides complete processes and systems ranging from biological nutrient removal to mobile surface water treatment. The ACTIFLO® Microsand Ballasted Clarifier, BioCon® Dryer, BIOSTYR® Biological Aerated Filter (BAF) and NEOSEP™ MBR are just a few of the innovative technologies offered. Kruger is a subsidiary of Veolia Water, a world leader in engineering and technological solutions in water treatment for industrial companies and municipal authorities.

**Veolia Water Technologies**, the fully-owned subsidiary of **Veolia**, is the world leader in water and wastewater treatment with over 155 years of experience. As an experienced design-build company and a specialized provider of technological solutions in water treatment, Veolia combines proven expertise with unsurpassed innovation to offer technological excellence to our industrial customers. Based on this expertise, we believe that we have developed the best solution for your application. Below is a brief description of the proposed project.

## Energy Focus

Kruger, along with Veolia Water Technologies is dedicated to delivering sustainable and innovative technologies and solutions.

We offer our customers integrated solutions which include resource-efficient technology to improve operations, reduce costs, achieve sustainability goals, decrease dependency on limited resources, and comply with current and anticipated regulations.

Veolia's investments in R&D outpace that of our competition. Our focus is on delivering

- neutral or positive energy solutions
- migration towards green chemicals or zero chemical consumption
- water-footprint-efficient technologies with high recovery rates

Our carbon footprint reduction program drives innovation, accelerates adoption and development of clean technologies, and offers our customers sustainable solutions.

Kruger is benchmarking its technologies and solutions by working with our customers and performing total carbon cost analysis over the lifetime of the installation.

By committing to the innovative development of clean and sustainable technologies and solutions worldwide, Kruger will continue to maximize the financial benefits for every customer.



## We Know Smart Water Management

Veolia is the only company in the world that can combine decades of water treatment expertise, process knowledge and our wide range of domestic and global references into a comprehensive digital solutions platform that provides numerous opportunities to enhance the management of water.



When AQUAVISTA™ is paired with process and equipment instrumentation, your facility will have access to the most advanced suite of cloud-based monitoring, control and technical support mechanisms in the industry. AQUAVISTA™ provides the opportunity to improve your plant's overall performance with enhancements in operational efficiencies and critical asset management. AQUAVISTA™ runs on today's most secure cloud based services and is fully accessible with any common smart devices (phone, pad, tablet).

Four (4) tiers of service are available:

- Portal: A remote monitoring and reporting tool with overview of all plant data and access to important facility documentation.
- Insight: Portal + Data driven performance optimization advice regarding the general status and operational conditions of your plant.
- Assist: Added level of access to Veolia's process experts for process, maintenance, and training support.
- Plant: Operator adjustable levels of automatic control of your treatment facility.

All levels of service provide a simple link to Veolia's customer service group to facilitate easy access to spare parts and other service needs.



## Process Description

### AnoxKaldnes MBBR

The MBBR process is a continuous-flow, non-clogging biofilm reactor containing moving “carrier elements” or media. The media flows with the water currents in the reactor and does not require backwashing or cleaning.

The biomass that treats the wastewater is attached to the surfaces of the media. The media is designed to provide a large protected surface area for the biofilm and optimal conditions for biological activity when suspended in water. AnoxKaldnes media is made from polyethylene and has a density slightly less than water.

The ANITA™ Mox process is a single-stage nitrogen removal process based on the MBBR platform. The process is specifically designed for treatment of waste streams with high ammonia concentrations. The system can achieve ammonia removals of up to 80-90% and total nitrogen removals of up to 75-85%. The treatment method uses only 40% of the oxygen demand of conventional nitrification, and it requires no external carbon source.

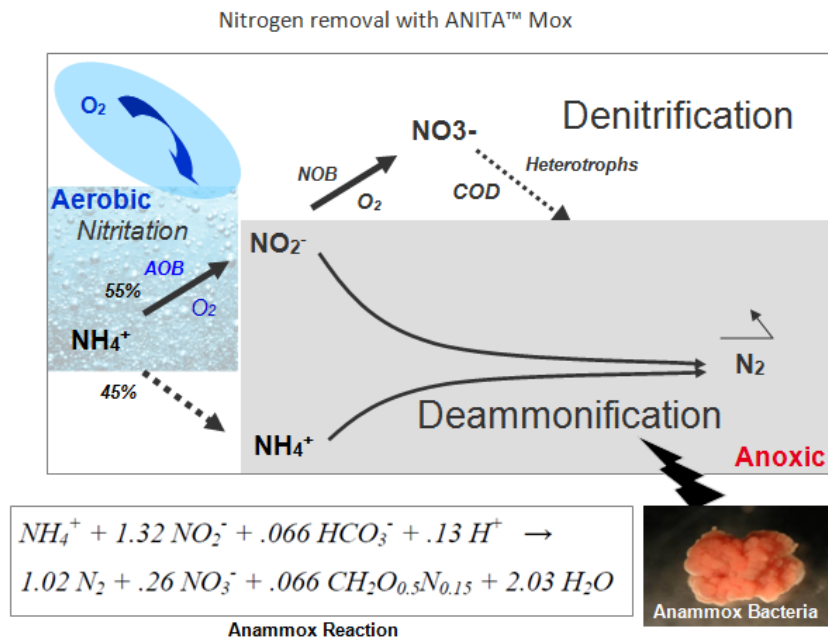

The ANITA Mox process consists of an aerobic nitritation reaction and an anoxic ammonia oxidation (anammox) reaction. The two steps take place simultaneously in different layers of the biofilm. Nitritation occurs in the outer layer of the biofilm. Approximately 55% of the influent ammonia is oxidized to nitrite (NO<sub>2</sub><sup>-</sup>). Anammox activity occurs in the inner layer. In this step, the nitrite produced and the remaining ammonia are utilized by the anammox bacteria and converted to nitrogen gas (N<sub>2</sub>) and a small amount of nitrate (NO<sub>3</sub><sup>-</sup>).



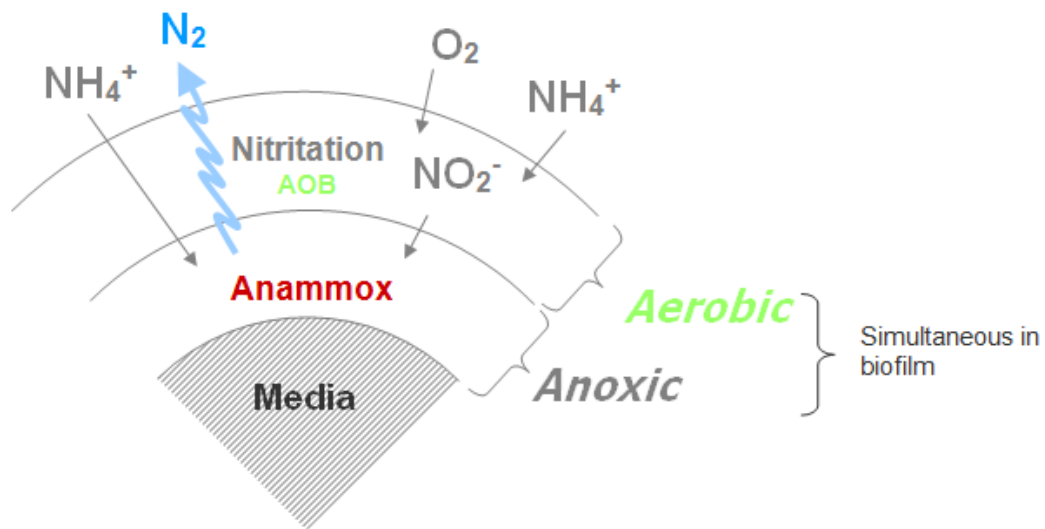

The aerobic and anoxic reactions occur in a single MBBR reactor. The combined biomass grows attached to the AnoxKaldnes media and is retained in the reactor by media screens. This biomass retention is an important characteristic of the system, since the anammox bacteria growth rate is very slow when compared to conventional wastewater bacteria growth rates.





## AnoxKaldnes ANITA™ Mox System Configuration

Kruger proposes the ANITA™ Mox process for deammonification at the King County South Plant facility. We recommend constructing two (2) ANITA Mox MBBR process trains using our AnoxK™5 media.

Kruger's equipment scope of supply includes:

- ✓ AnoxKaldnes media
- ✓ Screen assemblies (to keep media in each reactor)
- ✓ Medium bubble aeration grids
- ✓ Mixers
- ✓ Process control system
- ✓ Field instruments

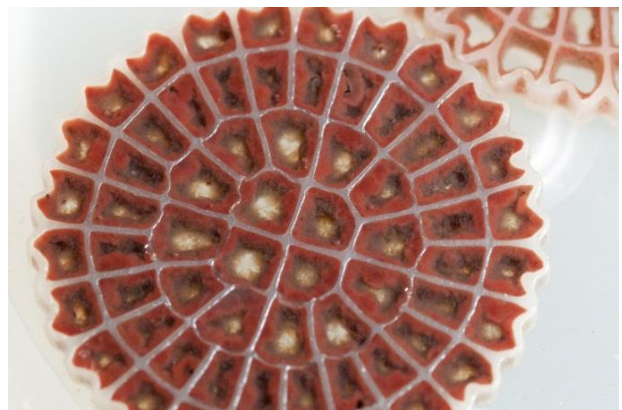



## Design Summary

This design assumes that the side stream entering into the proposed ANITA Mox system contains no toxic compounds and that none of the equipment provided would be used in a classified area (e.g. Class 1, Division 1 or Class 1, Division 2).

The ANITA Mox influent design basis is summarized in Table 1. The target effluent criteria for the ANITA Mox system are listed in Table 2. The process design is summarized in Table 3.

Our design approach is to compare two possible treatment scenarios to determine the necessary media volumes and airflow requirements for a two train, newly-constructed reactor with a 21' side water depth. Reactor and air grid sizes are designed at the maximum fill fraction for peak day conditions. Given these constraints, we have estimated the ammonia removal capacity of the reactor using our proprietary design tools.

**Table 1: Influent Design Basis**

Parameter	Units	Max month	Peak day
Flow, Design	MGD	0.66	1.0
BOD <sub>5</sub> *, Design Flow	mg/L	72	72
COD*, Design Flow	mg/L	400	400
TSS*, Design Flow	mg/L	350	350
TKN, Design Flow	mg/L	1456	1456
NH <sub>4</sub> -N, Design Flow	mg/L	1354	1354
Alkalinity, Design Flow	mg/L	4,239	4,239
Elevation*	ft	100	100
Temperature	°C	30.0	30.0

\*Assumed values

**Table 2: Target Effluent Concentrations**

Parameter	Units	Value
NH <sub>4</sub> -N	mg/L	< 270
Total Inorganic Nitrogen	mg/L	< 410



**Table 3: Process Design Summary**

Parameter	Units	Max month
Number of Process Trains	-	2
Reactor Dimensions (Each)*	ft	83 L × 41 W × 21 SWD
Reactor Volume (Each)	ft <sup>3</sup>	71,463
Reactor Volume (Total)	ft <sup>3</sup>	142,926
Recommended Freeboard for reactors	ft	2 – 3
Media Type:	-	AnoxK™5
Fill of Biofilm Carriers, All Reactors	%	37
Media Volume (Each reactor)	ft <sup>3</sup>	26,094
Media Volume (Total)	ft <sup>3</sup>	52,188
Aeration System Type	-	Medium Bubble
Residual DO, Design	mg/L	1.5
Estimated Process Air Requirement, Design** (Max Month / Peak Day)	SCFM	~4,004 / ~6,067
Pressure (From Top of Drop Pipe)	psi	9.0

\*Reactor geometries can be modified as necessary to accommodate site conditions.

\*\*Note: Process airflow values that are presented do not include peaking/safety factor.



---

## **Scope of Supply**

Kruger is pleased to present our scope of supply which includes process engineering design, equipment procurement, and field services required for the proposed treatment system, as related to the equipment specified. The work will be performed to Kruger's high standards under the direction of a Project Manager. All matters related to the design, installation, or performance of the system shall be communicated through the Kruger representative giving the Engineer and Owner ready access to Kruger's extensive capabilities.

### **Process and Design Engineering**

Kruger will provide process engineering and design support for the system as follows:

- Process Engineering consisting of aeration system sizing and configuration, sieve and outlet design.
- Review and approval of P&I Diagram for the AnoxKaldnes ANITA Mox portion of the process. Preliminary General Arrangement Drawings and review and approval of final General Arrangement Drawings for the process. Review of reactor drawings with respect to penetrations and dimensions, excluding structural design.
- Equipment installation instructions for all equipment supplied by Kruger.

### **Field Services**

Kruger will furnish a Service Engineer to perform the following tasks:

- Inspect installation of key pieces of equipment during construction.
- Inspect the completed system prior to startup.
- Assist the Contractor with initial startup of the system.
- Train the Owner's staff in the proper operation and maintenance of the AnoxKaldnes ANITA Mox system.
- Test and start any Kruger-supplied control equipment, including PLC programming and SCADA systems.



### AnoxKaldnes ANITA™ Mox System Equipment\*

Mechanical Equipment Items	Qty	Description
AnoxKaldnes AnoxK™5 Media, (ft <sup>3</sup> ) – Maximum Month Condition	52,188	Carrier elements are made of high density polyethylene. The total media quantity will include a volume of ~5% seeded media.
Cylindrical Screen Assemblies	4	Two (2) per reactor. 304L SS. 23"ø perforated plate pipes terminated in ANSI flanges for mounting directly to the tank wall.
Medium Bubble Aeration System	16	Eight (8) air grids per reactor. 304L SS including header, lateral piping, and hardware (excluding concrete anchor bolts). One (1) manual BFV for each air grid drop pipe is also provided.
Specially Designed Mechanical Mixers	4	Two (2) per ANITA Mox Reactor. Includes VFD.
Airlift Pump	6	Three (3) airlift pumps per ANITA Mox reactor for foam suppression.
Modulating Airflow Control Valves	2	One (1) actuated High-Performance Butterfly Valve for each aerobic reactor.

\*Note: Equipment sized for peak day (media fill of 55%). Scope includes enough media for max month condition.

Instrumentation and Controls Equipment Items	Qty	Description
PLC Control Panel	1	NEMA 12 Freestanding or Wall Mount Control Panel (For Indoor Use). ControlLogix PLC; Panelview HMI; 120V Feed
pH-based Control Logic	1	For optional mode of aeration control.
High Level Float Switch	2	One (1) for each media zone.
DO Probe (LDO)	2	One (1) for each Aerobic zone. Aerobic Zone DO Monitoring
pH meter	2	One (1) pH meter for each ANITA Mox reactor.
Influent Ammonia Nitrogen Probe	1	One (1) ammonia nitrogen probe for all process trains
Combination Ammonia / Nitrate Nitrogen Probes	2	One (1) combination ammonia / nitrate nitrogen probe for each ANITA Mox reactor.
Thermal Mass Flowmeter	2	One (1) for each ANITA Mox reactor for air flow control
Magnetic Flowmeter	2	One (1) magnetic flow meter per reactor to measure influent flow.
Instrumentation and Controls (NOT INCLUDED)	Qty	Description
Centrate Feed Pump	2+1	One (1) duty plus one (1) standby to feed centrate from equalization tank. Includes VFD.



## Notes Regarding System Design and Installation

- A note on concrete specifications: For any MBBR or IFAS system, regardless of manufacturer, it is sound practice to require good, quality concrete work for the process reactors. The Consulting Engineer's standard concrete specification section is typically adequate to eliminate large holes, excessive form marks, large pockets, and excessively rough areas. It is particularly important to eliminate the potential for annular space around media retention screens.
- A note on construction sequencing: It is important, particularly for IFAS installations, to have level detection and level communication systems in place and operational prior to the filling of process tanks with water and media.

## Scope of Supply BY INSTALLER/PURCHASER

The scope of supply by others for the AnoxKaldnes ANITA™ Mox system should include, but is not limited to, the following items:

- All civil/site and electrical work.
- A concrete foundation for the tanks.
- Reactors to house the MBBR treatment equipment.
- All provisions for interconnecting piping.
- Unloading, storage and installation of equipment.
- Install and test all level floats, level transmitters, level alarms, and alarm communication devices prior to filling a process tank with media and water
- Centrate equalization tanks
- Cover for reactor tanks (if necessary)
- Temporary provisions for screened primary or secondary effluent during startup.
- Temporary reactor heating during startup.
- Mixer bridges and other structural modifications for the reactors.
- Video recording of any training activities.

## **Design Options**

In addition to the proposed system as detailed herein, Kruger is able to further incorporate our process and controls expertise into wastewater treatment plants, allowing municipalities to meet stringent effluent requirements and future plant upgrades. Kruger is also able to offer our instrumentation and controls expertise to build upon the proposed system by providing a **customized plant-wide SCADA system** or designing a **Motor Control Center (MCC)**, providing clients a single source responsibility for plant controls. Please contact Kruger if the options above are of interest or to be included in the current proposed system or future upgrades. *\*\*Please note that the design options listed above are not included in the pricing noted herein.*



---

## Schedule

- Shop drawings will be submitted within 6-8 weeks of receipt of an executed contract by all parties.
- All equipment will be delivered within 18-20 weeks after receipt of written approval of the shop drawings.
- Installation manuals will be furnished upon delivery of equipment.
- Operation and Maintenance Manuals will be submitted within 90 days after receipt of approved shop drawings.

## Pricing

The price for the AnoxKaldnes ANITA™ Mox system, as defined herein, including process and design engineering, field services, and equipment supply is: **\$2,855,000**

Pricing is FOB shipping point, with freight allowed to the job site. This pricing does not include any sales or use taxes. In addition, pricing is valid for ninety (90) days from the date of issue.

***Please note that the above pricing is expressly contingent upon the items in this proposal and are subject to Kruger's Standard Terms of Sale detailed herein.***

## Kruger Standard Terms of Payment

The terms of payment are as follows:

- 10% on receipt of fully executed contract
- 15% on submittal of shop drawings
- 75% on the delivery of equipment to the site

Payment shall not be contingent upon receipt of funds by the Contractor from the Owner. There shall be no retention in payments due to Kruger. All other terms per our Standard Terms of Sale are attached.

All payment terms are net 30 days from the date of invoice. Final payment not to exceed 120 days from delivery of equipment.



## Kruger Standard Terms of Sale

1. Applicable Terms. These terms govern the purchase and sale of the equipment and related services, if any (collectively, "Equipment"), referred to in Seller's purchase order, quotation, proposal or acknowledgment, as the case may be ("Seller's Documentation"). Whether these terms are included in an offer or an acceptance by Seller, such offer or acceptance is conditioned on Buyer's assent to these terms. Seller rejects all additional or different terms in any of Buyer's forms or documents.
  2. Payment. Buyer shall pay Seller the full purchase price as set forth in Seller's Documentation. Unless Seller's Documentation provides otherwise, freight, storage, insurance and all taxes, duties or other governmental charges relating to the Equipment shall be paid by Buyer. If Seller is required to pay any such charges, Buyer shall immediately reimburse Seller. All payments are due within 30 days after receipt of invoice. Buyer shall be charged the lower of 1 ½% interest per month or the maximum legal rate on all amounts not received by the due date and shall pay all of Seller's reasonable costs (including attorneys' fees) of collecting amounts due but unpaid. All orders are subject to credit approval.
  3. Delivery. Delivery of the Equipment shall be in material compliance with the schedule in Seller's Documentation. Unless Seller's Documentation provides otherwise, Delivery terms are F.O.B. Seller's facility.
  4. Ownership of Materials. All devices, designs (including drawings, plans and specifications), estimates, prices, notes, electronic data and other documents or information disclosed by Seller or prepared solely by Seller or Buyer or jointly by Seller and Buyer in connection with this Agreement, and all intellectual property rights therein, shall be and remain the confidential and proprietary property of Seller, whether or not patented by Seller ("Work Product"). Buyer hereby irrevocably assigns all rights in any Work Product to Seller. Seller grants Buyer a non-exclusive, non-transferable (except to a successor-in interest to the ownership of the Equipment), paid-up license to use the Work Product solely in connection with Buyer's use, operation, repair and maintenance of the Equipment at the Jobsite defined in this Agreement. Buyer may not disclose, share, transfer, or sell any such Work Product to third parties without Seller's prior written consent and such consent may be arbitrarily withheld. Buyer agrees not to resell, transfer or give any of the biologically colonized media or bacteria from the system to any party other than Seller or any of Seller's affiliates without the prior written consent of Seller for a period of fifteen (15) years from the effective date of this Agreement. Buyer shall not cultivate bacteria or use biomass carriers retrieved from the ANITA Mox system for any research or non-research purposes without prior written consent of the Seller. Any new developments, discoveries or inventions resulting from the operation of the ANITA Mox system in which the ANITA Mox process is a component or is in any way incorporated in whole or in part shall be owned solely by the Seller.
  5. Changes. Seller shall not implement any changes in the scope of work described in Seller's Documentation unless Buyer and Seller agree in writing to the details of the change and any resulting price, schedule or other contractual modifications. This includes any changes necessitated by a change in applicable law occurring after the effective date of any contract including these terms.
  6. Warranty. Subject to the following sentence, Seller warrants to Buyer that the Equipment shall materially conform to the description in Seller's Documentation and shall be free from defects in material and workmanship. The foregoing warranty shall not apply to any Equipment that is specified or otherwise demanded by Buyer and is not manufactured or selected by Seller, as to which (i) Seller hereby assigns to Buyer, to the extent assignable, any warranties made to Seller and (ii) Seller shall have no other liability to Buyer under warranty, tort or any other legal theory. If Buyer gives Seller prompt written notice of breach of this warranty within 18 months from delivery or 1 year from beneficial use, whichever occurs first (the "Warranty Period"), Seller shall, at its sole option and as Buyer's sole remedy, repair or replace the subject parts or refund the purchase price therefore. If Seller determines that any claimed breach is not, in fact, covered by this warranty, Buyer shall pay Seller its then customary charges for any repair or replacement made by Seller. Seller's warranty is conditioned on Buyer's (a) operating and maintaining the Equipment in accordance with Seller's instructions, (b) not making any unauthorized repairs or alterations, and (c) not being in default of any payment obligation to Seller. Seller's warranty does not cover damage caused by chemical action or abrasive material, misuse or improper installation (unless installed by Seller). THE WARRANTIES SET FORTH IN THIS SECTION ARE SELLER'S SOLE AND EXCLUSIVE WARRANTIES AND ARE SUBJECT TO SECTION 10 BELOW. SELLER MAKES NO OTHER WARRANTIES OF ANY KIND, EXPRESS OR IMPLIED, INCLUDING WITHOUT LIMITATION, ANY WARRANTY OF MERCHANTABILITY OR FITNESS FOR PURPOSE.
  7. Indemnity. Seller shall indemnify, defend and hold Buyer harmless from any claim, cause of action or liability incurred by Buyer as a result of third party claims for personal injury, death or damage to tangible property, to the extent caused by Seller's negligence. Seller shall have the sole authority to direct the defense of and settle any indemnified claim. Seller's indemnification is conditioned on Buyer (a) promptly, within the Warranty Period, notifying Seller of any claim, and (b) providing reasonable cooperation in the defense of any claim.
  8. Force Majeure. Neither Seller nor Buyer shall have any liability for any breach (except for breach of payment obligations) caused by extreme weather or other act of God, strike or other labor shortage or disturbance, fire, accident, war or civil disturbance, delay of carriers, failure of normal sources of supply, act of government or any other cause beyond such party's reasonable control.
  9. Cancellation. If Buyer cancels or suspends its order for any reason other than Seller's breach, Buyer shall promptly pay Seller for work performed prior to cancellation or suspension and any other direct costs incurred by Seller as a result of such cancellation or suspension.
  10. LIMITATION OF LIABILITY. NOTWITHSTANDING ANYTHING ELSE TO THE CONTRARY, SELLER SHALL NOT BE LIABLE FOR ANY CONSEQUENTIAL, INCIDENTAL, SPECIAL, PUNITIVE OR OTHER INDIRECT DAMAGES, AND SELLER'S TOTAL LIABILITY ARISING AT ANY TIME FROM THE SALE OR USE OF THE EQUIPMENT SHALL NOT EXCEED THE PURCHASE PRICE PAID FOR THE EQUIPMENT. THESE LIMITATIONS APPLY WHETHER THE LIABILITY IS BASED ON CONTRACT, TORT, STRICT LIABILITY OR ANY OTHER THEORY.
- Miscellaneous. If these terms are issued in connection with a government contract, they shall be deemed to include those federal acquisition regulations that are required by law to be included. These terms, together with any quotation, purchase order or acknowledgement issued or signed by the Seller, comprise the complete and exclusive statement of the agreement between the parties (the "Agreement") and supersede any terms contained in Buyer's documents, unless separately signed by Seller. No part of the Agreement may be changed or cancelled except by a written document signed by Seller and Buyer. No course of dealing or performance, usage of trade or failure to enforce any term shall be used to modify the Agreement. If any of these terms is unenforceable, such term shall be limited only to the extent necessary to make it enforceable, and all other terms shall remain in full force and effect. Buyer may not assign or permit any other transfer of the Agreement without Seller's prior written consent. The Agreement shall be governed by the laws of the State of North Carolina without regard to its conflict of laws provisions.





DATE: 11 Sept, 2019  
**TO: Gus Friedman, Matt Winkler – Brown & Caldwell**  
 FROM: Chandler Johnson – World Water Works (WWW)  
 CC: Daniel Thompson, Praveen Yanamandra – WWW  
 Chris McCalib – Treatment Equipment Company (TEC)  
 RE: Information on DEMON® Process – King County South Plant – Rev0

Per your request for design and sizing for a Demon® treatment system based on the **design criteria provided**, please find below our design summary based on the information provided. Below are some graphs showing the typical cycle of a DEMON® treatment system.

**1. DEMON® TREATMENT PROCESS**

Deammonification represents a short-cut in the N-metabolism pathway and comprises of 2 steps. About half the amount of ammonia is oxidized to nitrite and then residual ammonia and nitrite is anaerobically transformed to elementary nitrogen. See this shortcut in the diagram below. By using this process there is no excess oxygen required or external carbon source to achieve nitrogen removal.

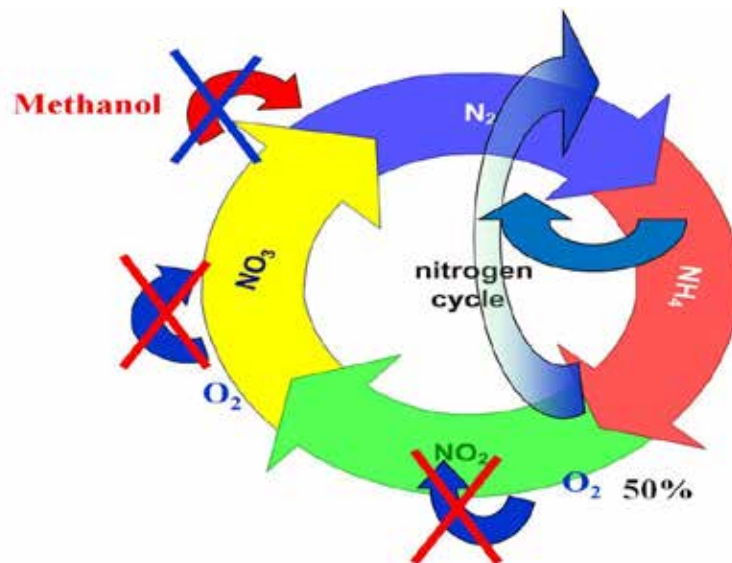

Figure 1 – NITROGEN CYCLE WITH SHORT CUT NITROGEN REMOVAL ADDED

Implementation of the University of Innsbruck pH controlled strategy for the DEMON® process for deammonification of reject water in a single sludge system is what this design is proposed around. The **specific energy demand of the side stream process results in 1.4 kWh per kg ammonia nitrogen removed comparing to about 6.5 kWh of mainstream treatment.** This process is achieving results of greater than 90% at the Strass WWTP (see data presented below). Biomass enrichment and Continuous Demon® -start up is key for this process to achieve its results in a short period of time and this proposal provides the seed sludge and start up assistance to ensure achieving the goal of efficient nitrogen removal.

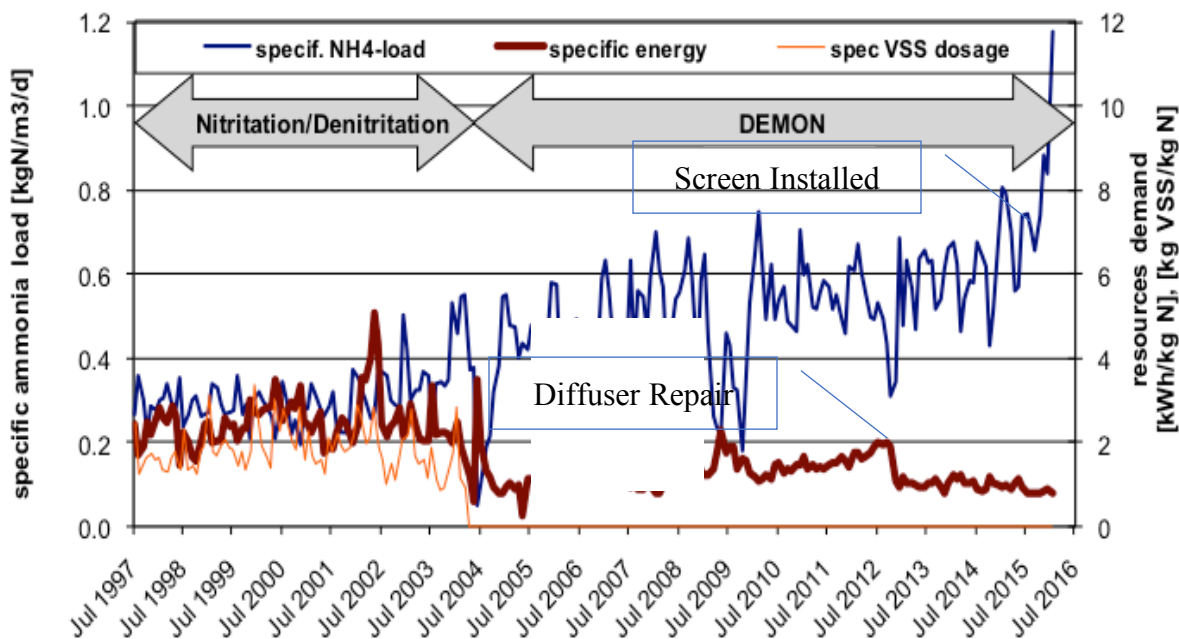

FIGURE 2 – STRASS NITROGEN PROFILE (1997 – 2016) WITH LOADING RATE AND SPECIFIC ENERGY

### **Design Concept**

The overall design concept for is to use two (2) new reactors to create the DEMON® treatment process and EQ tank for the design conditions provided. We envision using a concrete tank of 70 ft long x 40 ft wide x 21 ft SWD for the DEMON® process. New mixers and aeration system will be placed in each reactor for providing the mixing energy for re-suspension of the granules, proper mixing distribution of the influent feed flow and provide the necessary aeration for nitrification. An internal settling zone will be used to settle out the MLSS / Anammox biomass and allow the treated wastewater to be discharged. A single control panel will be provided to control process.

<b>Parameter</b>	<b>Max Month</b>	<b>Peak Day</b>	<b>Max Month (N-1)</b>
TSS, mg/L	< 500	< 500	< 500
TKN, mg/L	1,351	1,337	1,351
Alkalinity, mg/L as CaCO <sub>3</sub>	4,239	4,239	4,239
Temp, °C	25-30	25-30	25-30
Ammonia Loading	7,440 lb/day	11,161 lb/day	1,250 lb/day
TKN Loading	8,000 lb/day	12,000 lb/day	5,208 lb/day
Flow Rate	0.66 MGD	1 MGD	0.5 MGD

We see many advantages in operating the system as a continuous process as it will allow for a lower installed HP for the blowers and feed pumps, not require the Decanter and operate continuously with higher Anammox biomass retention which allows for higher operating loading rates.

We have designed the system based on having removal efficiencies of 85% for ammonia and 75% for TIN for Maximum Month, 60% removal for ammonia and 50% removal for TIN at Peak Day and 34% removal of ammonia and 24% for TIN under Max Month conditions with one (1) basin out of service. However the aeration system is sized based on 5% increase in ammonia removal from the Peak Day Loadings to size the blowers and aeration system. We have also assumed minimum operating temperature of 25C.

Based on the influent alkalinity value of 4,239 mg/L, this will just be able to provide for 80% removal of ammonia and should greater removal of ammonia be desired, sodium bicarbonate will be required.

One note under the Peak Day and Max Month (N-1) conditions, should the DEMON reactors be subjected to the full flow rate of 1 MGD (peak day) or 0.5 MGD under the Max Month (N-1) condition, then free ammonia will play a role in operation of the system. Below are tables of estimated free ammonia values based on operating pH. As we can't predict the operating pH at this stage, we can only offer up the higher the operating pH, the higher the free ammonia concentration in the basin and

the lower the total flow rate the DEMON reactor should be able to treat. The peak flow either reactor can handle is 0.5 MGD.

**Free Ammonia Concentrations under 3 conditions when operating both DEMON reactors:**

<b>Free Ammonia Calculator</b>		<b>pH - 6.7</b>	<b>pH - 6.8</b>	<b>pH - 6.9</b>	<b>pH - 7.0</b>
Peak Day Full Flow	535 mg/L	2.15 mg/L	2.71 mg/L	3.40 mg/L	4.28 mg/L
Peak Day 77% Flow	334 mg/L	1.34 mg/L	1.69 mg/L	2.12 mg/L	2.67 mg/L
Max Month Full flow	202 mg/L	0.81 mg/L	1.02 mg/L	1.28 mg/L	1.61 mg/L

**Free Ammonia Concentration under Max Month (N-1) condition.**

<b>Free Ammonia Calculator</b>		<b>pH - 6.7</b>	<b>pH - 6.8</b>	<b>pH - 6.9</b>	<b>pH - 7.0</b>
Max Month N-1	892 mg/L	3.59 mg/L	4.51 mg/L	5.67 mg/L	7.13 mg/L

The below table is estimated effluent loads for both ammonia and Total Inorganic Nitrogen for all the alternatives reviewed.

<b>Parameter</b>	<b>Max Month</b>	<b>Peak Day</b>	<b>Max Month (N-1)</b>
Effluent NH3-N (lb/day)	1,116	4,464	4,911
Effluent NH3-N (mg/L)	203	535	892
Effluent TIN (lb/day)	1,812	5,385	5,312
Effluent TIN (mg/L)	330	645	996

**DEMON® TANK COMPONENTS**

- a) **Biomass Separation System** – A micro-screen will be used for this project and will have submerged pumps feeding it for a period time to waste out the AOB and NOB bacteria. The waste sludge of AOB and NOB bacteria will be discharged from the system while the underflow (Anammox bacteria) will be returned to the reactor.

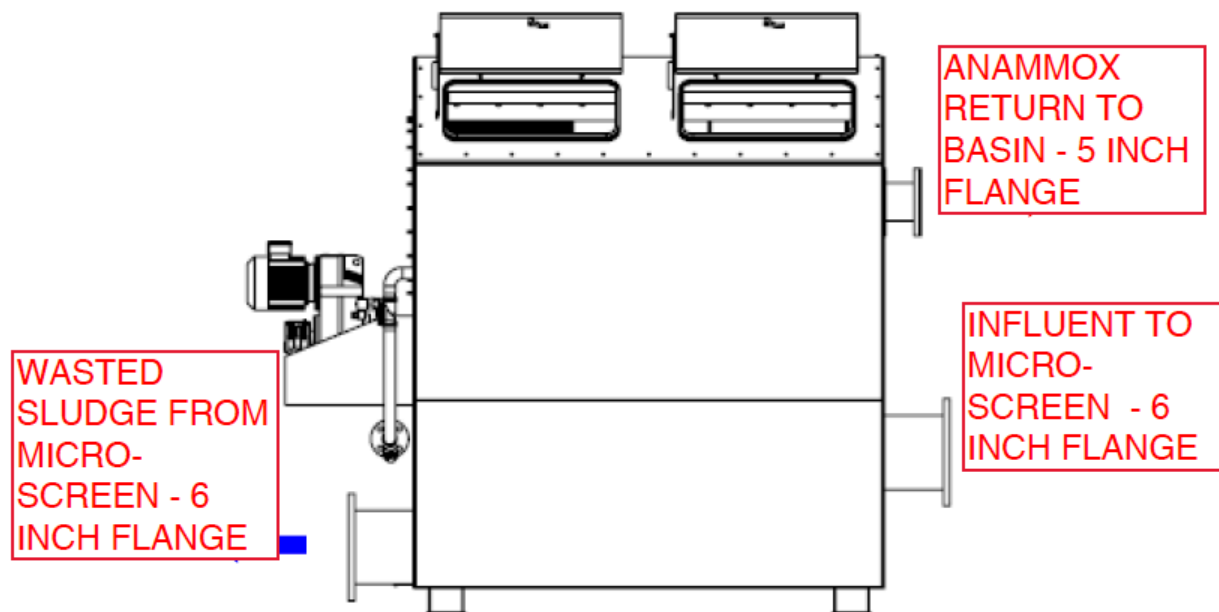

FIGURE 3 – MICRO-SCREEN (INSTALLED), SIDE VIEW

Below are graphs of the loading and % removal of the Anammox treatment system at Strass WWTP in Austria using the microscreen since fall 2015. In February 2016, The specific load was increased to over 1.4 kg/m<sup>3</sup>-day while still maintaining greater than 90% removal of Ammonia-nitrogen.

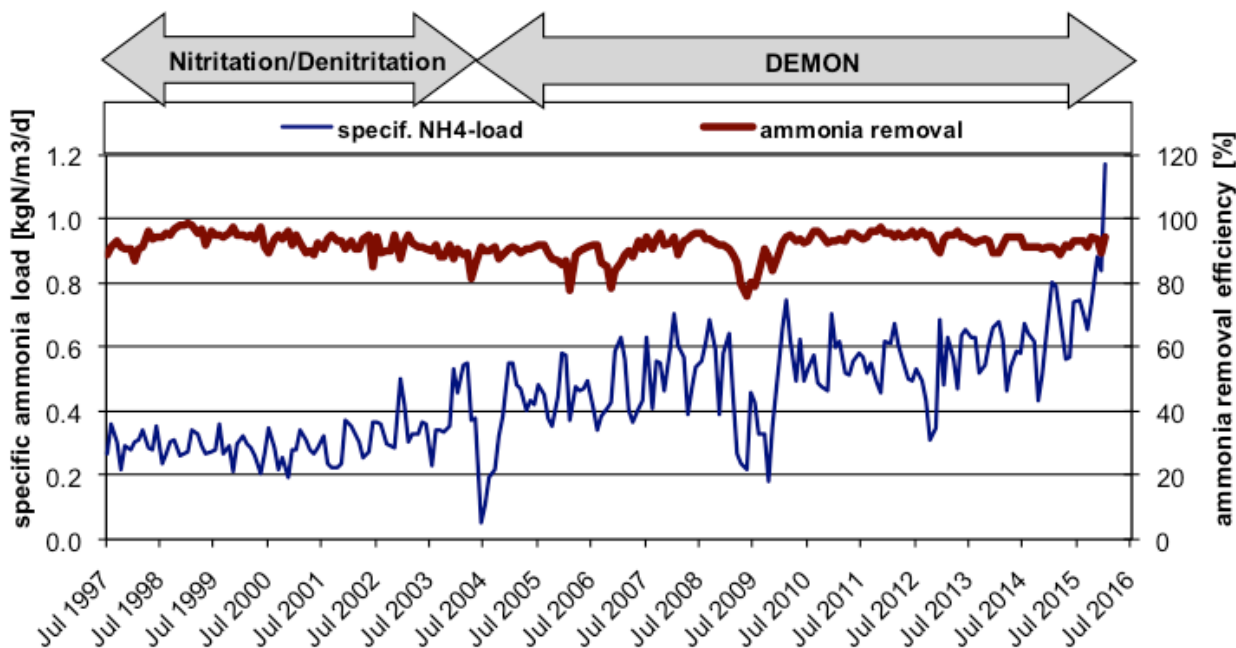

FIGURE 4 – AMMONIA LOAD AND PERCENT REMOVAL VS TIME (1997 – 2016)

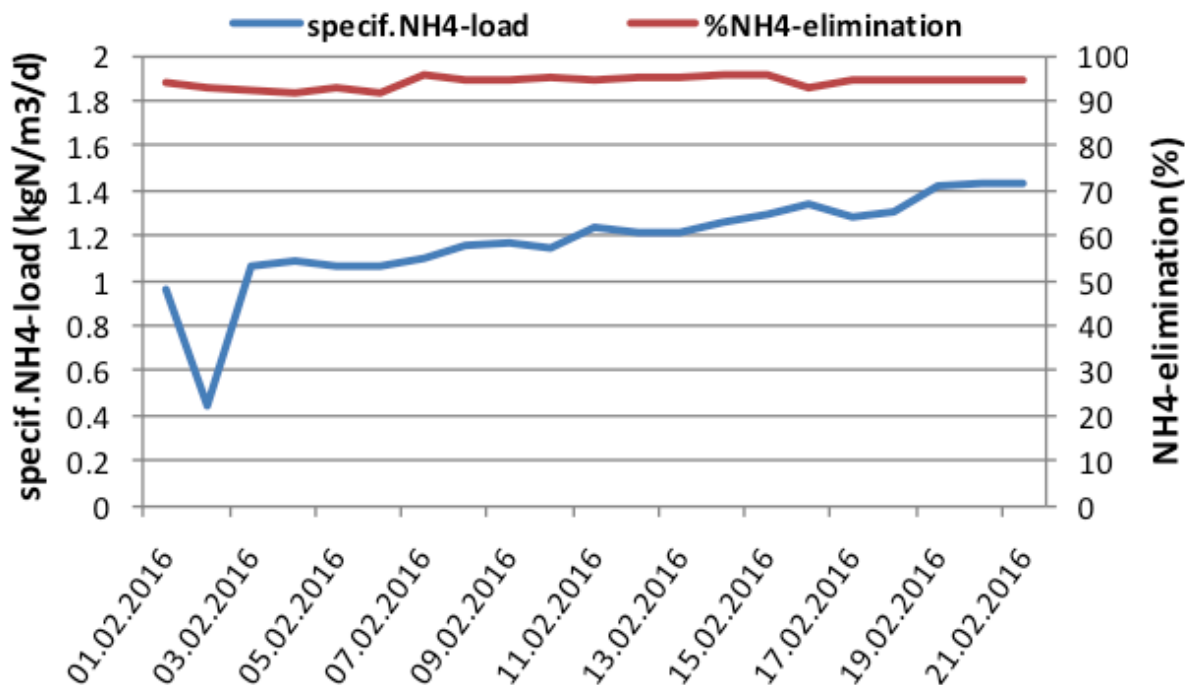

FIGURE 5 – SPECIFIC LOAD AND AMMONIA PERCENT REMOVAL – FEB 2016

- b) **Instrument Float** – the instruments for control of the process will be installed on a float system which will float with the level of the system. One (1) pH probe & one (1) DO probe for control of the overall operation of the process will be provided. A dedicated controller for the DO and pH is our recommendation. The conductivity probe is also to be provided with its own controller. Spare instrument locations will be provided in the instrument float for adding additional analyzers over time.



FIGURE 6 – INSTRUMENT FLOAT EQUIPMENT

- c) **Seed Sludge** – for the quick start-up of the DEMON® treatment process, an adequate amount of seed sludge will be supplied. The seed sludge will be shipped in as dry content possible based on the harvesting technique used and will be added to the systems as they are started up.



FIGURE 7 – SEED SLUDGE SHIPPING CONTAINER



- d) **Aeration System** – The Messner aeration system will be supplied in each tank. The amount of panels is provided in the scope of supply section and is subject to final design.



FIGURE 8 – MESSNER PANEL INSTALLED / AERATION PATTERN TEST

- e) **Side Mounted Mixers** – Landia side mounted mixers will be used to maintain mixing energy within each reactor. The mixers will help re-suspend the “reds” during the start-up phase of each cycle. VFD’s will be provided to allow the mixers to be turned down and save on energy during the overall operation of the cycle.

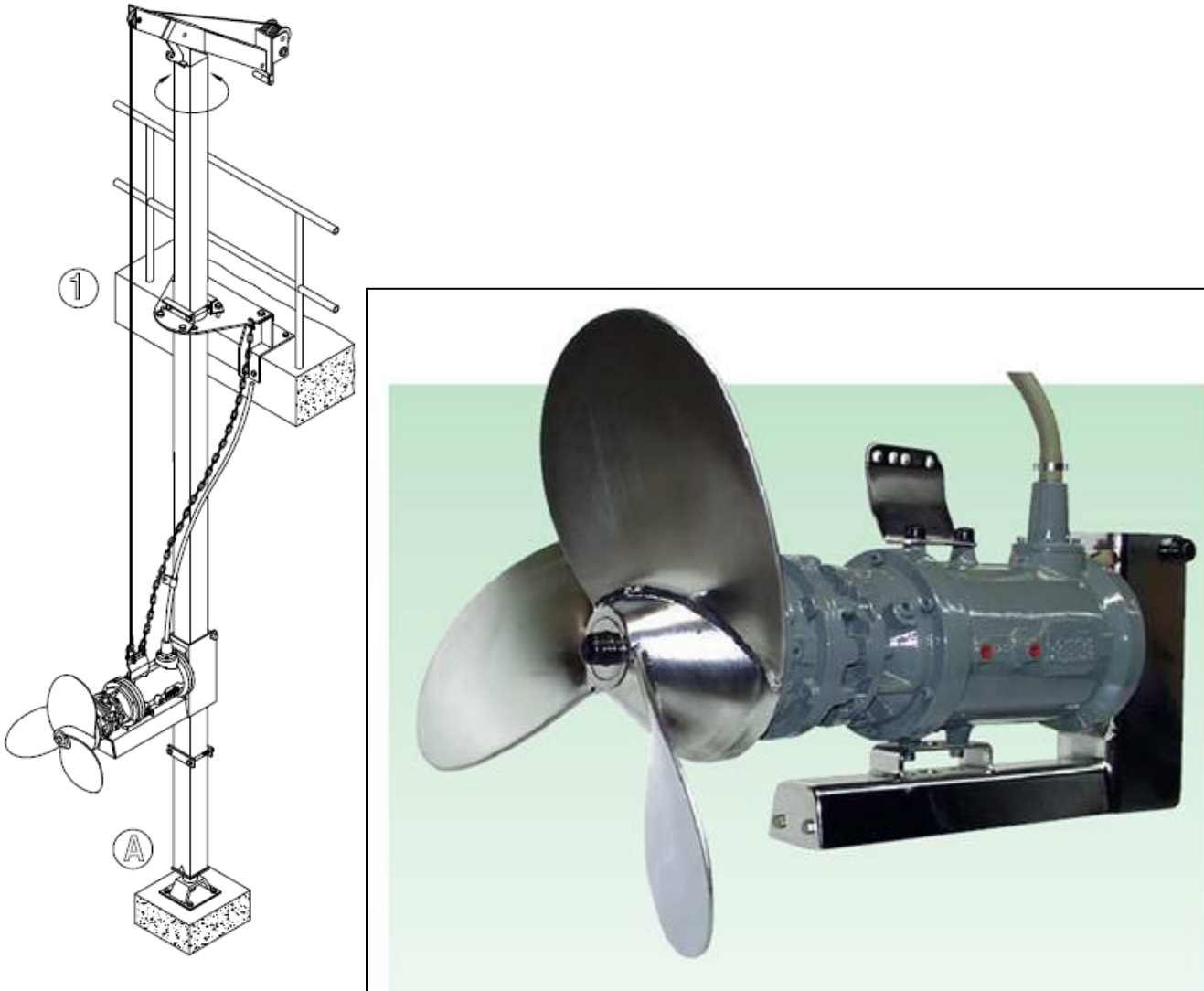
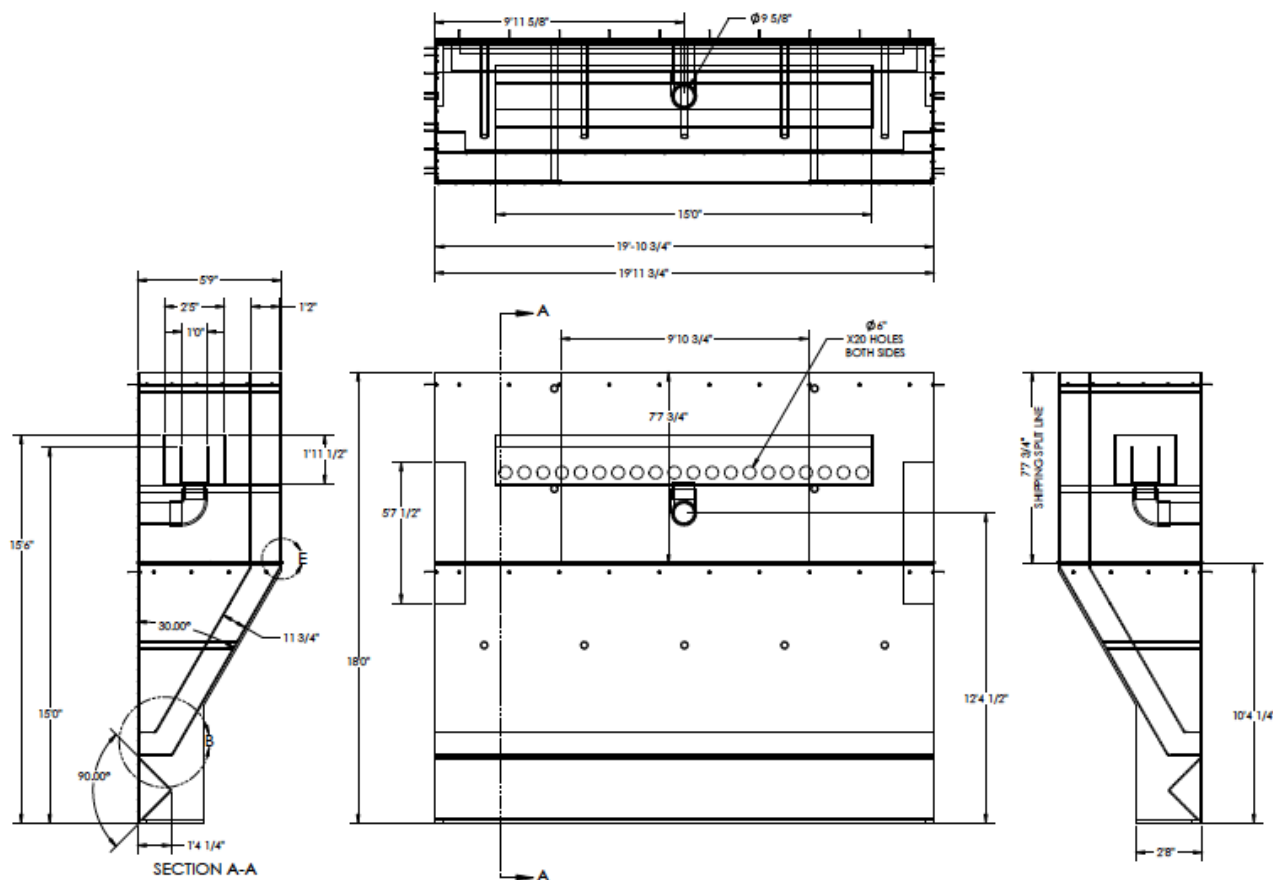

FIGURE 9 – LANDIA MIXER

- f) **Internal Settling Zone** – An internal settling zone will be provided to allow for a continuous operation of the Anammox treatment system. Clarified effluent will be discharged back into the main process while the settled MLSS will be returned to the Anammox reactor. The waste stream enters the vessel and immediately the velocity is reduced to enhance particle separation. The vessel is polypropylene, so the operating pH has no effect on the systems longevity. The “clean” liquid is continuously removed from the top of the settling area and passes through holes into an effluent collection piping system. From the effluent collection piping system, the wastewater gravity feeds out of the system. Heavy solids settle into the bottom where they fall back into the main DEMON® process tank on an automatic basis. The system is compact, robust, cleanable, and does not have moving parts.



**FIGURE 10 - View of the Settling Zone from Top, Front and back sides. To be anchored to outside and back concrete walls.**

g) **Blowers** – Positive displacement blowers capable of providing the necessary turndown for operation of the DEMON® system are to be provided.

<u>Design Case</u>	<u>Model</u>	<u>Air Flow</u>	<u>Est. HP</u>	<u>Est. bHP</u>
1 duty + 1 standby per Process train (4 total provided)	GM 60S	1,308 SCFM	150 HP	89.9 bHP – MM
		1,509 SCFM		98.6 bHP – PD
		1,574 SCFM		108 bHP – MM (N-1)

This blower design will allow the most flexibility in allowing the system have efficient use of blower capacity during start up and low load periods of time. The blowers will each have its own sound enclosure to maintain < 75 db sound rating. Each blower will also be equipped with a variable frequency drive unit to allow efficient turndown of the blower while maintaining the proper dissolved oxygen concentration in the DEMON® reactor.



FIGURE 11 – AERZEN BLOWER WITH SOUND ENCLOSURE

h) **Documentation / Design / License** – All necessary documentation and design information will be provided as well as a license for treating the Maximum Month Loads.

## 2. CONTROLS

World Water Works provides pre-wired control panels to optimally control all equipment provided within the scope of this proposal. World Water Works includes an Ethernet connection with the control panel to allow remote access to the program and to assist in troubleshooting.

### INSTRUMENTATION

Electrical Enclosure	<b>Hoffman, NEMA 4</b>
PLC	<b>Allen Bradley</b>
Software	<b>Allen Bradley</b>
Touchscreen	<b>15 inch Color Touch Screen</b>

### ADDITIONAL OPTIONS PROVIDED

**Remote Operation Capability**

**UL Listed Panel**



FIGURE 12 – CONTROL PANEL WITH PLC

**PLC Panel** – The PLC panel and control program is the heart of the DEMON® process and its integral to our scope of supply. The PLC program will have each reactor created as a separate reactor. The reactor will have independent feed of raw centrate, aeration and mixing time. A touch panel with remote access is standard for allowing WWW access to the system and provides operational oversight.

**DESIGN FOR 25C – Maximum Month**

<b>Influent Flow and Wastewater Characteristics</b>	<b>Design</b>		<b>Design</b>	
	Wastewater temperature in DEMON® Anammox-tank	25	°C	77
Daily water flow	2,498	m <sup>3</sup> /d	0.660	MGD
Ammonia (NH <sub>4</sub> -N) Load	3,375	kg/d	7,440	lb/day
Ammonia (NH <sub>4</sub> -N) Concentration	1,351	mg/L	1,351	mg/L
Soluble COD, degradable (estimate)	500	mg/L	500	mg/L
Suspended Solids Concentration (TSS)	500	mg/L	500	mg/L
Soluble COD, degradable Load	1,249	kg/d	2,754	lb/day
Suspended Solids Load (TSS)	1,249	kg/d	2,754	lb/day
Alkalinity Concentration	4,239	mg/L	4,239	mg/L
Alkalinity Load	10,591	kg/d	23,348	lb/day
<b>DEMON® Anammox Tank Information</b>				
Number of tanks	2	in parallel	2	in parallel
Max. water depth	6.40	m	21.0	ft
Total volume per DEMON® Anammox Reactor	1664	m <sup>3</sup>	58,761	ft <sup>3</sup>
Length of Each DEMON® Anammox Treatment Reactor	21.3	m	70	ft
Width of Each DEMON® Anammox Treatment Reactor	12.2	m	40	ft
Total Treatment Volume Provided	3,328	m <sup>3</sup>	117,522	ft <sup>3</sup>
<b>Influent Feeding Design</b>				
Feeding pump per tank	76	m <sup>3</sup> /h	336	gpm
<b>Design of aeration system</b>				
<b>Biological Oxygen Requirements System Design</b>				
Actual Oxygen Requirements (AOR), operating conditions	6,200	kg O <sub>2</sub> /d	13,669	lb O <sub>2</sub> /d
Actual Oxygen Required (AOR) in DEMON® Anammox tank	185	kg O <sub>2</sub> /h	407	lb O <sub>2</sub> /h
<b>Aeration System &amp; Blower Design Air Flow Requirements</b>				
Design Air Flow (per DEMON® Anammox-tank)	2,223	Nm <sup>3</sup> /h	1,308	SCFM
Design Air Flow (per ALL TANKS)	4,447	Nm <sup>3</sup> /h	2,617	SCFM

Air flows are based on 21 ft operating water level and discharge pressure of 10.5 psig

Rough Footprint would be two (2) basins at 40 ft wide x 70 ft long x 21 ft SWD.

**DESIGN FOR 25C – Peak Day**

<b>Influent Flow and Wastewater Characteristics</b>	<b>Design</b>		<b>Design</b>	
Wastewater temperature in DEMON® Anammox-tank	25	°C	77	F
Daily water flow	3,785	m <sup>3</sup> /d	1,000	MGD
Ammonia (NH <sub>4</sub> -N) Load	5,062	kg/d	11,161	lb/day
Ammonia (NH <sub>4</sub> -N) Concentration	1,337	mg/L	1,337	mg/L
Soluble COD, degradable (estimate)	500	mg/L	500	mg/L
Suspended Solids Concentration (TSS)	500	mg/L	500	mg/L
Soluble COD, degradable Load	1,893	kg/d	4,173	lb/day
Suspended Solids Load (TSS)	1,893	kg/d	4,173	lb/day
Alkalinity Concentration	4,239	mg/L	4,239	mg/L
Alkalinity Load	16,046	kg/d	35,376	lb/day
<b>DEMON® Anammox Tank Information</b>				
Number of tanks	2	in parallel	2	in parallel
Max. water depth	6.40	m	21.0	ft
Total volume per DEMON® Anammox Reactor	1664	m <sup>3</sup>	58,761	ft <sup>3</sup>
Length of Each DEMON® Anammox Treatment Reactor	21.3	m	70	ft
Width of Each DEMON® Anammox Treatment Reactor	12.2	m	40	ft
Total Treatment Volume Provided	3,328	m <sup>3</sup>	117,522	ft <sup>3</sup>
<b>Influent Feeding Design</b>				
Feeding pump per tank	116	m <sup>3</sup> /h	509	gpm
<b>Design of aeration system</b>				
<b>Biological Oxygen Requirements System Design</b>				
Actual Oxygen Requirements (AOR), operating conditions	7,135	kg O <sub>2</sub> /d	15,730	lb O <sub>2</sub> /d
Actual Oxygen Required (AOR) in DEMON® Anammox tank	212	kg O <sub>2</sub> /h	468	lb O <sub>2</sub> /h
<b>Aeration System &amp; Blower Design Air Flow Requirements</b>				
Design Air Flow (per DEMON® Anammox-tank)	2,559	Nm <sup>3</sup> /h	1,506	SCFM
Design Air Flow (per ALL TANKS)	5,118	Nm <sup>3</sup> /h	3,012	SCFM



**DESIGN FOR 25C – Max Month (N-1)**

<b>Influent Flow and Wastewater Characteristics</b>	<b>Design</b>		<b>Design</b>	
Wastewater temperature in DEMON® Anammox-tank	25	°C	77	F
Daily water flow	1,749	m <sup>3</sup> /d	0.462	MGD
Ammonia (NH <sub>4</sub> -N) Load	2,362	kg/d	5,208	lb/day
Ammonia (NH <sub>4</sub> -N) Concentration	1,351	mg/L	1,351	mg/L
Soluble COD, degradable (estimate)	500	mg/L	500	mg/L
Suspended Solids Concentration (TSS)	500	mg/L	500	mg/L
Soluble COD, degradable Load	874	kg/d	1,928	lb/day
Suspended Solids Load (TSS)	874	kg/d	1,928	lb/day
Alkalinity Concentration	4,239	mg/L	4,239	mg/L
Alkalinity Load	7,413	kg/d	16,344	lb/day
<b>DEMON® Anammox Tank Information</b>				
Number of tanks	1	in parallel	1	in parallel
Max. water depth	6.40	m	21.0	ft
Total volume per DEMON® Anammox Reactor	1664	m <sup>3</sup>	58,761	ft <sup>3</sup>
Length of Each DEMON® Anammox Treatment Reactor	21.3	m	70	ft
Width of Each DEMON® Anammox Treatment Reactor	12.2	m	40	ft
Total Treatment Volume Provided	1,664	m <sup>3</sup>	58,761	ft <sup>3</sup>
<b>Influent Feeding Design</b>				
Feeding pump per tank	107	m <sup>3</sup> /h	471	gpm
<b>Design of aeration system</b>				
<b>Biological Oxygen Requirements System Design</b>				
Actual Oxygen Requirements (AOR), operating conditions	3,728	kg O <sub>2</sub> /d	8,220	lb O <sub>2</sub> /d
Actual Oxygen Required (AOR) in DEMON® Anammox tank	222	kg O <sub>2</sub> /h	489	lb O <sub>2</sub> /h
<b>Aeration System &amp; Blower Design Air Flow Requirements</b>				
Design Air Flow (per DEMON® Anammox-tank)	2,674	Nm <sup>3</sup> /h	1,574	SCFM

### **WWW Scope of Supply**

- Design & Engineering for System
- Two (2) – 40 ft wide x 10 ft deep x 18 ft tall internal settling zone made from Polypropylene
- One Hundred Fifty-Two (152) Messner Aeration panels for the reactors (76 per reactor)
- Four (4) SS 304L Drop pipe with manifold to feed Messner panels (2 per reactor)
- Two (2) DEMON® Biomass Separation Systems
- Three (3) submersible pumps (two duty + one standby) rated at 50 gpm and 5 HP motor with VFD's on each pump (operated 8 hrs per day)
- Three (3) Radar type level control for each DEMON® Tank & EQ Tank
- Four (4) influent feed pumps to the DEMON® reactor each rated for 76 gpm with VFD's on each pump. (operated 12 - 24 hrs per day) (2 duty + 2 standby)
- Two (2) Positive Displacement blowers (1,575 SCFM each) with VFD's on each blower (150 HP motors) (operated 14 hrs per day at design load) – (2 Duty + 2 Standby)
- Six (6) – 9.0 HP side mounted mixers with VFD's for each mixer (operated 6 hr/day) (3 per tank)
- Seed Sludge for start-up of system delivered to the site
- DEMON® Control program with panel with VFD's for blowers, submersible pump and mixers
- Two (2) pH and DO probe with two (2) SC1000 controller
- Two (2) Conductivity probe with two (2) SC200 controller
- Two (2) Air flow insertion meter and six (6) water flow magnetic meters
- Inspection, start up and training services (10 trips / 40 days)
- 3-4 months of off-site / remote monitoring services
- **Estimated Price for above scope of supply: \$3,800,000 USD**

### **Items not included:**

Tankage for EQ tank sized for 2 hours HRT (for systems with dewatering 24 hours per day or 8 – 12 hours for systems with dewatering 8 – 16 hours per day)

DEMON® tanks

Unloading, storage, installation of equipment

Electrical connections and interconnecting piping



Proposal  
King County South Plant, WA

BIOSTYR®

Project No. 5700147909



Submitted to: Matt Winkler  
Brown & Caldwell

Submitted by: Ashley Garbett  
Biological Applications Engineer

Date: 10/17/2019

*This document is confidential and may contain proprietary information.  
It is not to be disclosed to a third party without the written consent of Veolia Water Technologies.*

**Veolia Water Technologies, Inc. dba Kruger**  
4001 Weston Parkway  
Cary, NC 27513  
tel. +1 919-677-8310 • fax +1 919-677-0082  
[www.veoliawatertech.com](http://www.veoliawatertech.com)

**Water Technologies**

## Company Introduction

With 160 years of expertise in the areas of water, energy and waste, Veolia applies its capacity for innovation to pursuing human progress and wellbeing, and improving the performance of businesses and regions. To make the switch from a resource consumption rationale to a use-and-recover approach in today's circular economy, Veolia designs and implements solutions aimed at improving access to resources while at the same time protecting and renewing those same resources.

As the world's leading provider of environmental solutions to cities and businesses, we blend our skills in operations, engineering and technology with an unrivaled international network to offer a wide range of service delivery models to our clients. Whether we're reducing our customers' energy consumption to control costs or helping them meet strict water quality standards, we provide performance and reliability guarantees and measure our work by our customers' satisfaction.

We specialize in providing advanced and differentiating technologies that range from biological nutrient removal to mobile surface water treatment. The ACTIFLO® Microsand Ballasted Clarifier, BioCon® Biosolids Dryer, BIOSTYR®/BIOSTYR DUO™ Biological Aerated Filter (BAF) and Hydrotech Discfilter are just a few of our innovative technologies. Based on this expertise, we believe that we have developed the best solution for your application.



10 MGD Tahoe-Truckee SD BIOSTYR - Truckee, CA

## BIOSTYR® Process Overview

The BIOSTYR® systems are up-flow submerged fixed-film processes that biologically treat carbonaceous and nitrogenous wastes (CBOD,  $\text{NH}_4\text{-N}$ ,  $\text{NO}_3\text{-N}$ ) and remove insoluble pollutants (TSS) through the filtering mechanism of the process. A distinguishing feature of these processes is the ability of the submerged media to provide for both biological treatment and filtration in a single step.



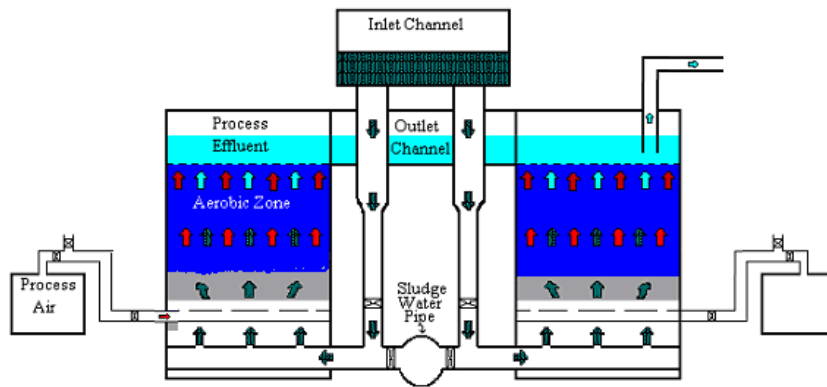

The above figure depicts the general flow path of water through a BIOSTYR® or BIOSTYR® DUO system. Influent wastewater is typically pumped to a common inlet feed channel above the BIOSTYR® cells where it flows down to the individual cells by gravity, although direct pumping to the cells is also common.



Interior of BIOSTYR Cell

Within each BIOSTYR® cell, the wastewater flow must be distributed evenly across the bottom of the cell, which is accomplished most commonly by a set of distribution troughs cast into the bottom of the cell. As wastewater enters a cell, water flows upwards through the filter media, which may vary in depth from 2.0 to 4.2 m depending on the media used and the application. Biological growth on the surface of the media provides treatment of the wastewater as it flows through the cells. Ceiling plates with regularly spaced nozzles are used to retain the filter media. The nozzles allow the treated water to enter a common water reservoir above the filters, which in turn is used to provide water during backwash sequences.

The media contained in the cells is composed of specially manufactured high-density polystyrene beads (BIOSTYRENE) covered by active biomass.

In a system designed for nitrification only, a process air grid is placed below the filter media so that the entire filter bed is aerobic. BOD is oxidized by the biomass in the lower section of the filter. As the wastewater continues up the filter, additional BOD is consumed. When the BOD:TKN ratio falls below a certain limiting level, nitrification occurs, thereby converting the ammonia to nitrate.





Growth of biomass and the retention of suspended solids in the filter media make periodic backwashing necessary. The BIOSTYR® process is designed for a backwash interval of 24 hours or more. The backwash sequence is performed automatically and is triggered either when a preset time limit has expired or when the head loss across the filter exceeds a pre-determined setpoint. Water from the common treated water reservoir flows down through the filter by gravity, thereby expanding the media bed. The air grid located below the media is used to supply scouring air during the backwash sequence. This grid is composed of perforated stainless steel piping that allows air to be injected into the filters.

Like other filtration processes, high TSS and BOD concentrations in the influent waste stream can increase the rate of clogging. If the influent waste stream contains high levels of TSS or BOD, it is desirable to install clarification to partially treat the wastewater.

The BIOSTYR® process provides several significant improvements over other fixed film systems. First, using a floating media bed in conjunction with an up-flow system ensures that the nozzles used to retain the media are only in contact with treated water. This prevents the nozzles from clogging and provides easy access for nozzle maintenance or replacement.

Second, the counter-current backwashing sequence ensures efficient removal of accumulated solids. During backwashing sequences, the downward flow expands the filter media and utilizes gravity to aid in flushing solids from the bottom of the filter. Additionally, the backwash water is supplied from a common reservoir above the filter cells, eliminating the costs associated with backwash pumping. Finally, used backwash water is collected in drainpipes at the bottom of the filters. It is not exposed to the atmosphere, so the potential for odor problems is dramatically reduced.

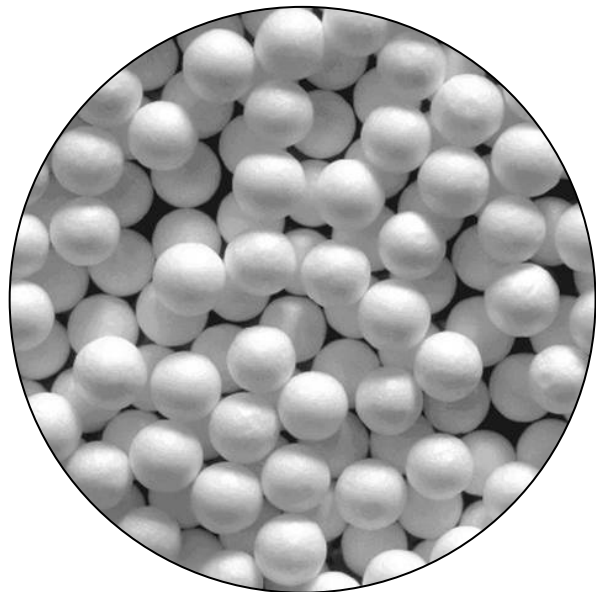

BIOSTYRENE Media



---

## Design Summary

The design assumes that the raw influent wastewater is biodegradable, no toxic compounds are present, sufficient alkalinity is available to avoid pH depressions, that the COD/BOD ratio is between 1.7 and 2.3, and that none of the equipment provided would be used in a classified area (e.g. Class 1, Division 1 or Class 1, Division 2) except for methanol feed equipment.

Secondary BIOSTYR® cells do not require dedicated influent screens. Kruger recommends the site have 10 mm fine screening, bar or mesh screens, which could occur upstream of the filters, for instance at the plant headworks. Kruger understands that influent will be fed to the BIOSTYR® system by pumping.

The secondary effluent characteristic data are summarized in Tables 1. The targeted permit limits in tertiary effluent are summarized in Table 2. The detailed cell information, along with other important process design parameters are summarized in Tables 3, 4, 5, and 6. The estimated concrete volumes are summarized in Tables 7 and 8.





Parameters	2A	4C		4D				4E	
	2A	4C	4C Rev1	4D	4D	4D Rev1	4D Rev1	4E NDN+PDN	4E NDN+PDN
Preceding Process	MLE Process	MLE Process	MLE Process	C removal CAS	Tertiary N BIS	C removal CAS	Tertiary N BIS	CEPT	Classical NDN
BAF Process	Tertiary DN BIS	Tertiary DN BIS	Tertiary DN BIS	Tertiary N BIS	Tertiary DN BIS	Tertiary N BIS	Tertiary DN BIS	Classical NDN	Post DN
Controlling Condition	Start of Summer [1]	Winter Condition [2]	Winter Condition [3]	Winter Condition [4]	Winter Condition [5]	Winter Condition [6]	Winter Condition [7]	Winter Condition [8]	Winter Condition [9]
BAF Effluent Goal	NOx-N < 6.0 mg/L [10]	NOx-N < 2.0 mg/L [11]	NOx-N < 1.0 mg/L [12]	NH3-N < 1.0 mg/L [13]	Ox-N < 2.0 mg/L [14]	NH3-N < 1.0 mg/L [15]	Ox-N < 2.0 mg/L [16]	n/a [17]	TIN < 1.5 [18]
Monthly Avg. (MGD)									
Max Month (MGD)	97.88	144	144	144	144	144	144	144	144
Peak Flow (MGD)			222			247	247	247	247
Temp	15.30	13.1	13.1	13.1	13.1	13.1	13.1	13.1	13.1
CBOD			30			30		190	
CBOD									
TSS			30			30		105	
TSS									
NH3-N (mg/L)				38		38		33	
NH3-N Load (lb/day)				45,769		45,769		39,632	
NOx-N mg/L	23.84	25	25		25		36		16
NOx-N Load (lb/day)	19,461	30,024	30,024		30,024		43,235		19,215
# Batteries	1	1	1	2	1	2	2	3	1
Cells / Battery	10	18	18	12	18	15	12	22	12
# cells	10	18	18	24	18	30	24	66	12
Cell Area (ft2)	2,581	2,581	2,581	2,581	2,581	2,581	2,581	2,581	2,581
<b>Estimated Total Footprint</b>	<b>140' x 245'</b>	<b>140' x 425'</b>	<b>140' x 425'</b>	<b>140' x 580'</b>	<b>140' x 425'</b>	<b>140' x 760'</b>	<b>140' x 570'</b>	<b>140' x 1338'</b>	<b>140' x 285'</b>
Cell Depth (ft)	9.80	9.80	9.80	11.48	9.80	11.48	9.80	11.50	8.20
Total Area (ft2)	25,810	46,458	46,458	61,944	46,458	77,430	61,944	170,346	30,972
Total Media V (ft3)	252,938	455,288	455,288	711,117	455,288	888,896	607,051	1,958,979	253,970
Backwash Volume/Cell (ft3)	63,235	63,235	63,235	74,075	63,235	74,075	63,235	74,204	52,911
Backwash Return Time (min)	75	75	60	60	75	60	75	75	75
Peak BW Return Rate (GPM)	6,307	6,307	7,884	9,235	6,307	9,235	6,307	7,401	5,277
Air Demand (SCFM)						43,700		92,300	
Max Month Hyd. Loading (GPM/ft2)	2.88	2.29	2.32	1.76	2.49	1.41	1.87	0.67	3.60
Max Month Hyd. Loading (m/hr)	7.04	5.59	5.68	4.31	6.08	3.45	4.56	1.63	8.81
Peak Hyd. Loading (GPM/ft2)	0.24	0.14	0.349	0.15	0.14	2.33	2.87	1.05	5.71
	0.60	0.33	8.53	0.36	0.33	5.71	7.02	2.57	13.96
Max Month NH3-N load (lb/day/kcf)				64.4		51.5		20	
Max Month NOx-N load (lb/day/kcf)	60.8	65.9	65.9		65.9		71.2		75.7
<b>Budgetary Pricing:</b>	<b>Option 2A : \$18,000,000</b>	<b>Option 4C : \$30,000,000</b>	<b>Option 4C R1: \$30,000,000</b>	<b>Option 4D (N + DN) : \$70,000,000</b>		<b>Option 4D R1 (N + DN) : \$90,000,000</b>		<b>Option 4E (NDN + DN) : \$130,000,000</b>	

---

## Scope of Supply

Kruger is pleased to present our scope of supply which includes process engineering design, equipment procurement, and field services required for the proposed treatment system, as related to the equipment specified. The work will be performed to Kruger's high standards under the direction of a Project Manager. All matters related to the design, installation, or performance of the system shall be communicated through the Kruger representative giving the Engineer and Owner ready access to Kruger's extensive capabilities.

### **Process and Design Engineering**

Kruger provides comprehensive process engineering and design support for our BIOSTYR® system, including but not limited to:

- Detail process design assistance
- Provision of drawings and specifications for use by the consulting engineer in developing the detailed plant design.
- Provision of calculations and other data and attendance at meetings as necessary during state approval processes.
- Shop drawing submittal for Engineer's review and approval. Includes detailed equipment information for all equipment supplied by Kruger.
- Equipment installation instructions for all equipment supplied by Kruger, as well as detailed Operations and Maintenance Manuals.

### **Field Services**

Kruger provides very comprehensive support of our systems throughout the installation and start-up period. Our experienced staff of field service personnel will inspect the installation of each component and assist in mechanical start-up, and will typically include direct manufacturer assistance for key pieces of equipment. Our dedicated team of instrumentation and controls engineers will provide calibration and start-up of all instrumentation and onsite verification of proper functioning of our PLC programming and operator interface systems. Process Engineers will assist in verification of program functions, start-up of the process, any process performance testing and optimization of the process. Kruger personnel will also provide onsite instruction of the operations staff in the proper operation of the Kruger supplied equipment and systems. Together, Kruger's estimate of on-site field service for this project includes:

- A minimum of 60 man-days field support during the construction and start-up of the facility. Included in this period is time for training Owner's staff in the proper operation and maintenance of the BIOSTYR® facility.
- A minimum of 30 man-days field support during performance testing and to provide ongoing process support, supplemental training, and troubleshooting.
- Field support from direct manufacturers for major equipment items purchased and supplied by Kruger, including blowers, pumps, valves, compressors and instruments.



## **BIOSTYR® System Equipment**

Kruger will supply the following equipment associated with the system:

Typical Nitrification Stage Mechanical Equipment Items	Equipment Description
Nozzle Slabs	Precast reinforced concrete. For all BIOSTYR Cells.
Nozzle Slab Manway	Two (2) per cell.
Nozzles and Gaskets	For all BIOSTYR Cells
Pipe Gallery Manway	One (1) per cell. Stainless Steel.
Site Glasses	One (1) per cell. Stainless Steel. Cast in concrete pipe gallery wall of cells.
Pressure Port Inserts	Two (2) per cell.
Sample Ports	Four (4) Nit cells equipped with 3 ports each. For profile sampling.
Process/Backwash Aeration Grid	One (1) per cell, including inlet header, purge header, lateral distribution lines, couplings, wall brackets, floor stand support structure, and wall inserts. Piping is stainless steel. <u>Anchor bolts provided by Contractor.</u>
Biostyrene Media	Refer to Table. <u>Media installation is included.</u>
Aeration Blowers	Centralized Process Air Blowers shared between all Nitrification cells.
Backwash Pipes or Channel Cover Plates	One (1) set per cell. <u>Anchor bolts provided by Contractor.</u>
Backwash Sludge Pumps	Three (3) backwash pumps per battery. To transfer backwash water from the backwash mud well to primary treatment facility, including necessary check and isolation valves.
Automatic Process Valves	One (1) automated, open/close inlet water valve per cell One (1) manual isolation valve for water inlet pipe per cell Three (3) automated, open/close backwash valves per cell One (1) manual isolation inlet air valve per cell One (1) automated, open/close inlet air valve per cell One (1) automated, open/close backwash air grid purge valve per cell Two (2) common automated, modulating backwash header valves for each stage
Cell Influent Slide Gate Assemblies	One (1) Influent flow distribution orifice slide-plate and frame for each BIOSTYR® cell influent box.
Cell Effluent Slide Gate Assemblies	Two (2) slide gates for each cell in each stage. For the effluent ports in each BIOSTYR cell.
Instrument Air System	Two (2) common air compressors for each stage to provide compressed air for pneumatic actuators. System includes backup/duplex compressor, receiving tank, refrigerated air dryer, controller, regulator, and necessary filters.



Typical Nitrification Stage Mechanical Equipment Items	Equipment Description
Spare Parts	<p>10% extra Nozzles, Nozzle Inserts, Gaskets, Fill Ports and Fill Port Inserts are included in Kruger's Scope of supply.</p> <p>10% Extra media is included in Kruger's scope of supply to compensate for compression of media during shipping and installation.</p> <ul style="list-style-type: none"> <li>○ Three (3) Spare filter elements and one (1) spare set V-belts for air scour blowers.</li> </ul>
Nitrification Stage Instrumentation and Controls Equipment Items*	Description
Submersible Pressure Transducer	Liquid Level Measurement. One (1) in each Nit. Effluent channel and Nit. backwash tanks, for a total of Four (4).
pH/Temperature Probe	One (1) in each Nitrification influent and effluent channels, for a total of four (4)
DO Probe (LDO)	Two (2) in each Nitrification influent and effluent channels, for a total of eight (8)
Thermal Mass Flowmeter	One for each Nitrification cell.
NH <sub>3</sub> -N Analyzer	Two (2) NH <sub>3</sub> -N Analyzers, one for BIOSTYR® N Influent Sample and BIOSTYR® N stage Effluent. Must be located indoors in a climate controlled environment
Pressure Transmitter	One (1) for each BIOSTYR cell.
PLC Control Cabinet	NEMA 12; ControlLogix PLC; Panelview HMI; 120V Feed

\* All instruments supplied with integral signal converter/transmitter where applicable. Kruger will calibrate and startup Instruments supplied by Kruger. Instruments supplied by others will require calibration and start-up by others.



Typical Denitrification Stage Mechanical Equipment Items	Equipment Description
Nozzle Slabs	Precast reinforced concrete. For all BIOSTYR Cells.
Nozzle Slab Manway	Two (2) per cell.
Nozzles and Gaskets	For all BIOSTYR Cells
Pipe Gallery Manway	One (1) per cell. Stainless Steel.
Site Glasses	One (1) per cell. Stainless Steel. Cast in concrete pipe gallery wall of cells.
Pressure Port Inserts	Two (2) per cell.
Sample Ports	Four (4) Denit cells equipped with 3 ports each. For profile sampling.
Backwash Aeration Grid	One (1) per cell, including inlet header, purge header, lateral distribution lines, couplings, wall brackets, floor stand support structure, and wall inserts. Piping is stainless steel. <u>Anchor bolts provided by Contractor.</u>
Biostyrene Media	Refer to Table 3. <u>Media installation is included.</u>
Backwash Blowers	Shared with Nit Stage centralized blower station.
Backwash Pipes or Channel Cover Plates	One (1) set per cell. <u>Anchor bolts provided by Contractor.</u>
Backwash Sludge Pumps	Three (3) backwash pumps per battery. To transfer backwash water from the backwash mud well to primary treatment facility, including necessary check and isolation valves.
Automatic Process Valves	<p>One (1) automated, open/close inlet water valve per cell</p> <p>One (1) manual isolation valve for water inlet pipe per cell</p> <p>Three (3) automated, open/close backwash valves per cell</p> <p>One (1) manual isolation inlet air valve per cell</p> <p>One (1) automated, open/close inlet air valve per cell</p> <p>One (1) automated, open/close backwash air grid purge valve per cell</p> <p>Two (2) common automated, modulating backwash header valves for each stage</p>
Cell Influent Slide Gate Assemblies	One (1) Influent flow distribution orifice slide-plate and frame for each BIOSTYR® cell influent box.
Cell Effluent Slide Gate Assemblies	Two (2) slide gates for each cell in each stage. For the effluent ports in each BIOSTYR cell.
Instrument Air System	Two (2) common air compressors for each stage to provide compressed air for pneumatic actuators. System includes backup/duplex compressor, receiving tank, refrigerated air dryer, controller, regulator, and necessary filters.



Typical Denitrification Stage Mechanical Equipment Items	Equipment Description
Spare Parts	<p>10% extra Nozzles, Nozzle Inserts, Gaskets, Fill Ports and Fill Port Inserts are included in Kruger's Scope of supply.</p> <p>10% Extra media is included in Kruger's scope of supply to compensate for compression of media during shipping and installation.</p> <ul style="list-style-type: none"> <li>○ Three (3) Spare filter elements and one (1) spare set V-belts for air scour blowers.</li> </ul>
Typical Denitrification Stage Instrumentation and Controls Equipment Items*	Description
Submersible Pressure Transducer	Liquid Level Measurement. One (1) in each Denit. Effluent channel and Denit. backwash tanks, for a total of Four (4).
Thermal Mass Flowmeter	One for each Denitrification battery, two (2) total.
Magnetic Flowmeter	One for each Denitrification cell feed pipe.
Nitrate Analyzer	Two (2) Nitrate Analyzers, one for BIOSTYR® N stage Effluent, the second one for BIOSTYR® DN Effluent .
Pressure Transmitter	One (1) for each BIOSTYR cell.
PLC Control Cabinet	NEMA 12; ControlLogix PLC; Panelview HMI; 120V Feed

\* All instruments supplied with integral signal converter/transmitter where applicable. Kruger will calibrate and startup Instruments supplied by Kruger. Instruments supplied by others will require calibration and start-up by others.



## **Scope of Supply BY INSTALLER/PURCHASER**

The following items are NOT included in the scope of supply for the system and should be provided for by the Installing Contractor/Purchaser of the system *unless explicitly stated as included in the above scope of supply*. These items include, but are not necessarily limited to, the following items:

- Concrete foundations, pads, tanks, structural components, walkways, handrail, grating and covers,
- Equipment installation, piping to and from the system, interconnecting piping, manual isolation valves or gates, anchor bolts, epoxy/adhesive for anchors,
- Raw influent wastewater pumping, influent screening and grit removal facilities,
- Solids handling/disposal system, WAS pumps, digester equipment,
- Effluent holding tanks/equipment, disinfection equipment, outfalls,
- Chemical addition systems, containment, odor control equipment, laboratory systems or equipment,
- Overhead gantries or cranes,
- Motor control center, motor starters, adjustable frequency drives, main disconnects, breakers, generators, or power supply,
- Field wiring, interconnecting wiring, conduit, wiring terminations at equipment, local equipment disconnects, local equipment control panels, and wiring terminations at control panels,
- All electrical and mechanical hardware with the exception of the equipment that is identified above,
- All work associated with buildings or other structures used for housing any part of the system provided, including HVAC and electrical work.

## Schedule

- Shop drawings will be submitted within 6-8 weeks of receipt of an executed contract by all parties.
- All equipment will be delivered within 18-20 weeks after receipt of written approval of the shop drawings.
- Installation manuals will be furnished upon delivery of equipment.
- Operation and Maintenance Manuals will be submitted within 90 days after receipt of approved shop drawings.





## Pricing

The price for the BIOSTYR® systems, as defined herein, including process and design engineering, field services, and equipment supply is

<b>Option 2A(DN Biostyr):</b>	<b>\$18,000,000</b>
<b>Option 4C (DN Biostyr):</b>	<b>\$30,000,000</b>
<b>Option 4C R1 (DN Biostyr):</b>	<b>\$30,000,000</b>
<b>Option 4D (N+DN Biostyr):</b>	<b>\$90,000,000</b>
<b>Option 4E (N/DN+DN Biostyr):</b>	<b>\$130,000,000</b>

**Please note that the above pricing is expressly contingent upon the items in this proposal and are subject to Kruger Standard Terms of Sale detailed herein.**

This pricing is FOB shipping point, with freight allowed to the job site. This pricing does not include any sales or use taxes. In addition, pricing is valid for ninety (90) days from the date of issue and is subject to negotiation of a mutually acceptable contract.

### Terms of Payment

The terms of payment are as follows:

- 10% on receipt of fully executed contract
- 15% on submittal of shop drawings
- 75% on the delivery of equipment to the site

Payment shall not be contingent upon receipt of funds by the Contractor from the Owner. There shall be no retention in payments due to Kruger. All other terms per our Standard Terms of Sale are attached.

All payment terms are net 30 days from the date of invoice. Final payment not to exceed 120 days from delivery of equipment.



## Kruger Standard Terms of Sale

1. Applicable Terms. These terms govern the purchase and sale of the equipment and related services, if any (collectively, "Equipment"), referred to in Seller's purchase order, quotation, proposal or acknowledgment, as the case may be ("Seller's Documentation"). Whether these terms are included in an offer or an acceptance by Seller, such offer or acceptance is conditioned on Buyer's assent to these terms. Seller rejects all additional or different terms in any of Buyer's forms or documents.
2. Payment. Buyer shall pay Seller the full purchase price as set forth in Seller's Documentation. Unless Seller's Documentation provides otherwise, freight, storage, insurance and all taxes, duties or other governmental charges relating to the Equipment shall be paid by Buyer. If Seller is required to pay any such charges, Buyer shall immediately reimburse Seller. All payments are due within 30 days after receipt of invoice. Buyer shall be charged the lower of 1 ½% interest per month or the maximum legal rate on all amounts not received by the due date and shall pay all of Seller's reasonable costs (including attorneys' fees) of collecting amounts due but unpaid. All orders are subject to credit approval.
3. Delivery. Delivery of the Equipment shall be in material compliance with the schedule in Seller's Documentation. Unless Seller's Documentation provides otherwise, Delivery terms are F.O.B. Seller's facility.
4. Ownership of Materials. All devices, designs (including drawings, plans and specifications), estimates, prices, notes, electronic data and other documents or information prepared or disclosed by Seller, and all related intellectual property rights, shall remain Seller's property. Seller grants Buyer a non-exclusive, non-transferable license to use any such material solely for Buyer's use of the Equipment. Buyer shall not disclose any such material to third parties without Seller's prior written consent.
5. Changes. Seller shall not implement any changes in the scope of work described in Seller's Documentation unless Buyer and Seller agree in writing to the details of the change and any resulting price, schedule or other contractual modifications. This includes any changes necessitated by a change in applicable law occurring after the effective date of any contract including these terms.
6. Warranty. Subject to the following sentence, Seller warrants to Buyer that the Equipment shall materially conform to the description in Seller's Documentation and shall be free from defects in material and workmanship. The foregoing warranty shall not apply to any Equipment that is specified or otherwise demanded by Buyer and is not manufactured or selected by Seller, as to which (i) Seller hereby assigns to Buyer, to the extent assignable, any warranties made to Seller and (ii) Seller shall have no other liability to Buyer under warranty, tort or any other legal theory. If Buyer gives Seller prompt written notice of breach of this warranty within 18 months from delivery or 1 year from beneficial use, whichever occurs first (the "Warranty Period"), Seller shall, at its sole option and as Buyer's sole remedy, repair or replace the subject parts or refund the purchase price therefore. If Seller determines that any claimed breach is not, in fact, covered by this warranty, Buyer shall pay Seller its then customary charges for any repair or replacement made by Seller. Seller's warranty is conditioned on Buyer's (a) operating and maintaining the Equipment in accordance with Seller's instructions, (b) not making any unauthorized repairs or alterations, and (c) not being in default of any payment obligation to Seller. Seller's warranty does not cover damage caused by chemical action or abrasive material, misuse or improper installation (unless installed by Seller). THE WARRANTIES SET FORTH IN THIS SECTION ARE SELLER'S SOLE AND EXCLUSIVE WARRANTIES AND ARE SUBJECT TO SECTION 10 BELOW. SELLER MAKES NO OTHER WARRANTIES OF ANY KIND, EXPRESS OR IMPLIED, INCLUDING WITHOUT LIMITATION, ANY WARRANTY OF MERCHANTABILITY OR FITNESS FOR PURPOSE.
7. Indemnity. Seller shall indemnify, defend and hold Buyer harmless from any claim, cause of action or liability incurred by Buyer as a result of third party claims for personal injury, death or damage to tangible property, to the extent caused by Seller's negligence. Seller shall have the sole authority to direct the defense of and settle any indemnified claim. Seller's indemnification is conditioned on Buyer (a) promptly, within the Warranty Period, notifying Seller of any claim, and (b) providing reasonable cooperation in the defense of any claim.
8. Force Majeure. Neither Seller nor Buyer shall have any liability for any breach (except for breach of payment obligations) caused by extreme weather or other act of God, strike or other labor shortage or disturbance, fire, accident, war or civil disturbance, delay of carriers, failure of normal sources of supply, act of government or any other cause beyond such party's reasonable control.
9. Cancellation. If Buyer cancels or suspends its order for any reason other than Seller's breach, Buyer shall promptly pay Seller for work performed prior to cancellation or suspension and any other direct costs incurred by Seller as a result of such cancellation or suspension.
10. LIMITATION OF LIABILITY. NOTWITHSTANDING ANYTHING ELSE TO THE CONTRARY, SELLER SHALL NOT BE LIABLE FOR ANY CONSEQUENTIAL, INCIDENTAL, SPECIAL, PUNITIVE OR OTHER INDIRECT DAMAGES, AND SELLER'S TOTAL LIABILITY ARISING AT ANY TIME FROM THE SALE OR USE OF THE EQUIPMENT SHALL NOT EXCEED THE PURCHASE PRICE PAID FOR THE EQUIPMENT. THESE LIMITATIONS APPLY WHETHER THE LIABILITY IS BASED ON CONTRACT, TORT, STRICT LIABILITY OR ANY OTHER THEORY.
11. Miscellaneous. If these terms are issued in connection with a government contract, they shall be deemed to include those federal acquisition regulations that are required by law to be included. These terms, together with any quotation, purchase order or acknowledgement issued or signed by the Seller, comprise the complete and exclusive statement of the agreement between the parties (the "Agreement") and supersede any terms contained in Buyer's documents, unless separately signed by Seller. No part of the Agreement may be changed or cancelled except by a written document signed by Seller and Buyer. No course of dealing or performance, usage of trade or failure to enforce any term shall be used to modify the Agreement. If any of these terms is unenforceable, such term shall be limited only to the extent necessary to make it enforceable, and all other terms shall remain in full force and effect. Buyer may not assign or permit any other transfer of the Agreement without Seller's prior written consent. The Agreement shall be governed by the laws of the State of North Carolina without regard to its conflict of laws provisions.





**Example Layout – DN Stage Only**  
**King County, WA South Plant Rough Layout**

Date: 09/04/19

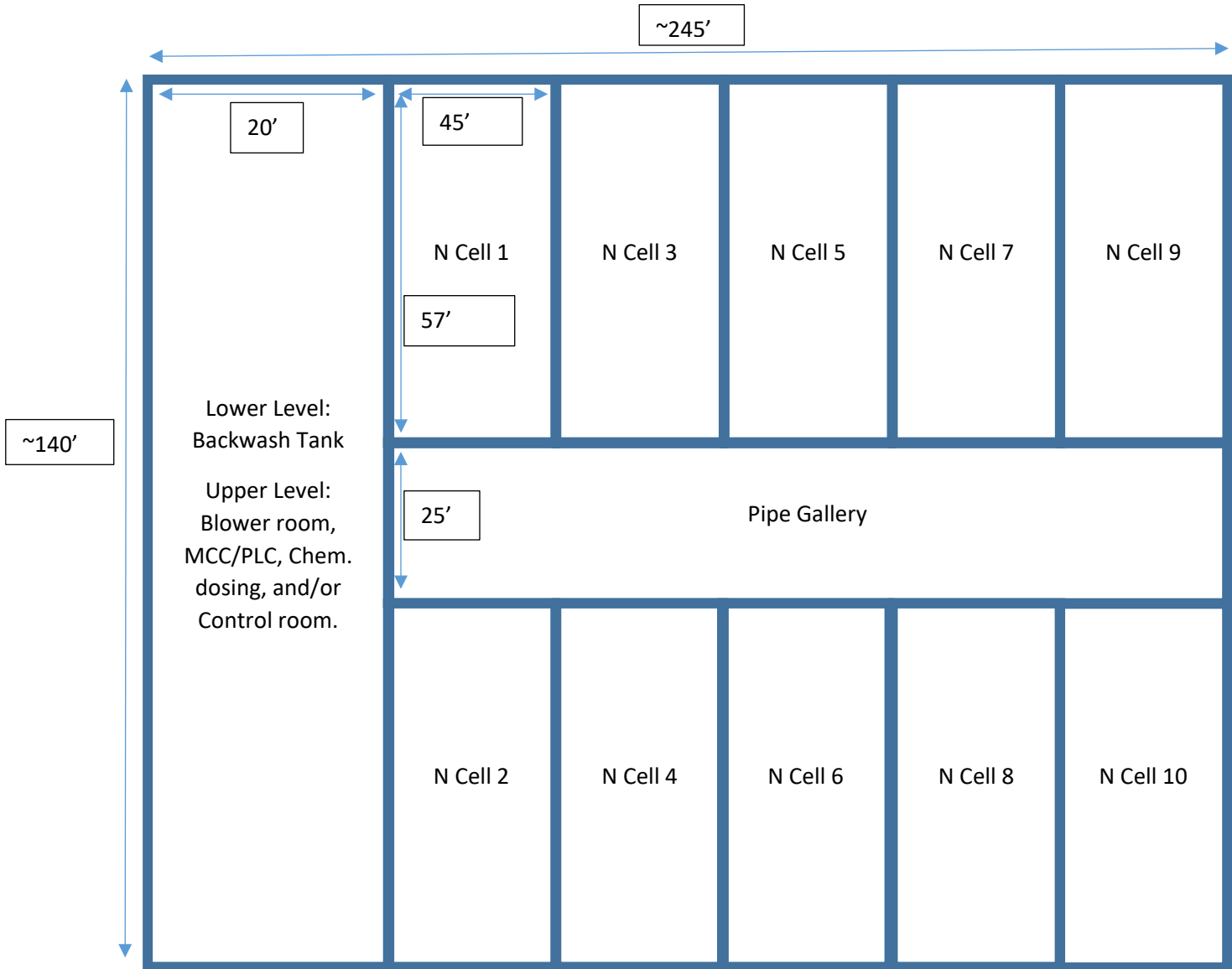

Item number	: 005	Size	: 57H-BRZ
Service	:	Stages	: 1
Quantity	: 1	Based on curve number	: 57_TURB_3880_0600_BR Rev 180719
Quote number	: 208516	Date last saved	: 28 Oct 2019 8:06 AM

**Operating Conditions**

Flow, rated	: 45.00 MG/day
Differential head / pressure, rated (requested)	: 50.00 ft
Differential head / pressure, rated (actual)	: 50.04 ft
Suction pressure, rated / max	: 0.00 / 0.00 psi.g
NPSH available, rated	: Ample
Frequency	: 60 Hz

**Performance**

Speed, rated	: 445 rpm
Impeller diameter, rated	: 37.72 in
Impeller diameter, maximum	: 40.00 in
Impeller diameter, minimum	: 34.00 in
Efficiency (bowl / pump)	: 88.51 / - %
NPSH required / margin required	: 15.76 / 0.00 ft
nq (imp. eye flow) / S (imp. eye flow)	: 77 / 186 Metric units
Minimum Continuous Stable Flow	: 34.54 MG/day
Head, maximum, rated diameter	: 87.59 ft
Head rise to shutoff (bowl / pump)	: 75.16 / - %
Flow, best eff. point (bowl / pump)	: 45.35 / - MG/day
Flow ratio, rated / BEP (bowl / pump)	: 99.22 / - %
Diameter ratio (rated / max)	: 94.30 %
Head ratio (rated dia / max dia)	: 83.41 %
Cq/Ch/Ce/Cn [ANSI/HI 9.6.7-2010]	: 1.00 / 1.00 / 1.00 / 1.00
Selection status	: Acceptable

**Liquid**

Liquid type	: Water
Additional liquid description	:
Solids diameter, max	: 0.00 in
Solids diameter limit	: 3.20 in
Solids concentration, by volume	: 0.00 %
Temperature, max	: 68.00 deg F
Fluid density, rated / max	: 1.000 / 1.000 SG
Viscosity, rated	: 1.00 cP
Vapor pressure, rated	: 0.34 psi.a

**Material**

Material selected	: Cast Iron bowl Std impeller
-------------------	-------------------------------

**Pressure Data**

Maximum working pressure	: See the Additional Data page
Maximum allowable working pressure	: See the Additional Data page
Maximum allowable suction pressure	: N/A
Hydrostatic test pressure	: See the Additional Data page

**Driver & Power Data (@Max density)**

Driver sizing specification	: Maximum power
Margin over specification	: 0.00 %
Service factor	: 1.00
Power, hydraulic	: 395 hp
Power (bowl / pump)	: 446 / - hp
Power, maximum, rated diameter	: 474 hp
Minimum recommended motor rating	: 500 hp / 373 kW

Bowl performance. Adjusted for construction and viscosity.  
The duty point represents the head at the bowl.

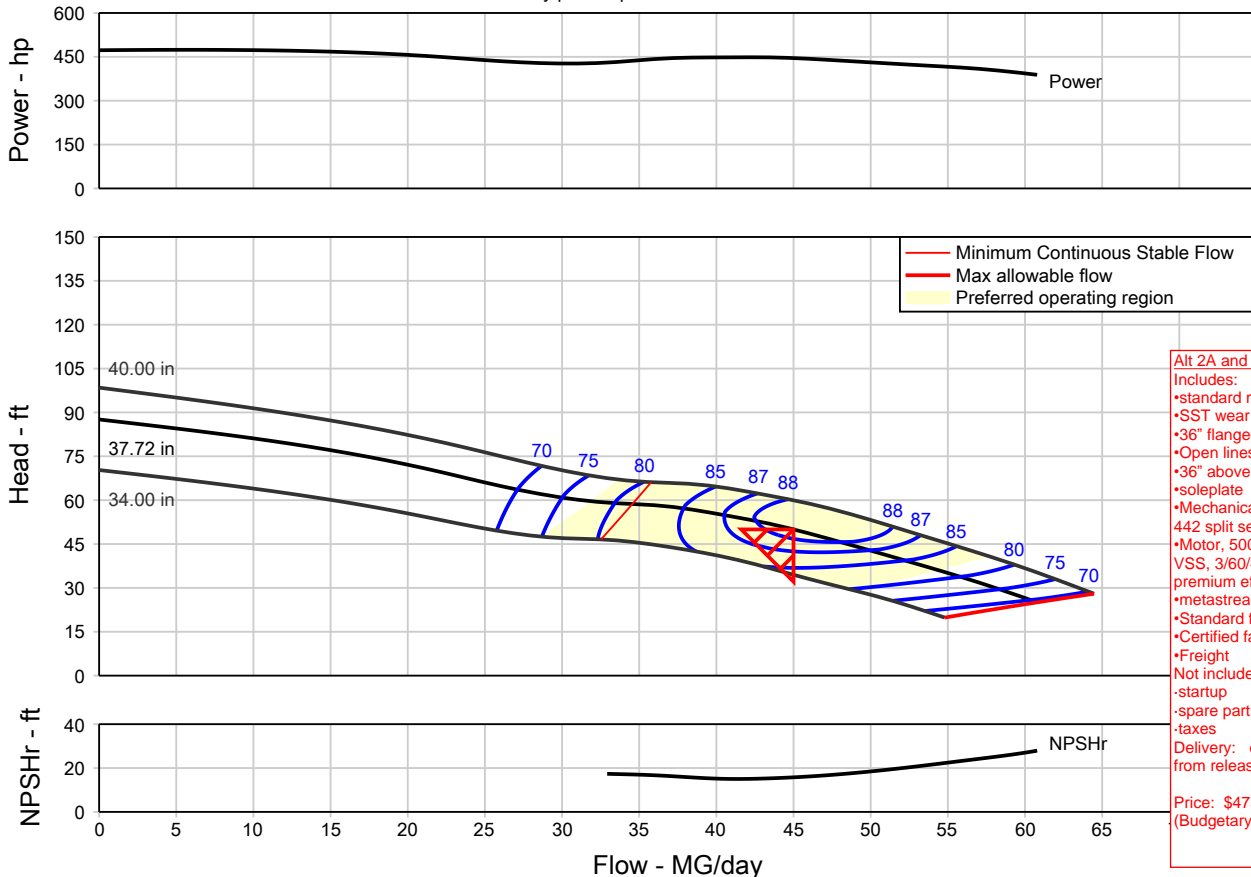

**Alt 2A and 4C**  
Includes:  
 •standard materials of construction  
 •SST wear rings  
 •36" flanged column  
 •Open lineshaft  
 •36" above ground discharge head  
 •soleplate  
 •Mechanical stuffing box w/ Chest  
 442 split seal  
 •Motor, 500HP, 450RPM, WP11, VSS, 3/60/460, inverter duty, premium eff  
 •metastream spacer coupling  
 •Standard factory coatings  
 •Certified factory testing  
 •Freight  
 Not included:  
 -startup  
 -spare parts  
 -taxes  
 Delivery: estimated 34 weeks from release to mfg  
 Price: \$475,000.00 Net Each (Budgetary estimate)

Item number	: 005	Size	: 57H-BRZ
Service	:	Stages	: 1
Quantity	: 1	Based on curve number	: 57_TURB_3880_0600_BR Rev 180719
Quote number	: 208516	Date last saved	: 28 Oct 2019 8:08 AM

**Operating Conditions**

Flow, rated	: 50.00 MG/day
Differential head / pressure, rated (requested)	: 50.00 ft
Differential head / pressure, rated (actual)	: 50.01 ft
Suction pressure, rated / max	: 0.00 / 0.00 psi.g
NPSH available, rated	: Ample
Frequency	: 60 Hz

**Performance**

Speed, rated	: 445 rpm
Impeller diameter, rated	: 39.32 in
Impeller diameter, maximum	: 40.00 in
Impeller diameter, minimum	: 34.00 in
Efficiency (bowl / pump)	: 88.37 / - %
NPSH required / margin required	: 18.45 / 0.00 ft
nq (imp. eye flow) / S (imp. eye flow)	: 77 / 186 Metric units
Minimum Continuous Stable Flow	: 35.41 MG/day
Head, maximum, rated diameter	: 95.29 ft
Head rise to shutoff (bowl / pump)	: 90.54 / - %
Flow, best eff. point (bowl / pump)	: 47.29 / - MG/day
Flow ratio, rated / BEP (bowl / pump)	: 105.74 / - %
Diameter ratio (rated / max)	: 98.30 %
Head ratio (rated dia / max dia)	: 93.94 %
Cq/Ch/Ce/Cn [ANSI/HI 9.6.7-2010]	: 1.00 / 1.00 / 1.00 / 1.00
Selection status	: Acceptable

**Liquid**

Liquid type	: Water
Additional liquid description	:
Solids diameter, max	: 0.00 in
Solids diameter limit	: 3.20 in
Solids concentration, by volume	: 0.00 %
Temperature, max	: 68.00 deg F
Fluid density, rated / max	: 1.000 / 1.000 SG
Viscosity, rated	: 1.00 cP
Vapor pressure, rated	: 0.34 psi.a

**Material**

Material selected	: Cast Iron bowl Std impeller
-------------------	-------------------------------

**Pressure Data**

Maximum working pressure	: See the Additional Data page
Maximum allowable working pressure	: See the Additional Data page
Maximum allowable suction pressure	: N/A
Hydrostatic test pressure	: See the Additional Data page

**Driver & Power Data (@Max density)**

Driver sizing specification	: Maximum power
Margin over specification	: 0.00 %
Service factor	: 1.00
Power, hydraulic	: 438 hp
Power (bowl / pump)	: 496 / - hp
Power, maximum, rated diameter	: 536 hp
Minimum recommended motor rating	: 600 hp / 447 kW

Bowl performance. Adjusted for construction and viscosity.  
The duty point represents the head at the bowl.

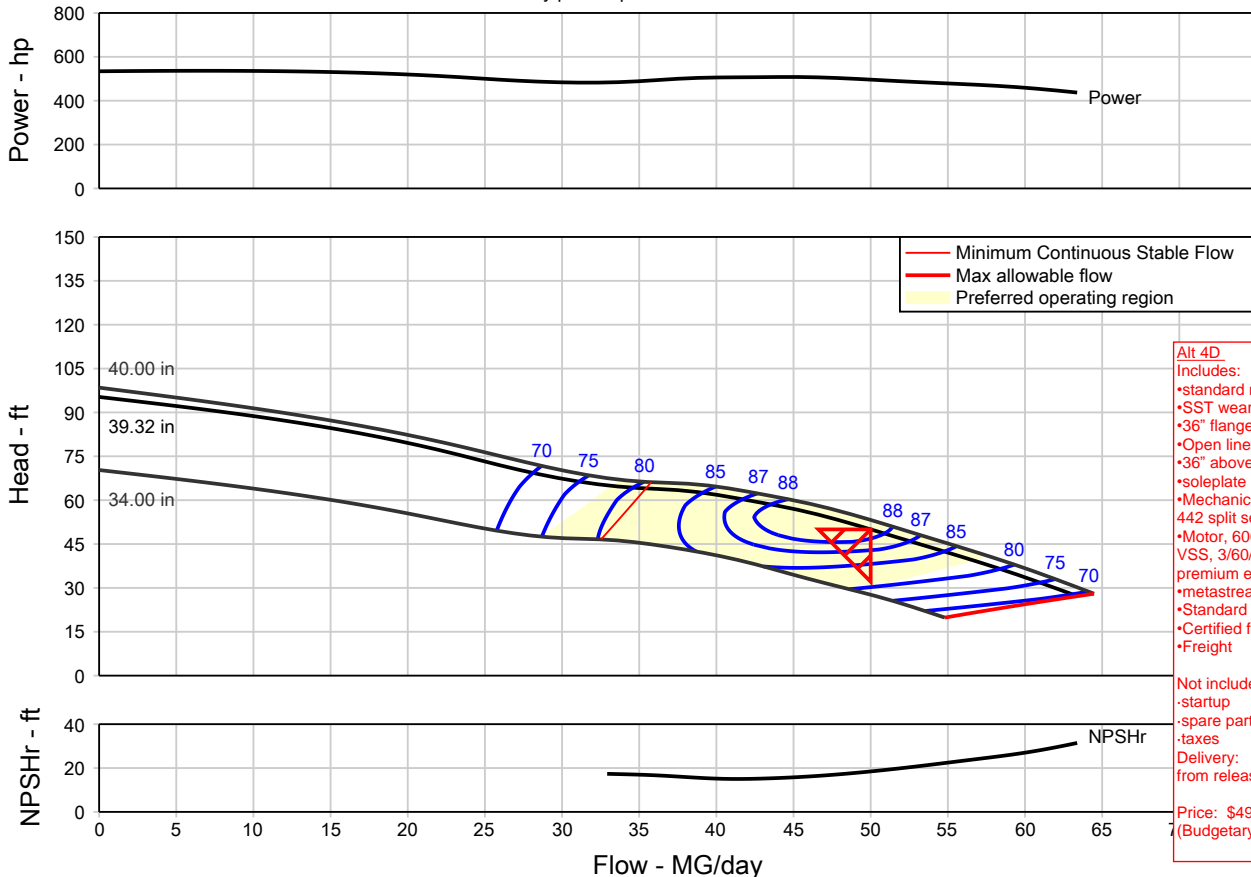

- Alt 4D**  
Includes:
- standard materials of construction
  - SST wear rings
  - 36" flanged column
  - Open lineshaft
  - 36" above ground discharge head
  - soleplate
  - Mechanical stuffing box w/ Chest 442 split seal
  - Motor, 600HP, 450RPM, WP11, VSS, 3/60/460, inverter duty, premium eff
  - metastream spacer coupling
  - Standard factory coatings
  - Certified factory testing
  - Freight

- Not included:
- startup
  - spare parts
  - taxes
- Delivery: estimated 34 weeks from release to mfg

Price: \$495,000.00 Net Each (Budgetary estimate)

# ⚠ WARNING

DO NOT OPERATE THIS MACHINE WITHOUT PROTECTIVE GUARD IN PLACE. ANY OPERATION OF THIS MACHINE WITHOUT PROTECTIVE GUARD CAN RESULT IN SEVERE BODILY INJURY.

## DISCHARGE HEAD DIMENSIONS

DISCH SIZE	COL SIZE	MOTOR BD	A**	A1	B	C	E	F	F1	G	H	K	L
36	36	TBD	80.5	TBD	43	45	40	2	2	72	1.13	34	2

\*\*ADD 4 1/2" FOR VSS DRIVER AND SPACER COUPLING

V	X	Z	AX	M
79.50	29	100	58	62

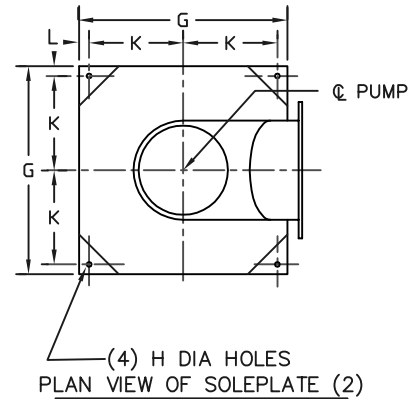
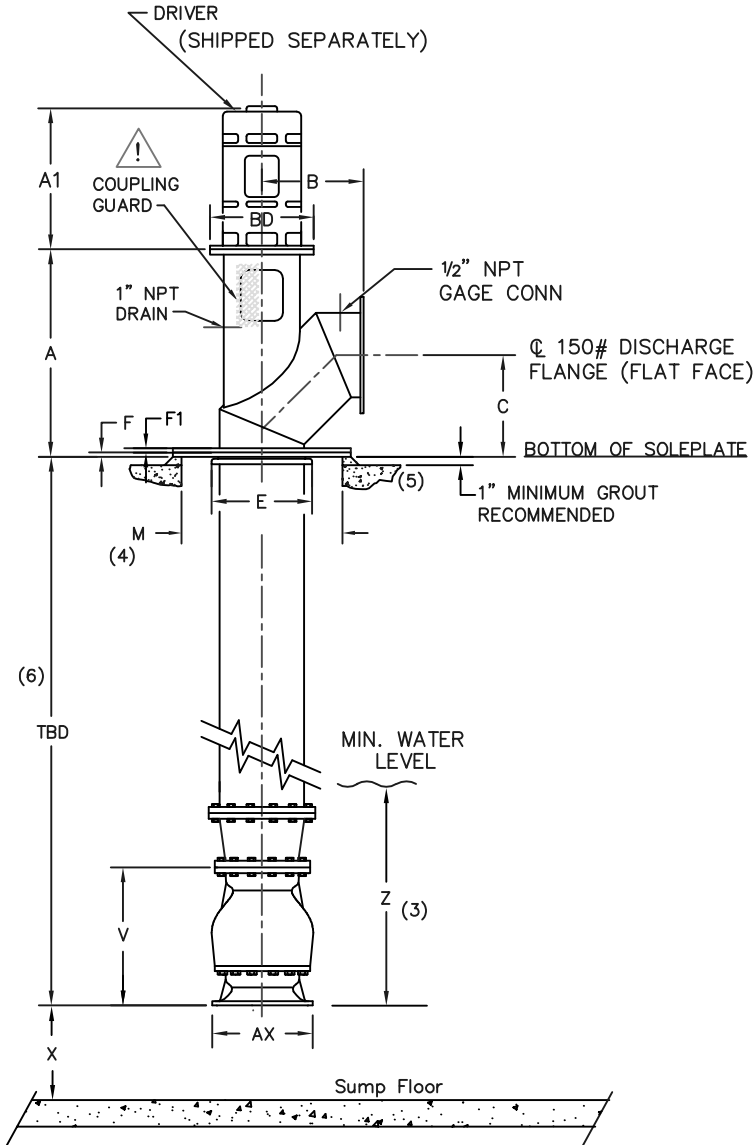

1. THIS DRAWING NOT FOR CONSTRUCTION OR INSTALLATION UNLESS CERTIFIED. DIMENSIONS SHOWN ARE TYPICAL AND MAY VARY DUE TO VARIOUS TOLERANCES.
2. SOLEPLATE MUST BE SUPPORTED ON ALL 4 SIDES AND GROUTED IN PLACE.
3. MINIMUM SUBMERGENCE REQUIRED AT MAXIMUM FLOW, TO BE DETERMINED.

4. MINIMUM DIAMETER REQUIRED TO REMOVE BOWL ASSEMBLY
5. DETAIL SHOWN FOR ILLUSTRATION ONLY AND IS NOT INTENDED TO REPRESENT THE ACTUAL INSTALLATION.
6. CUSTOMER TO VERIFY OR ADVISE OVERALL LENGTH PRIOR TO OR AT RELEASE.

CUSTOMER					P.O.				
JOB NAME				SERVICE					
PUMP SIZE & MODEL 57H		STAGES 1	GPM	TDH	NOM. RPM 445	ROT CCW			
MOTOR	HP	FRAME	PHASE	HERTZ	VOLTS	ENCL	SETTING PLAN 57H 7000-AW (1 STAGE) TYPE "F" SURFACE HEAD WITH SOLEPLATE FLANGED DISCHARGE		
DRAWN FOR		DRAWN BY			DATE				

## Appendix G: TM 3C—Brightwater

---



This page intentionally left blank.



# Technical Memorandum

701 Pike Street, Suite 1200  
Seattle, WA 98101-2310

Phone: 206-624-0100  
Fax: 206-749-2200

Prepared for: King County

Project Title: King County Flows and Loads—Nitrogen Removal Study

Project No.: 151084.464

## Technical Memorandum 3C

Subject: Brightwater Site-Specific Nitrogen Removal Analysis of Planning Alternatives

Date: September 9, 2020

To: Eron Jacobson, King County Nitrogen Removal Task Lead

From: Rick Kelly, Brown and Caldwell Nitrogen Removal Task Lead

Prepared by: \_\_\_\_\_  
Patricia Tam, P.E., WA License. No. 35722, Expiration 9/10/2021

\_\_\_\_\_  
Matt Winkler, P.E., WA License. No. 52196, Expiration 3/4/2021

Reviewed by: \_\_\_\_\_  
Richard Kelly, Ph.D., P.E., WA License. No. 45235, Expiration 6/3/2021

*This document was prepared solely for King County in accordance with professional standards at the time the services were performed and in accordance with the contract between King County and Brown and Caldwell dated August 1, 2017. This document is governed by the specific scope of work authorized by King County; it is not intended to be relied upon by any other party except for regulatory authorities contemplated by the scope of work. We have relied on information or instructions provided by King County and other parties and, unless otherwise expressly indicated, have made no independent investigation as to the validity, completeness, or accuracy of such information.*

# Table of Contents

Section 1: Introduction .....	1
Section 2: Basis of Analysis and Assumptions .....	1
Section 3: Discussion of Alternatives .....	4
3.1 Base Case – SND Only.....	5
3.2 Scenario 1 – SND With Sidestream Treatment .....	6
3.2.1 Alternative 1 – SND/MBR + Sidestream Anammox .....	6
3.3 Scenario 2 – Year-round Nitrogen Removal with Effluent TIN Limit of 8 mg/L Equivalent.....	8
3.3.1 Alternative 2A – SND/MBR + Sidestream Anammox .....	8
3.3.2 Alternative 2B – MLE/MBR + Sidestream Anammox .....	10
3.3.3 Alternative 2C – MLE/MBR + Tertiary Denitrifying Fixed-Film + Sidestream Anammox .....	12
3.4 Scenario 3 – Year-round Nitrogen Removal with Effluent TIN Limit of 3 mg/L.....	14
3.4.1 Alternative 3A – SND/MBR + Sidestream Anammox.....	14
3.4.2 Alternative 3B – 4SMB/MBR + Sidestream Anammox.....	16
3.4.3 Alternative 3C – MLE/MBR + Tertiary Denitrifying Fixed-Film + Sidestream Anammox .....	18
Section 4: Cost Analysis.....	19
4.1 Capital Costs .....	19
4.1.1 Site-Specific Capital Cost Assumptions.....	20
4.1.2 Summary of Capital Costs.....	20
4.2 O&M Costs.....	22
4.2.1 Site-Specific O&M Cost Assumptions .....	22
4.2.2 Summary of O&M Costs .....	22
4.3 Life-Cycle Costs .....	23
Section 5: Comparison and Ranking of Alternatives.....	24
5.1 Evaluation Criteria and Weighting .....	24
5.1.1 Technology Status .....	24
5.1.2 Effluent Nitrogen Load Reduction .....	24
5.1.3 Load Variation Impact .....	24
5.1.4 Flow Variation Impact.....	24
5.1.5 Space for Future Expansion.....	24
5.1.5 Impacts to Other Processes.....	25
5.1.6 GHG Emissions .....	25
5.1.7 CEC and Toxics Removal Potential.....	25
5.1.10 Capital Cost.....	25
5.1.11 O&M Cost.....	25
5.1.12 Supplementary Carbon Source Flexibility .....	25
5.1.13 Risks.....	26
5.1.14 Constructability.....	26



5.1.15 Operational Complexity .....26

5.2 Evaluation Results .....27

Section 6: Summary .....30

Attachment A: Site Layouts .....A-1

Attachment B: Greenhouse Gas Emissions Results and Literature Review of Nitrous Oxide Emission Factors .....B-1

Attachment C: Basis of Capital Cost Estimates of Alternatives.....C-1

Attachment D: Budgetary Proposals for Equipment .....D-1

## List of Figures

---

Figure 1. Process flow schematic for Alternative 1 – SND/MBR + sidestream anammox.....7

Figure 2. Process flow schematic for Alternative 2A – MLE/MBR + sidestream anammox .....9

Figure 3. Process flow schematic for Alternative 2B – MLE/MBR + sidestream anammox.....11

Figure 4. Process flow schematic for Alternative 2C – MLE/MBR + tertiary denitrifying fixed-film + sidestream anammox .....12

Figure 5. Process flow schematic for Alternative 3A – SND/MBR + sidestream anammox.....15

Figure 6. Process flow schematic for Alternative 3B – 4SMB/MBR + sidestream anammox .....16

Figure 7. Process flow schematic for Alternative 3C – MLE/MBR + tertiary denitrifying fixed-film + sidestream anammox .....18

Figure 8. Comparison of estimated GHG emissions .....27

Figure 9. Comparison of alternatives—scoring results.....29



## List of Tables

---

Table 1. Brightwater Design Flows and Loadings for Nitrogen Removal Analysis .....	2
Table 2. Summary of Selected Alternatives for Brightwater Nitrogen Removal Scenarios .....	5
Table 3. Brightwater Nitrogen Removal Modeling Results and System Sizing for Alternative 1.....	7
Table 4. Brightwater GHG Emissions for Alternative 1.....	8
Table 5. Brightwater Nitrogen Removal Modeling Results and System Sizing for Alternative 2A .....	9
Table 6. Brightwater GHG Emissions for Alternative 2A .....	10
Table 7. Brightwater Nitrogen Removal Modeling Results and System Sizing for Alternative 2B.....	11
Table 8. Brightwater GHG Emissions for Alternative 2B.....	12
Table 9. Brightwater Nitrogen Removal Modeling Results and System Sizing for Alternative 2C.....	13
Table 10. Brightwater GHG Emissions for Alternative 2C.....	14
Table 11. Brightwater Nitrogen Removal Modeling Results and System Sizing for Alternative 3A.....	15
Table 12. Brightwater GHG Emissions for Alternative 3A.....	16
Table 13. Brightwater Nitrogen Removal Modeling Results and System Sizing for Alternative 3B .....	17
Table 14. Brightwater GHG Emissions for Alternative 3B.....	17
Table 15. Brightwater Nitrogen Removal Modeling Results and System Sizing for Alternative 3C.....	18
Table 16. Brightwater GHG Emissions for Alternative 3C.....	19
Table 17. Summary of Capital Costs for Brightwater Alternatives .....	21
Table 18. Summary of Annual O&M Costs for Brightwater Alternatives .....	22
Table 19. Summary of Life-Cycle Costs for Brightwater Alternatives .....	23
Table 20. Comparison of Alternatives – Modeling and LCCA Results .....	28



## List of Abbreviations

---

°C	degrees Celsius	MG	million gallons
4SMB	4-Stage Modified Bardenpho	mg/L	milligrams per liter
BOD	biochemical oxygen demand	mgd	million gallons per day
Brightwater	Brightwater Treatment Plant	MLE	modified Ludzack-Ettinger
BWABO	Brightwater Aeration Basin Optimization	MT	metric tons
CEC	compounds of emerging concern	MT/yr	metric tons per year
CEPT	chemically enhanced primary treatment	N	nitrogen
CO <sub>2</sub>	carbon dioxide	NEB	net environmental benefit
CO <sub>2</sub> e	carbon dioxide equivalent	NPV	net present value
County	King County	O&M	operations and maintenance
DO	dissolved oxygen	RAS	return activated sludge
DT	dry tons	scfm	standard cubic feet per minute
FTE	full-time equivalent	SND	simultaneous nitrification/denitrification
gfd	gallons per square foot per day	SRT	solids retention time
GHG	greenhouse gas	TIN	total inorganic nitrogen
IMLR	internal mixed liquor recycle	TM	technical memorandum
kWH	kilowatt hour	TN	total nitrogen
lb/d	pounds per day	TSS	total suspended solids
LCCA	life-cycle cost analysis	WAS	waste activated sludge
MBR	membrane bioreactor	WTD	Wastewater Treatment Division



## Section 1: Introduction

This technical memorandum (TM) documents the evaluation of selected planning-level alternatives for nitrogen removal at the Brightwater Treatment Plant (Brightwater). This evaluation follows the initial technology screening analysis (documented in the *Nitrogen Removal Technologies Technical Summaries and Pre-Screening TM* [TM 1]), and the subsequent development of three nitrogen removal scenarios and selection of alternatives for further evaluation (documented in the *Brightwater Nitrogen Removal Technology Combinations Review and Screening TM* [TM 2]). Each selected alternative was modeled using the previously calibrated biological process simulator BioWin to provide sizing information for expanding existing treatment processes and/or adding new processes. Planning-level information was developed, including:

- Site layouts
- Capital costs
- Operating costs
- Life-cycle cost analyses (LCCA)
- Anticipated treatment performance and effluent quality related to nitrogen removal
- Estimated biosolids production
- Sustainability analysis results expressed as greenhouse gas (GHG) emissions

Seven alternatives were compared using a matrix of evaluation criteria that was adapted and updated from the previous alternatives screening process. The results were presented in the Brightwater Nitrogen Removal Workshop 2 with King County's (County) Wastewater Treatment Division (WTD) staff on February 10, 2020. This TM includes changes made to the analysis based on feedback and discussion from the workshop. The final results include a range of costs, GHG emissions, and other operational impacts for alternatives associated with each nitrogen removal scenario.

In general, the results of this evaluation are high-level in nature. A more detailed analysis would be needed to confirm or refine the process sizing and to re-evaluate alternatives selection during facility planning and subsequent design efforts.

## Section 2: Basis of Analysis and Assumptions

To develop the planning-level information for the analysis, the current rated design flows and loadings for Brightwater were assumed (Table 1). The current rated design flows and loadings were selected as the basis for this evaluation based on discussion with the County. The different nitrogen removal scenarios considered for this analysis include both year-round and seasonal limits. As a result, peaking factors were assumed and used to calculate the corresponding flows and loadings under different seasonal conditions.





Table 1. Brightwater Design Flows and Loadings for Nitrogen Removal Analysis		
Parameter	Value	Basis/Reference
<b>Design influent flows and loads</b>		
Annual average		
Flow, (mgd)	25.2	Design drawings for Brightwater Treatment Plant construction (2012) (2016 condition as shown on design drawings)
BOD, pounds per day (lb/d)	50,447	
TSS, lb/d	50,447	Estimated from BOD/TKN ratio from 2018 wastewater characterization
TKN, lb/d	9,500	
Maximum month		
Flow, mgd	40.9	Max month flows and loadings also correspond to current rated capacities as shown in NPDES permit effective March 1, 2018
BOD, lb/d	66,063	
TSS, lb/d	61,400	Estimated from BOD/TKN ratio from 2018 wastewater characterization
TKN, lb/d	12,500	
<b>Peaking Factors</b>		
Flow		
Max month/average dry weather	1.67	Calculated from projections provided by King County in TM "Brightwater Treatment Plant Peak Flow and Wasteload Projections 2010-2060" (January 2019)
Max month/average wet weather	1.36	
BOD		
Max month/average dry weather	1.23	
Max month/average wet weather	1.23	
TSS		
Max month/average dry weather	1.15	
Max month/average wet weather	1.15	
<b>Summer average flow and load</b>		
Flow, mgd	24.5	Average dry weather flow and loads
BOD, lb/d	53,714	Use for average summer-period performance and operating costs
TSS, lb/d	53,437	
TKN, lb/d	9,100	
<b>Winter average flow and load</b>		
Flow, mgd	30.0	Average wet weather flow and loads
BOD, lb/d	53,714	Use for average winter- and shoulder-period performance and operating costs
TSS, lb/d	53,437	
TKN, lb/d	9,900	
<b>Summer average flow and max month load</b>		
Flow, mgd	24.5	Average dry weather flow, max month load
BOD, lb/d	66,063	Use for checking summer max month load performance and capacity
TSS, lb/d	61,400	
TKN, lb/d	12,500	
<b>Winter max month flow and load</b>		
Flow, mgd	40.9	Max month flow, max month load
BOD, lb/d	66,063	Use for sizing worst-case nitrification at minimum winter temperature for year-round scenarios
TSS, lb/d	61,400	
TKN, lb/d	12,500	

BOD = biochemical oxygen demand

lb/d = pounds per day

mgd = million gallons per day

TSS = total suspended solids



Other assumptions used in modeling the different alternatives include:

- All modeling and sizing conducted for this study was based on the current rated flows and loads for Brightwater. This was decided to effectively represent the costs of performing nitrogen removal for existing conditions. Further evaluation would be needed to assess impacts of operation at actual and projected flows and loads, as would typically be done for King County basis of design on capital projects.
- To provide adequate treatment capacity for the current rated flows and loadings, additional infrastructure is required based on plant capacity analysis and the on-going Brightwater Aeration Basin Optimization (BWABO) Project (WTD capital project number 1129532). The BWABO project includes implementation of simultaneous nitrification/denitrification (SND). These plant improvements are considered as part of a base case for this analysis. Information on the additional infrastructure and assumptions for the base case is provided in Section 3.
- Mixed liquor temperatures, based on membrane permeate temperature data from January 2013 to December 2017, were assumed as follows:
  - Summer period: 20.5 degrees Celsius (°C) (average), 22.8°C (maximum)
  - Winter period: 16.1°C (average), 13.5°C (minimum)
- Secondary influent wastewater characteristics (except for biochemical oxidation demand [BOD] and total suspended solids (TSS) were based on model calibration for the March 2018 sampling data, adjusted for removal of centrate loads. Calculated ratios of 2.08 for chemical oxygen demand to BOD, and 7.94 for chemical oxygen demand to total Kjeldahl nitrogen, were used.
- Centrate characteristics are based on March 2018 centrate sampling data.
- At least one aeration basin and four membrane basins can be out of service during the summer period.
- For all alternatives, membrane basin sizing and membrane requirements were determined by assuming a peak flux rate of 10 gallons per square foot per day (gfd) under either winter or shoulder conditions. This peak flux rate is similar to the peak hour membrane capacity of 28 million gallons per day (mgd) under winter conditions for the existing membrane bioreactor (MBR) system at Brightwater based on peak flow test data from August 2013 to June 2015. A peak flux rate of 10 gfd is considerably lower than the typical design flux rate used by the membrane manufacturer. For example, Suez, which supplies the MBR equipment at Brightwater, recommends a peak design flux rate of 18.2 gfd at a design minimum temperature of 11°C. Budgetary proposals were obtained for the 10-gfd flux limit, and site layouts and cost estimating are also based on the 10-gfd flux limit. Budgetary proposals for equipment are included in Attachment D.
- For each alternative, the MBR system would receive flow up to its maximum capacity. When plant flow exceeds the MBR capacity, chemically enhanced primary treatment (CEPT) is triggered to treat the excess flow, and the MBR and CEPT effluent are combined as the final effluent. It was thus assumed in the analysis that there would be no flow transfers to the other plants when the MBR system capacity is exceeded.
- Site layouts developed from the modeling results for each alternative are preliminary and do not account for planned future capital projects unless otherwise specified on the site layouts. Any capital project for nitrogen removal will require further facility planning and alternatives analysis to evaluate other treatment plant needs and upgrades.

In addition to biological process modeling, a high-level GHG inventory was completed for each evaluated alternative. Details of the GHG analysis including references are provided in Attachment B. This GHG inventory was estimated based on the following methods and assumptions:

- The accounting of GHG emissions considered only operation emissions as a result of indirect and direct emissions. No GHG emissions were accounted for during construction (concrete, materials, machinery,



fuel consumption, etc.); however, it can be assumed that alternatives that require extensive amounts of concrete for construction are likely to have significantly higher purchasing-related emissions than alternatives that do not require extensive amounts of concrete.

- GHG emissions were estimated for the secondary, tertiary and sidestream treatment processes only, and do not include emissions from other facilities/processes in the plant.
- Accounting of emissions included direct nitrous oxide emissions from treatment and indirect nitrous oxide emissions from effluent nitrogen discharge, as well as carbon dioxide (CO<sub>2</sub>) emissions from transportation and materials usage and energy consumption.
- CO<sub>2</sub> emissions for energy use were based on the energy-source profile provided by the County for SnoPUD supplied electricity at Brightwater, with an emission factor of 0.0065 metric tons (MT) of CO<sub>2</sub> equivalent (CO<sub>2</sub>e) per megawatt-hour. It is worth noting that the GHG emissions for production of the electricity supplied to Brightwater are relatively low compared to most locations in the United States.
- Biogenic carbon dioxide emissions were not considered as part of the inventory as per the International Panel for Climate Change carbon accounting protocol and framework.
- *“Chapter 6 Nitrous Oxide Emissions from Domestic Wastewater”* was used as the primary method for estimating emissions. This method can be found in the *2019 Refinement to the 2006 Guidelines for National Greenhouse Gas Inventories*.
- Nitrous oxide emission factors were developed from a comprehensive literature review of different studies (Attachment B).
- Nitrous oxide may be removed partially across the odor control system for the aeration basins and membrane basins. For this analysis, it was assumed that the nitrous oxide emissions would remain unchanged across the odor control system. Assessment of potential removals should be conducted as part of any future planning effort for Brightwater.
- King County’s Strategic Climate Action Plan requires WTD to be carbon-neutral for its operations- and purchasing-related GHG emissions by 2025. The updated 2020 Strategic Climate Action Plan will likely require capital projects to purchase offsets for the County’s purchasing-related emissions. WTD’s current cost for purchasing offsets is \$10 per metric ton of carbon. The results of the GHG analysis are used for comparative purposes in this study, but it was not used to account for carbon offset costs in the LCCA due to the high-level nature of this analysis. A detailed GHG study should be completed as part of any future facility planning effort for Brightwater.

## Section 3: Discussion of Alternatives

As a result of Brightwater Nitrogen Removal Workshop 1 with County staff on June 10, 2019, three nitrogen removal scenarios and seven alternatives were initially selected for the site-specific analysis for Brightwater, as described in TM 2. The scenarios and alternatives evaluated in this analysis of planning alternatives are summarized in Table 2. A seasonal nitrogen removal scenario was not included because as an existing MBR facility, Brightwater is currently already providing year-round nitrification and enhancement of the denitrification capability has operational benefits.

Table 2. Summary of Selected Alternatives for Brightwater Nitrogen Removal Scenarios	
Alternative	Description
Scenario 1: SND with sidestream treatment (no specific effluent TIN limit)	
1	SND/MBR + sidestream anammox
Scenario 2: Year-round N removal, effluent 8 mg/L TIN equivalent	
2A	SND/MBR + sidestream anammox
2B	MLE/MBR + sidestream anammox
2C	MLE/MBR + tertiary denitrifying fixed-film + sidestream anammox
Scenario 3: Year-round N removal, effluent 3 mg/L TIN limit	
3A	SND/MBR + sidestream anammox
3B	4SMB/MBR + sidestream anammox
3C	MLE/MBR + tertiary denitrifying fixed-film + sidestream anammox

4SMB = 4-Stage Modified Bardenpho

mg/L = milligrams per liter

MLE = Modified Ludzack-Ettinger

N = nitrogen

TIN = total inorganic nitrogen

The following sections discuss each of the alternatives, including process description, modeling results, facility sizing, major equipment requirements, site layouts, and GHG emissions. Site layouts for each alternative consist of an aerial photograph of the plant marked up to show new or modified facilities and approximate flow paths for major piping. All site layouts are provided in Attachment A.

A plant hydraulic profile analysis was not conducted as part of this evaluation. It is recommended that a hydraulic analysis be conducted to confirm the hydraulic capability or to add hydraulic improvements as needed during facility planning and detailed design.

### 3.1 Base Case – SND Only

For this analysis, a base case condition was defined that includes the existing MBR secondary facility, expanded to treat the current rated flows and loadings. In addition, aeration control improvements required for transition to SND operation, along with construction of a new classifying selector for solids retention time (SRT) control and foam removal, will be implemented as part of the BWABO Project. The expanded facility including these improvements is the starting point for the analysis of planning alternatives for this study. In addition to the improvements implemented as part of the BWABO Project, the main capital improvements required for the base case include construction of one new aeration basin, installation of membrane cassettes in membrane basins 9 and 10, and construction of two new membrane basins (11 and 12). These new facilities are needed to meet the net environmental benefit requirements at the current rated flows and loadings.

Several operational changes will be made to implement SND. For this analysis, the following assumptions were made for the base case and all alternatives with SND as the mainstream process.

- DO zone control was assumed with low DO concentrations tapering across aerobic zones 1 through 3 (e.g., 0.4, 0.3, and 0.2 milligrams per liter [mg/L], respectively) and a high DO concentration in aerobic zone 4 (2 mg/L). In addition, the modeling was based on one set of SND kinetic parameters for ammonia-oxidizing bacteria (AOB), nitrite-oxidizing bacteria (NOB), and ordinary heterotrophic organisms. For actual SND implementation at Brightwater as part of the BWABO Project, DO concentrations will depend on the selected aeration control strategy for SND and kinetic parameters may vary from the

modeling conducted for this planning-level analysis. Both the aeration control strategy and kinetic parameters will impact the nitrogen removal performance with SND, and therefore will also impact requirements for supplemental carbon and alkalinity addition, as well as operational strategies for internal mixed liquor recycle (IMLR) pumping.

- For scenarios with effluent nitrogen limits (scenarios 2 and 3), the SND alternatives were modeled with increased IMLR pumping capacities and methanol addition to the anoxic zone and aerobic zone 3. It is likely that improvements to these strategies would be feasible with different aeration control strategies for SND. DO zone control with a lower DO concentration in aerobic zone 4, as well as ammonium-based aeration control or ammonium versus nitrate control are being investigated as part of the BWABO project. These aeration control strategies would likely improve overall nitrogen removal and could be used in conjunction with the supplemental carbon addition and changes to IMLR pumping investigated as part of this analysis.
- Actual SND performance at Brightwater will be demonstrated as part of the BWABO Project. SND operation is expected to start in 2023, following aeration control upgrades and implementation of improved SRT control with construction of a classifying selector.
- The SND modeling used for this analysis of planning alternatives provides a good basis of comparison to the other alternatives. However, observations and model calibration to actual SND performance will be valuable for any future nitrogen removal planning studies for Brightwater.

## 3.2 Scenario 1 – SND With Sidestream Treatment

This scenario minimizes capital improvements but also provides the least nitrogen removal relative to other options. Only one alternative is included for this scenario, as described below. The sidestream process was sized based on winter maximum month flow and loading conditions.

### 3.2.1 Alternative 1 – SND/MBR + Sidestream Anammox

This alternative expands upon the base case described above. The existing MBR secondary system is assumed to have been upgraded for SND as well as improved aeration control resulting from the ongoing BWABO Project. The SND operation would be optimized prior to any additional upgrade for increased nitrogen removal. To increase nitrogen removal beyond the base case while minimizing expansion of the MBR system, an anammox-based sidestream process would be added to reduce ammonia loading from the centrate that is routed to the secondary system by converting it to nitrogen gas. Figure 1 shows a process flow schematic for this alternative. An anammox-based process is assumed for this alternative because the only other feasible sidestream process, bioaugmentation, would offer minimal benefit for an MBR process, which would already be operating at a high SRT. To provide more benefit, the bioaugmentation process would need to be configured for nitrification/denitrification instead of nitrification alone, and would have higher operating costs and added complexity compared to an anammox system.

Table 3 summarizes the modeling results and sizing of major facilities and equipment for Alternative 1.

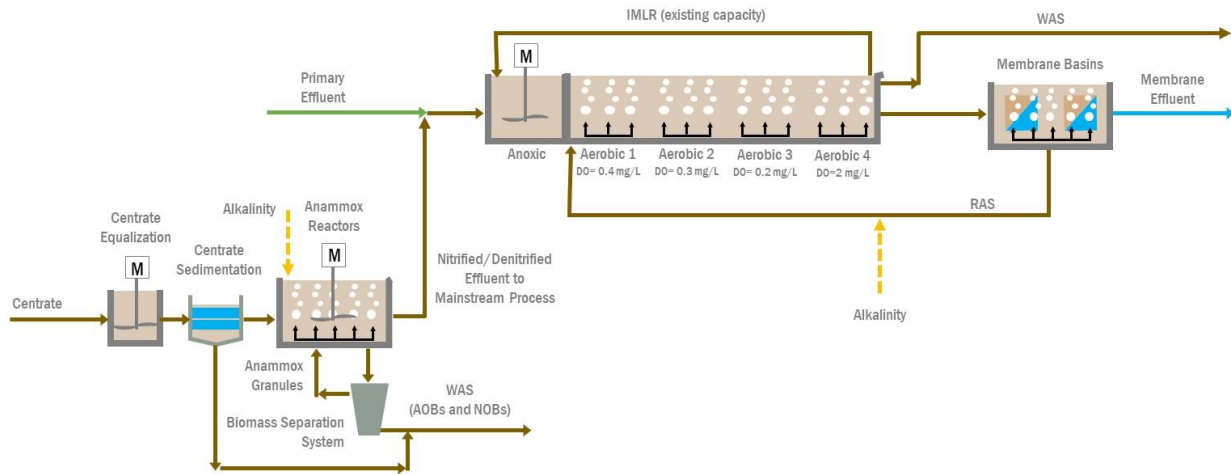

**Figure 1. Process flow schematic for Alternative 1 – SND/MBR + sidestream anammox**  
(WAS = waste activated sludge, RAS = return activated sludge)

Table 3. Brightwater Nitrogen Removal Modeling Results and System Sizing for Alternative 1	
Parameter	Value
Final effluent TIN, mg/L <sup>a</sup>	
@ winter max month flow and load	13
@ summer avg dry weather flow and load	11
@ winter avg wet weather flow and load	14
Overall TN removal, % <sup>a</sup>	
@ winter max month flow and load	58
@ summer avg dry weather flow and load	73
@ winter avg wet weather flow and load	62
Annual average	67
Annual average aeration requirements	
Aeration basin air flow, scfm	13,400
Membrane scouring air flow, scfm	30,000
Annual average supplemental chemical requirements	
Alkalinity (25% caustic), gpd	3,900
Methanol, gpd	0
New aeration basins	
Number of new basins	1
Volume per basin, MG	1.55
New membrane basins	
Peak hydraulic capacity (at 10-gfd flux limit)	42
Number of new basins <sup>b</sup>	2
Volume per basin, MG	0.12
Sidestream treatment	
Type	Anammox
Centrate equalization tank volume, gal	60,000
Number of reactor tanks	2
Volume of reactor tanks, gal	118,500

a. Final effluent concentrations and overall removals accounting for bypass of CEPT effluent around secondary treatment when flow exceeds peak MBR capacity.



b. Two new basins (membrane basins 11 and 12), in addition to installing membrane cassettes in basins 9 and 10.

*gpd = gallons per day*

*MG = million gallons*

*scfm = standard cubic feet per minute*

Table 1 includes the new aeration basin and new membrane basins, which are also included in the base case as discussed in Section 3.1. These new facilities are listed for this alternative (and other alternatives) because capital costs for these facilities are included in this analysis.

A preliminary site layout for Alternative 1 is provided in Attachment A. The new sidestream treatment facility is assumed to be located next to the headworks building.

**Challenges and Potential Risks.** The facility for this alternative can be constructed with relatively short implementation time and minimal impacts to the existing plant operations. This alternative, however, provides a relatively small increase in overall nitrogen removal compared with the base case condition, with average secondary effluent total inorganic nitrogen [TIN]) concentrations above 10 mg/L and an annual average total nitrogen (TN) removal of approximately 66 percent (as indicated by the results in Table 3). Plant performance for the base case condition is provided in Table 20.

Table 4 summarizes the estimated GHG emissions for Alternative 1.

Table 4. Brightwater GHG Emissions for Alternative 1	
Parameter	Value
GHG emissions carbon dioxide equivalent, metric tons per year (CO <sub>2</sub> e MT/yr)	
Nitrous oxide	29,200
Energy	130
Chemicals	4,200
Total	33,500

### 3.3 Scenario 2 – Year-round Nitrogen Removal with Effluent TIN Limit of 8 mg/L Equivalent

For this scenario, Brightwater would provide year-round nitrogen removal to achieve an equivalent effluent TIN limit of 8 mg/L. It is considered an equivalent limit, as the effluent TIN concentrations could be lower in the summer and higher in the winter, such that on an annual average basis the plant achieves an effluent TIN concentration no higher than 8 mg/L (calculated from the total annual average load and flow). Three alternatives were evaluated for this scenario, as described below. System sizing for these alternatives was based on winter maximum month flow and loading conditions.

For all Scenario 2 alternatives, a higher MBR capacity (and thus less bypass) would be needed to achieve the required overall nitrogen removal. As a result, four more membrane basins and a new primary effluent screen would be needed (compared to Alternative 1) to increase the MBR capacity. Aerated grit tank/primary clarifier train 6 was assumed to be added in conjunction with the new primary effluent screen. The existing odor control system for the secondary system would be expanded.

#### 3.3.1 Alternative 2A – SND/MBR + Sidestream Anammox

The general process configuration for this alternative is similar to that for Alternative 1. A higher degree of denitrification is required to meet the equivalent TIN limit of 8 mg/L. Figure 2 shows a process flow schematic for this alternative. As there is insufficient carbon available in the secondary influent, supplemental carbon, assumed here to be methanol, is required to improve denitrification in the MBR system.





Table 5 summarizes the modeling results and sizing of major facilities and equipment for Alternative 2A.

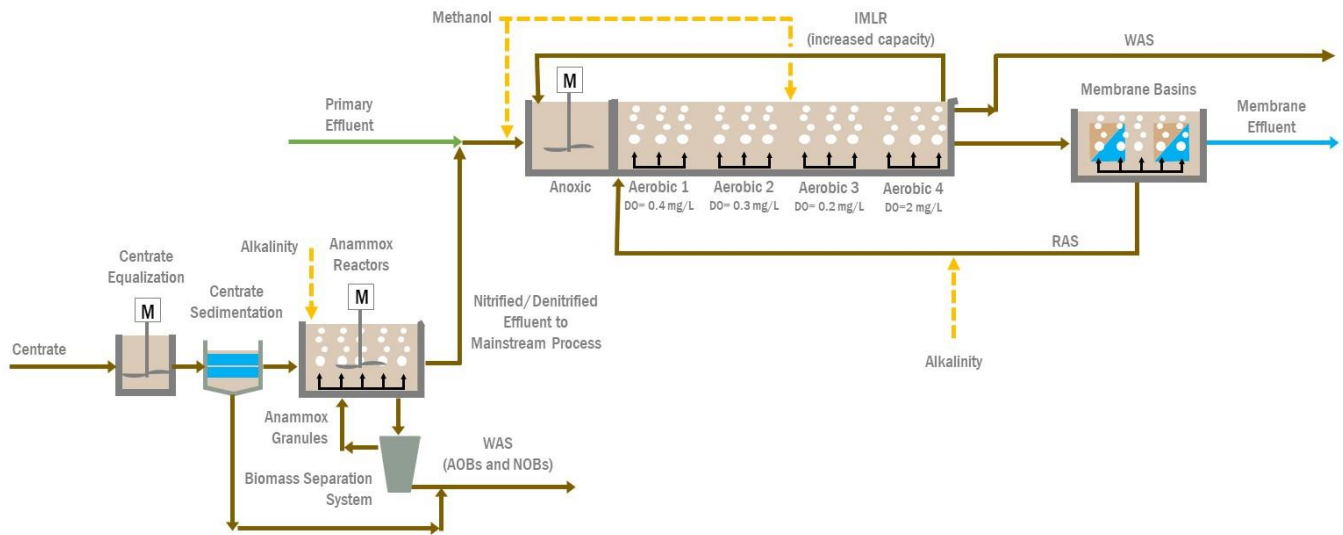

Figure 2. Process flow schematic for Alternative 2A – MLE/MBR + sidestream anammox

Table 5. Brightwater Nitrogen Removal Modeling Results and System Sizing for Alternative 2A	
Parameter	Value
Final effluent TIN, mg/L <sup>a</sup>	
@ winter max month flow and load	12
@ summer avg dry weather flow and load	3.0
@ winter avg wet weather flow and load	12
Overall TN removal, % <sup>a</sup>	
@ winter max month flow and load	63
@ summer avg dry weather flow and load	90
@ winter avg wet weather flow and load	66
Annual average	77
Annual average aeration requirements	
Aeration basin air flow, scfm	14,000
Membrane scouring air flow, scfm	36,000
Annual average supplemental chemical requirements	
Alkalinity (25% caustic), gpd	2,600
Methanol, gpd	1,210
New aeration basins	
Number of new basins	1
Volume per basin, MG	1.55
New membrane basins	
Peak hydraulic capacity (at 10-gfd flux limit)	56
Number of new basins <sup>b</sup>	6
Volume per basin, MG	0.12

Table 5. Brightwater Nitrogen Removal Modeling Results and System Sizing for Alternative 2A	
Parameter	Value
<b>Sidestream treatment</b>	
Type	Anammox
Centrate equalization tank volume, gal	60,000
Number of reactor tanks	2
Volume of reactor tanks, gal	118,500

- a. Final effluent concentrations and overall removals accounting for bypass of CEPT effluent around secondary treatment when flow exceeds peak MBR capacity.
- b. Six new basins (membrane basins 11–16), in addition to installing membrane cassettes in basins 9 and 10.

A preliminary site layout for Alternative 2A is provided in Attachment A. The facility for this alternative can be constructed with relatively minimal impacts to existing plant operations.

**Challenges and Potential Risks.** A potential risk for this alternative is the increased difficulty of achieving the effluent TIN target in a combined effluent (from MBR and CEPT) during winter peak flow conditions, as the CEPT effluent would have higher TIN concentrations than the MBR effluent. In addition, lower-than-expected membrane permeability during winter peak flow conditions would require additional MBR bypass (unless diversion to South Plant is feasible).

Table 6 summarizes the estimated GHG emissions for Alternative 2A.

Table 6. Brightwater GHG Emissions for Alternative 2A	
Parameter	Value
<b>GHG emissions (CO<sub>2</sub>e MT/yr)</b>	
Nitrous oxide	33,300
Energy	150
Chemicals	3,800
Total	37,200

### 3.3.2 Alternative 2B – MLE/MBR + Sidestream Anammox

In this alternative, instead of operating with SND, the aeration basins would be re-configured with optimally sized anoxic volume and IMLR pumping, with sidestream anammox and addition of supplemental carbon in the form of methanol to enhance denitrification. A swing zone, which would be equipped with both diffusers and mixers, would be added in each aeration basin, allowing the MBR system to operate with a higher fraction of anoxic volume as needed. Figure 3 shows a process flow schematic for Alternative 2B.

Table 7 summarizes the modeling results and sizing of major facilities and equipment for Alternative 2B.

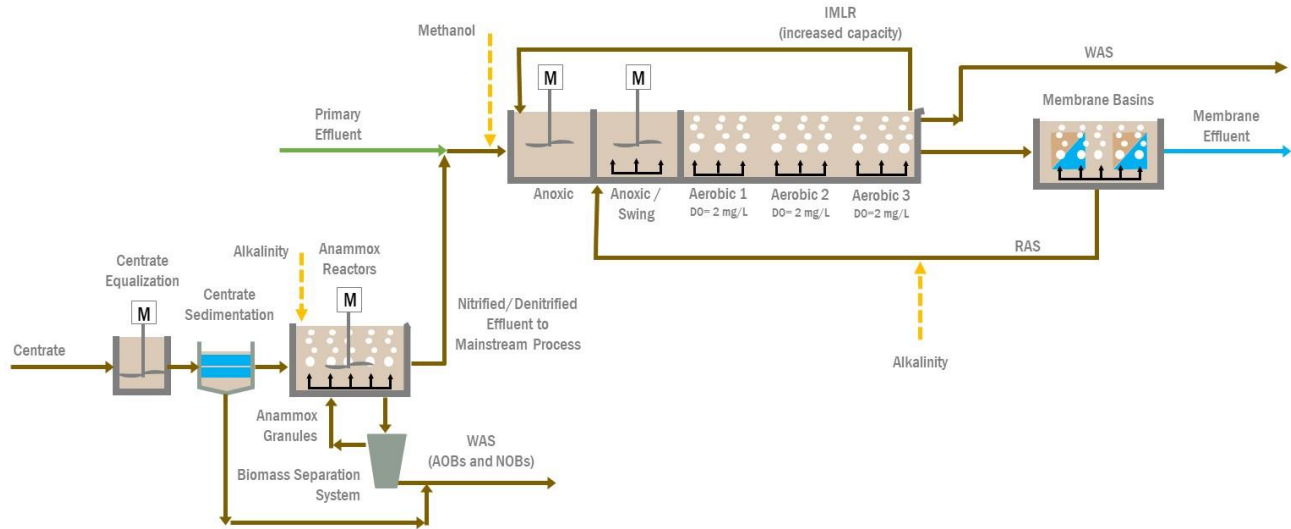

Figure 3. Process flow schematic for Alternative 2B – MLE/MBR + sidestream anammox.

Table 7. Brightwater Nitrogen Removal Modeling Results and System Sizing for Alternative 2B	
Parameter	Value
Final effluent TIN, mg/L <sup>a</sup>	
@ winter max month flow and load	8.8
@ summer avg dry weather flow and load	6.5
@ winter avg wet weather flow and load	8.9
Overall TN removal, % <sup>a</sup>	
@ winter max month flow and load	71
@ summer avg dry weather flow and load	82
@ winter avg wet weather flow and load	74
Annual average	78
Annual average aeration requirements	
Aeration basin air flow, scfm	15,350
Membrane scouring air flow, scfm	36,000
Annual average supplemental chemical requirements	
Alkalinity (25% caustic), gpd	2,600
Methanol, gpd	1,260
New aeration basins	
Number of new basins	1
Volume per basin, MG	1.55
New membrane basins	
Peak hydraulic capacity (at 10 gfd flux limit)	56
Number of new basins <sup>b</sup>	6
Volume per basin, MG	0.12
Sidestream treatment	
Type	Anammox
Centrate equalization tank volume, gal	60,000
Number of reactor tanks	2
Volume of reactor tanks, gal	118,500

- a. Final effluent concentrations and overall removals accounting for bypass of CEPT effluent around secondary treatment when flow exceeds peak MBR capacity.
- b. Six new basins (membrane basins 11–16), in addition to installing membrane cassettes in basins 9 and 10.

A preliminary site layout for Alternative 2B is provided in Attachment A. The layout for this alternative is the same as that for Alternative 2A. New aeration basin and membrane basin sizing also remains the same. This alternative has the same **challenges and potential risks** as Alternative 2A. Table 8 summarizes the estimated GHG emissions for Alternative 2B.

Table 8. Brightwater GHG Emissions for Alternative 2B	
Parameter	Value
GHG emissions (CO <sub>2</sub> e MT/yr)	
Nitrous oxide	2,400
Energy	150
Chemicals	3,800
Total	6,300

### 3.3.3 Alternative 2C – MLE/MBR + Tertiary Denitrifying Fixed-Film + Sidestream Anammox

This alternative is similar to Alternative 2B but with addition of a new tertiary denitrifying fixed-film system to provide additional effluent nitrogen removal. For this analysis, a denitrifying biologically active filter is assumed for the tertiary fixed-film system. The system would consist of filter cells with floating media, backwash tank and pumps, and associated controls and instrumentation. A tertiary feed pump station would be added to pump secondary effluent to the tertiary system. As there will be minimal carbon available in the secondary effluent, supplemental carbon in the form of methanol would be added to drive denitrification in the biologically active filter. Figure 4 shows a process flow schematic for this alternative. The tertiary system would receive flow from the MBR system only, so that any CEPT effluent that bypasses the MBR system under peak flow conditions would also bypass the tertiary system and would combine with the tertiary effluent prior to disinfection.

Table 9 summarizes the modeling results and sizing of major facilities and equipment for Alternative 2C.

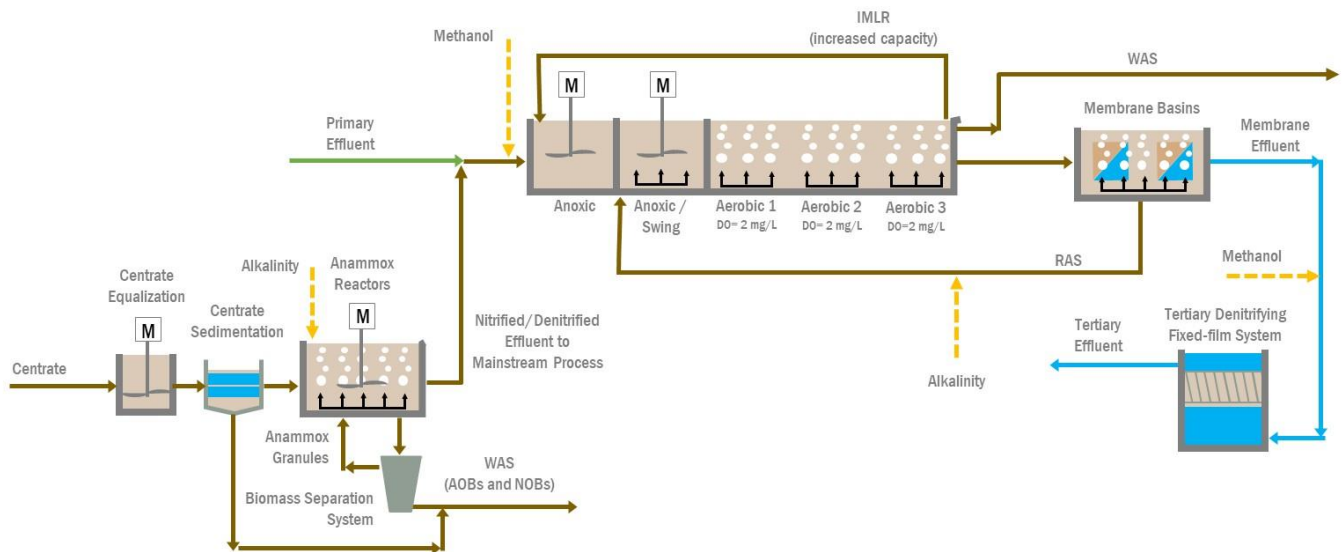

Figure 4. Process flow schematic for Alternative 2C – MLE/MBR + tertiary denitrifying fixed-film + sidestream anammox

**Table 9. Brightwater Nitrogen Removal Modeling Results and System Sizing for Alternative 2C**

Parameter	Value
Secondary effluent TIN, mg/L	
@ winter max month flow and load	17
@ summer avg dry weather flow and load	18
@ winter avg wet weather flow and load	18
Final effluent TIN, mg/L <sup>a,b</sup>	
@ winter max month flow and load	12
@ summer avg dry weather flow and load	3
@ winter avg wet weather flow and load	12
Overall TN removal, % <sup>b</sup>	
@ winter max month flow and load	60
@ summer avg dry weather flow and load	90
@ winter avg wet weather flow and load	66
Annual average	77
Annual average aeration requirements	
Aeration basin air flow, scfm	15,100
Membrane scouring air flow, scfm	36,000
Annual average supplemental chemical requirements	
Alkalinity (25% caustic), gpd	5,200
Methanol, gpd	1,110
New aeration basins	
Number of new basins	1
Volume per basin, MG	1.55
New membrane basins	
Peak hydraulic capacity (at 10-gfd flux limit)	56
Number of new basins <sup>c</sup>	6
Volume per basin, MG	0.12
Tertiary fixed-film system	
Number of denitrifying cells	6
Total cell volume, MG	0.51
Sidestream treatment	
Type	Anammox
Centrate equalization tank volume, gal	60,000
Number of reactor tanks	2
Volume of reactor tanks, gal	118,500

a. Final effluent concentrations to meet an equivalent final effluent TIN limit of 8 mg/L.

b. Final effluent concentrations and overall removals accounting for removals across tertiary process and for bypass of CEPT effluent around secondary treatment when flow exceeds peak MBR capacity.

c. Six new basins (membrane basins 11–16), in addition to installing membrane cassettes in basins 9 and 10.

A preliminary site layout for Alternative 2C is provided in Attachment A. The facilities for this alternative can likely be constructed with relatively minimal impacts to the existing plant operations, but the existing aeration basins would require more retrofits than for operation with SND. It was assumed that SND would have already been implemented as part of the BWABO project. The layout assumes that routing of large-diameter membrane effluent and tertiary effluent piping could fit in the area between the existing aeration and membrane basins.

**Challenges and Potential Risks.** The tertiary feed pump station and tertiary denitrifying fixed-film system are assumed to be located in the area east of the primary clarifiers. That would require extensive excavation of the east hillside and construction of a retaining wall, assumed in the layout to extend beyond the tertiary system along the full length of the aeration basins to provide space for the tertiary piping. The retaining wall was included in the capital cost estimates discussed in Section 4. Membrane effluent piping to the tertiary system would need to be routed outside of the area for the future aeration basins 5 and 6.

A potential risk for this alternative is the increased difficulty of achieving the effluent TIN target in a combined effluent (from tertiary system and CEPT) during winter peak flow conditions, as the CEPT effluent would have higher TIN concentrations than the tertiary effluent. In addition, lower-than-expected membrane permeability during winter peak flow condition would require additional MBR bypass (unless diversion to South Plant is feasible).

Table 10 summarizes the estimated GHG emissions for Alternative 2C.

Table 10. Brightwater GHG Emissions for Alternative 2C	
Parameter	Value
GHG emissions (CO <sub>2</sub> e MT/yr)	
Nitrous oxide	3,400
Energy	160
Chemicals	6,200
Total	9,800

### 3.4 Scenario 3 – Year-round Nitrogen Removal with Effluent TIN Limit of 3 mg/L

For this scenario, Brightwater would provide year-round nitrogen removal to achieve a TIN concentration of 3 mg/L. This scenario, which represents the typical limits of performance for the best available nitrogen removal technologies, could be a possible scenario for Brightwater if a bubble permit is used (i.e., lower effluent TIN limits for Brightwater and South Plant in exchange for higher effluent TIN limits at West Point). Three alternatives were evaluated for this scenario, as described below. System sizing for these alternatives was based on winter maximum month flow and loading conditions.

Similar to Scenario 2, for all Scenario 3 alternatives, a higher MBR capacity (and thus less bypass) would be needed to achieve the required overall nitrogen removal. As a result, four more membrane basins and a new primary effluent screen would be needed (compared to Alternative 1) to increase the MBR capacity. Aerated grit tank /primary clarifier train 6 was assumed to be added in conjunction with the new primary effluent screen. The existing odor control system for the secondary system would be expanded.

#### 3.4.1 Alternative 3A – SND/MBR + Sidestream Anammox

This alternative is similar to Alternative 2A, but the secondary process would need to achieve the lower TIN limit. Figure 5 shows a process flow schematic for this alternative.

Table 11 summarizes the modeling results and sizing of major facilities and equipment for Alternative 3A. To meet the lower effluent TIN limit, three new aeration basins would be required for this alternative.

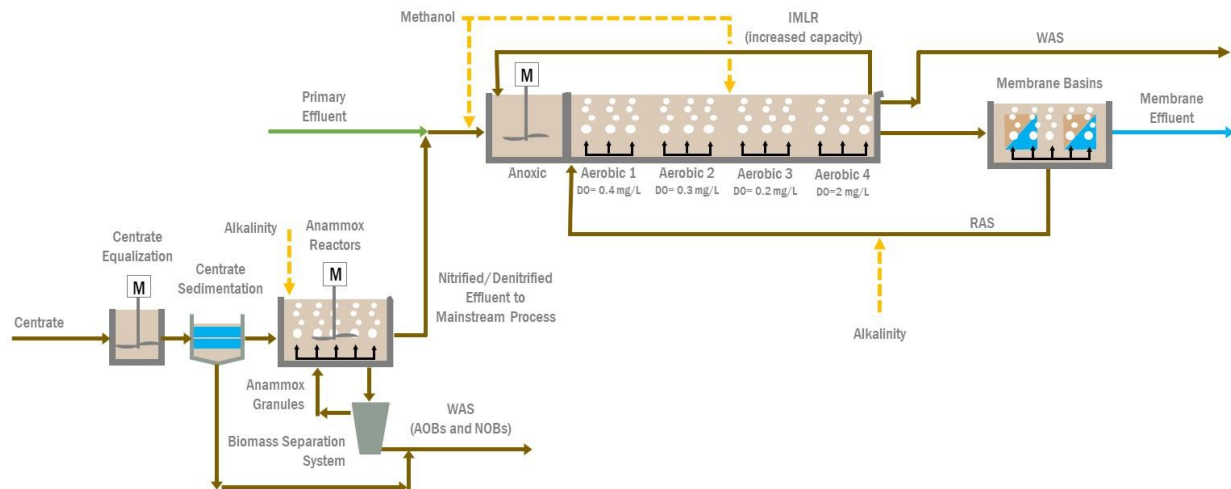

Figure 5. Process flow schematic for Alternative 3A – SND/MBR + sidestream anammox

Table 11. Brightwater Nitrogen Removal Modeling Results and System Sizing for Alternative 3A	
Parameter	Value
Final effluent TIN, mg/L <sup>a</sup>	
@ winter max month flow and load	2.9
@ summer avg dry weather flow and load	3.0
@ winter avg wet weather flow and load	2.9
Overall TN removal, % <sup>a</sup>	
@ winter max month flow and load	88
@ summer avg dry weather flow and load	90
@ winter avg wet weather flow and load	89
Annual average	89
Annual average aeration requirements	
Aeration basin air flow, scfm	15,000
Membrane scouring air flow, scfm	36,000
Annual average supplemental chemical requirements	
Alkalinity (25% caustic), gpd	1,350
Methanol, gpd	1,760
New aeration basins	
Number of new basins	3
Volume per basin, MG	1.55
New membrane basins	
Peak hydraulic capacity (at 10-gfd flux limit)	56
Number of new basins <sup>b</sup>	6
Volume per basin, MG	0.12
Sidestream treatment	
Type	Anammox
Centrate equalization tank volume, gal	60,000
Number of reactor tanks	2
Volume of reactor tanks, gal	118,500

- a. Final effluent concentrations and overall removals accounting for bypass of CEPT effluent around secondary treatment when flow exceeds peak MBR capacity.
- b. Six new basins (membrane basins 11–16), in addition to installing membrane cassettes in basins 9 and 10.





The site layout for Alternative 3A is provided in Attachment A.

**Challenges and Potential Risks.** Constructing aeration basins 5 and 6 would likely require extensive excavation of the east hillside and construction of a retaining wall.

A potential risk for this alternative is the increased difficulty of achieving effluent TIN target in a combined effluent (from tertiary system and CEPT) during winter peak flow conditions, as the CEPT effluent would have higher TIN concentrations than the tertiary effluent. In addition, lower-than-expected membrane permeability during winter peak flow condition would require additional MBR bypass (unless diversion to South Plant is feasible). There would also be very limited space for future aeration basin expansion.

Table 12 summarizes the estimated GHG emissions for Alternative 3A.

Table 12. Brightwater GHG Emissions for Alternative 3A	
Parameter	Value
GHG emissions (CO <sub>2</sub> e MT/yr)	
Nitrous oxide	37,900
Energy	160
Chemicals	2,900
Total	41,000

### 3.4.2 Alternative 3B – 4SMB/MBR + Sidestream Anammox

This alternative is similar to Alternative 3A, but with the aeration basins re-configured for a 4-stage modified Bardenpho (4SMB) instead of modified Ludzack–Ettinger (MLE) process. The 4SMB process is an expansion of the MLE process, with addition of a second set of anoxic and aerobic zones. The mixed liquor leaving the first aerobic zone enters a second anoxic zone where the residual nitrate is further reduced. The second aerated zone serves as a polishing step to nitrify the ammonia formed in the second anoxic zone and to oxidize any residual carbon from the second anoxic zone. External carbon, such as methanol, is required at the second anoxic zone to drive denitrification because readily biodegradable carbon has already been consumed upstream. Figure 6 shows a process flow schematic for this alternative.

Table 13 summarizes the modeling results and sizing of major facilities and equipment for Alternative 3B.

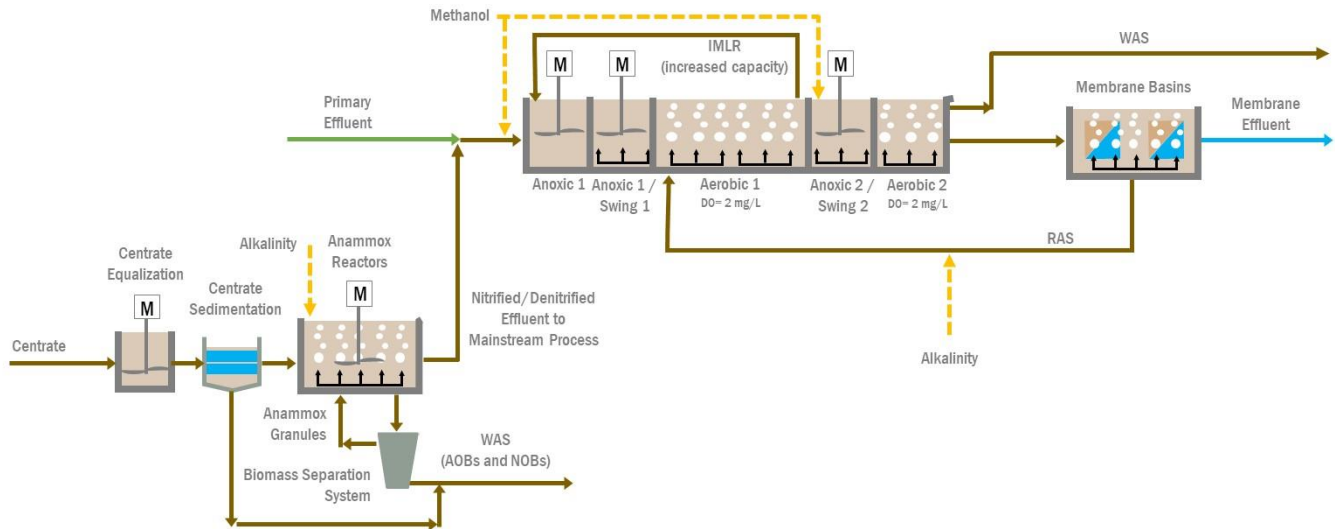

Figure 6. Process flow schematic for Alternative 3B – 4SMB/MBR + sidestream anammox

Table 13. Brightwater Nitrogen Removal Modeling Results and System Sizing for Alternative 3B	
Parameter	Value
Final effluent TIN, mg/L <sup>a</sup>	
@ winter max month flow and load	3.0
@ summer avg dry weather flow and load	2.9
@ winter avg wet weather flow and load	2.9
Overall TN removal, % <sup>a</sup>	
@ winter max month flow and load	87
@ summer avg dry weather flow and load	90
@ winter avg wet weather flow and load	89
Annual average	90
Annual average aeration requirements	
Aeration basin air flow, scfm	14,400
Membrane scouring air flow, scfm	36,000
Annual average supplemental chemical requirements	
Alkalinity (25% caustic), gpd	1,350
Methanol, gpd	1,360
New aeration basins	
Number of new basins	2
Volume per basin, MG	1.55
New membrane basins	
Peak hydraulic capacity (at 10-gfd flux limit)	56
Number of new basins <sup>b</sup>	6
Volume per basin, MG	0.12
Sidestream treatment	
Type	Anammox
Centrate equalization tank volume, gal	60,000
Number of reactor tanks	2
Volume of reactor tanks, gal	118,500

- a. Final effluent concentrations and overall removals accounting for bypass of CEPT effluent around secondary treatment when flow exceeds peak MBR capacity.
- b. Six new basins (membrane basins 11-16), in addition to installing membrane cassettes in basins 9 and 10

A preliminary site layout for Alternative 3B is provided in Attachment A. The layout for this alternative is the similar to that for Alternative 3A, except that there would be two new aeration basins and different internal configuration of the aeration basins, which would be configured for the 4SMB process. This alternative has the same **challenges and potential risks** as Alternative 3A. There would be space for one more aeration basin in the future.

Table 14 summarizes the estimated GHG emissions for Alternative 3B.

Table 14. Brightwater GHG Emissions for Alternative 3B	
Parameter	Value
GHG emissions (CO <sub>2</sub> e MT/yr)	
Nitrous oxide	9,000
Energy	150
Chemicals	2,700
Total	11,800



### 3.4.3 Alternative 3C – MLE/MBR + Tertiary Denitrifying Fixed-Film + Sidestream Anammox

This alternative is similar to Alternative 2C, except for the increased denitrification requirements for the tertiary process. Figure 7 shows a process flow schematic for this alternative.

Table 15 summarizes the modeling results and sizing of major facilities and equipment for Alternative 3C.

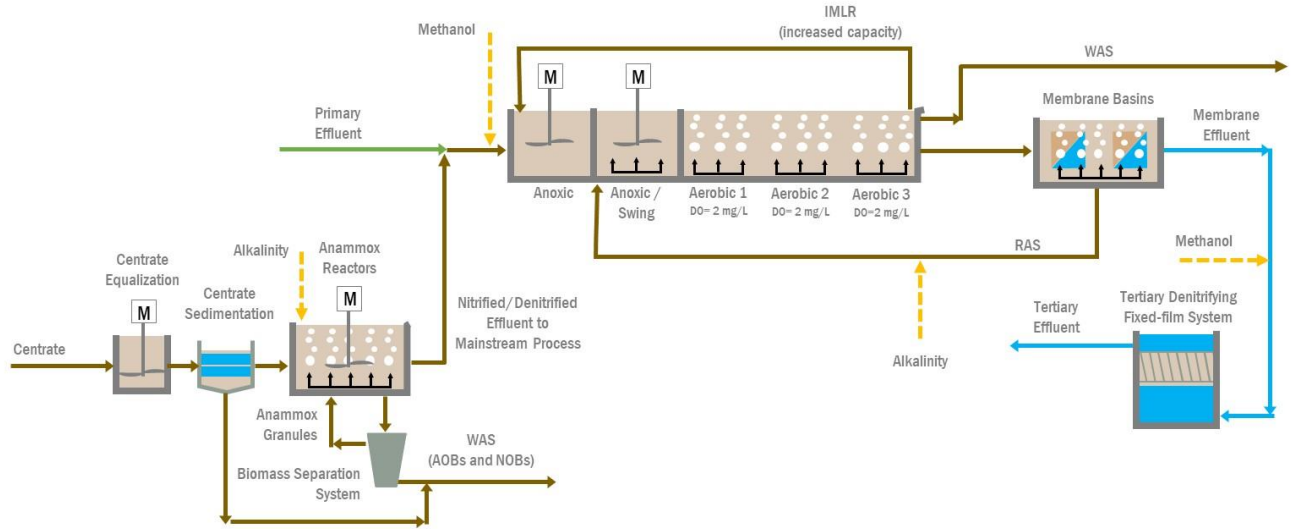

Figure 7. Process flow schematic for Alternative 3C – MLE/MBR + tertiary denitrifying fixed-film + sidestream anammox

Table 15. Brightwater Nitrogen Removal Modeling Results and System Sizing for Alternative 3C	
Parameter	Value
Secondary effluent TIN, mg/L	
@ winter max month flow and load	17
@ summer avg dry weather flow and load	18
@ winter avg wet weather flow and load	18
Final effluent TIN, mg/L <sup>a</sup>	
@ winter max month flow and load	3
@ summer avg dry weather flow and load	3
@ winter avg wet weather flow and load	3
Overall TN removal, % <sup>a</sup>	
@ winter max month flow and load	85
@ summer avg dry weather flow and load	90
@ winter avg wet weather flow and load	89
Annual average	89
Annual average aeration requirements	
Aeration basin air flow, scfm	15,100
Membrane scouring air flow, scfm	36,000
Annual average supplemental chemical requirements	
Alkalinity (25% caustic), gpd	5,200
Methanol, gpd	1,600
New aeration basins	
Number of new basins	1
Volume per basin, MG	1.55



Table 15. Brightwater Nitrogen Removal Modeling Results and System Sizing for Alternative 3C	
Parameter	Value
<b>New membrane basins</b>	
Peak hydraulic capacity (at 10-gfd flux limit)	56
Number of new basins <sup>b</sup>	6
Volume per basin, MG	0.12
<b>Tertiary fixed-film system</b>	
Number of denitrifying cells	8
Total cell volume, MG	0.68
<b>Sidestream treatment</b>	
Type	Anammox
Centrate equalization tank volume, gal	60,000
Number of reactor tanks	2
Volume of reactor tanks, gal	118,500

- a. Final effluent concentrations and overall removals accounting for removals across tertiary process and for bypass of CEPT effluent around secondary treatment when flow exceeds peak MBR capacity.
- b. Six new basins (membrane basins 11–16), in addition to installing membrane cassettes in basins 9 and 10.

A preliminary site layout for Alternative 3C is provided in Attachment A. The layout is similar to that for Alternative 2C, except that the footprint for the tertiary denitrifying fixed-film system is larger. This alternative also has the same **challenges and potential risks** as Alternative 2C.

Table 16 summarizes the estimated GHG emissions for Alternative 3C.

Table 16. Brightwater GHG Emissions for Alternative 3C	
Parameter	Value
<b>GHG emissions (CO<sub>2</sub>e MT/yr)</b>	
Nitrous oxide	3,900
Energy	160
Chemicals	6,600
Total	10,700

## Section 4: Cost Analysis

Cost analysis included developing capital, operations, and maintenance (O&M), and life-cycle costs. This section discusses the assumptions and results of the cost analysis for each alternative.

### 4.1 Capital Costs

Capital costs were developed as pre-Class 5 conceptual cost estimates to provide order-of-magnitude costs. In accordance with WTD estimating guidelines and direction, long-range planning estimated capital project costs developed prior to the more immediate near-term timeline of a class 5 estimate have an anticipated range of -50 percent to +300 percent (or greater) relative accuracy. As part of the WTD estimate development process, various allowances, including allowances for indeterminates (undefined requirements), construction change orders, and project contingencies were included based on Class 5 cost-estimating guidelines. Each estimate provides similar documentation to that of the Association for the Advancement of Cost Engineering international Guidelines and Recommended Practice for a Class 5 estimate and is further supported by recommended practices of WTD planning-level cost estimates.



For each alternative, a total project cost was developed, which includes raw construction costs, contractor markups, allowance for change orders, sales tax, design and construction consulting fees, permitting, WTD staffing, contingency, and other indirect costs. Detailed descriptions of the basis and assumptions used in developing the project cost for each alternative are provided in the Basis of Estimates documents in Attachment C.

#### 4.1.1 Site-Specific Capital Cost Assumptions

Besides general cost estimating assumptions given in the Basis of Estimates, a number of plant-specific and alternative-specific assumptions were also used. These include:

- For all alternatives with SND (Alternatives 1, 2A, and 3A), it was assumed that modifications in the existing aeration basins to operate in SND mode (mainly changes in the air piping and diffuser grids and addition of instrumentation) would have already been implemented in the BWABO project. Therefore, costs for those changes were not included.
- For all alternatives, costs for membrane basins 9 and 10 only include the costs to install membrane cassettes in those basins. No additional ancillary equipment for those basins would be required.
- For Alternative 1, the existing odor control system was assumed to be adequate to treat the additional foul air from the expanded MBR system. Foul air ductwork would need to be extended to aeration basin 4. For the other alternatives, one new odor treatment train was assumed.
- There is sufficient capacity in the existing primary treatment odor control system to accommodate one more train of aerated grit tank/primary clarifier. Therefore, expansion of the primary treatment odor control system was assumed to be not needed for the scenarios 2 and 3 alternatives where the new train would be added.
- No odor control was assumed for the tertiary denitrification fixed-film system.
- For alternatives 2C, 3A, 3B and 3C, the costs for re-routing a roadway and constructing a retaining wall are included to allow construction of new aeration basins and/or the new tertiary denitrification fixed-film system.
- Costs for solids system upgrades were not included in this analysis. The higher waste activated sludge (WAS) production rates for Alternatives 2B, 3A, 3B and 3C, compared with those for Alternative 1 as well as the base case condition, means higher solids loading rates to the digesters and the dewatering system. Based on the results of the Flows and Loads project capacity analysis, the dewatering centrifuges are already at or approaching their operating capacity limits, and the digester capacity limit was predicted to be reached in the 2030s. The need for upgrades of these processes would thus occur sooner for these alternatives. For Alternatives 2C and 3C, tertiary backwash waste is assumed to be routed to the primary clarifiers and then become part of the primary sludge, which would also increase loadings to the solids treatment processes. Backwash waste solids projections are provided in Section 5.2. Impacts of increased solids loads from tertiary nitrogen removal facilities should be further evaluated during design.
- Costs for any stormwater mitigation are not included.
- Complexity factors serve as adjustments to the WTD allied/indirect costs. The factors range from low, to routine, moderate, and high. For Brightwater, routine or moderate complexity factors were assumed,

#### 4.1.2 Summary of Capital Costs

Table 17 summarizes the capital costs for the alternatives.



**Table 17. Summary of Capital Costs for Brightwater Alternatives <sup>a</sup>**

Alternatives	Estimated probable cost of construction bid	Other construction cost	Total direct construction cost	Total indirect non-construction cost	Total Project Cost	Total project cost range	
						Low (-50 percent)	High (+300 percent)
Alt 1: SND/MBR + sidestream anammox	\$56,350,000	\$12,020,000	\$68,370,000	\$56,840,000	<b>\$125,210,000</b>	\$62,610,000	\$500,840,000
Alt 2A: SND/MBR + sidestream anammox	\$143,790,000	\$30,670,000	\$174,460,000	\$147,900,000	<b>\$322,360,000</b>	\$161,180,000	\$1,289,440,000
Alt 2B: MLE/MBR + sidestream anammox	\$145,760,000	\$31,090,000	\$176,850,000	\$149,750,000	<b>\$326,600,000</b>	\$163,300,000	\$1,306,400,000
Alt 2C: MLE/MBR + tertiary denitrifying fixed-film + sidestream anammox	\$206,500,000	\$44,050,000	\$250,550,000	\$205,840,000	<b>\$456,380,000</b>	\$228,190,000	\$1,825,520,000
Alt 3A: SND/MBR + sidestream anammox	\$183,720,000	\$39,180,000	\$222,900,000	\$185,970,000	<b>\$408,870,000</b>	\$204,440,000	\$1,635,480,000
Alt 3B: 4SMB/MBR + sidestream anammox	\$182,020,000	\$38,820,000	\$220,840,000	\$184,400,000	<b>\$405,240,000</b>	\$202,620,000	\$1,620,960,000
Alt 3C: MLE/MBR + tertiary denitrifying fixed-film + sidestream anammox	\$216,960,000	\$46,270,000	\$263,230,000	\$216,540,000	<b>\$479,770,000</b>	\$239,890,000	\$1,919,080,000

a. Unescalated, undiscounted costs in 2020 dollars.



## 4.2 O&M Costs

O&M costs consist of power, chemical, and labor costs. Other O&M costs, including material and equipment replacement and other maintenance costs, are assumed to be insignificant compared to power, chemical and additional labor costs, or the differences for those costs among alternatives are expected to be insignificant. Only O&M costs associated with primary effluent fine screening, secondary system, tertiary denitrifying fixed-film system, and sidestream processes are included in this cost analysis. Electrical costs for motorized equipment were calculated from motor horsepower data provided by the equipment vendors or estimated from process modeling results. Labor costs were calculated from the additional full-time equivalents (FTEs) estimated for the liquid-stream upgrades for each alternative.

### 4.2.1 Site-Specific O&M Cost Assumptions

Plant-specific and alternative-specific O&M cost assumptions include:

- Electrical costs were calculated from a blended rate provided by WTD for Brightwater. Blended rate accounts for both costs based on a unit rate (dollar per kilowatt-hour [\$/kWh]) and demand charges. The blended rate calculated from 6 months of data in 2019 was \$0.0697/kWh.
- Alkalinity control is provided by adding 25 percent caustic solution. Unit cost for the caustic solution was based on data provided by WTD for the Brightwater operation, at \$0.067 per pound or \$0.72 per gallon. A unit cost of \$0.75 per gallon was assumed to account for some potential price variability. Including a 10.1 percent sales tax, a unit cost of \$0.83 per gallon was used.
- Methanol cost is \$2.42 per gallon based on a budgetary unit cost of \$2.20 per gallon provided by Cascade Columbia and 10.1 percent sales tax.
- Costs for sodium hypochlorite and citric acid for membrane cleaning were based on cost data at West Point and Brightwater, at \$0.95 and \$13.66 per gallon for 12.5 percent sodium hypochlorite solution and 50 percent citric acid solution, respectively, both including 10.1 percent sales tax. Annual average consumption rates of each chemical were provided by the MBR supplier (Suez).
- Labor costs for additional FTEs were estimated based on an annual cost of \$204,000 per FTE provided by WTD, which includes salary, benefits, and overhead costs.

### 4.2.2 Summary of O&M Costs

Table 18 summarizes the O&M costs for the scenario 1 through 3 alternatives. As mentioned above, only O&M costs associated with primary effluent fine screening, secondary system, tertiary denitrifying fixed-film system, and sidestream processes are included in these costs.

**Table 18. Summary of Annual O&M Costs for Brightwater Alternatives <sup>a</sup>**

Alternatives	Annual electricity cost	Annual chemical cost	Annual additional FTE cost	Total annual O&M costs
Alt 1: SND/MBR + sidestream anammox	\$1,346,000	\$1,365,000	\$153,000	\$2,864,000
Alt 2A: SND/MBR + sidestream anammox	\$1,556,000	\$2,128,000	\$357,000	\$4,041,000
Alt 2B: MLE/MBR + sidestream anammox	\$1,619,000	\$2,172,000	\$357,000	\$4,148,000
Alt 2C: MLE/MBR + tertiary denitrifying fixed-film + sidestream anammox	\$1,747,000	\$2,824,000	\$561,000	\$5,132,000
Alt 3A: SND/MBR + sidestream anammox	\$1,659,000	\$2,233,000	\$459,000	\$4,351,000
Alt 3B: 4SMB/MBR + sidestream anammox	\$1,652,000	\$1,886,000	\$408,000	\$3,946,000
Alt 3C: MLE/MBR + tertiary denitrifying fixed-film + sidestream anammox	\$1,754,000	\$3,255,000	\$561,000	\$5,570,000



a. Unescalated, undiscounted costs in 2020 dollars. Only electrical, chemical, and additional FTE costs for primary effluent fine screening, secondary system, tertiary processes (if added), and sidestream processes are included.

### 4.3 Life-Cycle Costs

LCCA was performed to estimate the total net present value (NPV) of the capital and O&M costs over a 20-year life-cycle period. The following assumptions were used in the LCCA:

- Capital costs were assumed to be distributed over a 5-year period starting in 2030, representing a cashflow from design to construction completion as follows:
  - 5 percent in year 1
  - 10 percent in year 2
  - 25 percent in year 3
  - 40 percent in year 4
  - 20 percent in year 5
- O&M costs were included for the 20-year period from 2035 to 2054.
- Capital and O&M costs were escalated from the 2020 costs to the design year using an escalation rate of 3 percent.
- The escalated costs were then discounted back to the NPV in 2020 dollars using a discount rate of 5.25 percent.

Table 19 summarizes the life-cycle costs for the scenario 1 through 3 alternatives, as well as the total nitrogen load removed over the 20-year life-cycle period and the cost per pound of nitrogen removed.

Alternatives	Capital costs <sup>a</sup>	O&M costs <sup>a</sup>	NPV	TN removed (lb) <sup>b</sup>	Cost per lb N removed <sup>c</sup>
Alt 1: SND/MBR + sidestream anammox	\$125,210,000	\$57,280,000	(\$129,390,000)	46,616,700	\$2.78
Alt 2A: SND/MBR + sidestream anammox	\$322,360,000	\$80,810,000	(\$293,550,000)	53,915,200	\$5.44
Alt 2B: MLE/MBR + sidestream anammox	\$326,600,000	\$82,950,000	(\$298,050,000)	53,961,000	\$5.52
Alt 2C: MLE/MBR + tertiary denitrifying fixed-film + sidestream anammox	\$456,380,000	\$102,630,000	(\$408,610,000)	53,713,400	\$7.61
Alt 3A: SND/MBR + sidestream anammox	\$408,870,000	\$87,030,000	(\$363,150,000)	62,102,400	\$5.85
Alt 3B: 4SMB/MBR + sidestream anammox	\$405,240,000	\$78,930,000	(\$355,580,000)	62,149,700	\$5.72
Alt 3C: MLE/MBR + tertiary denitrifying fixed-film + sidestream anammox	\$479,770,000	\$111,400,000	(\$431,630,000)	61,935,600	\$6.97

a. Unescalated, undiscounted costs in 2020 dollars.

b. Total nitrogen load removed calculated from the difference between the annual raw influent total Kjeldahl nitrogen load and plant effluent nitrogen load, both based on current rated plant influent flows and loadings, multiplied by 20 for the 20-year life-cycle period.

c. Cost per lb N removed calculated by dividing the 20-year NPV by the total N removed.



## Section 5: Comparison and Ranking of Alternatives

Based on the preliminary site layouts, capital costs, O&M costs, and LCCA results presented above, the alternatives were evaluated using various pre-selected criteria. The preliminary results were presented and discussed with WTD staff in the February 10, 2020, workshop (Workshop 2). The final results incorporate comments from WTD. The following sections provide a summary of the evaluation criteria and results.

### 5.1 Evaluation Criteria and Weighting

Alternatives were compared against both economic and non-economic criteria. Most of these criteria were used in the initial screening of nitrogen-removal technologies and in selecting the technology combination alternatives evaluated in this analysis. To evaluate the final alternatives, a weighting factor was assigned to each criterion. The weighting factor ranged from 1 to 3, with 3 representing the highest weight. For each evaluation criteria, a score ranging from 1 to 10 was assigned to each alternative. The weighted score for that criterion was then calculated as the product of the raw score and the weighting factor. The following provides a summary of the criteria and weighting factors used for this analysis.

#### 5.1.1 Technology Status

Technology status refers to how well-established the technology is in the industry. During the technology screening process, all embryonic technologies (those that have only recently started full-scale installation within the last year or have only in-laboratory or pilot-scale installations) were screened out. As all technologies selected for the final alternatives are considered relatively established, a weighting factor of 1 was used for this evaluation criterion. The main difference in technology status among the alternatives relates to the application of SND. SND is a proven process, albeit in warm climates. Therefore, alternatives with SND operation were given a lower score for this criterion than alternatives without SND operation.

#### 5.1.2 Effluent Nitrogen Load Reduction

Effluent nitrogen load reduction refers to the total nitrogen load removed across the liquid-stream processes. In the analysis, the TN load removed over a 20-year period was calculated for each alternative. The alternative with the highest TN load removed was assigned a score of 10; scores for the other alternatives were estimated relative to that highest TN load removed. As this is considered an important evaluation criterion, a weighting factor of 3 was assigned.

#### 5.1.3 Load Variation Impact

Load variation impact refers to the impact of or ability to handle large variations in load either throughout the day or during storm events. For Brightwater, the ability to better handle load variation for some of the alternatives would have an impact on footprint. It is considered a more important criterion than flow variation impact; therefore, a weighting factor of 2 was assigned.

#### 5.1.4 Flow Variation Impact

Flow variation impact refers to the impact of or ability to handle large variations in flow either throughout the day or during storm events. For Brightwater, all alternatives include MBR secondary treatment with flow exceeding the MBR system capacity receiving CEPT only. Flow variation impact is thus expected to be the same for all alternatives; therefore, a weighting factor of 1 was assigned.

#### 5.1.5 Space for Future Expansion

Space for future expansion refers to space available for future plant expansion after construction of the new and modified facilities for each alternative. As Brightwater is a footprint-constrained site, this is an important evaluation criterion and a weighting factor of 3 was assigned.

### 5.1.5 Impacts to Other Processes

This criterion refers to potential impacts to other treatment processes within the WWTP. For this analysis, the impacts were mainly based on total solids production rates, which affect the capacity requirements for the solids treatment processes. A weighting factor of 1 was assigned for this criterion.

### 5.1.6 GHG Emissions

This criterion refers to the GHG emissions estimated from energy and chemical usage and nitrous oxide emissions from denitrification processes. A weighting factor of 2 was assigned for this criterion.

### 5.1.7 CEC and Toxics Removal Potential

Compounds of emerging concern (CEC) and toxics removal potential refers to the ability of the treatment processes to remove CEC and toxics. For this analysis, only removals across the mainstream activated sludge process was considered. For Brightwater, since all alternatives include MBR, which is a long SRT process, the potential for CEC and toxics removal is expected to be similar for all alternatives. Therefore, a weighting factor of 1 was assigned to this criterion.

### 5.1.10 Capital Cost

Capital costs refer to the total project costs provided in Table 17. Alternative 1, with the least amount of capital improvements and thus the lowest project costs, was assigned a score of 10. Scoring of the other alternatives was made mainly by comparing alternatives within each scenario, and not strictly based on the capital costs for each alternative relative to the capital cost for Alternative 1. A weighting factor of 3 was assigned to this criterion.

### 5.1.11 O&M Cost

O&M costs include costs for energy use, chemical consumption, and increased labor (FTEs) associated with the mainstream and sidestream processes considered in this evaluation, as shown in Table 18. Alternative 1, with the lowest O&M cost, was assigned a score of 10. Scoring of the other alternatives was made mainly by comparing alternatives within each scenario, and not strictly based on the O&M costs for each alternative relative to the O&M costs for Alternative 1. A weighting factor of 3 was assigned to this criterion.

### 5.1.12 Supplementary Carbon Source Flexibility

Supplemental carbon source flexibility refers to the potential of the process to use alternatives to purchased external supplemental carbon sources for denitrification, such as methanol and acetic acid. This analysis assumed methanol as the supplemental carbon source for all alternatives to provide a baseline for costing and comparison between alternatives. To reduce operating costs associated with purchasing supplemental carbon, it may be possible to use a carbon source that is generated internally to the plant through fermentation processes, such as primary sludge fermentation; however, primary sludge fermentation would require additional upgrades and infrastructure for the fermentation facilities. In addition, primary sludge fermentation would release additional nitrogen that would be added to the treatment process. For this evaluation, all alternatives considered would be compatible with using primary sludge fermentate in lieu of methanol as the supplemental carbon source or to reduce methanol requirements; however, because fermentate contributes an additional nitrogen load, its use in a tertiary process (such as the tertiary denitrifying filters for some of the alternatives in this analysis) would likely be limited. Similarly, fermentate would be less likely to be used in the second anoxic zone of a 4SMB process when trying to achieve very low effluent TIN limits (e.g., 3 mg/L). Therefore, alternatives with a tertiary denitrifying process or 4SMB process were assigned slightly lower scores for supplemental carbon source flexibility. A weighting factor of 2 was assigned to this criterion.

### **5.1.13 Risks**

The risks criterion was added to account for potential risks not already captured as part of the other scoring criteria. One potential risk is the increased difficulty to achieve the effluent TIN target in a combined effluent (from MBR and CEPT) during winter peak flow conditions (without transferring flows to other plants) because the CEPT effluent would have higher TIN concentrations than the MBR effluent. Currently, the ability to bypass flow that receives CEPT only is limited by the need to meet net environmental benefit (NEB) requirements in the current NPDES permit. With a TIN limit, CEPT bypass would be limited more by the need to achieve the necessary overall nitrogen removal instead of the NEB requirements. The additional infrastructures (including primary effluent screens and membrane basins) required to treat the higher flows in the MBR system during peak flow events are accounted for in this analysis, but the impact of peak flows on capital upgrades would need to be further evaluated in future studies. Another potential risk is reduced membrane flux/permeability restricting secondary treatment capacity. Potential risks for each alternative are listed in the notes on the preliminary site layouts in Attachment A. They are also provided in the description of each alternative in Section 3. A weighting factor of 1 was assigned to this criterion.

### **5.1.14 Constructability**

Constructability refers to the ease of building while minimizing impacts to facility operation and the ability to meet current permit limits. In general, alternatives with higher footprint requirements or difficult retrofit of existing aeration basins (such as for converting to a 4SMB process) will have a lower score for constructability. A weighting factor of 2 was assigned to this criterion. A higher weighing factor (3) was not used as it may be possible to divert flow to South Plant during construction.

### **5.1.15 Operational Complexity**

Operational complexity refers to the ease of operating and maintaining the process. For example, a conventional system expansion that results in a process similar to the existing process (such as maintaining MLE) would have low operational complexity and be given a higher score. A process that requires significantly more equipment for maintenance, equipment that requires more frequent maintenance, or a process that is more complex to operate and requires additional instrumentation or monitoring to ensure process stability would be given a lower score. A weighting factor of 2 was assigned to this criterion.

## 5.2 Evaluation Results

To facilitate comparison of alternatives, the modeling, LCCA, and GHG emissions results for the secondary, tertiary, and sidestream treatment processes for all alternatives are summarized in Table 20; a comparative plot of GHG emissions is shown on Figure 8. For comparison, Figure 8 and Table 20 also show GHG emissions and nitrogen removal performance for the base case, which is defined as similar to Alternative 1 but without sidestream anammox (see description in Section 3.1). In general, the greater amount of nitrogen removed, the higher the GHG emissions; however, the increasing trend is more dependent on the technologies used for the alternatives. Estimated GHG emissions are consistently higher for SND alternatives because of the high nitrous oxide emissions estimated for SND operation. These nitrous oxide emission estimates are based on relatively few research studies that have been conducted for the emissions from SND and are likely conservative. GHG emissions associated with energy demand are not evident in the bars on Figure 8 as they are negligible compared to GHG emissions associated with nitrous oxide and chemicals. It is important to note that the GHG emissions for production of the electricity supplied to Brightwater are relatively low compared to most locations in the United States. While SND operation generally provides savings in electricity compared to non-SND operation, the corresponding reduction in GHG emissions is significantly overshadowed by the increase in GHG emissions due to nitrous oxides emissions. SND may be more advantageous for lowering GHG emissions at other locations where the GHG emission factor for electricity production is higher. Scoring of all alternatives is summarized on Figure 9.

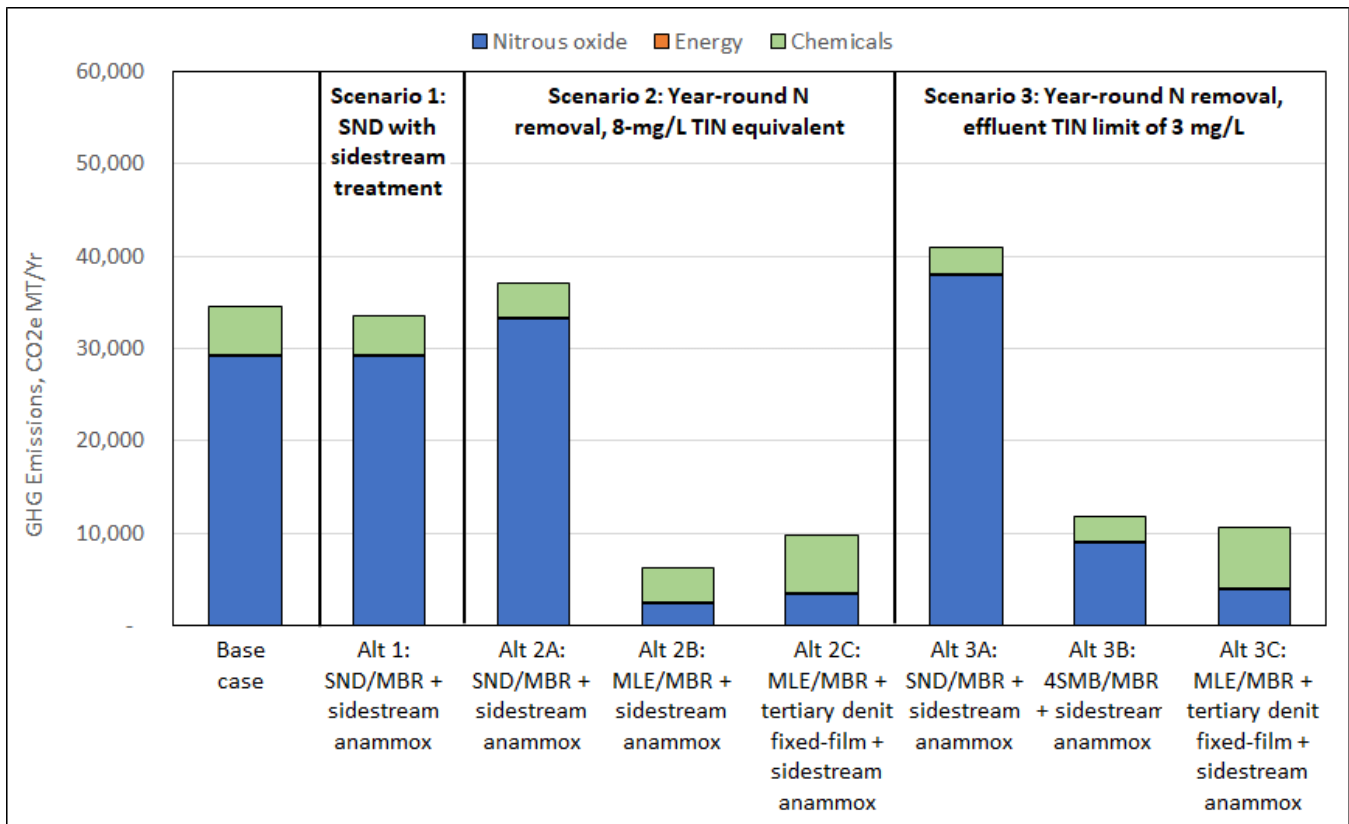

Figure 8. Comparison of estimated GHG emissions

**Table 20. Comparison of Alternatives – Modeling and LCCA Results**

Alternative		Base case <sup>e</sup>	1	2A	2B	2C	3A	3B	3C
Scenario modifications or effluent limits/targets		-	SND with sidestream treatment	Year-round N removal, 8-mg/L TIN equivalent			Year-round N removal, effluent TIN limit of 3 mg/L		
Alternative description		SND/MBR	SND/MBR + sidestream anammox	SND/MBR + sidestream anammox	MLE/MBR + sidestream anammox	MLE/MBR + tertiary denitrifying fixed-film + sidestream anammox	SND/MBR + sidestream anammox	4SMB/MBR + sidestream anammox	MLE/MBR + tertiary denitrifying fixed-film + sidestream anammox
Parameter	Units	Value							
<b>Cost estimates and LCCA results</b>									
Capital cost (total project cost) <sup>a</sup>	-	-	\$125,210,000	\$322,360,000	\$326,600,000	\$456,380,000	\$408,870,000	\$405,240,000	\$479,770,000
O&M cost (20-year) <sup>a, b</sup>	-	-	\$57,280,000	\$80,810,000	\$82,950,000	\$102,630,000	\$87,030,000	\$78,930,000	\$111,400,000
NPV (20-year)	-	-	(\$129,390,000)	(\$293,550,000)	(\$298,050,000)	(\$408,610,000)	(\$363,150,000)	(\$355,580,000)	(\$431,630,000)
Power consumption	kWh/yr	-	19,311,300	22,321,400	23,220,900	25,066,000	23,806,300	23,707,300	25,170,700
<b>Anticipated performance</b>									
Effluent TIN, summer average	mg/L	15.4	10.6	3.0	6.5	< 3	3.0	2.9	< 3
Effluent TIN, winter average	mg/L	17.6	13.6	11.9	8.9	< 12	2.9	2.9	< 3
TN removal efficiency, summer average	-	62%	73%	90%	82%	90%	90%	90%	90%
TN removal efficiency, winter average	-	52%	62%	66%	74%	66%	89%	89%	89%
TN removal efficiency, annual average	-	57%	67%	78%	78%	77%	90%	90%	89%
TN removed, annual average	lb/d	5,389	6,386	7,386	7,392	7,358	8,507	8,514	8,484
TN removed over 20-year period	lb	39,341,700	46,616,700	53,915,200	53,961,000	53,713,400	62,102,400	62,149,700	61,935,600
Cost of N removal <sup>c</sup>	\$/lb N	-	\$2.78	\$5.44	\$5.52	\$7.61	\$5.85	\$5.72	\$6.97
<b>Biosolids impacts</b>									
WAS production, peak month	lb TSS/d	22,976	22,585	25,163	27,141	24,026	29,044	28,678	24,026
Backwash waste solids production, peak month	lb TSS/d	-	-	-	-	4,500	-	-	7,600
Biosolids production, peak month	DT/d	15.6	15.6	15.3	15.7	16.1	16.0	15.9	16.8
<b>Sustainability analysis results</b>									
GHG emissions, nitrous oxide	CO <sub>2</sub> e MT/yr	29,149	29,192	33,268	2,348	3,407	37,891	9,006	3,945
GHG emissions, energy	CO <sub>2</sub> e MT/yr	127	126	145	151	163	155	154	164
GHG emissions, chemicals	CO <sub>2</sub> e MT/yr	5,208	4,167	3,757	3,795	6,214	2,947	2,655	6,577
GHG emissions, total	CO <sub>2</sub> e MT/yr	34,484	33,484	37,171	6,294	9,784	40,992	11,815	10,685
<b>Other considerations</b>									
Implementation timeframe <sup>d</sup>	-	-	5-7 years	8-10 years	8-10 years	8-10 years	10-12 years	10-12 years	10-12 years
Site layout issues/constraints	-	-	See notes on site layouts.						
Implementation challenges or constructability considerations	-	-							

a. Capital and O&M costs are presented in 2020 dollars.

b. O&M costs are for electricity, chemicals, and additional FTEs only.

c. Cost of N removal calculated as TN removed over 20-year period divided by 20-year NPV.

d. Estimated duration for planning, design, and construction.

e. The base case is assumed to be the same as Alternative 1 without sidestream anammox (includes one new aeration basin and four new membrane basins to meet net environmental benefit requirements at the current rated flows and loads).

DT = dry tons



Alternative		1	2A	2B	2C	3A	3B	3C
Scenario modifications or effluent limits/targets		SND with sidestream treatment	Year-round N removal, 8-mg/L TIN equivalent			Year-round N removal, effluent TIN limit of 3 mg/L		
Alternative description		SND/MBR + sidestream anammox	SND/MBR + sidestream anammox	MLE/MBR + sidestream anammox	MLE/MBR + tertiary denitrifying fixed-film + sidestream anammox	SND/MBR + sidestream anammox	4SMB/MBR + sidestream anammox	MLE/MBR + tertiary denitrifying fixed-film + sidestream anammox
Scoring criteria	Weight <sup>b</sup>	Score <sup>a</sup>						
Technology status	1	8	8	10	10	8	10	10
Effluent N load reduction	3	6	8	8	8	10	10	10
Load variation impact	2	5	5	5	7	5	5	7
Flow variation impact	1	3	3	3	3	3	3	3
Space for future expansion	3	8	7	7	5	4	5	5
Impacts to other processes	1	6	6	6	4	6	6	4
GHG emissions	2	2	2	9	6	1	5	5
CEC and toxics removal potential <sup>c</sup>	1	6	6	6	6	6	6	6
Capital cost	3	9	8	8	3	7	7	3
O&M cost	3	8	7	6	3	6	7	2
Supplemental carbon source flexibility	2	5	5	5	3	5	4	3
Risks	1	5	5	5	6	5	5	7
Constructability	2	8	7	6	3	7	4	3
Operational complexity	2	6	5	7	4	4	6	4
<b>Total un-weighted score</b>		<b>85</b>	<b>82</b>	<b>91</b>	<b>71</b>	<b>77</b>	<b>83</b>	<b>72</b>
<b>Total weighted score</b>		<b>173</b>	<b>166</b>	<b>181</b>	<b>132</b>	<b>153</b>	<b>165</b>	<b>134</b>

Notes:  
a. Score of 1 to 10, where 10 represents the greatest benefit or lowest cost, footprint, emissions, etc.  
b. Score of 1 to 3, where 3 represents the highest weighting factor.  
c. CEC and toxics removal potential only considers the mainstream activated sludge process. In general, longer SRT systems (MBR) have higher potential removal, while seasonal N removal options have lower potential.

Figure 9. Comparison of alternatives—scoring results



## Section 6: Summary

Rather than selecting preferred alternatives for each nitrogen removal scenario, the task team decided during Workshop 2 that the evaluation results would be most beneficial if used to represent a range of potential costs and other impacts for each scenario. This approach recognizes that future alternatives analyses would be required during planning and design to select the preferred upgrade approach for Brightwater once actual nitrogen limits and the timing of nitrogen limits are known. Overall, key conclusions from the Brightwater analysis of planning alternatives include:

- Large portions of the capital cost for the alternatives investigated in this study are associated with base case upgrades that are required for all alternatives to achieve the current Brightwater rated capacity, regardless of specific nitrogen removal limits considered for the various scenarios.
  - For example, approximately 67 percent of the capital cost for Alternative 1 is associated with base case upgrades to the secondary treatment system, including construction of aeration basin 4, installing cassettes in membrane basins 9 and 10, and constructing membrane basins 11 and 12.
  - The additional membrane basin expansion is based on current hydraulic limits for the membranes during winter conditions and could potentially be reduced if additional hydraulic capacity can be achieved with the existing membranes (currently being investigated as part of the BWABO Project).
  - The scenario 2 and 3 alternatives also include construction of new primary treatment and odor control systems, which are also linked more to capacity-related upgrades than upgrades that would be triggered by nitrogen removal limits.
- All alternatives that evaluated SND as part of the main biological process used uniform assumptions around operating DO and bacterial kinetics based on the consultant's experience at other facilities. Actual SND performance, including alternate aeration control strategies that could improve nitrogen removal performance, will be demonstrated as part of the BWABO project. As such, observations and updated model calibrations from this demonstration should be done as part of any future planning project.
- The implementation of SND as part of the BWABO Project will improve overall nitrogen removal at Brightwater, but SND alone is unlikely to be capable of achieving some of the potential effluent TIN limits. SND in combination with sidestream anammox (Alternative 1) can further reduce effluent TIN (by about 5 mg/L from the base case), but nitrogen removal performance may still not be capable of achieving a year-round effluent TIN of 8 mg/L without supplemental carbon addition.
- This study suggests that the SND alternatives may have significantly higher GHG emissions based on literature emissions factors for nitrous oxide. Impacts of SND operation on nitrous oxide emissions should be further evaluated as part of a future study based on information gathered from full-scale SND operation at Brightwater. In addition, GHG emissions due to nitrous oxide emissions may be lower than those estimated in this study if a portion of the nitrous oxide is removed across the odor control system for the aeration basins and membrane basins.
- Results from this study indicate that it will be feasible to achieve year-round effluent TIN limits of either 8 mg/L (scenario 2) or 3 mg/L (scenario 3) while staying within the existing site footprint. However, some alternatives do require expansion of secondary and/or tertiary treatment processes into the existing hillside on the east side of the site.
  - Results suggest that it would be feasible to achieve a year-round effluent TIN of 8 mg/L using either SND or MLE mainstream processes in combination with sidestream anammox (Alternatives 2A and

- 2B). The use of an MLE mainstream process with a tertiary denitrifying fixed-film process (Alternative 2C) is also feasible but would likely have comparatively higher capital and O&M costs.
- Capital costs of scenario 2 alternatives are similar for Alternatives 2A and 2B, ranging from approximately \$322 million to \$327 million, or up to \$1.3 billion (+300 percent) based on the upper end of the cost estimate accuracy range. The capital cost for Alternative 2C is much higher, estimated at approximately \$456 million, or up to \$1.8 billion (+300 percent) based on the upper end of the cost estimate accuracy range.
- Results indicate that it would be feasible to achieve a year-round effluent TIN limit of 3 mg/L using either SND or 4SMB mainstream processes in combination with sidestream anammox (Alternatives 3A and 3B). The use of an MLE mainstream process with a tertiary denitrifying fixed-film process (Alternative 3C) is also feasible but would likely have comparatively higher capital and O&M costs. However, the use of tertiary treatment for this scenario does offset the required size of the aeration basin expansion. All of the alternatives for scenario 3 require excavating a portion of the east hillside. Without a tertiary process, there would be very limited space for future expansion that requires additional aeration basins without further excavation of the east hillside.
- Capital costs of scenario 3 alternatives range from approximately \$405 million to \$480 million, or up to \$1.9 billion (+300 percent) based on the upper end of the cost estimate accuracy range. Alternatives 3A and 3B have similar capital costs, but Alternative 3B would require significant retrofits to the existing aeration basins to accommodate the 4SMB process, whereas SND will already be implemented in the existing aeration basins as part of the BWABO Project. As described above, future studies would be required to reassess the performance of SND and compare to 4SMB for this type of low effluent TIN scenario. Tertiary denitrification does offer more benefit for scenario 3 compared to scenario 2 but has the highest capital and O&M costs of the scenario 3 alternatives.
- Results from this study indicate that as the level of nitrogen removal increases, costs for labor (expressed as additional FTEs), power, and chemicals would generally increase. The exception is Alternative 3B (4SMB/MBR + sidestream anammox), which has lower chemical costs than the scenario 2 alternatives because of significant reduction in alkalinity demand with only a relatively small increase in methanol demand. GHG emissions also follow an increasing trend as the level of nitrogen removal increases, but the increasing trend is more dependent on the technologies used for the alternatives. Estimated GHG emissions are consistently higher for SND alternatives because of the high nitrous oxide emissions estimated for SND operation based on available literature.
- A potential risk at Brightwater is the increased difficulty to meet a TIN limit in a combined effluent (from MBR and CEPT) during winter peak flow conditions because CEPT effluent would have higher TIN concentration than the MBR effluent. It was also assumed that there would be no flow transfers to other plants when the MBR system capacity is exceeded. In order to achieve the necessary nitrogen removal (by limiting CEPT bypass), additional infrastructures (including primary effluent screens and membrane basins) would be required to treat the high flows in the MBR system during peak flow events. These are accounted for in this analysis, but the impact of peak flows on capital upgrades would need to be further evaluated in future studies.
- All modeling and sizing conducted for this study was based on the current rated flows and loads for Brightwater. Further evaluation would be needed to assess impacts of operation at actual and projected flows and loads.

## Attachment A: Site Layouts

---





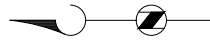

INSTALL CASSETTES IN MEMBRANE BASINS 9-10 AND CONSTRUCT MEMBRANE BASINS 11-12

NEW AERATION BASIN 4 (INCLUDES BLOWER ROOM AND MEMBRANE FEED PUMP EXPANSIONS)

NEW SIDESTREAM ANAMMOX SYSTEM

RESERVED SPACE FOR FUTURE EXPANSION

RESERVED SPACE FOR FUTURE EXPANSION

RESERVED SPACE FOR FUTURE EXPANSION

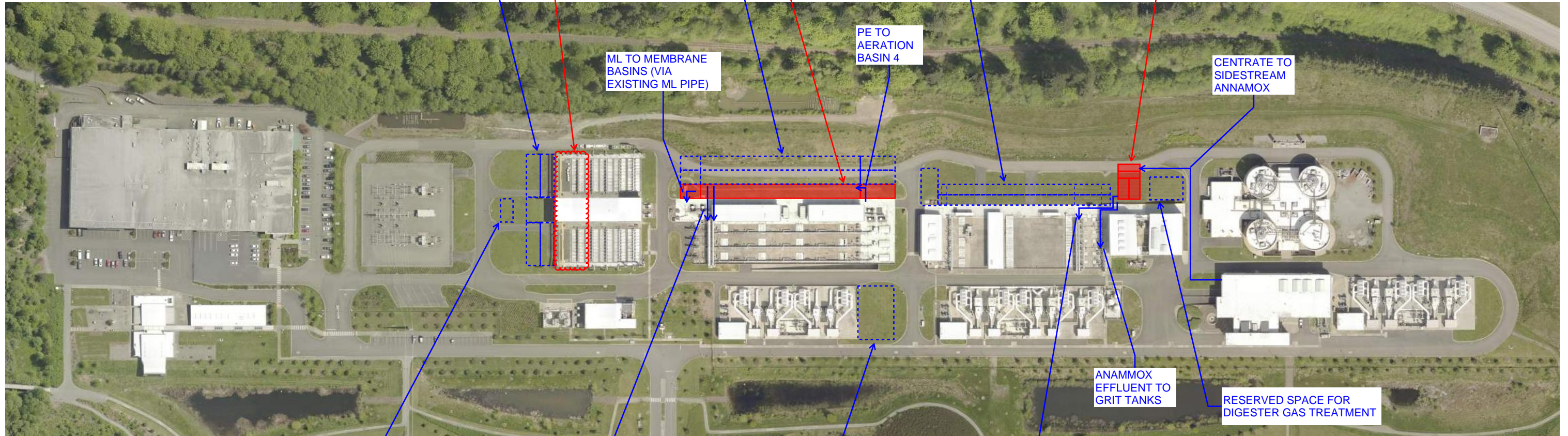

ML TO MEMBRANE BASINS (VIA EXISTING ML PIPE)

PE TO AERATION BASIN 4

CENTRATE TO SIDESTREAM ANAMMOX

RESERVED SPACE FOR BWABO CLASSIFYING SELECTOR

FOUL AIR TO EXISTING DUCTWORK

RESERVED SPACE FOR FUTURE EXPANSION

FOUL AIR TO EXISTING DUCTWORK

ANAMMOX EFFLUENT TO GRIT TANKS

RESERVED SPACE FOR DIGESTER GAS TREATMENT

Implementation challenges or constructibility considerations:  
-Can be constructed with minimal impacts to existing plant operations (assumes SND already implemented as part of BWABO Project)

NOTE: SITE LAYOUT DESIGNED FOR CURRENT PLANT RATED CAPACITY.

BRIGHTWATER TREATMENT PLANT NITROGEN REMOVAL STUDY

SCENARIO 1: SND WITH SIDESTREAM TREATMENT

ALT 1: SND/MBR + SIDESTREAM ANAMMOX



SCALE:  
1" = 200'





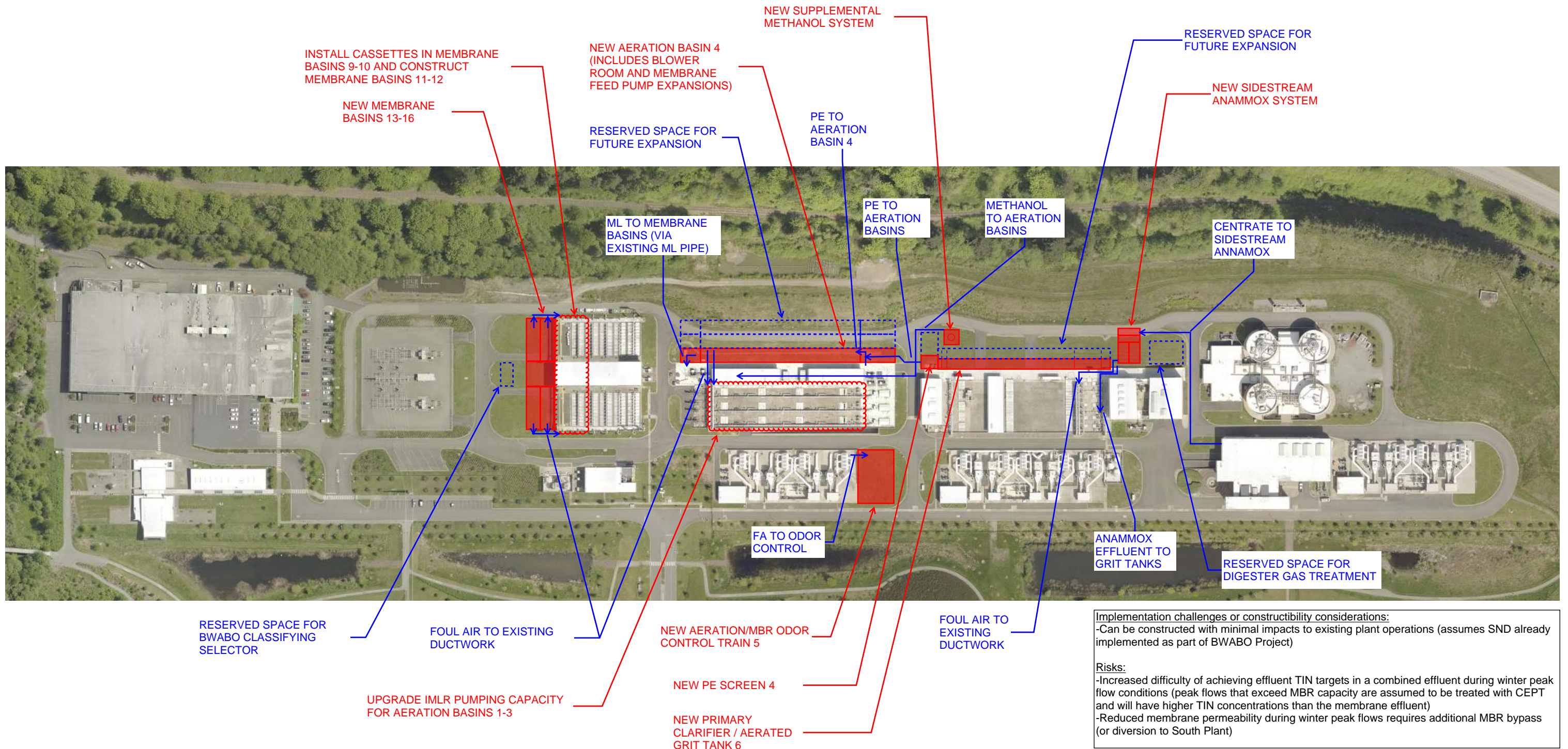
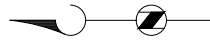

**Implementation challenges or constructibility considerations:**  
 -Can be constructed with minimal impacts to existing plant operations (assumes SND already implemented as part of BWABO Project)

**Risks:**  
 -Increased difficulty of achieving effluent TIN targets in a combined effluent during winter peak flow conditions (peak flows that exceed MBR capacity are assumed to be treated with CEPT and will have higher TIN concentrations than the membrane effluent)  
 -Reduced membrane permeability during winter peak flows requires additional MBR bypass (or diversion to South Plant)

NOTE: SITE LAYOUT DESIGNED FOR CURRENT PLANT RATED CAPACITY.

BRIGHTWATER TREATMENT PLANT NITROGEN REMOVAL STUDY  
 SCENARIO 2: YEAR-ROUND NITROGEN REMOVAL, 8-MG/L TIN EQUIVALENT  
 ALT 2A: SND/MBR + SIDESTREAM ANAMMOX

SCALE:  
 1" = 200'





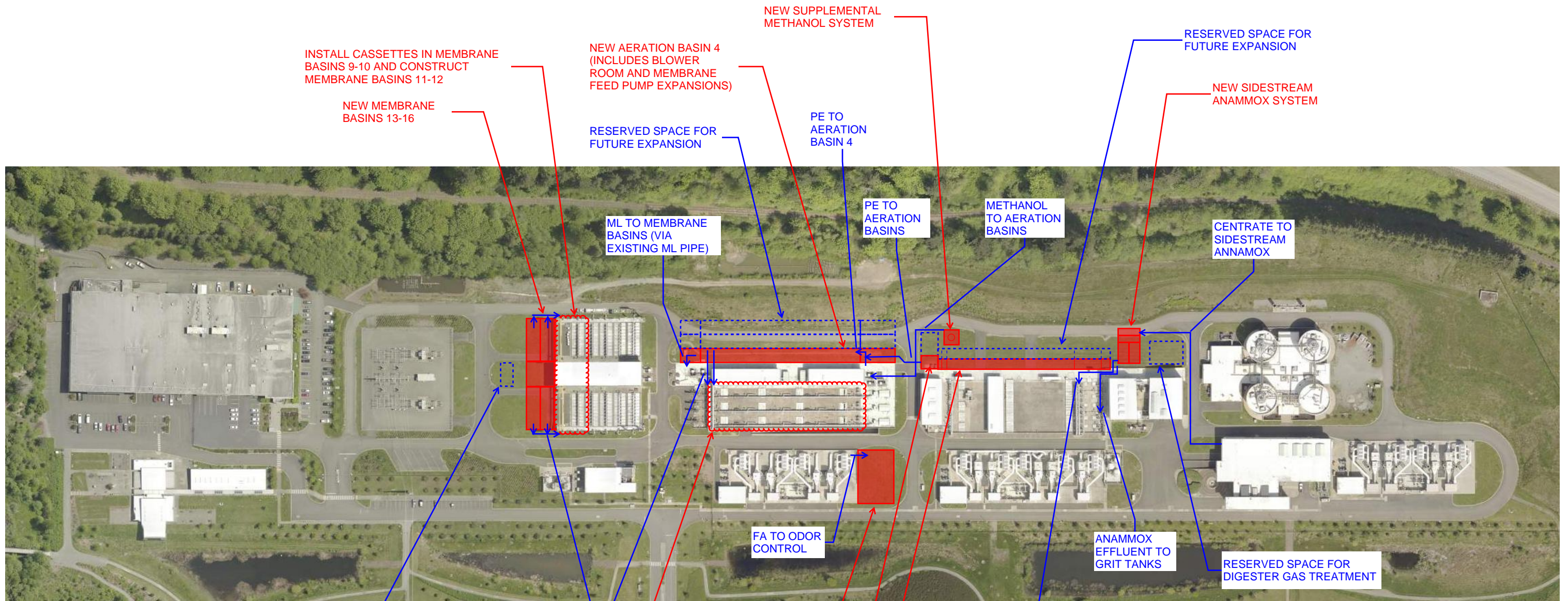
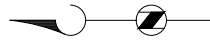

RETROFIT AERATION BASINS 1-3 FOR OPTIMIZED MLE:  
 -CONVERT AERATION ZONE 1 TO ANOXIC/SWING ZONE  
 -UPGRADE IMLR PUMPING CAPACITY

**Implementation challenges or constructibility considerations:**  
 -Can be constructed with minimal impacts to existing plant operations, but likely requires more retrofits to existing aeration basins than SND (assumes SND already implemented as part of BWABO Project)

**Risks:**  
 -Increased difficulty of achieving effluent TIN targets in a combined effluent during winter peak flow conditions (peak flows that exceed MBR capacity are assumed to be treated with CEPT and will have higher TIN concentrations than the membrane effluent)  
 -Reduced membrane permeability during winter peak flows requires additional MBR bypass (or diversion to South Plant)

NOTE: SITE LAYOUT DESIGNED FOR CURRENT PLANT RATED CAPACITY.

BRIGHTWATER TREATMENT PLANT NITROGEN REMOVAL STUDY  
 SCENARIO 2: YEAR-ROUND NITROGEN REMOVAL, 8-MG/L TIN EQUIVALENT  
 ALT 2B: MLE/MBR + SIDESTREAM ANAMMOX



SCALE:  
 1" = 200'





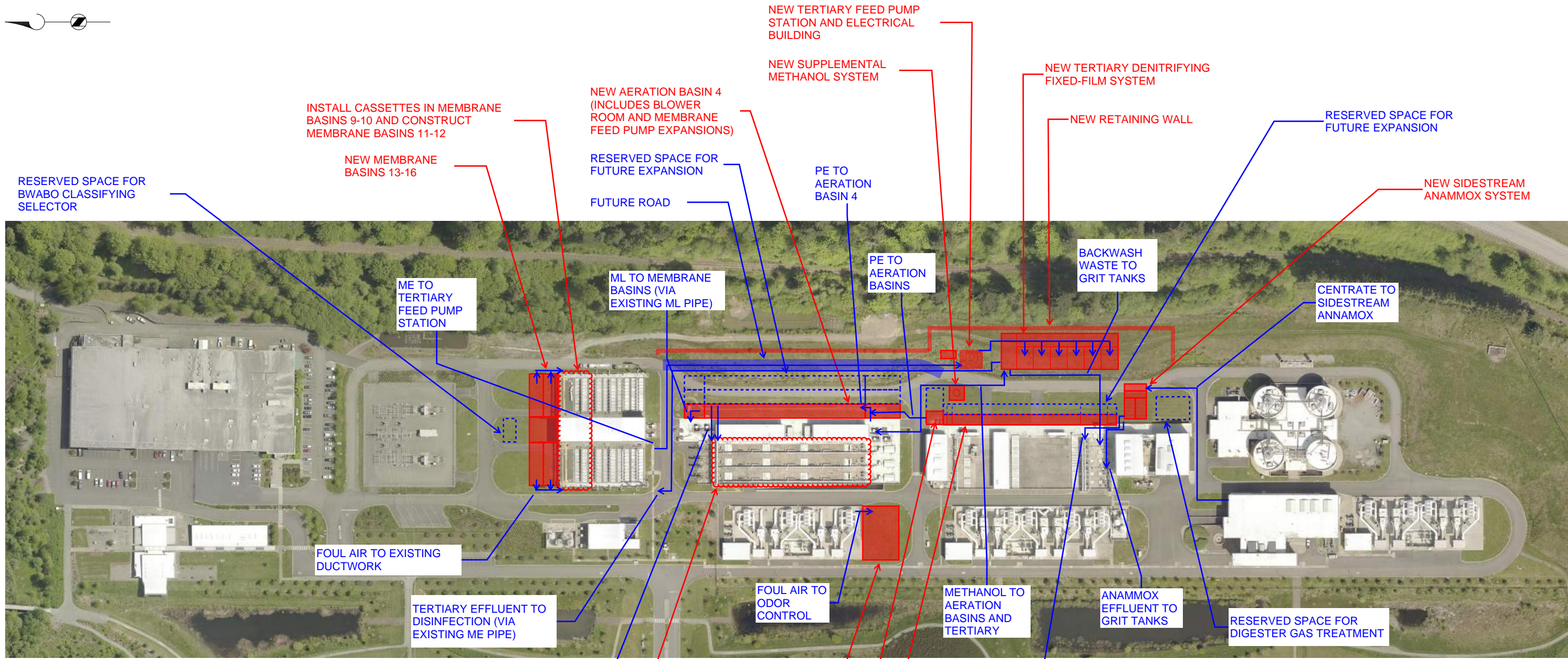
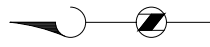

RETROFIT AERATION BASINS 1-3 FOR OPTIMIZED MLE:  
 -CONVERT AERATION ZONE 1 TO ANOXIC/SWING ZONE  
 -UPGRADE IMLR PUMPING CAPACITY

**Site layout issues/constraints:**  
 -Assumes routing of large-diameter membrane effluent piping and tertiary effluent piping can fit in area between existing aeration and membrane basins

**Implementation challenges or constructibility considerations:**  
 -Constructing the tertiary denitrifying fixed-film system will likely require extensive excavation of the east hillside and construction of a retaining wall (layout assumes that the retaining wall would be extended for full length of aeration basins to provide space for tertiary piping)  
 -Can be constructed with minimal impacts to existing plant operations, but likely requires more retrofits to existing aeration basins than SND (assumes SND already implemented as part of BWABO Project)

**Risks:**  
 -Increased difficulty of achieving effluent TIN targets in a combined effluent during winter peak flow conditions (peak flows that exceed MBR capacity are assumed to be treated with CEPT and will have higher TIN concentrations than the tertiary effluent)  
 -Reduced membrane permeability during winter peak flows requires additional MBR bypass (or diversion to South Plant)

NOTE: SITE LAYOUT DESIGNED FOR CURRENT PLANT RATED CAPACITY.

BRIGHTWATER TREATMENT PLANT NITROGEN REMOVAL STUDY  
 SCENARIO 2: YEAR-ROUND NITROGEN REMOVAL, 8-MG/L TIN EQUIVALENT  
 ALT 2C: MLE/MBR + TERTIARY DENITRIFYING FIXED-FILM + SIDESTREAM ANAMMOX

SCALE:  
 1" = 200'





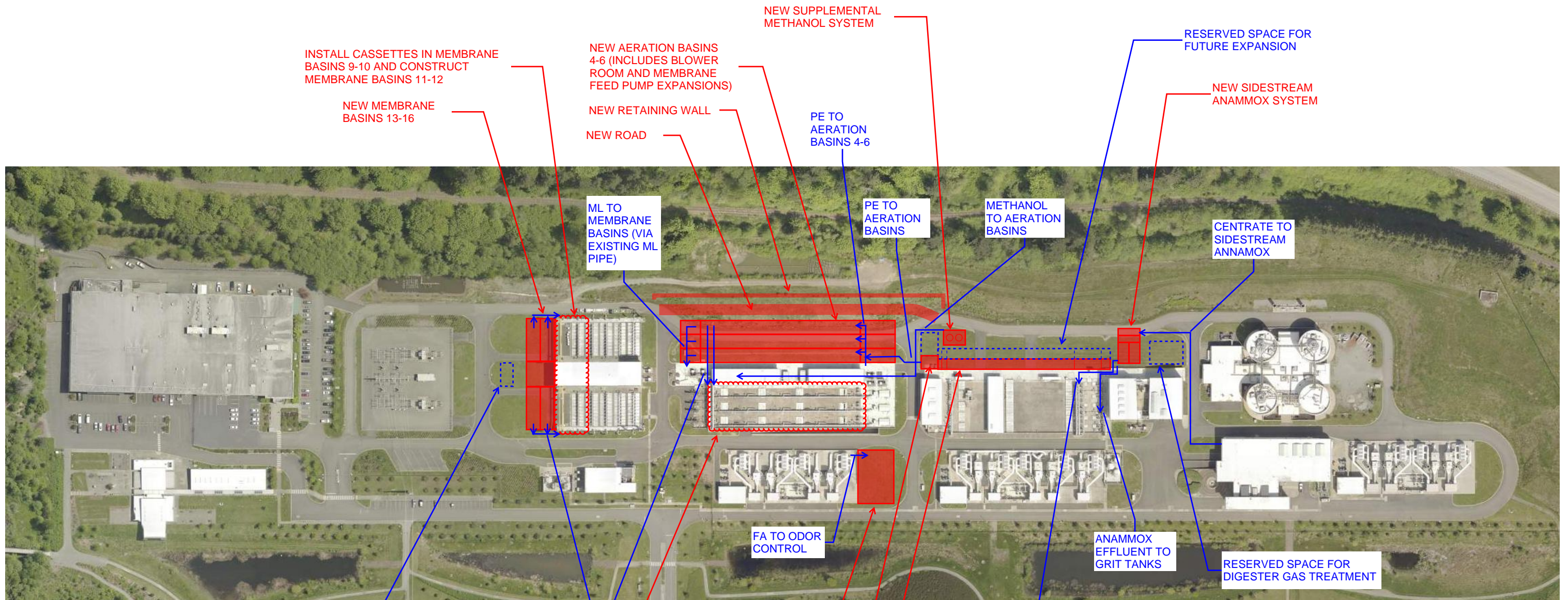
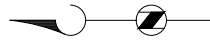

**Implementation challenges or constructibility considerations:**  
 -Constructing aeration basins 5 and 6 will likely require extensive excavation of the east hillside and construction of a retaining wall

**Risks:**  
 -Increased difficulty of achieving low effluent TIN concentrations in a combined effluent during winter peak flow conditions (peak flows that exceed MBR capacity are assumed to be treated with CEPT and will have higher TIN concentrations than the membrane effluent)  
 -Reduced membrane permeability during winter peak flows requires additional MBR bypass (or diversion to South Plant)

NOTE: SITE LAYOUT DESIGNED FOR CURRENT PLANT RATED CAPACITY.

BRIGHTWATER TREATMENT PLANT NITROGEN REMOVAL STUDY  
 SCENARIO 3: YEAR-ROUND NITROGEN REMOVAL, EFFLUENT TIN LIMIT OF 3 MG/L  
 ALT 3A: SND/MBR + SIDESTREAM ANAMMOX

SCALE:  
 1" = 200'





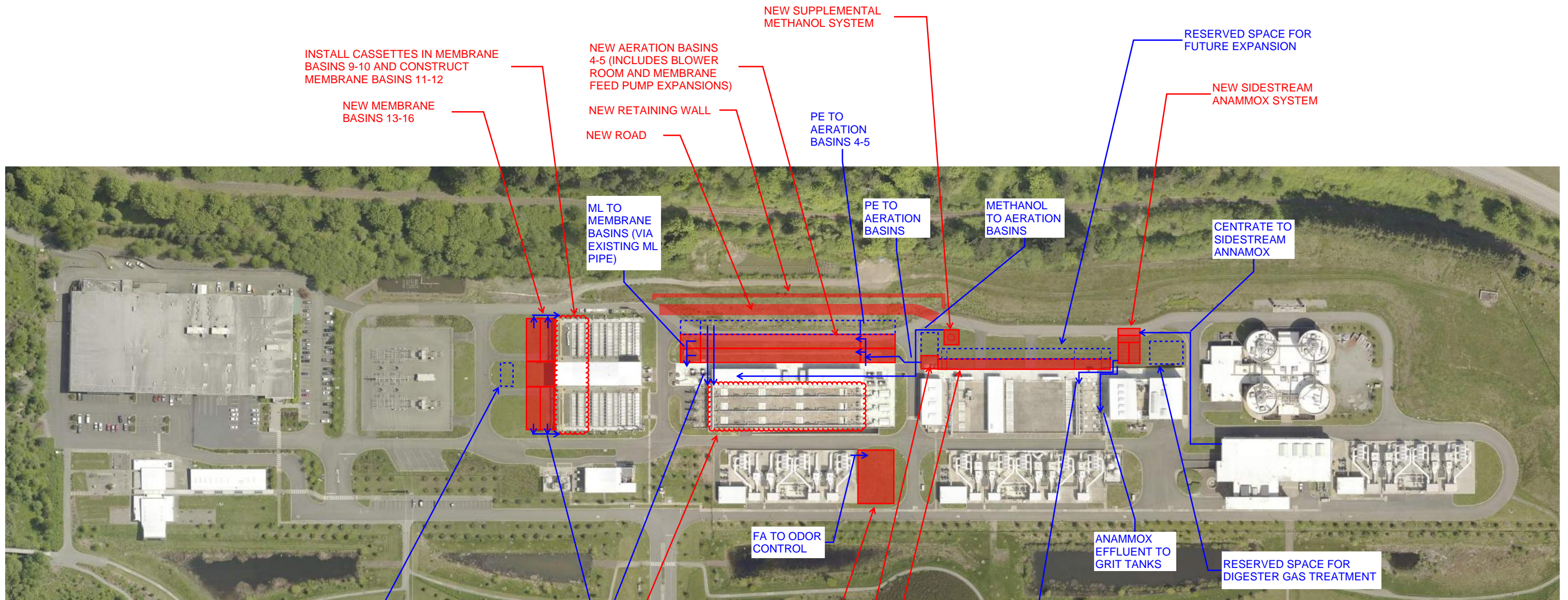
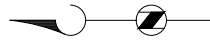

RETROFIT AERATION BASINS 1-3 FOR 4SMB:  
 -REVISE BAFFLING AND AERATION SYSTEMS FOR 4SMB  
 -REROUTE RAS TO START OF NEW FIRST AEROBIC ZONE  
 -ADD IMLR PUMPING AT END OF FIRST AEROBIC ZONE

**Implementation challenges or constructibility considerations:**  
 -Constructing aeration basins 5 and 6 will likely require extensive excavation of the east hillside and construction of a retaining wall (layout assumes that the retaining wall and road relocation would be completed during construction of aeration basin 5)  
 -More extensive retrofits to existing aeration basins and rerouting of RAS piping

**Risks:**  
 -Increased difficulty of achieving low effluent TIN concentrations in a combined effluent during winter peak flow conditions (peak flows that exceed MBR capacity are assumed to be treated with CEPT and will have higher TIN concentrations than the membrane effluent)  
 -Reduced membrane permeability during winter peak flows requires additional MBR bypass (or diversion to South Plant)

NOTE: SITE LAYOUT DESIGNED FOR CURRENT PLANT RATED CAPACITY.

BRIGHTWATER TREATMENT PLANT NITROGEN REMOVAL STUDY  
 SCENARIO 3: YEAR-ROUND NITROGEN REMOVAL, EFFLUENT TIN LIMIT OF 3 MG/L  
 ALT 3B: 4SMB/MBR + SIDESTREAM ANAMMOX



SCALE:  
 1" = 200'





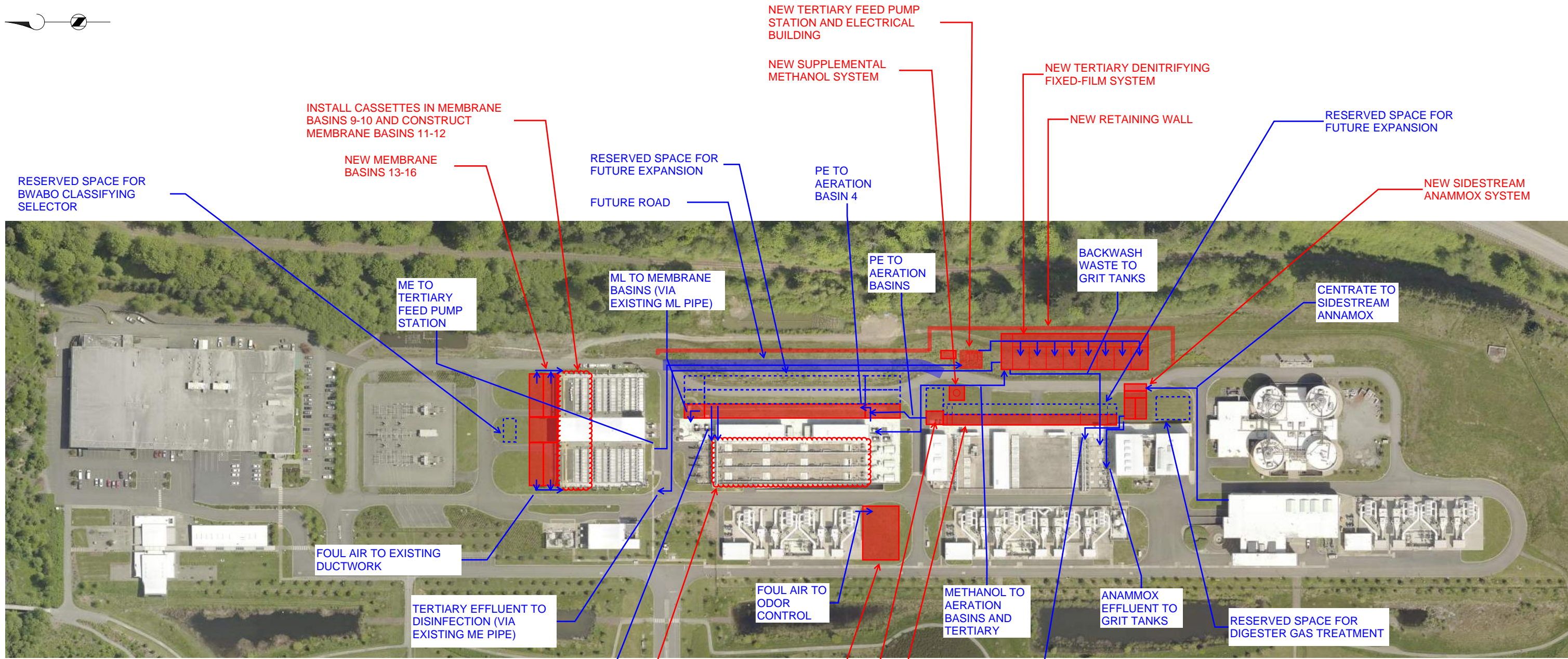
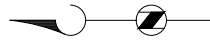

**Site layout issues/constraints:**  
 -Assumes routing of large-diameter membrane effluent piping and tertiary effluent piping can fit in area between existing aeration and membrane basins

**Implementation challenges or constructibility considerations:**  
 -Constructing the tertiary denitrifying fixed-film system will likely require extensive excavation of the east hillside and construction of a retaining wall (layout assumes that the retaining wall would be extended for full length of aeration basins to provide space for tertiary piping)

**Risks:**  
 -Increased difficulty of achieving low effluent TIN concentrations in a combined effluent during winter peak flow conditions (peak flows that exceed MBR capacity are assumed to be treated with CEPT and will have higher TIN concentrations than the tertiary effluent)  
 -Reduced membrane permeability during winter peak flows requires additional MBR bypass (or diversion to South Plant)

NOTE: SITE LAYOUT DESIGNED FOR CURRENT PLANT RATED CAPACITY.

BRIGHTWATER TREATMENT PLANT NITROGEN REMOVAL STUDY  
 SCENARIO 3: YEAR-ROUND NITROGEN REMOVAL, EFFLUENT TIN LIMIT OF 3 MG/L  
 ALT 3C: MLE/MBR + TERTIARY DENITRIFYING FIXED-FILM + SIDESTREAM ANAMMOX

SCALE:  
 1" = 200'



## **Attachment B: Greenhouse Gas Emissions Results and Literature Review of Nitrous Oxide Emission Factors**





	Alternative	Annual Averages						
		<u>1</u>	<u>2A</u>	<u>2B</u>	<u>2C</u>	<u>3A</u>	<u>3B</u>	<u>3C</u>
	Alternative Type	SND/MBR + sidestream anammox	SND/MBR + sidestream anammox	MLE/MBR + sidestream anammox	MLE/MBR + tertiary denitrifying fixed-film + sidestream anammox	SND/MBR + sidestream anammox	4SMB/MBR + sidestream anammox	MLE/MBR + tertiary denitrifying fixed-film + sidestream anammox
Operational Parameters	Power Consumption (Kwh/yr)	19,311,334	22,321,377	23,220,947	25,065,997	23,806,313	23,707,317	25,170,732
	Prod. Emissions (CO2e MT/yr)	125.5	145.1	150.9	162.9	154.7	154.1	163.6
	Supplemental Chemicals							
	Sodium Hypochlorite (gal/yr)	79,462	105,949	105,949	105,949	105,949	105,949	105,949
	Prod. Emissions (CO2e MT/yr)	223	298	298	298	298	298	298
	Transportation (CO2e MT/yr)	12	3.2	3.2	3.2	3.2	3.2	3.2
	Citric Acid (gal/yr)	9,436	12,581	12,581	12,581	12,581	12,581	12,581
	Prod. Emissions (CO2e MT/yr)	18	24	24	24	24	24	24
	Transportation (CO2e MT/yr)	1	0.38	0.38	0.38	0.38	0.38	0.38
	Alkalinity (25% Caustic) (gal/yr)	1,405,296	949,015	948,970	1,898,030	492,735	492,735	1,898,030
	Prod. Emissions (CO2e MT/yr)	3,705	2,502	2,502	5,004	1,299	1,299	5,004
	Transportation (CO2e MT/yr)	207	28.5	28.5	56.9	14.8	14.8	56.9
	Methanol (gal/yr)	-	442,301	460,654	406,063	641,439	498,203	584,000
	Prod. Emissions (CO2e MT/yr)	-	888	925	815	1,288	1,000	1,172
Transportation (CO2e MT/yr)	-	13.3	13.8	12.2	19.2	14.9	17.5	
Supplemental Chemical Subtotal (CO2e MT/yr)	4,167	3,757	3,795	6,214	2,947	2,655	6,577	
Modeled Parameters	Influent TN Load (lb/d)	-	-	-	-	-	-	-
	Secondary TN Load (Lb/d), Average	9,658	9,658	9,658	9,658	9,678	9,678	9,658
	Mainstream (AO, MLE, 4SMB) - Summer							
	Influent TN Load (lb/d)	9,292	9,292	9,292	9,292	9,292	9,292	9,292
	Effluent TN Load (lb/d)	2,586	957	1,712	4,192	957	946	4,192
	Mainstream (AO, MLE, 4SMB) - Winter							
	Influent TN Load (lb/d)	10,024	10,024	10,024	10,024	10,064	10,064	10,024
	Effluent TN Load (lb/d)	3,896	3,440	2,679	5,054	1,120	1,117	5,054
	Tertiary Treatment							
	Influent TN Load (lb/d)	-	-	-	4,623	-	-	4,623
	Effluent TN Load (lb/d)	-	-	-	2,227	-	-	1,061
Sidestream								
Influent TN Load (lb/d)	1,576	1,576	1,576	1,576	1,576	1,576	1,576	
Effluent TN Load (lb/d)	454	454	454	454	454	454	454	
Effluent TN Load (lb/d)	3,241	2,199	2,196	2,227	1,038	1,032	1,061	
Nitrous Oxide Emissions	N2O Emissions, Process (CO2e MT/Yr)	28,072	32,509	1,590	2,637	37,532	8,650	3,578
	Mainstream (AO, MLE, 4SMB) (CO2e MT/Yr) - Summer	14,269	17,735	419	282	17,735	3,805	282
	Mainstream (AO, MLE, 4SMB) (CO2e MT/Yr) - Winter	13,039	14,009	406	275	19,033	4,080	275
	Tertiary (Fixed-Film FilterS) (CO2e MT/Yr)	-	-	-	4,965	-	-	8,516
	Sidestream (CO2e MT/Yr)	765	765	765	765	765	765	765
	N2O Emissions, Effluent Nitrogen Discharge (CO2e MT/Yr)	1,120	760	758	769	359	356	367
	Total N2O Emissions, Plant (CO2e MT/Yr)	29,192	33,268	2,348	3,407	37,891	9,006	3,945
GHG Emissions	Nitrous oxide	29,192	33,268	2,348	3,407	37,891	9,006	3,945
	Energy	126	145	151	163	155	154	164
	Chemicals	4,167	3,757	3,795	6,214	2,947	2,655	6,577
	<b>Total (CO2e MT/Yr)</b>	<b>33,484</b>	<b>37,171</b>	<b>6,294</b>	<b>9,784</b>	<b>40,992</b>	<b>11,815</b>	<b>10,685</b>
GHG Emissions/ N removed, CO2e MT/MT N removed		<b>31.51</b>	<b>30.09</b>	<b>5.09</b>	<b>7.95</b>	<b>28.65</b>	<b>8.25</b>	<b>7.51</b>

GHG Emission Factor	Value	Unit	Note	Source/Reference
Methane	28	gCO2e/gCH4		IPCC (2014). Climate Change 2014 Synthesis Report Fifth Assessment Report
Nitrous Oxide	265	gCO2e/gN2O		IPCC (2014). Climate Change 2014 Synthesis Report Fifth Assessment Report
Sodium Hydroxide (Caustic Soda), 25%	0.505	kg CO2e/kg	Production emissions	EPA, 2016. LCI data - Treatment Chemicals, Construction Materials, Transportation, onsite equipment and othe processes for use in SEFA; Ecoinvent v2.2
Sodium Hydroxide (Caustic Soda), 25%	0.545	kg CO2e/kg	Production emissions, Chlor-alkali, membrane cell technique	EPA, 2016. LCI data - Treatment Chemicals, Construction Materials, Transportation, onsite equipment and othe processes for use in SEFA; Ecoinvent v2.2
Methanol, 100%	1.4	kg CO2e/kg	Production emissions	SimaProv7.10, BLE, 2010, Guideline Sustainable Biomass Production
Methanol, 100%	0.67	MT CO2e/MT feedstock	Production Emissions, Steam reforming of natural gas, Table 3.12	2006. IPCC Guidelines for National Greenhouse Gas Inventories, Chapter 3 Chemical Industry Emissions
Citric Acid, Anhydrous	0.429	kg CO2e/kg citric acid	Production emissions	<a href="https://www.canada.ca/en/environment-climate-change/services/climate-change/pricing-pollution-how-it-will-work/output-based-pricing-system/complete-text-for-proposal-regulations.html">https://www.canada.ca/en/environment-climate-change/services/climate-change/pricing-pollution-how-it-will-work/output-based-pricing-system/complete-text-for-proposal-regulations.html</a>
Citric Acid, Anhydrous	0.96	kg Co2e/kg	Production emissions	ISCC 2015 GHG emissions; Biograce v 4d, 2014
Citric Acid, 50%	0.41	kg Co2e/kg	Production emissions, Microbial	Nica, Anca & Woinaroschy, Alexandru. (2010). Environmental assessment of citric acid production. UPB Scientific Bulletin, Series B: Chemistry and Materials Science. 72.
Sodium Hypochlorite (12.5%)	0.636		Production emissions	He, C., Liu, Z. & Hodgins, M., 2013.

King County Electricity Profile	MT/MWh	g CO2e/kWh	MT/MMBtu	\$/KW
West Point	0.0089	8.90	0.003	0.0781
South Plant	0.0000	0.00	0.132	0.0758
Brightwater	0.0065	6.50	0.002	0.0781

Other Assumptions	Value	Units	Notes	Source/Reference
Sodium Hydroxide (25%) Specific Gravity	1.278			MSDS
Methanol Specific Gravity	0.7915			MSDS
Citric Acid Specific Gravity	1.24			Suez Proposal, 2019
Sodium Hypochlorite (12.5%) Specific Gravity	1.168			Suez Proposal, 2019
<b>Trucking and Transportation</b>				
Liquid transportation Capacity	6,800	Gallons		Assumption
Class 8 Tanker Truck	2.04	kg CO2e/ mile		USEPA, (2004)
Methanol Transportation, Roundtrip	100	miles		Assumption
Citric Acid Transportation, Roundtrip	100	miles		Assumption
Sodium Hydroxide Transportation, Roundtrip	100	miles		Assumption
Sodium Hypochlorite Transportation, Roundtrip	100	miles		Assumption

Configuration	N2O Emission Factors	% inf TKN emitted as N2O	% inf TN emitted as N2O	% TN Removed Emitted as N2O	IPPC Emission Factor Table 6A.5	
					Emission Factor Used % inf TN emitted as N2O	Emission Factor Used % TN Removed Emitted as N2O
BNR (IPCC, 2014)	7.0 <sup>a</sup> (Treatment), 0.005 <sup>d</sup>	-	0.764, 1.44, 1.3 <sup>7</sup> , 0.28 - 11.84 <sup>8</sup>	-	-	-
AO	-	-	-	0.128 <sup>11</sup> , 0.493 <sup>11</sup> , 0.126 <sup>12</sup>	-	0.127
BNR	-	-	0-14.6 <sup>6</sup>	-	1.6	1.6
Four-Stage Bardenpho (4SMB)	33±16 <sup>3,a</sup> , 92±47 <sup>3,a</sup>	0.60±0.29 <sup>1</sup> , 1.6±0.83 <sup>1</sup>	0.66±0.32 <sup>1</sup> , 2.9±0.15 <sup>1</sup> , 0.36 <sup>1</sup>	0.66±0.32 <sup>1</sup> , 2.9±1.5 <sup>1</sup>	0.36	0.66
MLE	6.8±3.5 <sup>1,a</sup> , 5.4±2.0 <sup>1,a</sup>	0.44 <sup>9</sup> , 0.07 <sup>9</sup>	0.07±0.04 <sup>1</sup> , 0.06±0.02 <sup>1</sup> , 0.008 <sup>2</sup> , 0.001 <sup>2</sup>	0.09±0.05 <sup>1</sup> , 0.07±0.03 <sup>1</sup>	0.07, 0.06	0.08
MBR	No Clear Literature			-	-	Assumed upstream treatment EF
Tertiary Denit Fixed Film Filters	-	-	-	1.28 <sup>13,e</sup> , 0.22 <sup>13,e</sup>	-	0.75
Sidestream Anammox	-	-	0.75 <sup>1</sup> , 1.7 <sup>1</sup> , 0.9-1.3 <sup>5</sup> , 2-9 <sup>6</sup> , 0.51 <sup>10</sup>	-	-	0.9867
Sidestream Bioaugmentation	No Clear Literature			-	-	-
Simultaneous Nitrification-Denitrification	-	-	2.7 <sup>14,c</sup> , 2.91 <sup>16,c</sup> , 7.7 <sup>15,c</sup>	3.08 <sup>16,c</sup>	-	3.08

**Reference Notation**

- 1
- 2
- 3
- 4
- 5
- 6
- 7
- 8
- 9
- 10
- 11
- 12
- 13
- 14
- 15
- 16

**Sources**

- Ahn et al., 2009  
Tumendelger et al., 2019  
Christensson et al., 2013  
Weissenbacher et al., 2012  
Strenstrom et al., 2017  
Witch et Beier, 1995  
Weissenbacher et al., 2010  
Foley et al., 2010  
Chandran, 2011  
Baresel et al., 2016  
Masuda et al., 2018  
Rodriguez-Caballero et al., 2014  
Bollon et al., 2016  
Jia et al., 2013  
Li et al., 2017  
Kong et al., 2016

**Reference Notation**

- a
- b
- c
- d
- e
- u

**Units**

- (g N2O/PE/Yr)  
(g N2O/g reduced N)  
(g N2O/g inf N)  
(g N2O-N/g eff N)  
(g N2O/g NO3 removed)  
(g-C/d)



## References

- Ahn, J. H., Kim, S., Park, H., Rahm, B., Pagilla, K., & Chandran, K. (2010). N<sub>2</sub>O emissions from activated sludge processes, 2008-2009: Results of a national monitoring survey in the united states. *Environmental Science and Technology*, 44(12), 4505–4511. <https://doi.org/10.1021/es903845y>
- Baresel, C., Andersson, S., Yang, J., & Andersen, M. H. (2016). Comparison of nitrous oxide (N<sub>2</sub>O) emissions calculations at a Swedish wastewater treatment plant based on water concentrations versus off-gas concentrations. *Advances in Climate Change Research*, 7(3), 185–191. <https://doi.org/10.1016/j.accre.2016.09.001>
- Bollon, J., Filali, A., Fayolle, Y., Guerin, S., Rocher, V., & Gillot, S. (2016). N<sub>2</sub>O emissions from full-scale nitrifying biofilters. *Water Research*, 102, 41–51. <https://doi.org/10.1016/j.watres.2016.05.091>
- Chandran, K. (2011). *Protocol for the measurement of nitrous oxide fluxes from biological wastewater treatment plants*. *Methods in Enzymology* (1st ed., Vol. 486). Elsevier Inc. <https://doi.org/10.1016/B978-0-12-381294-0.00016-X>
- Christensson, M., Ekström, S., Andersson Chan, A. Le Vaillant, E., and Lemaire, R. (2013) “Experience from startups of the first ANITA Mox plants,” *Water Sci. Technol.*, 67, 12, 2677- 2684
- Foley, J., de Haas, D., Yuan, Z., & Lant, P. (2010). Nitrous oxide generation in full-scale biological nutrient removal wastewater treatment plants. *Water Research*, 44(3), 831–844. <https://doi.org/10.1016/j.watres.2009.10.033>
- Jia, W., Liang, S., Zhang, J., Ngo, H. H., Guo, W., Yan, Y., & Zou, Y. (2013). Nitrous oxide emission in low-oxygen simultaneous nitrification and denitrification process: sources and mechanisms. *Bioresource Technology*, 136, 444–451. <https://doi.org/10.1016/j.biortech.2013.02.117>
- Kong, Q., Wang, Z. bin, Niu, P. fei, & Miao, M. sheng. (2016). Greenhouse gas emission and microbial community dynamics during simultaneous nitrification and denitrification process. *Bioresource Technology*, 210, 94–100. <https://doi.org/10.1016/j.biortech.2016.02.051>
- Li, K., Fang, F., Wang, H., Wang, C., Chen, Y., Guo, J., Wang, X., & Jiang, F. (2017). Pathways of N removal and N<sub>2</sub>O emission from a one-stage autotrophic N removal process under anaerobic conditions. *Scientific Reports*, 7(January), 1–10. <https://doi.org/10.1038/srep42072>
- Masuda, S., Sano, I., Hojo, T., Li, Y. Y., & Nishimura, O. (2018). The comparison of greenhouse gas emissions in sewage treatment plants with different treatment

processes. *Chemosphere*, 193, 581–590.  
<https://doi.org/10.1016/j.chemosphere.2017.11.018>

Rodriguez-Caballero, A., Aymerich, I., Poch, M., & Pijuan, M. (2014). Evaluation of process conditions triggering emissions of green-house gases from a biological wastewater treatment system. *Science of the Total Environment*, 493, 384–391.  
<https://doi.org/10.1016/j.scitotenv.2014.06.015>

Stenström, F. (2017). *Risk of nitrous oxide emissions and potential of bioaugmentation when treating digester supernatant via nitrification-denitrification.*

Tumendelger, A., Alshboul, Z., & Lorke, A. (2019). Methane and nitrous oxide emission from different treatment units of municipal wastewater treatment plants in Southwest Germany. *PLoS ONE*, 14(1), e0209763.  
<https://doi.org/10.1371/journal.pone.0209763>

Weissenbacher, N., Takacs, I., Murthy, S., Fuerhacker, M., & Wett, B. (2010). Gaseous Nitrogen and Carbon Emissions from a Full-Scale Deammonification Plant. *Water Environment Research*, 82(2), 169–175.  
<https://doi.org/10.2175/106143009x447867>

Wicht, H. (1996). A model for predicting nitrous oxide production during denitrification in activated sludge. In *Water Science and Technology* (Vol. 34, pp. 99–106). Pergamon Press Inc. [https://doi.org/10.1016/0273-1223\(96\)00634-8](https://doi.org/10.1016/0273-1223(96)00634-8)

## **Attachment C: Basis of Capital Cost Estimates of Alternatives**

---



Brightwater Nitrogen Removal Alternatives Cost Estimate Summary - AACEI Class 5								
Alternative	1	2A	2B	2C	3A	3B	3C	
Scenario modifications or effluent limits/targets	SND with sidestream treatment	Year-Round "N" Removal, Effluent Limit of 8mg/L			Year-Round "N" Removal, Effluent Limit of 3mg/L			
Alternative Description	SND/MBR + sidestream annamox	SND/MBR + sidestream annamox	MLE/MBR + sidestream annamox	MLE/MBR + tertiary denitrifying fixed-film + sidestream annamox	SND/MBR + sidestream annamox	4SMB/MBR + sidestream annamox	MLE/MBR + tertiary denitrifying fixed-film + sidestream annamox	
<b>DIRECT: SUBTOTAL CONSTRUCTION COSTS</b>								
Item No.	Item Description	Item Cost						
1	A - Primary Effluent (PE)	\$ -	\$ 4,287,000	\$ 4,287,000	\$ 4,287,000	\$ 4,287,000	\$ 4,287,000	\$ 4,287,000
2	B - Aeration Basins	\$ 12,061,000	\$ 12,061,000	\$ 12,622,000	\$ 12,622,000	\$ 29,831,000	\$ 20,403,000	\$ 12,622,000
3	C - Membrane Basins	\$ 16,544,000	\$ 52,325,000	\$ 52,325,000	\$ 52,325,000	\$ 52,325,000	\$ 52,325,000	\$ 52,325,000
4	D - Internal Mixed Liquor Return (IMLR) Pumping	\$ 849,000	\$ 7,958,000	\$ 7,958,000	\$ 5,055,000	\$ 11,354,000	\$ 14,312,000	\$ 5,055,000
6	F - Sidestream Anammox	\$ 14,689,000	\$ 14,689,000	\$ 14,689,000	\$ 14,689,000	\$ 14,689,000	\$ 14,689,000	\$ 14,689,000
7	G - Supplemental Methanol System	\$ -	\$ 1,795,000	\$ 1,795,000	\$ 1,795,000	\$ 3,590,000	\$ 1,795,000	\$ 1,795,000
9	I - Aeration Blowers	\$ -	\$ 3,844,000	\$ 3,844,000	\$ 3,844,000	\$ 7,605,000	\$ 12,814,000	\$ 3,844,000
10	J - Aeration Basin Mixers for Anoxic Zones	\$ 127,000	\$ 127,000	\$ 1,143,000	\$ 1,143,000	\$ 381,000	\$ 2,341,000	\$ 1,143,000
12	L - Tertiary Pumps	\$ -	\$ -	\$ -	\$ 7,328,000	\$ -	\$ -	\$ 7,328,000
13	M - Tertiary Fixed Film System	\$ -	\$ -	\$ -	\$ 32,058,000	\$ -	\$ -	\$ 40,423,000
14	N - Aeration / MBR Odor Control	\$ 235,000	\$ 8,192,000	\$ 8,192,000	\$ 8,192,000	\$ 8,263,000	\$ 8,228,000	\$ 8,192,000
15	O - Primary Clarifier / Aerated Grit Tank	\$ -	\$ 7,744,000	\$ 7,744,000	\$ 7,744,000	\$ 7,744,000	\$ 7,744,000	\$ 7,744,000
16	P - Miscellaneous Scope	\$ 578,000	\$ 2,008,000	\$ 2,008,000	\$ 14,118,000	\$ 6,904,000	\$ 6,676,000	\$ 14,118,000
	<b>Subtotal Construction Costs</b>	<b>\$ 45,083,000</b>	<b>\$ 115,030,000</b>	<b>\$ 116,607,000</b>	<b>\$ 165,200,000</b>	<b>\$ 146,973,000</b>	<b>\$ 145,614,000</b>	<b>\$ 173,565,000</b>
	Allowance for Indeterminates (Design Allowance)	\$ 11,270,750	\$ 28,757,500	\$ 29,151,750	\$ 41,300,000	\$ 36,743,250	\$ 36,403,500	\$ 43,391,250
	Street Use Permit	\$ -	\$ -	\$ -	\$ -	\$ -	\$ -	\$ -
	<b>ESTIMATED PROBABLE COST OF CONSTRUCTION BID</b>	<b>\$ 56,353,750</b>	<b>\$ 143,787,500</b>	<b>\$ 145,758,750</b>	<b>\$ 206,500,000</b>	<b>\$ 183,716,250</b>	<b>\$ 182,017,500</b>	<b>\$ 216,956,250</b>
<b>DIRECT: SUBTOTAL ADDITIONAL CONSTRUCTION COSTS</b>								
	Mitigation Construction Contracts	\$ -	\$ -	\$ -	\$ -	\$ -	\$ -	\$ -
	Construction Change Order Allowance	\$ 5,635,375	\$ 14,378,750	\$ 14,575,875	\$ 20,650,000	\$ 18,371,625	\$ 18,201,750	\$ 21,695,625
	Material Pricing Uncertainty Allowance	\$ -	\$ -	\$ -	\$ -	\$ -	\$ -	\$ -
	<b>Subtotal Primary Construction Amount</b>	<b>\$ 61,989,125</b>	<b>\$ 158,166,250</b>	<b>\$ 160,334,625</b>	<b>\$ 227,150,000</b>	<b>\$ 202,087,875</b>	<b>\$ 200,219,250</b>	<b>\$ 238,651,875</b>
	Construction Sales Tax	\$ 6,260,902	\$ 15,974,791	\$ 16,193,797	\$ 22,942,150	\$ 20,410,875	\$ 20,222,144	\$ 24,103,839
	Owner Furnished Equipment	\$ -	\$ -	\$ -	\$ -	\$ -	\$ -	\$ -
	Outside Agency Construction	\$ -	\$ -	\$ -	\$ -	\$ -	\$ -	\$ -
	<b>Subtotal KC Contribution to Construction</b>	<b>\$ 68,250,027</b>	<b>\$ 174,141,041</b>	<b>\$ 176,528,422</b>	<b>\$ 250,092,150</b>	<b>\$ 222,498,750</b>	<b>\$ 220,441,394</b>	<b>\$ 262,755,714</b>
<b>DIRECT: SUBTOTAL OTHER CAPITAL CHARGES</b>								
	KC/WTD Direct Implementation	\$ -	\$ -	\$ -	\$ -	\$ -	\$ -	\$ -
	Misc. Capital Costs	\$ 123,978	\$ 316,333	\$ 320,669	\$ 454,300	\$ 404,176	\$ 400,439	\$ 477,304
	<b>TOTAL DIRECT CONSTRUCTION COSTS</b>	<b>\$ 68,374,000</b>	<b>\$ 174,457,000</b>	<b>\$ 176,849,000</b>	<b>\$ 250,546,000</b>	<b>\$ 222,903,000</b>	<b>\$ 220,842,000</b>	<b>\$ 263,233,000</b>
<b>INDIRECT: NON-CONSTRUCTION COSTS</b>								
	Design and Construction Consulting	\$ 15,693,431	\$ 43,963,910	\$ 44,459,978	\$ 59,245,291	\$ 53,802,750	\$ 53,392,379	\$ 61,707,379
	Other Consulting Services	\$ -	\$ -	\$ -	\$ -	\$ -	\$ -	\$ -
	Permitting & Other Agency Support	\$ 309,946	\$ 790,831	\$ 801,673	\$ 1,135,750	\$ 1,778,373	\$ 1,761,929	\$ 2,100,137
	Right-of-Way	\$ -	\$ -	\$ -	\$ -	\$ -	\$ -	\$ -
	Misc. Service & Materials	\$ 1,115,804	\$ 2,846,993	\$ 2,886,023	\$ 4,088,700	\$ 3,637,582	\$ 3,603,947	\$ 4,295,734
	Non-WTD Support	\$ 402,929	\$ 1,028,081	\$ 1,042,175	\$ 1,476,475	\$ 1,313,571	\$ 1,301,425	\$ 1,551,237
	WTD Staff Labor	\$ 9,416,152	\$ 22,303,088	\$ 22,577,780	\$ 30,903,884	\$ 27,809,252	\$ 27,577,261	\$ 32,314,347
	<b>Subtotal Non-Construction Costs</b>	<b>\$ 26,938,262</b>	<b>\$ 70,932,903</b>	<b>\$ 71,767,630</b>	<b>\$ 96,850,100</b>	<b>\$ 88,341,528</b>	<b>\$ 87,636,941</b>	<b>\$ 101,968,833</b>
	Project Contingency	\$ 28,776,610	\$ 74,088,121	\$ 75,062,243	\$ 104,885,655	\$ 93,969,562	\$ 93,134,564	\$ 110,260,062
	Initiatives	\$ 1,122,571	\$ 2,878,556	\$ 2,917,124	\$ 4,101,400	\$ 3,659,192	\$ 3,626,087	\$ 4,305,938
	<b>TOTAL INDIRECT NON-CONSTRUCTION COSTS</b>	<b>\$ 56,837,000</b>	<b>\$ 147,900,000</b>	<b>\$ 149,747,000</b>	<b>\$ 205,837,000</b>	<b>\$ 185,970,000</b>	<b>\$ 184,398,000</b>	<b>\$ 216,535,000</b>
	<b>TOTAL PROJECT COST</b>	<b>\$ 125,210,000</b>	<b>\$ 322,360,000</b>	<b>\$ 326,600,000</b>	<b>\$ 456,380,000</b>	<b>\$ 408,870,000</b>	<b>\$ 405,240,000</b>	<b>\$ 479,770,000</b>
	<b>TOTAL PROJECT COST - Low End (-50%)</b>	<b>\$ 62,610,000</b>	<b>\$ 161,180,000</b>	<b>\$ 163,300,000</b>	<b>\$ 228,190,000</b>	<b>\$ 204,440,000</b>	<b>\$ 202,620,000</b>	<b>\$ 239,890,000</b>
	<b>TOTAL PROJECT COST - High End (+300%)</b>	<b>\$ 500,840,000</b>	<b>\$ 1,289,440,000</b>	<b>\$ 1,306,400,000</b>	<b>\$ 1,825,520,000</b>	<b>\$ 1,635,480,000</b>	<b>\$ 1,620,960,000</b>	<b>\$ 1,919,080,000</b>



# King County

Department of Natural Resources and Parks  
Wastewater Treatment Division

## Project Planning and Delivery Section

### BASIS OF ESTIMATE

---

Project Name	<b>Brightwater Treatment Plant Nitrogen Removal - Alternative 1</b>
Project Number	
Date Prepared	April 29, 2020
Requested by	Tiffany Knapp, King County WTD
Prepared by	Douglas W. Leo, CCP, CEP, FRICS, FAACE Hon. Life, (VMS, Inc.)
Estimate Classification	WTD Class 5
Estimate Purpose	King County Class 5 Concept Screening
Estimate ID (Version)	6
Project Manager	Eron Jacobson, King County WTD
Project Control Engineer	
Cc or Distribution List	

*Note that the accuracy of the associated cost estimate is dependent upon the various underlying assumptions, inclusions, and exclusions described herein. Actual project costs may differ and can be significantly affected by factors such as changes in the external environment, the manner in which the project is executed and controlled, and other factors that may impact the estimate basis or otherwise affect the project. Estimate accuracy ranges are only assessments based upon the cost estimating methods and data employed in preparing the estimate and are not a guarantee of actual project costs.*

## BASIS OF ESTIMATE

Project Name	<b>Brightwater Treatment Plant Nitrogen Removal - Alternative 1</b>		
Project Number:		Date:	April 29, 2020

### 1.0 Purpose

---

The purpose of this estimate is to provide cost information to support King County's Brightwater Treatment Plant (BWTP) Flows and Loading Alternative Evaluation for the Nitrogen Removal Project. A series of alternatives have been developed for project evaluation to determine the best engineering and project cost solution.

This estimate was prepared to establish a King County Wastewater Treatment Division (WTD) pre-Class 5 conceptual cost estimate to provide order of magnitude cost to support WTD's capital project identification and budgeting process for Total Project Costs. The WTD pre-Class 5 estimate provides similar documentation to that of an AACE International Class 5 estimate. The range of anticipated project costs, per WTD estimating guidance, is -50% / +300%. The range of uncertainty is beyond that for a typical Class 5 estimate due to the scope being proximally defined with today's relative solutions and technologies to resolving the identified needs; when the projects move forward into capital delivery over the longer term, it is anticipated that many differences and changes may arise as the known and defined engineering solutions are developed.

Douglas Leo of Value Management Strategies, Inc. (VMS) prepared this Basis of Estimate in coordination with King County WTD, the Brown and Caldwell Engineers team, and the VMS estimating team after receiving scope information from WTD in December 2019 thru April 2020. This Basis of Estimate reflects VMS's best understanding of the estimating process for this project, as explained by King County WTD and Brown and Caldwell.

### 2.0 Project Scope Definition

---

This estimate includes all investigation, administration/owners' costs, engineering and design, purchases, fabrications, installations, process certifications, permitting, community impacts, and miscellaneous costs not specifically excluded elsewhere in this document.

Comprehensive Total Field Costs are generated from historical allowances, sources such as WTD estimating tools, historical costs, and RS Means/VMS estimating databases. All supporting indirect costs were generated from the WTD PRISM historical database. All costs included in the estimate reflect the best understanding of requirements as they existed at the time this estimate was prepared.

The scope of BWTP Flows and Loading Alternative 1 is to provide Simultaneous Nitrification-Denitrification (SND) with sidestream anammox treatment. The scope was developed to a Conceptual Design level adequate to assess operations and maintenance issues, energy impacts, permitting and code compliance issues, constructability, estimated costs, and implementation schedule.

The Project Estimate was prepared utilizing the following Work Breakdown Structure (WBS) in order to provide clarity and transparency to the estimated costs. The scope as identified for the alternative is described below in accordance with the WBS. Details are based on the known and defined scope in the design documents provided. See section 3.0 for a detailed list of Design Documents.

- A. Primary Effluent (PE)
  - *Not included in the scope for this alternative.*
- B. Aeration Basins
  - General
    - New Aeration Basin – purchase and install
    - Baffle Wall in New Aeration Basin
    - Interior Basin Piping

## BASIS OF ESTIMATE

Project Name	<b>Brightwater Treatment Plant Nitrogen Removal - Alternative 1</b>		
Project Number:		Date:	April 29, 2020

- C. Membrane Basins
  - Membrane System (New Cells) – purchase and install
  - Membrane System (Retrofit Cells)
  - Concrete Membrane Vault Basins
- D. Internal Mixed Liquor Return (IMLR) Pumping
  - IMLR Pump Equipment – purchase and install
  - 20" CS Piping
- E. Return Activated Sludge (RAS) Pump
  - *Not included in the scope for this alternative*
- F. Sidestream Anammox
  - Sidestream Anammox – purchase and install
  - Pumps / Skimmer / Chains / Flight for Sedimentation Tank / Mixers – purchase and install
  - Centrate EQ Tank (60K gal) – purchase and install
  - Centrate Sedimentation Tank (60K gal) – purchase and install
  - Anammox Reactor Tanks (118.5K gal) – purchase and install
- G. Supplemental Methanol System
  - *Not included in the scope for this alternative*
- H. Supplemental Alkalinity System
  - *Not included in the scope for this alternative*
- I. Aeration Blowers
  - *Not included in the scope for this alternative*
- J. Aeration Basin Mixers for Anoxic Zones
  - Aeration Basin Mixers – purchase and install
- K. Sidestream Bioaugmentation
  - *Not included in the scope for this alternative*
- L. Tertiary Pumps
  - *Not included in the scope for this alternative*
- M. Tertiary Fixed Film System
  - *Not included in the scope for this alternative*
- N. Aeration / MBR Odor Control
  - Foul Air Ductwork – Aeration Basin
  - Foul Air Ductwork - Sidestream
- O. Primary Clarifier / Aerated Grit Tank
  - *Not included in the scope for this alternative*
- P. Miscellaneous Scope
  - Centrate to Sidestream Anammox – purchase and install
  - Anammox Effluent to Grit Tank
  - 36" and 72" CS ML Pipe from Aeration Basin to Membrane Basin



## BASIS OF ESTIMATE

Project Name	<b>Brightwater Treatment Plant Nitrogen Removal - Alternative 1</b>		
Project Number:		Date:	April 29, 2020

### 3.0 Design Basis

---

This is an AACE International Class 5 estimate with all required documentation. The estimate is based on engineering deliverables, scoping documentation, discussions with the project team, and all supporting information and documentation provided in December 2019 thru April 2020.

Engineering conceptual scope was provided in the following estimating deliverables. These are the most complete scoping documents that were available to the estimating provider.

Engineering and Estimating Deliverables provided include:

- Brown and Caldwell Layout, Brightwater Nitrogen Removal Study, 7ea. Alternative Marked Up Sketches, (Alt.1/2A/2B/2C/3A/3B/3C), undated
- Brown and Caldwell, Tertiary Feed Pump Station Wetwell layout, Alt. 2C/3C, undated.
- Brown and Caldwell, BW Nitrogen Removal Alt. Cost Estimating Alt1/2A/2B/2C/3A/3B/3C, v0, undated
- KC, WPTP, Aeration Basin Plan View, dated: 01.18.2010
- KC, WPTP, Aeration Basin 2ea Sketch SND Alt.1, dated: 09.05.2013
- KC, WPTP, Aeration Basin 2ea Sketch SND Alt. 2A/3A, dated: 09.05.2013
- KC, WPTP, Aeration Basin 2ea Sketch MLE Alt. 2B/2C/3C, dated: 09.05.2013
- KC, WPTP, Aeration Basin 2ea Sketch 4SMB Alt. 3B, dated: 09.05.2013
- Estimation of MBR as final construction cost of Brightwater, dated: 12.11.2019
- Membrane Tanks 9 and 10 Estimate, Eric Benton, dated: 01.05.2018
- New Aeration Basin, East blower Room and Anoxic Basin Estimate, Eric Benton, dated: 02.06.2018
- Veolia, Biostyr Example Drawings 5ea, dated: 02.27.2019
- BW – YP – SD Model All Yard Piping, undated PDF
- KC WTD, BWTP Vol.11, General Sheets and Legends, Record Drawings, dated: Nov. 2012
- KC WTD, BWTP Vol. 12, Process and Instrumentation Diagrams, dated: 2013
- KC WTD, BWTP Vol. 22, Mechanical Area 510 Aeration Basins, dated: 2013
- KC WTD, BWTP Vol. 22, Structural Area 510 Aeration Basins, dated: 2013
- KC WTD, BWTP Vol. 23, Mechanical Area 520 Membrane Basins, dated: 2013
- KC WTD, BWTP Vol. 23, Structural Area 520 Membrane Basins, dated: 2013
- KC WTD. BWTP Vol. 16 Headworks Package
- KC WTD. BWTP Vol. 17 Grit Package
- KC WTD. BWTP Vol. 18 Headworks Truck Loadout Package
- KC WTD. BWTP Vol. 19 Primaries Package
- KC WTD. BWTP Vol. 20 PE Screens Package
- KC WTD. BWTP Vol. 21 HW Prim Odor Control Package
- KC WTD. BWTP Vol. 24 Aer MBR Odor Control Package
- KC WTD. BWTP Vol. 25 Disinfection Package
- KC WTD. BWTP Vol. 26 Chem Storage Package
- KC WTD. BWTP Vol. 27 Solids Bldg. Package
- Brightwater Anammox Cap Cost Assumptions
- KC WTD, Aeration Basin #4 RAS Anoxic Basin and Side Stream BOE, dated: 02.18.2018
- KC WTD, BW Membrane Cassettes 9 and 10 BOE, dated: 02.09.2018
- Brightwater Nitrogen Removal Alternatives – Cost Estimating Assumptions V2, undated.

Equipment Quotes:

## BASIS OF ESTIMATE

Project Name	<b>Brightwater Treatment Plant Nitrogen Removal - Alternative 1</b>		
Project Number:		Date:	April 29, 2020

- Next Turbo Budget Quote, Aeration Blowers, dated: 10.25.2019
- Suez Budget Quote, MBR, dated: 10.21.2019
- Ovivo Budget Quote, Sidestream Anammox, dated: 12.18.2019
- Biostyr Budget Quote, Tertiary, dated: 12.19.2019
- Fairbanks Quotation Curve, IMLR Pumps, undated.
- Fairbanks Quotation Curve, Tertiary Feed Pumps, undated.

### 4.0 Planning Basis

---

The following planning basis assumptions were made for the project estimate:

- No project construction plan is in place at this time.
- The assumed execution strategy is a standard workweek with limited overtime.
- No unusual site conditions have been considered as part of this estimate.
- Adequate available power exists at the site.

### 5.0 Cost Basis

---

- All allied and indirect project costs (allowances for indeterminates, change order allowance, engineering, permitting, WTD staffing, etc.) have been estimated using WTD's PRISM cost model which is baselined to historical project costs.
- The estimate was performed based on drawings, sketches, and project information provided by King County and Brown and Caldwell Engineers.
- WTD is using a PRISM cost model dated January 26, 2017. All Allied and indirect project costs have been estimated using the new WTD PRISM cost model baselined to historical project costs.
- Additional technical project complexity factors for WTD indirect project costs have been introduced and incorporated into project allied costs to allow for development of an additional WTD indirect cost allowance, based upon the unique characteristics of the project.
- Equipment factors were developed utilizing historical data which accounts for specific install of the identified equipment within a normal battery limit. Specific scope relative to this project was used in the equipment factor determination. Factors for each specific type of equipment reflect the different complexity of the installation. Engineering supplied equipment costs were multiplied by the factors in order to estimate direct construction cost for the purchase and install of the equipment.
- Estimated costs incorporate prevailing King County wage rates.
- All costs were estimated in 1<sup>st</sup> Quarter 2020 dollars.

## BASIS OF ESTIMATE

Project Name	<b>Brightwater Treatment Plant Nitrogen Removal - Alternative 1</b>		
Project Number:		Date:	April 29, 2020

### 6.0 Allowances

---

The level and types of allowances used in the estimate is as follows (common percentages for each alternative are shown and any estimate-specific differences are indicated):

- Sales Tax was included as 10.1% applied to the base construction cost, including the design and change order contingencies.
- A 25% Allowance for Indeterminates (AFI) is applied to the base construction cost. The AFI is an allowance that accounts for the cost of known but undefined requirements necessary for a complete and workable project. The AFI accounts for elements that are not explicitly shown in the project documents to be further defined as part of the design development and project delivery process. The AFI is carried at 25% at conceptual design, based on the WTD project delivery process.
- Allowance of 10% for potential construction change orders.
- Allowance of 0.2% of the primary construction amount for miscellaneous direct capital costs.
- Allowance of 0.88% of the primary construction amount for permitting and other agency support.
- Allowance of 1.8% of the primary construction amount for miscellaneous services and material.
- Allowance of 0.65% of the primary construction amount for Non-WTD Support.
- Allowance of 1.0% of the primary construction amount for art initiatives.
- Allowance of 0.5% of the total project cost for sustainability.
- Allowance for application of total project contingency (see *Contingency* section below).
- Allowance of 0% was included for Escalation as the estimate is produced in current year (2020) dollars.
- Allowance of 14.94% of the primary construction amount for Engineering Services.
- Allowance of 10.37% of the primary construction amount for Construction Management Support
- Allowance of 13.77% of the primary construction amount for WTD staff labor and burden.
- No Escalation has been included.
- Additional estimating allowances for WTD indirect costs of approximately \$2.81 million have been included in the Total Project Cost estimate by using a moderate degree of complexity rating for Construction Management, Operations Support, Project Management. Complexity factors were calibrated based on comments received from King County on March 04, 2020.
  - An allowance of \$1.48 million for Design and Construction Consulting
  - An allowance of \$0 million for Permitting & Other Agency Support
  - An allowance of \$1.33 million for WTD Staff Labor

## BASIS OF ESTIMATE

Project Name	<b>Brightwater Treatment Plant Nitrogen Removal - Alternative 1</b>		
Project Number:		Date:	April 29, 2020

### 7.0 Assumptions

---

Any other assumptions made by the estimator but not documented elsewhere in the estimate basis are included in this section.

- All costs included in the estimate reflect the best understanding of requirements as they existed at the time the estimates were prepared. Any modifications to the present scope and/or location of the project site may have substantial cost and schedule impacts.
- The engineering design will be performed by an external consultant engineer.
- Construction management will not be performed “in-house” by WTD. It will be performed by an external consultant construction manager.
- The project will generally align with the WTD PRISM cost model for Treatment projects.
- All work will always be performed utilizing safe work methods.
- Work will be sequenced to minimize standard process, service, and community interruptions. However, no costs are included to address sequencing necessary to keep the plant operational during construction.
- No costs are included for any new facilities that would be required, beyond the scope of this project to replace any lost capacity to the Brightwater Treatment Plant.
- It is assumed that the best improvement solution is included in the project scope(s).
- There will be some degree of productivity loss due to the site location. Some degree of productivity loss is included in the estimated costs. Any unusual site conditions are not accounted for in this estimate.
- Any additional work discovered during project implementation would need to be either a supplemental approval of added scope or be approved as an additional project.
- This project will be engineered to meet Washington State area seismic requirements.
- A degree of minimal cost rounding will occur during the normal estimating process.
- No allowance is included for Material Pricing Uncertainty.
- Power is readily available in the general area of this project. No new power sources are included in the scope of this project.
- It is assumed that some general material contamination is present. The estimate covers minimal cost of removal wherever the contamination is disturbed during construction. This cost is covered in productivity rates utilized in the estimate.

### 8.0 Exclusions

---

All potential items of cost which might be associated with the project but for which no costs have been included are listed below:

- No asbestos removal costs are included.
- No estimated costs are included for any potential delays due to interferences.
- No costs are included for utility relocations.

## BASIS OF ESTIMATE

Project Name	<b>Brightwater Treatment Plant Nitrogen Removal - Alternative 1</b>		
Project Number:		Date:	April 29, 2020

- No costs are included for temporary construction easements.
- No costs are included for street use or street improvement permits.
- No costs are included for additional scope beyond that as detailed in the current scope of work.

### 9.0 Exceptions

---

This estimate is classified as a King County Wastewater Treatment Division Class 5 estimate based on an AACE International Class 5 estimate, with no exceptions per the King County WTD project process, for the scope as known at the time of the estimate preparation.

### 10.0 Risks (Threats and Opportunities)

---

At the time of estimate preparation, a formal risk analysis session had not been conducted. General potential risks are listed below.

- There is a risk that additional scope, technology advances or major deviation from the suggested project scope will adversely impact cost and schedule.
- Future unknown or changing site conditions present a risk around productivities, schedule, and costs.
- More stringent or completely new regulations, usage fees, permitting, or environmental impacts may result in risks that could adversely impact cost and schedule.
- Potential complex construction and constructability issues could arise during construction, resulting in major design/construction changes.
- The space constraints could significantly impact assumed productivities and crew sizes identified for the estimated concept, resulting in increased costs due to loss of production.
- The scheduled timing of project execution will greatly impact the bottom-line costs. There is risk related to labor availability and fluctuating commodity and equipment pricing in the timeframe between this early conceptual estimate and the actual execution of the project. Rising costs due to inflation, escalation and competing major worldwide projects pose the possibility of noticeable project cost and schedule increases.
- Weather conditions and emergency service interruptions present the possibility of negative schedule and cost impacts.
- Any possible coordination with other agencies could result in potential impacts on costs, schedule and Project Definition process.
- There is a risk that stakeholders could oppose the proposed design or prefer a different approach or site to be selected, resulting in schedule delays and a higher cost alternative.

## **BASIS OF ESTIMATE**

Project Name	<b>Brightwater Treatment Plant Nitrogen Removal - Alternative 1</b>		
Project Number:		Date:	April 29, 2020

### **11.0 Contingency**

---

Contingency is a cost element of the estimate used to cover uncertainties and unforeseeable elements of cost within the defined project scope. Contingency covers inadequacies in project scope definition, estimating methods, and estimating data. Contingency specifically excludes changes in project scope, and unforeseen major events such as earthquakes, prolonged labor strikes, etc.

A 30% Project Contingency was added to the base estimate of Total Project Costs (direct and indirect) as a result of the project estimating process and in accordance with the King County WTD project delivery process.

The estimating analysis resulted in a project contingency of approximately \$28.78 million (US\$).

The total project cost at a 50% confidence level (P50) is typically used for funding and baselining of a project at this stage and level of engineering and project development. The P50 confidence level suggests that there is a 50% cumulative probability of project cost under-run (or 50% probability of exceedance) at this dollar amount for the presently defined and known project scope.

### **12.0 Management Reserve**

---

No allocation of costs was included in this estimate for Management Reserves.

Contingency is not intended to cover the costs for changes in project scope. If the project needs to provide an allowance for anticipated changes in scope or to cover the costs for items that may be required but have not yet been specifically identified as being included in the current project scope, then that amount of cost should be identified here.

### **13.0 Reconciliation**

---

Reconciliation was not conducted at this time.

### **14.0 Benchmarking**

---

All included Allied Costs as supplied by the PRISM historical database have been benchmarked against a similar portfolio of recently completed projects.

### **15.0 Estimate Quality Assurance Plan**

---

No reviews of total project costs have been conducted outside the reviews conducted within Brown and Caldwell and VMS estimating team. It is anticipated that upon completion of this estimate, reviews will happen between the estimate provider and WTD.

### **16.0 Attachments**

---

#### **Attachment: Estimate Deliverables**

Engineering and Estimating Deliverables provided include:

- Brown and Caldwell Layout, Brightwater Nitrogen Removal Study, 7ea. Alternative Marked Up Sketches, (Alt. 1/2A/2B/2C/3A/3B/3C), undated
- Brown and Caldwell, Tertiary Feed Pump Station Wetwell layout, Alt. 2C/3C, undated.

## BASIS OF ESTIMATE

Project Name	<b>Brightwater Treatment Plant Nitrogen Removal - Alternative 1</b>		
Project Number:		Date:	April 29, 2020

- Brown and Caldwell, BW Nitrogen Removal Alt. Cost Estimating Alt1/2A/2B/2C/3A/3B/3C, v0, undated
- KC, WPTP, Aeration Basin Plan View, dated: 01.18.2010
- KC, WPTP, Aeration Basin 2ea Sketch SND Alt.1, dated: 09.05.2013
- KC, WPTP, Aeration Basin 2ea Sketch SND Alt. 2A/3A, dated: 09.05.2013
- KC, WPTP, Aeration Basin 2ea Sketch MLE Alt. 2B/2C/3C, dated: 09.05.2013
- KC, WPTP, Aeration Basin 2ea Sketch 4SMB Alt. 3B, dated: 09.05.2013
- Estimation of MBR as final construction cost of Brightwater, dated: 12.11.2019
- Membrane Tanks 9 and 10 Estimate, Eric Benton, dated: 01.05.2018
- New Aeration Basin, East blower Room and Anoxic Basin Estimate, Eric Benton, dated: 02.06.2018
- Veolia, Biostyr Example Drawings 5ea, dated: 02.27.2019
- BW – YP – SD Model All Yard Piping, undated PDF
- KC WTD, BWTP Vol.11, General Sheets and Legends, Record Drawings, dated: Nov. 2012
- KC WTD, BWTP Vol. 12, Process and Instrumentation Diagrams, dated: 2013
- KC WTD, BWTP Vol. 22, Mechanical Area 510 Aeration Basins, dated: 2013
- KC WTD, BWTP Vol. 22, Structural Area 510 Aeration Basins, dated: 2013
- KC WTD, BWTP Vol. 23, Mechanical Area 520 Membrane Basins, dated: 2013
- KC WTD, BWTP Vol. 23, Structural Area 520 Membrane Basins, dated: 2013
- KC WTD. BWTP Vol. 16 Headworks Package
- KC WTD. BWTP Vol. 17 Grit Package
- KC WTD. BWTP Vol. 18 Headworks Truck Loadout Package
- KC WTD. BWTP Vol. 19 Primaries Package
- KC WTD. BWTP Vol. 20 PE Screens Package
- KC WTD. BWTP Vol. 21 HW Prim Odor Control Package
- KC WTD. BWTP Vol. 24 Aer MBR Odor Control Package
- KC WTD. BWTP Vol. 25 Disinfection Package
- KC WTD. BWTP Vol. 26 Chem Storage Package
- KC WTD. BWTP Vol. 27 Solids Bldg. Package
- Brightwater Anammox Cap Cost Assumptions
- KC WTD, Aeration Basin #4 RAS Anoxic Basin and Side Stream BOE, dated: 02.18.2018
- KC WTD, BW Membrane Cassettes 9 and 10 BOE, dated: 02.09.2018
- Brightwater Nitrogen Removal Alternatives – Cost Estimating Assumptions V2, undated.

### Equipment Quotes:

- Next Turbo Budget Quote, Aeration Blowers, dated: 10.25.2019
- Suez Budget Quote, MBR, dated: 10.21.2019
- Ovivo Budget Quote, Sidestream Anammox, dated: 12.18.2019
- Biostyr Budget Quote, Tertiary, dated: 12.19.2019
- Fairbanks Quotation Curve, IMLR Pumps, undated.
- Fairbanks Quotation Curve, Tertiary Feed Pumps, undated.





# King County

Department of Natural Resources and Parks  
Wastewater Treatment Division

## Project Planning and Delivery Section

### BASIS OF ESTIMATE

---

Project Name	<b>Brightwater Treatment Plant Nitrogen Removal - Alternative 2A</b>
Project Number	
Date Prepared	April 28, 2020
Requested by	Tiffany Knapp, King County WTD
Prepared by	Douglas W. Leo, CCP, CEP, FRICS, FAACE Hon. Life, (VMS, Inc.)
Estimate Classification	WTD Class 5
Estimate Purpose	King County Class 5 Concept Screening
Estimate ID (Version)	5
Project Manager	Eron Jacobson, King County WTD
Project Control Engineer	
Cc or Distribution List	

*Note that the accuracy of the associated cost estimate is dependent upon the various underlying assumptions, inclusions, and exclusions described herein. Actual project costs may differ and can be significantly affected by factors such as changes in the external environment, the manner in which the project is executed and controlled, and other factors that may impact the estimate basis or otherwise affect the project. Estimate accuracy ranges are only assessments based upon the cost estimating methods and data employed in preparing the estimate and are not a guarantee of actual project costs.*

## **BASIS OF ESTIMATE**

Project Name	<b>Brightwater Treatment Plant Nitrogen Removal - Alternative 2A</b>		
Project Number:		Date:	April 28, 2020

### **1.0 Purpose**

---

The purpose of this estimate is to provide cost information to support King County's Brightwater Treatment Plant (BWTP) Flows and Loading Alternative Evaluation for the Nitrogen Removal Project. A series of alternatives have been developed for project evaluation to determine the best engineering and project cost solution.

This estimate was prepared to establish a King County Wastewater Treatment Division (WTD) pre-Class 5 conceptual cost estimate to provide order of magnitude cost to support WTD's capital project identification and budgeting process for Total Project Costs. The WTD pre-Class 5 estimate provides similar documentation to that of an AACE International Class 5 estimate. The range of anticipated project costs, per WTD estimating guidance, is -50% / +300%. The range of uncertainty is beyond that for a typical Class 5 estimate due to the scope being proximally defined with today's relative solutions and technologies to resolving the identified needs; when the projects move forward into capital delivery over the longer term, it is anticipated that many differences and changes may arise as the known and defined engineering solutions are developed.

Douglas Leo of Value Management Strategies, Inc. (VMS) prepared this Basis of Estimate in coordination with King County WTD, the Brown and Caldwell Engineers team, and the VMS estimating team after receiving scope information from WTD in December 2019 thru April 2020. This Basis of Estimate reflects VMS's best understanding of the estimating process for this project, as explained by King County WTD and Brown and Caldwell.

### **2.0 Project Scope Definition**

---

This estimate includes all investigation, administration/owners' costs, engineering and design, purchases, fabrications, installations, process certifications, permitting, community impacts, and miscellaneous costs not specifically excluded elsewhere in this document.

Comprehensive Total Field Costs are generated from historical allowances, sources such as WTD estimating tools, historical costs, and RS Means/VMS estimating databases. All supporting indirect costs were generated from the WTD PRISM historical database. All costs included in the estimate reflect the best understanding of requirements as they existed at the time this estimate was prepared.

The scope of BWTP Flows and Loading Alternative 2A is to provide upgrades to the mainstream and sidestream anammox process, with the year-round nitrogen removal to 8-mg/L total inorganic nitrogen (TIN) equivalent (SND/MBR and sidestream anammox). The scope was developed to a Conceptual Design level adequate to assess operations and maintenance issues, energy impacts, permitting and code compliance issues, constructability, estimated costs, and implementation schedule.

The Project Estimate was prepared utilizing the following Work Breakdown Structure (WBS) in order to provide clarity and transparency to the estimated costs. The scope as identified for the alternative is described below in accordance with the WBS. Details are based on the known and defined scope in the design documents provided. See section 3.0 for a detailed list of Design Documents.

- A. Primary Effluent (PE)
  - PE Screen – purchase and install
  - New PE Fine Screening Facility – purchase and install
- B. Aeration Basins
  - General
    - Aeration Basin – purchase and install

## BASIS OF ESTIMATE

Project Name	<b>Brightwater Treatment Plant Nitrogen Removal - Alternative 2A</b>		
Project Number:		Date:	April 28, 2020

- Baffle Wall in New Aeration Basin
- Interior Basin Piping
- C. Membrane Basins
  - Membrane System (new cells) – purchase and install
  - Membrane System (retrofit cells) – purchase and install
  - MBR Bridge Crane Rails and Steel
  - Concrete Membrane Vault Basins – purchase and install
  - Gallery
- D. Internal Mixed Liquor Return (IMLR) Pumping
  - IMLR Pump Equipment – purchase and install
  - 36-inch CS Pipe
  - Demolish Existing Pumps
  - Replace Existing Basin Piping
- E. Return Activated Sludge (RAS) Pump
  - *Not included in the scope for this alternative*
- F. Sidestream Anammox
  - Sidestream Anammox – purchase and install
  - Pumps / Skimmer / Chains / Flight for Sedimentation Tank / Mixers – purchase and install
  - Centrate EQ Tank (60K gal) – purchase and install
  - Centrate Sedimentation Tank (60K gal) – purchase and install
  - Anammox Reactor Tanks (118.5K gal) – purchase and install
- G. Supplemental Methanol System
  - Supplemental Methanol System (30K gal) – purchase and install
- H. Supplemental Alkalinity System
  - *Not included in the scope for this alternative*
- I. Aeration Blowers
  - Aeration Blowers – purchase and install
  - Aeration Blower Diffusers
- J. Aeration Basin Mixers for Anoxic Zones
  - Aeration Basin Mixers – purchase and install
- K. Sidestream Bioaugmentation
  - *Not included in the scope for this alternative*
- L. Tertiary Pumps
  - *Not included in the scope for this alternative*
- M. Tertiary Fixed Film System
  - *Not included in the scope for this alternative*
- N. Aeration / MBR Odor Control
  - New Odor Control Facility – purchase and install
  - Extend and Connect Foul Air Ductwork to Aeration Basins, Side-Stream and Membrane Basins
  - HDPE Buried Foul Air Ductwork
- O. Primary Clarifier / Aerated Grit Tank

## BASIS OF ESTIMATE

Project Name	<b>Brightwater Treatment Plant Nitrogen Removal - Alternative 2A</b>		
Project Number:		Date:	April 28, 2020

- Grit Tank – purchase and install
- P. Miscellaneous Scope
  - Centrate to Sidestream Anammox – purchase and install
  - Anammox Effluent to Grit Tank
  - 36” and 72” CS ML Pipe from Aeration Basin to Membrane Basin
  - ME to Aeration Basin

### 3.0 Design Basis

---

This is an AACE International Class 5 estimate with all required documentation. The estimate is based on engineering deliverables, scoping documentation, discussions with the project team, and all supporting information and documentation provided in December 2019 thru April 2020.

Engineering conceptual scope was provided in the following estimating deliverables. These are the most complete scoping documents that were available to the estimating provider.

Engineering and Estimating Deliverables provided include:

- Brown and Caldwell Layout, Brightwater Nitrogen Removal Study, 7ea. Alternative Marked Up Sketches, (Alt.1/2A/2B/2C/3A/3B/3C), undated
- Brown and Caldwell, Tertiary Feed Pump Station Wetwell layout, Alt. 2C/3C, undated.
- Brown and Caldwell, BW Nitrogen Removal Alt. Cost Estimating Alt1/2A/2B/2C/3A/3B/3C, v0, undated
- KC, WPTP, Aeration Basin Plan View, dated: 01.18.2010
- KC, WPTP, Aeration Basin 2ea Sketch SND Alt.1, dated: 09.05.2013
- KC, WPTP, Aeration Basin 2ea Sketch SND Alt. 2A/3A, dated: 09.05.2013
- KC, WPTP, Aeration Basin 2ea Sketch MLE Alt. 2B/2C/3C, dated: 09.05.2013
- KC, WPTP, Aeration Basin 2ea Sketch 4SMB Alt. 3B, dated: 09.05.2013
- Estimation of MBR as final construction cost of Brightwater, dated: 12.11.2019
- Membrane Tanks 9 and 10 Estimate, Eric Benton, dated: 01.05.2018
- New Aeration Basin, East blower Room and Anoxic Basin Estimate, Eric Benton, dated: 02.06.2018
- Veolia, Biostyr Example Drawings 5ea, dated: 02.27.2019
- BW – YP – SD Model All Yard Piping, undated PDF
- KC WTD, BWTP Vol. 11, General Sheets and Legends, Record Drawings, dated: Nov. 2012
- KC WTD, BWTP Vol. 12, Process and Instrumentation Diagrams, dated: 2013
- KC WTD, BWTP Vol. 22, Mechanical Area 510 Aeration Basins, dated: 2013
- KC WTD, BWTP Vol. 22, Structural Area 510 Aeration Basins, dated: 2013
- KC WTD, BWTP Vol. 23, Mechanical Area 520 Membrane Basins, dated: 2013
- KC WTD, BWTP Vol. 23, Structural Area 520 Membrane Basins, dated: 2013
- KC WTD. BWTP Vol. 16 Headworks Package
- KC WTD. BWTP Vol. 17 Grit Package
- KC WTD. BWTP Vol. 18 Headworks Truck Loadout Package
- KC WTD. BWTP Vol. 19 Primaries Package
- KC WTD. BWTP Vol. 20 PE Screens Package
- KC WTD. BWTP Vol. 21 HW Prim Odor Control Package
- KC WTD. BWTP Vol. 24 Aer MBR Odor Control Package
- KC WTD. BWTP Vol. 25 Disinfection Package

## BASIS OF ESTIMATE

Project Name	<b>Brightwater Treatment Plant Nitrogen Removal - Alternative 2A</b>		
Project Number:		Date:	April 28, 2020

- KC WTD. BWTP Vol. 26 Chem Storage Package
- KC WTD. BWTP Vol. 27 Solids Bldg. Package
- Brightwater Anammox Cap Cost Assumptions
- KC WTD, Aeration Basin #4 RAS Anoxic Basin and Side Stream BOE, dated: 02.18.2018
- KC WTD, BW Membrane Cassettes 9 and 10 BOE, dated: 02.09.2018
- Brightwater Nitrogen Removal Alternatives – Cost Estimating Assumptions V2, undated.

### Equipment Quotes:

- Next Turbo Budget Quote, Aeration Blowers, dated: 10.25.2019
- Suez Budget Quote, MBR, dated: 10.21.2019
- Ovivo Budget Quote, Sidestream Anammox, dated: 12.18.2019
- Biostyr Budget Quote, Tertiary, dated: 12.19.2019
- Fairbanks Quotation Curve, IMLR Pumps, undated.
- Fairbanks Quotation Curve, Tertiary Feed Pumps, undated.

## 4.0 Planning Basis

---

The following planning basis assumptions were made for the project estimate:

- No project construction plan is in place at this time.
- The assumed execution strategy is a standard workweek with limited overtime.
- No unusual site conditions have been considered as part of this estimate.
- Adequate available power exists at the site.

## 5.0 Cost Basis

---

- All allied and indirect project costs (allowances for indeterminates, change order allowance, engineering, permitting, WTD staffing, etc.) have been estimated using WTD's PRISM cost model which is baselined to historical project costs.
- The estimate was performed based on drawings, sketches, and project information provided by King County and Brown and Caldwell Engineers.
- WTD is using a PRISM cost model dated January 26, 2017. All Allied and indirect project costs have been estimated using the new WTD PRISM cost model baselined to historical project costs.
- Additional technical project complexity factors for WTD indirect project costs have been introduced and incorporated into project allied costs to allow for development of an additional WTD indirect cost allowance, based upon the unique characteristics of the project.
- Equipment factors were developed utilizing historical data which accounts for specific install of the identified equipment within a normal battery limit. Specific scope relative to this project was used in the equipment factor determination. Factors for each specific type of equipment reflect the different complexity of the installation. Engineering supplied equipment costs were multiplied by the factors in order to estimate direct construction cost for the purchase and install of the equipment.
- Estimated costs incorporate prevailing King County wage rates.

## BASIS OF ESTIMATE

Project Name	<b>Brightwater Treatment Plant Nitrogen Removal - Alternative 2A</b>		
Project Number:		Date:	April 28, 2020

- All costs were estimated in 1<sup>st</sup> Quarter 2020 dollars.

### 6.0 Allowances

---

The level and types of allowances used in the estimate is as follows (common percentages for each alternative are shown and any estimate-specific differences are indicated):

- Sales Tax was included as 10.1% applied to the base construction cost, including the design and change order contingencies.
- A 25% Allowance for Indeterminates (AFI) is applied to the base construction cost. The AFI is an allowance that accounts for the cost of known but undefined requirements necessary for a complete and workable project. The AFI accounts for elements that are not explicitly shown in the project documents to be further defined as part of the design development and project delivery process. The AFI is carried at 25% at conceptual design, based on the WTD project delivery process.
- Allowance of 10% for potential construction change orders.
- Allowance of 0.2% of the primary construction amount for miscellaneous direct capital costs.
- Allowance of 0.88% of the primary construction amount for permitting and other agency support.
- Allowance of 1.8% of the primary construction amount for miscellaneous services and material.
- Allowance of 0.65% of the primary construction amount for Non-WTD Support.
- Allowance of 1.0% of the primary construction amount for art initiatives.
- Allowance of 0.5% of the total project cost for sustainability.
- Allowance for application of total project contingency (see *Contingency* section below).
- Allowance of 0% was included for Escalation as the estimate is produced in current year (2020) dollars.
- Allowance of 19.36% of the primary construction amount for Engineering Services.
- Allowance of 8.48% of the primary construction amount for Construction Management Support
- Allowance of 12.8% of the primary construction amount for WTD staff labor and burden.
- No Escalation has been included.
- Additional estimating allowances for WTD indirect costs of approximately \$16.53 million have been included in the Total Project Cost estimate by using a moderate degree of complexity rating for Design Engineering, Construction Management, Operations Support, and Project Management. Complexity factors were calibrated based on comments received from King County on March 04, 2020.
  - An allowance of \$13.17 million for Design and Construction Consulting
  - An allowance of \$0 million for Permitting & Other Agency Support
  - An allowance of \$3.35 million for WTD Staff Labor

## **BASIS OF ESTIMATE**

Project Name	<b>Brightwater Treatment Plant Nitrogen Removal - Alternative 2A</b>		
Project Number:		Date:	April 28, 2020

### **7.0 Assumptions**

---

Any other assumptions made by the estimator but not documented elsewhere in the estimate basis are included in this section.

- All costs included in the estimate reflect the best understanding of requirements as they existed at the time the estimates were prepared. Any modifications to the present scope and/or location of the project site may have substantial cost and schedule impacts.
- The engineering design will be performed by an external consultant engineer.
- Construction management will not be performed ‘in-house’ by WTD. It will be performed by an external consultant construction manager.
- The project will generally align with the WTD PRISM cost model for Treatment projects.
- All work will always be performed utilizing safe work methods.
- Work will be sequenced to minimize standard process, service, and community interruptions. However, no costs are included to address sequencing necessary to keep the plant operational during construction.
- No costs are included for any new facilities that would be required, beyond the scope of this project to replace any lost capacity to the Brightwater Treatment Plant.
- It is assumed that the best improvement solution is included in the project scope(s).
- There will be some degree of productivity loss due to the site location. Some degree of productivity loss is included in the estimated costs. Any unusual site conditions are not accounted for in this estimate.
- Any additional work discovered during project implementation would need to be either a supplemental approval of added scope or be approved as an additional project.
- This project will be engineered to meet Washington State area seismic requirements.
- A degree of minimal cost rounding will occur during the normal estimating process.
- No allowance is included for Material Pricing Uncertainty.
- Power is readily available in the general area of this project. No new power sources are included in the scope of this project.
- It is assumed that some general material contamination is present. The estimate covers minimal cost of removal wherever the contamination is disturbed during construction. This cost is covered in productivity rates utilized in the estimate.

### **8.0 Exclusions**

---

All potential items of cost which might be associated with the project but for which no costs have been included are listed below:

- No asbestos removal costs are included.
- No estimated costs are included for any potential delays due to interferences.



## BASIS OF ESTIMATE

Project Name	<b>Brightwater Treatment Plant Nitrogen Removal - Alternative 2A</b>		
Project Number:		Date:	April 28, 2020

- No costs are included for utility relocations.
- No costs are included for temporary construction easements.
- No costs are included for street use or street improvement permits.
- No costs are included for additional scope beyond that as detailed in the current scope of work.

### 9.0 Exceptions

---

This estimate is classified as a King County Wastewater Treatment Division Class 5 estimate based on an AACE International Class 5 estimate, with no exceptions per the King County WTD project process, for the scope as known at the time of the estimate preparation.

### 10.0 Risks (Threats and Opportunities)

---

At the time of estimate preparation, a formal risk analysis session had not been conducted. General potential risks are listed below.

- There is a risk that additional scope, technology advances or major deviation from the suggested project scope will adversely impact cost and schedule.
- Future unknown or changing site conditions present a risk around productivities, schedule, and costs.
- More stringent or completely new regulations, usage fees, permitting, or environmental impacts may result in risks that could adversely impact cost and schedule.
- Potential complex construction and constructability issues could arise during construction, resulting in major design/construction changes.
- The space constraints could significantly impact assumed productivities and crew sizes identified for the estimated concept, resulting in increased costs due to loss of production.
- The scheduled timing of project execution will greatly impact the bottom-line costs. There is risk related to labor availability and fluctuating commodity and equipment pricing in the timeframe between this early conceptual estimate and the actual execution of the project. Rising costs due to inflation, escalation and competing major worldwide projects pose the possibility of noticeable project cost and schedule increases.
- Weather conditions and emergency service interruptions present the possibility of negative schedule and cost impacts.
- Any possible coordination with other agencies could result in potential impacts on costs, schedule and Project Definition process.
- There is a risk that stakeholders could oppose the proposed design or prefer a different approach or site to be selected, resulting in schedule delays and a higher cost alternative.

## **BASIS OF ESTIMATE**

Project Name	<b>Brightwater Treatment Plant Nitrogen Removal - Alternative 2A</b>		
Project Number:		Date:	April 28, 2020

---

### **11.0 Contingency**

Contingency is a cost element of the estimate used to cover uncertainties and unforeseeable elements of cost within the defined project scope. Contingency covers inadequacies in project scope definition, estimating methods, and estimating data. Contingency specifically excludes changes in project scope, and unforeseen major events such as earthquakes, prolonged labor strikes, etc.

A 30% Project Contingency was added to the base estimate of Total Project Costs (direct and indirect) as a result of the project estimating process and in accordance with the King County WTD project delivery process.

The estimating analysis resulted in a project contingency of approximately \$74.1 million (US\$).

The total project cost at a 50% confidence level (P50) is typically used for funding and baselining of a project at this stage and level of engineering and project development. The P50 confidence level suggests that there is a 50% cumulative probability of project cost under-run (or 50% probability of exceedance) at this dollar amount for the presently defined and known project scope.

---

### **12.0 Management Reserve**

No allocation of costs was included in this estimate for Management Reserves.

Contingency is not intended to cover the costs for changes in project scope. If the project needs to provide an allowance for anticipated changes in scope or to cover the costs for items that may be required but have not yet been specifically identified as being included in the current project scope, then that amount of cost should be identified here.

---

### **13.0 Reconciliation**

Reconciliation was not conducted at this time.

---

### **14.0 Benchmarking**

All included Allied Costs as supplied by the PRISM historical database have been benchmarked against a similar portfolio of recently completed projects.

---

### **15.0 Estimate Quality Assurance Plan**

No reviews of total project costs have been conducted outside the reviews conducted within Brown and Caldwell and VMS estimating team. It is anticipated that upon completion of this estimate, reviews will happen between the estimate provider and WTD.

---

### **16.0 Attachments**

#### **Attachment: Estimate Deliverables**

Engineering and Estimating Deliverables provided include:

- Brown and Caldwell Layout, Brightwater Nitrogen Removal Study, 7ea. Alternative Marked Up Sketches, (Alt. 1/2A/2B/2C/3A/3B/3C), undated
- Brown and Caldwell, Tertiary Feed Pump Station Wetwell layout, Alt. 2C/3C, undated.

## BASIS OF ESTIMATE

Project Name	<b>Brightwater Treatment Plant Nitrogen Removal - Alternative 2A</b>		
Project Number:		Date:	April 28, 2020

- Brown and Caldwell, BW Nitrogen Removal Alt. Cost Estimating Alt1/2A/2B/2C/3A/3B/3C, v0, undated
- KC, WPTP, Aeration Basin Plan View, dated: 01.18.2010
- KC, WPTP, Aeration Basin 2ea Sketch SND Alt.1, dated: 09.05.2013
- KC, WPTP, Aeration Basin 2ea Sketch SND Alt. 2A/3A, dated: 09.05.2013
- KC, WPTP, Aeration Basin 2ea Sketch MLE Alt. 2B/2C/3C, dated: 09.05.2013
- KC, WPTP, Aeration Basin 2ea Sketch 4SMB Alt. 3B, dated: 09.05.2013
- Estimation of MBR as final construction cost of Brightwater, dated: 12.11.2019
- Membrane Tanks 9 and 10 Estimate, Eric Benton, dated: 01.05.2018
- New Aeration Basin, East blower Room and Anoxic Basin Estimate, Eric Benton, dated: 02.06.2018
- Veolia, Biostyr Example Drawings 5ea, dated: 02.27.2019
- BW – YP – SD Model All Yard Piping, undated PDF
- KC WTD, BWTP Vol.11, General Sheets and Legends, Record Drawings, dated: Nov. 2012
- KC WTD, BWTP Vol. 12, Process and Instrumentation Diagrams, dated: 2013
- KC WTD, BWTP Vol. 22, Mechanical Area 510 Aeration Basins, dated: 2013
- KC WTD, BWTP Vol. 22, Structural Area 510 Aeration Basins, dated: 2013
- KC WTD, BWTP Vol. 23, Mechanical Area 520 Membrane Basins, dated: 2013
- KC WTD, BWTP Vol. 23, Structural Area 520 Membrane Basins, dated: 2013
- KC WTD. BWTP Vol. 16 Headworks Package
- KC WTD. BWTP Vol. 17 Grit Package
- KC WTD. BWTP Vol. 18 Headworks Truck Loadout Package
- KC WTD. BWTP Vol. 19 Primaries Package
- KC WTD. BWTP Vol. 20 PE Screens Package
- KC WTD. BWTP Vol. 21 HW Prim Odor Control Package
- KC WTD. BWTP Vol. 24 Aer MBR Odor Control Package
- KC WTD. BWTP Vol. 25 Disinfection Package
- KC WTD. BWTP Vol. 26 Chem Storage Package
- KC WTD. BWTP Vol. 27 Solids Bldg. Package
- Brightwater Anammox Cap Cost Assumptions
- KC WTD, Aeration Basin #4 RAS Anoxic Basin and Side Stream BOE, dated: 02.18.2018
- KC WTD, BW Membrane Cassettes 9 and 10 BOE, dated: 02.09.2018
- Brightwater Nitrogen Removal Alternatives – Cost Estimating Assumptions V2, undated.

### Equipment Quotes:

- Next Turbo Budget Quote, Aeration Blowers, dated: 10.25.2019
- Suez Budget Quote, MBR, dated: 10.21.2019
- Ovivo Budget Quote, Sidestream Anammox, dated: 12.18.2019
- Biostyr Budget Quote, Tertiary, dated: 12.19.2019
- Fairbanks Quotation Curve, IMLR Pumps, undated.
- Fairbanks Quotation Curve, Tertiary Feed Pumps, undated.



# King County

Department of Natural Resources and Parks  
Wastewater Treatment Division

## Project Planning and Delivery Section

### BASIS OF ESTIMATE

---

Project Name	<b>Brightwater Treatment Plant Nitrogen Removal - Alternative 2B</b>
Project Number	
Date Prepared	April 28, 2020
Requested by	Tiffany Knapp, King County WTD
Prepared by	Douglas W. Leo, CCP, CEP, FRICS, FAACE Hon. Life, (VMS, Inc.)
Estimate Classification	WTD Class 5
Estimate Purpose	King County Class 5 Concept Screening
Estimate ID (Version)	5
Project Manager	Eron Jacobson, King County WTD
Project Control Engineer	
Cc or Distribution List	

*Note that the accuracy of the associated cost estimate is dependent upon the various underlying assumptions, inclusions, and exclusions described herein. Actual project costs may differ and can be significantly affected by factors such as changes in the external environment, the manner in which the project is executed and controlled, and other factors that may impact the estimate basis or otherwise affect the project. Estimate accuracy ranges are only assessments based upon the cost estimating methods and data employed in preparing the estimate and are not a guarantee of actual project costs.*

## BASIS OF ESTIMATE

Project Name	<b>Brightwater Treatment Plant Nitrogen Removal - Alternative 2B</b>		
Project Number:		Date:	April 28, 2020

### 1.0 Purpose

---

The purpose of this estimate is to provide cost information to support King County's Brightwater Treatment Plant (BWTP) Flows and Loading Alternative Evaluation for the Nitrogen Removal Project. A series of alternatives have been developed for project evaluation to determine the best engineering and project cost solution.

This estimate was prepared to establish a King County Wastewater Treatment Division (WTD) pre-Class 5 conceptual cost estimate to provide order of magnitude cost to support WTD's capital project identification and budgeting process for Total Project Costs. The WTD pre-Class 5 estimate provides similar documentation to that of an AACE International Class 5 estimate. The range of anticipated project costs, per WTD estimating guidance, is -50% / +300%. The range of uncertainty is beyond that for a typical Class 5 estimate due to the scope being proximally defined with today's relative solutions and technologies to resolving the identified needs; when the projects move forward into capital delivery over the longer term, it is anticipated that many differences and changes may arise as the known and defined engineering solutions are developed.

Douglas Leo of Value Management Strategies, Inc. (VMS) prepared this Basis of Estimate in coordination with King County WTD, the Brown and Caldwell Engineers team, and the VMS estimating team after receiving scope information from WTD in December 2019 thru April 2020. This Basis of Estimate reflects VMS's best understanding of the estimating process for this project, as explained by King County WTD and Brown and Caldwell.

### 2.0 Project Scope Definition

---

This estimate includes all investigation, administration/owners' costs, engineering and design, purchases, fabrications, installations, process certifications, permitting, community impacts, and miscellaneous costs not specifically excluded elsewhere in this document.

Comprehensive Total Field Costs are generated from historical allowances, sources such as WTD estimating tools, historical costs, and RS Means/VMS estimating databases. All supporting indirect costs were generated from the WTD PRISM historical database. All costs included in the estimate reflect the best understanding of requirements as they existed at the time this estimate was prepared.

The scope of BWTP Flows and Loading Alternative 2B is to provide MLE/MBR and sidestream Anammox process, with the year-round nitrogen removal to 8-mg/L total inorganic nitrogen (TIN) equivalent. The scope was developed to a Conceptual Design level adequate to assess operations and maintenance issues, energy impacts, permitting and code compliance issues, constructability, estimated costs, and implementation schedule.

The Project Estimate was prepared utilizing the following Work Breakdown Structure (WBS) in order to provide clarity and transparency to the estimated costs. The scope as identified for the alternative is described below in accordance with the WBS. Details are based on the known and defined scope in the design documents provided. See section 3.0 for a detailed list of Design Documents.

- A. Primary Effluent (PE)
  - PE Screen – purchase and install
  - New PE Fine Screening Facility – purchase and install
- B. Aeration Basins
  - General
    - New Aeration Basin Trains – purchase and install

## BASIS OF ESTIMATE

Project Name	<b>Brightwater Treatment Plant Nitrogen Removal - Alternative 2B</b>		
Project Number:		Date:	April 28, 2020

- Baffle Wall in New Aeration Basins
  - Baffle Walls in Existing Aeration Basins
  - Interior Basin Piping
- C. Membrane Basins
- Membrane System (new cell) – purchase and install
  - Membrane System (retrofit cell) – purchase and install
  - MBR Bridge Crane Rails and Steel
  - Concrete Membrane Vault Basins – purchase and install
  - Gallery
- D. Internal Mixed Liquor Return (IMLR) Pumping
- IMLR Pump Equipment – purchase and install
  - 36" CS Pipe (8ea pumps, 2/cells, 200LF/EA)
  - Demo Existing Pumps
  - Replace existing basin piping
- E. Return Activated Sludge (RAS) Pump
- *Not included in the scope for this alternative*
- F. Sidestream Anammox
- Sidestream Anammox – purchase and install
  - Pumps / Skimmer / Chains / Flight for Sedimentation Tank / Mixers – purchase and install
  - Centrate EQ Tank (60K gal) -purchase and install
  - Centrate Sedimentation Tank (60K gal) – purchase and install
  - Anammox Reactor Tanks (118.5K gal) – purchase and install
- G. Supplemental Methanol System
- Supplemental Methanol System (30K gal) – purchase and install
- H. Supplemental Alkalinity System
- *Not included in the scope for this alternative*
- I. Aeration Blowers
- Aeration Blowers – purchase and install
  - Aeration Blower Diffusers
- J. Aeration Basin Mixers for Anoxic Zones
- Aeration Basin Mixers – purchase and install
- K. Sidestream Bioaugmentation
- *Not included in the scope for this alternative*
- L. Tertiary Pumps
- *Not included in the scope for this alternative*
- M. Tertiary Fixed Film System
- *Not included in the scope for this alternative*
- N. Aeration / MBR Odor Control
- New Odor Control Facility – purchase and install
  - Extend and connect Foul Air Ductwork to Aeration Basins, Side-Stream and Membrane Basins
  - HDPE buried foul air ductwork

## BASIS OF ESTIMATE

Project Name	<b>Brightwater Treatment Plant Nitrogen Removal - Alternative 2B</b>		
Project Number:		Date:	April 28, 2020

- O. Primary Clarifier / Aerated Grit Tank
  - Grit Tank – purchase and install
- P. Miscellaneous Scope
  - Centrate to Sidestream Anammox – purchase and install
  - Anammox Effluent to Grit Tank
  - 36” and 72” CS ML Piping from Aeration Basin to Membrane Basin
  - ME to Aeration Basin

### 3.0 Design Basis

---

This is an AACE International Class 5 estimate with all required documentation. The estimate is based on engineering deliverables, scoping documentation, discussions with the project team, and all supporting information and documentation provided in December 2019 thru April 2020.

Engineering conceptual scope was provided in the following estimating deliverables. These are the most complete scoping documents that were available to the estimating provider.

Engineering and Estimating Deliverables provided include:

- Brown and Caldwell Layout, Brightwater Nitrogen Removal Study, 7ea. Alternative Marked Up Sketches, (Alt.1/2A/2B/2C/3A/3B/3C), undated
- Brown and Caldwell, Tertiary Feed Pump Station Wetwell layout, Alt. 2C/3C, undated.
- Brown and Caldwell, BW Nitrogen Removal Alt. Cost Estimating Alt1/2A/2B/2C/3A/3B/3C, v0, undated
- KC, WPTP, Aeration Basin Plan View, dated: 01.18.2010
- KC, WPTP, Aeration Basin 2ea Sketch SND Alt.1, dated: 09.05.2013
- KC, WPTP, Aeration Basin 2ea Sketch SND Alt. 2A/3A, dated: 09.05.2013
- KC, WPTP, Aeration Basin 2ea Sketch MLE Alt. 2B/2C/3C, dated: 09.05.2013
- KC, WPTP, Aeration Basin 2ea Sketch 4SMB Alt. 3B, dated: 09.05.2013
- Estimation of MBR as final construction cost of Brightwater, dated: 12.11.2019
- Membrane Tanks 9 and 10 Estimate, Eric Benton, dated: 01.05.2018
- New Aeration Basin, East blower Room and Anoxic Basin Estimate, Eric Benton, dated: 02.06.2018
- Veolia, Biostyr Example Drawings 5ea, dated: 02.27.2019
- BW – YP – SD Model All Yard Piping, undated PDF
- KC WTD, BWTP Vol.11, General Sheets and Legends, Record Drawings, dated: Nov. 2012
- KC WTD, BWTP Vol. 12, Process and Instrumentation Diagrams, dated: 2013
- KC WTD, BWTP Vol. 22, Mechanical Area 510 Aeration Basins, dated: 2013
- KC WTD, BWTP Vol. 22, Structural Area 510 Aeration Basins, dated: 2013
- KC WTD, BWTP Vol. 23, Mechanical Area 520 Membrane Basins, dated: 2013
- KC WTD, BWTP Vol. 23, Structural Area 520 Membrane Basins, dated: 2013
- KC WTD. BWTP Vol. 16 Headworks Package
- KC WTD. BWTP Vol. 17 Grit Package
- KC WTD. BWTP Vol. 18 Headworks Truck Loadout Package
- KC WTD. BWTP Vol. 19 Primaries Package
- KC WTD. BWTP Vol. 20 PE Screens Package
- KC WTD. BWTP Vol. 21 HW Prim Odor Control Package
- KC WTD. BWTP Vol. 24 Aer MBR Odor Control Package



## BASIS OF ESTIMATE

Project Name	<b>Brightwater Treatment Plant Nitrogen Removal - Alternative 2B</b>		
Project Number:		Date:	April 28, 2020

- KC WTD. BWTP Vol. 25 Disinfection Package
- KC WTD. BWTP Vol. 26 Chem Storage Package
- KC WTD. BWTP Vol. 27 Solids Bldg. Package
- Brightwater Anammox Cap Cost Assumptions
- KC WTD, Aeration Basin #4 RAS Anoxic Basin and Side Stream BOE, dated: 02.18.2018
- KC WTD, BW Membrane Cassettes 9 and 10 BOE, dated: 02.09.2018
- Brightwater Nitrogen Removal Alternatives – Cost Estimating Assumptions V2, undated.

### Equipment Quotes:

- Next Turbo Budget Quote, Aeration Blowers, dated: 10.25.2019
- Suez Budget Quote, MBR, dated: 10.21.2019
- Ovivo Budget Quote, Sidestream Anammox, dated: 12.18.2019
- Biostyr Budget Quote, Tertiary, dated: 12.19.2019
- Fairbanks Quotation Curve, IMLR Pumps, undated.
- Fairbanks Quotation Curve, Tertiary Feed Pumps, undated.

## 4.0 Planning Basis

---

The following planning basis assumptions were made for the project estimate:

- No project construction plan is in place at this time.
- The assumed execution strategy is a standard workweek with limited overtime.
- No unusual site conditions have been considered as part of this estimate.
- Adequate available power exists at the site.

## 5.0 Cost Basis

---

- All allied and indirect project costs (allowances for indeterminates, change order allowance, engineering, permitting, WTD staffing, etc.) have been estimated using WTD's PRISM cost model which is baselined to historical project costs.
- The estimate was performed based on drawings, sketches, and project information provided by King County and Brown and Caldwell Engineers.
- WTD is using a PRISM cost model dated January 26, 2017. All Allied and indirect project costs have been estimated using the new WTD PRISM cost model baselined to historical project costs.
- Additional technical project complexity factors for WTD indirect project costs have been introduced and incorporated into project allied costs to allow for development of an additional WTD indirect cost allowance, based upon the unique characteristics of the project.
- Equipment factors were developed utilizing historical data which accounts for specific install of the identified equipment within a normal battery limit. Specific scope relative to this project was used in the equipment factor determination. Factors for each specific type of equipment reflect the different complexity of the installation. Engineering supplied equipment costs were multiplied by the factors in order to estimate direct construction cost for the purchase and install of the equipment.

## BASIS OF ESTIMATE

Project Name	<b>Brightwater Treatment Plant Nitrogen Removal - Alternative 2B</b>		
Project Number:		Date:	April 28, 2020

- Estimated costs incorporate prevailing King County wage rates.
- All costs were estimated in 1<sup>st</sup> Quarter 2020 dollars.

### 6.0 Allowances

---

The level and types of allowances used in the estimate is as follows (common percentages for each alternative are shown and any estimate-specific differences are indicated):

- Sales Tax was included as 10.1% applied to the base construction cost, including the design and change order contingencies.
- A 25% Allowance for Indeterminates (AFI) is applied to the base construction cost. The AFI is an allowance that accounts for the cost of known but undefined requirements necessary for a complete and workable project. The AFI accounts for elements that are not explicitly shown in the project documents to be further defined as part of the design development and project delivery process. The AFI is carried at 25% at conceptual design, based on the WTD project delivery process.
- Allowance of 10% for potential construction change orders.
- Allowance of 0.2% of the primary construction amount for miscellaneous direct capital costs.
- Allowance of 0.88% of the primary construction amount for permitting and other agency support.
- Allowance of 1.8% of the primary construction amount for miscellaneous services and material.
- Allowance of 0.65% of the primary construction amount for Non-WTD Support.
- Allowance of 1.0% of the primary construction amount for art initiatives.
- Allowance of 0.5% of the total project cost for sustainability.
- Allowance for application of total project contingency (see *Contingency* section below).
- Allowance of 0% was included for Escalation as the estimate is produced in current year (2020) dollars.
- Allowance of 19.32% of the primary construction amount for Engineering Services.
- Allowance of 8.46% of the primary construction amount for Construction Management Support
- Allowance of 12.78% of the primary construction amount for WTD staff labor and burden.
- No Escalation has been included.
- Additional estimating allowances for WTD indirect costs of approximately \$16.72 million have been included in the Total Project Cost estimate by using a moderate degree of complexity rating for Design Engineering, Construction Management, Operations Support, and Project Management. Complexity factors were calibrated based on comments received from King County on March 04, 2020.
  - An allowance of \$13.32 million for Design and Construction Consulting
  - An allowance of \$0 million for Permitting & Other Agency Support
  - An allowance of \$3.39 million for WTD Staff Labor

## **BASIS OF ESTIMATE**

Project Name	<b>Brightwater Treatment Plant Nitrogen Removal - Alternative 2B</b>		
Project Number:		Date:	April 28, 2020

### **7.0 Assumptions**

---

Any other assumptions made by the estimator but not documented elsewhere in the estimate basis are included in this section.

- All costs included in the estimate reflect the best understanding of requirements as they existed at the time the estimates were prepared. Any modifications to the present scope and/or location of the project site may have substantial cost and schedule impacts.
- The engineering design will be performed by an external consultant engineer.
- Construction management will not be performed “in-house” by WTD. It will be performed by an external consultant construction manager.
- The project will generally align with the WTD PRISM cost model for Treatment projects.
- All work will always be performed utilizing safe work methods.
- Work will be sequenced to minimize standard process, service, and community interruptions. However, no costs are included to address sequencing necessary to keep the plant operational during construction.
- No costs are included for any new facilities that would be required, beyond the scope of this project to replace any lost capacity to the Brightwater Treatment Plant.
- It is assumed that the best improvement solution is included in the project scope(s).
- There will be some degree of productivity loss due to the site location. Some degree of productivity loss is included in the estimated costs. Any unusual site conditions are not accounted for in this estimate.
- Any additional work discovered during project implementation would need to be either a supplemental approval of added scope or be approved as an additional project.
- This project will be engineered to meet Washington State area seismic requirements.
- A degree of minimal cost rounding will occur during the normal estimating process.
- No allowance is included for Material Pricing Uncertainty.
- Power is readily available in the general area of this project. No new power sources are included in the scope of this project.
- It is assumed that some general material contamination is present. The estimate covers minimal cost of removal wherever the contamination is disturbed during construction. This cost is covered in productivity rates utilized in the estimate.

### **8.0 Exclusions**

---

All potential items of cost which might be associated with the project but for which no costs have been included are listed below:

- No asbestos removal costs are included.
- No estimated costs are included for any potential delays due to interferences.
- No costs are included for utility relocations.

## **BASIS OF ESTIMATE**

Project Name	<b>Brightwater Treatment Plant Nitrogen Removal - Alternative 2B</b>		
Project Number:		Date:	April 28, 2020

- No costs are included for temporary construction easements.
- No costs are included for street use or street improvement permits.
- No costs are included for additional scope beyond that as detailed in the current scope of work.

### **9.0 Exceptions**

---

This estimate is classified as a King County Wastewater Treatment Division Class 5 estimate based on an AACE International Class 5 estimate, with no exceptions per the King County WTD project process, for the scope as known at the time of the estimate preparation.

### **10.0 Risks (Threats and Opportunities)**

---

At the time of estimate preparation, a formal risk analysis session had not been conducted. General potential risks are listed below.

- There is a risk that additional scope, technology advances or major deviation from the suggested project scope will adversely impact cost and schedule.
- Future unknown or changing site conditions present a risk around productivities, schedule, and costs.
- More stringent or completely new regulations, usage fees, permitting, or environmental impacts may result in risks that could adversely impact cost and schedule.
- Potential complex construction and constructability issues could arise during construction, resulting in major design/construction changes.
- The space constraints could significantly impact assumed productivities and crew sizes identified for the estimated concept, resulting in increased costs due to loss of production.
- The scheduled timing of project execution will greatly impact the bottom-line costs. There is risk related to labor availability and fluctuating commodity and equipment pricing in the timeframe between this early conceptual estimate and the actual execution of the project. Rising costs due to inflation, escalation and competing major worldwide projects pose the possibility of noticeable project cost and schedule increases.
- Weather conditions and emergency service interruptions present the possibility of negative schedule and cost impacts.
- Any possible coordination with other agencies could result in potential impacts on costs, schedule and Project Definition process.
- There is a risk that stakeholders could oppose the proposed design or prefer a different approach or site to be selected, resulting in schedule delays and a higher cost alternative.

## **BASIS OF ESTIMATE**

Project Name	<b>Brightwater Treatment Plant Nitrogen Removal - Alternative 2B</b>		
Project Number:		Date:	April 28, 2020

### **11.0 Contingency**

---

Contingency is a cost element of the estimate used to cover uncertainties and unforeseeable elements of cost within the defined project scope. Contingency covers inadequacies in project scope definition, estimating methods, and estimating data. Contingency specifically excludes changes in project scope, and unforeseen major events such as earthquakes, prolonged labor strikes, etc.

A 30% Project Contingency was added to the base estimate of Total Project Costs (direct and indirect) as a result of the project estimating process and in accordance with the King County WTD project delivery process.

The estimating analysis resulted in a project contingency of approximately \$75.1 million (US\$).

The total project cost at a 50% confidence level (P50) is typically used for funding and baselining of a project at this stage and level of engineering and project development. The P50 confidence level suggests that there is a 50% cumulative probability of project cost under-run (or 50% probability of exceedance) at this dollar amount for the presently defined and known project scope.

### **12.0 Management Reserve**

---

No allocation of costs was included in this estimate for Management Reserves.

Contingency is not intended to cover the costs for changes in project scope. If the project needs to provide an allowance for anticipated changes in scope or to cover the costs for items that may be required but have not yet been specifically identified as being included in the current project scope, then that amount of cost should be identified here.

### **13.0 Reconciliation**

---

Reconciliation was not conducted at this time.

### **14.0 Benchmarking**

---

All included Allied Costs as supplied by the PRISM historical database have been benchmarked against a similar portfolio of recently completed projects.

### **15.0 Estimate Quality Assurance Plan**

---

No reviews of total project costs have been conducted outside the reviews conducted within Brown and Caldwell and VMS estimating team. It is anticipated that upon completion of this estimate, reviews will happen between the estimate provider and WTD.

### **16.0 Attachments**

---

#### **Attachment: Estimate Deliverables**

Engineering and Estimating Deliverables provided include:

- Brown and Caldwell Layout, Brightwater Nitrogen Removal Study, 7ea. Alternative Marked Up Sketches, (Alt. 1/2A/2B/2C/3A/3B/3C), undated
- Brown and Caldwell, Tertiary Feed Pump Station Wetwell layout, Alt. 2C/3C, undated.

## BASIS OF ESTIMATE

Project Name	<b>Brightwater Treatment Plant Nitrogen Removal - Alternative 2B</b>		
Project Number:		Date:	April 28, 2020

- Brown and Caldwell, BW Nitrogen Removal Alt. Cost Estimating Alt1/2A/2B/2C/3A/3B/3C, v0, undated
- KC, WPTP, Aeration Basin Plan View, dated: 01.18.2010
- KC, WPTP, Aeration Basin 2ea Sketch SND Alt.1, dated: 09.05.2013
- KC, WPTP, Aeration Basin 2ea Sketch SND Alt. 2A/3A, dated: 09.05.2013
- KC, WPTP, Aeration Basin 2ea Sketch MLE Alt. 2B/2C/3C, dated: 09.05.2013
- KC, WPTP, Aeration Basin 2ea Sketch 4SMB Alt. 3B, dated: 09.05.2013
- Estimation of MBR as final construction cost of Brightwater, dated: 12.11.2019
- Membrane Tanks 9 and 10 Estimate, Eric Benton, dated: 01.05.2018
- New Aeration Basin, East blower Room and Anoxic Basin Estimate, Eric Benton, dated: 02.06.2018
- Veolia, Biostyr Example Drawings 5ea, dated: 02.27.2019
- BW – YP – SD Model All Yard Piping, undated PDF
- KC WTD, BWTP Vol.11, General Sheets and Legends, Record Drawings, dated: Nov. 2012
- KC WTD, BWTP Vol. 12, Process and Instrumentation Diagrams, dated: 2013
- KC WTD, BWTP Vol. 22, Mechanical Area 510 Aeration Basins, dated: 2013
- KC WTD, BWTP Vol. 22, Structural Area 510 Aeration Basins, dated: 2013
- KC WTD, BWTP Vol. 23, Mechanical Area 520 Membrane Basins, dated: 2013
- KC WTD, BWTP Vol. 23, Structural Area 520 Membrane Basins, dated: 2013
- KC WTD. BWTP Vol. 16 Headworks Package
- KC WTD. BWTP Vol. 17 Grit Package
- KC WTD. BWTP Vol. 18 Headworks Truck Loadout Package
- KC WTD. BWTP Vol. 19 Primaries Package
- KC WTD. BWTP Vol. 20 PE Screens Package
- KC WTD. BWTP Vol. 21 HW Prim Odor Control Package
- KC WTD. BWTP Vol. 24 Aer MBR Odor Control Package
- KC WTD. BWTP Vol. 25 Disinfection Package
- KC WTD. BWTP Vol. 26 Chem Storage Package
- KC WTD. BWTP Vol. 27 Solids Bldg. Package
- Brightwater Anammox Cap Cost Assumptions
- KC WTD, Aeration Basin #4 RAS Anoxic Basin and Side Stream BOE, dated: 02.18.2018
- KC WTD, BW Membrane Cassettes 9 and 10 BOE, dated: 02.09.2018
- Brightwater Nitrogen Removal Alternatives – Cost Estimating Assumptions V2, undated.

### Equipment Quotes:

- Next Turbo Budget Quote, Aeration Blowers, dated: 10.25.2019
- Suez Budget Quote, MBR, dated: 10.21.2019
- Ovivo Budget Quote, Sidestream Anammox, dated: 12.18.2019
- Biostyr Budget Quote, Tertiary, dated: 12.19.2019
- Fairbanks Quotation Curve, IMLR Pumps, undated.
- Fairbanks Quotation Curve, Tertiary Feed Pumps, undated.



# King County

Department of Natural Resources and Parks  
Wastewater Treatment Division

## Project Planning and Delivery Section

### BASIS OF ESTIMATE

---

Project Name	<b>Brightwater Treatment Plant Nitrogen Removal - Alternative 2C</b>
Project Number	
Date Prepared	April 28, 2020
Requested by	Tiffany Knapp, King County WTD
Prepared by	Douglas W. Leo, CCP, CEP, FRICS, FAACE Hon. Life, (VMS, Inc.)
Estimate Classification	WTD Class 5
Estimate Purpose	King County Class 5 Concept Screening
Estimate ID (Version)	5
Project Manager	Eron Jacobson, King County WTD
Project Control Engineer	
Cc or Distribution List	

*Note that the accuracy of the associated cost estimate is dependent upon the various underlying assumptions, inclusions, and exclusions described herein. Actual project costs may differ and can be significantly affected by factors such as changes in the external environment, the manner in which the project is executed and controlled, and other factors that may impact the estimate basis or otherwise affect the project. Estimate accuracy ranges are only assessments based upon the cost estimating methods and data employed in preparing the estimate and are not a guarantee of actual project costs.*



## BASIS OF ESTIMATE

Project Name	<b>Brightwater Treatment Plant Nitrogen Removal - Alternative 2C</b>		
Project Number:		Date:	April 28, 2020

### 1.0 Purpose

---

The purpose of this estimate is to provide cost information to support King County's Brightwater Treatment Plant (BWTP) Flows and Loading Alternative Evaluation for the Nitrogen Removal Project. A series of alternatives have been developed for project evaluation to determine the best engineering and project cost solution.

This estimate was prepared to establish a King County Wastewater Treatment Division (WTD) pre-Class 5 conceptual cost estimate to provide order of magnitude cost to support WTD's capital project identification and budgeting process for Total Project Costs. The WTD pre-Class 5 estimate provides similar documentation to that of an AACE International Class 5 estimate. The range of anticipated project costs, per WTD estimating guidance, is -50% / +300%. The range of uncertainty is beyond that for a typical Class 5 estimate due to the scope being proximally defined with today's relative solutions and technologies to resolving the identified needs; when the projects move forward into capital delivery over the longer term, it is anticipated that many differences and changes may arise as the known and defined engineering solutions are developed.

Douglas Leo of Value Management Strategies, Inc. (VMS) prepared this Basis of Estimate in coordination with King County WTD, the Brown and Caldwell Engineers team, and the VMS estimating team after receiving scope information from WTD in December 2019 thru April 2020. This Basis of Estimate reflects VMS's best understanding of the estimating process for this project, as explained by King County WTD and Brown and Caldwell.

### 2.0 Project Scope Definition

---

This estimate includes all investigation, administration/owners' costs, engineering and design, purchases, fabrications, installations, process certifications, permitting, community impacts, and miscellaneous costs not specifically excluded elsewhere in this document.

Comprehensive Total Field Costs are generated from historical allowances, sources such as WTD estimating tools, historical costs, and RS Means/VMS estimating databases. All supporting indirect costs were generated from the WTD PRISM historical database. All costs included in the estimate reflect the best understanding of requirements as they existed at the time this estimate was prepared.

The scope of BWTP Flows and Loading Alternative 2C is to provide MLE/MBR, Tertiary Denitrifying Fixed-Film and sidestream Anammox process, with the year-round nitrogen removal to 8-mg/L total inorganic nitrogen TIN equivalent (MLE/MBR and tertiary denitrifying fixed-film and sidestream anammox). The scope was developed to a Conceptual Design level adequate to assess operations and maintenance issues, energy impacts, permitting and code compliance issues, constructability, estimated costs, and implementation schedule.

The Project Estimate was prepared utilizing the following Work Breakdown Structure (WBS) in order to provide clarity and transparency to the estimated costs. The scope as identified for the alternative is described below in accordance with the WBS. Details are based on the known and defined scope in the design documents provided. See section 3.0 for a detailed list of Design Documents.

- A. Primary Effluent (PE)
  - PE Screen – purchase and install
  - New PE Fine Screening Facility – purchase and install
- B. Aeration Basins
  - General
    - New Aeration Basin Trains – purchase and install

## BASIS OF ESTIMATE

Project Name	<b>Brightwater Treatment Plant Nitrogen Removal - Alternative 2C</b>		
Project Number:		Date:	April 28, 2020

- Interior Cell Walls in New Aeration Basin
  - Baffle Wall in New Aeration Basins
  - Baffle Walls in Existing Aeration Basins
  - Interior Basin Piping
- C. Membrane Basins
- Membrane System (new cells) – purchase and install
  - Membrane System (retrofit cells)
  - MBR Bridge Crane Rails and Steel
  - Concrete Membrane Vault Basins – purchase and install
  - Gallery
- D. Internal Mixed Liquor Return (IMLR) Pumping
- IMLR Pump Equipment – purchase and install
  - 24" CS Pipe (4ea Pumps, 1/Cell, 300LF/EA)
  - Demolish Existing Pumps
  - Replace existing basin piping
- E. Return Activated Sludge (RAS) Pump
- *Not included in the scope for this alternative*
- F. Sidestream Anammox
- Sidestream Anammox – purchase and install
  - Pumps / Skimmer / Chains / Flight for Sedimentation Tank / Mixers – purchase and install
  - Centrate EQ Tank (60K gal) -purchase and install
  - Centrate Sedimentation Tank (60K gal) – purchase and install
  - Anammox Reactor Tanks (118.5K gal) – purchase and install
- G. Supplemental Methanol System
- Supplemental Methanol System (30K gal) – purchase and install
- H. Supplemental Alkalinity System
- *Not included in the scope for this alternative*
- I. Aeration Blowers
- Aeration Blowers – purchase and install
  - Aeration Blower Diffusers
- J. Aeration Basin Mixers for Anoxic Zones
- Aeration Basin Mixers – purchase and install
- K. Sidestream Bioaugmentation
- *Not included in the scope for this alternative*
- L. Tertiary Pumps
- Tertiary Pump – purchase and install
  - Tertiary Pumphouse / Electric Bldg. – purchase and install
  - Tertiary Wet Well – purchase and install
  - Tertiary Wet Well Baffle Walls – purchase and install
- M. Tertiary Fixed Film System
- Tertiary Fixed-Film System – purchase and install
  - Fixed Film Vault Basin (6 cell)
  - Fixed Film Vault Basins (Interior Walls)

## BASIS OF ESTIMATE

Project Name	<b>Brightwater Treatment Plant Nitrogen Removal - Alternative 2C</b>		
Project Number:		Date:	April 28, 2020

- N. Aeration / MBR Odor Control
  - New Odor Control Facility – purchase and install
  - Extend and Connect Foul Air Ductwork to the Aeration Basins, Side-Stream and Membrane Basins
  - HDPE buried foul air ductwork
- O. Primary Clarifier / Aerated Grit Tank
  - Grit Tank – purchase and install
- P. Miscellaneous Scope
  - Backwash waste to grit tank
  - Centrate to side-stream anammox
  - Anammox effluent to grit tank
  - 24" CS ML pipe from aeration basin to membrane basin
  - ME to tertiary feed pump station
  - Tertiary effluent to disinfection station
  - Methanol to aeration basin and tertiary basin
  - Force mains
  - New rerouted roadway
  - Retaining wall

### 3.0 Design Basis

---

This is an AACE International Class 5 estimate with all required documentation. The estimate is based on engineering deliverables, scoping documentation, discussions with the project team, and all supporting information and documentation provided in December 2019 thru April 2020.

Engineering conceptual scope was provided in the following estimating deliverables. These are the most complete scoping documents that were available to the estimating provider.

Engineering and Estimating Deliverables provided include:

- Brown and Caldwell Layout, Brightwater Nitrogen Removal Study, 7ea. Alternative Marked Up Sketches, (Alt.1/2A/2B/2C/3A/3B/3C), undated
- Brown and Caldwell, Tertiary Feed Pump Station Wetwell layout, Alt. 2C/3C, undated.
- Brown and Caldwell, BW Nitrogen Removal Alt. Cost Estimating Alt1/2A/2B/2C/3A/3B/3C, v0, undated
- KC, WPTP, Aeration Basin Plan View, dated: 01.18.2010
- KC, WPTP, Aeration Basin 2ea Sketch SND Alt.1, dated: 09.05.2013
- KC, WPTP, Aeration Basin 2ea Sketch SND Alt. 2A/3A, dated: 09.05.2013
- KC, WPTP, Aeration Basin 2ea Sketch MLE Alt. 2B/2C/3C, dated: 09.05.2013
- KC, WPTP, Aeration Basin 2ea Sketch 4SMB Alt. 3B, dated: 09.05.2013
- Estimation of MBR as final construction cost of Brightwater, dated: 12.11.2019
- Membrane Tanks 9 and 10 Estimate, Eric Benton, dated: 01.05.2018
- New Aeration Basin, East blower Room and Anoxic Basin Estimate, Eric Benton, dated: 02.06.2018
- Veolia, Biostyr Example Drawings 5ea, dated: 02.27.2019
- BW – YP – SD Model All Yard Piping, undated PDF
- KC WTD, BWTP Vol.11, General Sheets and Legends, Record Drawings, dated: Nov. 2012
- KC WTD, BWTP Vol. 12, Process and Instrumentation Diagrams, dated: 2013

## BASIS OF ESTIMATE

Project Name	<b>Brightwater Treatment Plant Nitrogen Removal - Alternative 2C</b>		
Project Number:		Date:	April 28, 2020

- KC WTD, BWTP Vol. 22, Mechanical Area 510 Aeration Basins, dated: 2013
- KC WTD, BWTP Vol. 22, Structural Area 510 Aeration Basins, dated: 2013
- KC WTD, BWTP Vol. 23, Mechanical Area 520 Membrane Basins, dated: 2013
- KC WTD, BWTP Vol. 23, Structural Area 520 Membrane Basins, dated: 2013
- KC WTD. BWTP Vol. 16 Headworks Package
- KC WTD. BWTP Vol. 17 Grit Package
- KC WTD. BWTP Vol. 18 Headworks Truck Loadout Package
- KC WTD. BWTP Vol. 19 Primaries Package
- KC WTD. BWTP Vol. 20 PE Screens Package
- KC WTD. BWTP Vol. 21 HW Prim Odor Control Package
- KC WTD. BWTP Vol. 24 Aer MBR Odor Control Package
- KC WTD. BWTP Vol. 25 Disinfection Package
- KC WTD. BWTP Vol. 26 Chem Storage Package
- KC WTD. BWTP Vol. 27 Solids Bldg. Package
- Brightwater Anammox Cap Cost Assumptions
- KC WTD, Aeration Basin #4 RAS Anoxic Basin and Side Stream BOE, dated: 02.18.2018
- KC WTD, BW Membrane Cassettes 9 and 10 BOE, dated: 02.09.2018
- Brightwater Nitrogen Removal Alternatives – Cost Estimating Assumptions V2, undated.

### Equipment Quotes:

- Next Turbo Budget Quote, Aeration Blowers, dated: 10.25.2019
- Suez Budget Quote, MBR, dated: 10.21.2019
- Ovivo Budget Quote, Sidestream Anammox, dated: 12.18.2019
- Biostyr Budget Quote, Tertiary, dated: 12.19.2019
- Fairbanks Quotation Curve, IMLR Pumps, undated.
- Fairbanks Quotation Curve, Tertiary Feed Pumps, undated.

## 4.0 Planning Basis

---

The following planning basis assumptions were made for the project estimate:

- No project construction plan is in place at this time.
- The assumed execution strategy is a standard workweek with limited overtime.
- No unusual site conditions have been considered as part of this estimate.
- Adequate available power exists at the site.

## 5.0 Cost Basis

---

- All allied and indirect project costs (allowances for indeterminates, change order allowance, engineering, permitting, WTD staffing, etc.) have been estimated using WTD's PRISM cost model which is baselined to historical project costs.
- The estimate was performed based on drawings, sketches, and project information provided by King County and Brown and Caldwell Engineers.
- WTD is using a PRISM cost model dated January 26, 2017. All Allied and indirect project costs have been estimated using the new WTD PRISM cost model baselined to historical project costs.

## BASIS OF ESTIMATE

Project Name	<b>Brightwater Treatment Plant Nitrogen Removal - Alternative 2C</b>		
Project Number:		Date:	April 28, 2020

- Additional technical project complexity factors for WTD indirect project costs have been introduced and incorporated into project allied costs to allow for development of an additional WTD indirect cost allowance, based upon the unique characteristics of the project.
- Equipment factors were developed utilizing historical data which accounts for specific install of the identified equipment within a normal battery limit. Specific scope relative to this project was used in the equipment factor determination. Factors for each specific type of equipment reflect the different complexity of the installation. Engineering supplied equipment costs were multiplied by the factors in order to estimate direct construction cost for the purchase and install of the equipment.
- Estimated costs incorporate prevailing King County wage rates.
- All costs were estimated in 1<sup>st</sup> Quarter 2020 dollars.

### 6.0 Allowances

---

The level and types of allowances used in the estimate is as follows (common percentages for each alternative are shown and any estimate-specific differences are indicated):

- Sales Tax was included as 10.1% applied to the base construction cost, including the design and change order contingencies.
- A 25% Allowance for Indeterminates (AFI) is applied to the base construction cost. The AFI is an allowance that accounts for the cost of known but undefined requirements necessary for a complete and workable project. The AFI accounts for elements that are not explicitly shown in the project documents to be further defined as part of the design development and project delivery process. The AFI is carried at 25% at conceptual design, based on the WTD project delivery process.
- Allowance of 10% for potential construction change orders.
- Allowance of 0.2% of the primary construction amount for miscellaneous direct capital costs.
- Allowance of 0.88% of the primary construction amount for permitting and other agency support.
- Allowance of 1.8% of the primary construction amount for miscellaneous services and material.
- Allowance of 0.65% of the primary construction amount for Non-WTD Support.
- Allowance of 1.0% of the primary construction amount for art initiatives.
- Allowance of 0.5% of the total project cost for sustainability.
- Allowance for application of total project contingency (see *Contingency* section below).
- Allowance of 0% was included for Escalation as the estimate is produced in current year (2020) dollars.
- Allowance of 18.35% of the primary construction amount for Engineering Services.
- Allowance of 7.88% of the primary construction amount for Construction Management Support
- Allowance of 12.37% of the primary construction amount for WTD staff labor and burden.
- No Escalation has been included.

## BASIS OF ESTIMATE

Project Name	<b>Brightwater Treatment Plant Nitrogen Removal - Alternative 2C</b>		
Project Number:		Date:	April 28, 2020

- Additional estimating allowances for WTD indirect costs of approximately \$22.01 million have been included in the Total Project Cost estimate by using a moderate degree of complexity rating for Design Engineering, Construction Management, Operations Support, and Project Management. Complexity factors were calibrated based on comments received from King County on March 04, 2020.
  - An allowance of \$17.45 million for Design and Construction Consulting
  - An allowance of \$0 million for Permitting & Other Agency Support
  - An allowance of \$4.56 million for WTD Staff Labor

### 7.0 Assumptions

---

Any other assumptions made by the estimator but not documented elsewhere in the estimate basis are included in this section.

- All costs included in the estimate reflect the best understanding of requirements as they existed at the time the estimates were prepared. Any modifications to the present scope and/or location of the project site may have substantial cost and schedule impacts.
- The engineering design will be performed by an external consultant engineer.
- Construction management will not be performed “in-house” by WTD. It will be performed by an external consultant construction manager.
- The project will generally align with the WTD PRISM cost model for Treatment projects.
- All work will always be performed utilizing safe work methods.
- Work will be sequenced to minimize standard process, service, and community interruptions. However, no costs are included to address sequencing necessary to keep the plant operational during construction.
- No costs are included for any new facilities that would be required, beyond the scope of this project to replace any lost capacity to the Brightwater Treatment Plant.
- It is assumed that the best improvement solution is included in the project scope(s).
- There will be some degree of productivity loss due to the site location. Some degree of productivity loss is included in the estimated costs. Any unusual site conditions are not accounted for in this estimate.
- Any additional work discovered during project implementation would need to be either a supplemental approval of added scope or be approved as an additional project.
- This project will be engineered to meet Washington State area seismic requirements.
- A degree of minimal cost rounding will occur during the normal estimating process.
- No allowance is included for Material Pricing Uncertainty.
- Power is readily available in the general area of this project. No new power sources are included in the scope of this project.

## **BASIS OF ESTIMATE**

Project Name	<b>Brightwater Treatment Plant Nitrogen Removal - Alternative 2C</b>		
Project Number:		Date:	April 28, 2020

- It is assumed that some general material contamination is present. The estimate covers minimal cost of removal wherever the contamination is disturbed during construction. This cost is covered in productivity rates utilized in the estimate.

### **8.0 Exclusions**

---

All potential items of cost which might be associated with the project but for which no costs have been included are listed below:

- No asbestos removal costs are included.
- No estimated costs are included for any potential delays due to interferences.
- No costs are included for utility relocations.
- No costs are included for temporary construction easements.
- No costs are included for street use or street improvement permits.
- No costs are included for additional scope beyond that as detailed in the current scope of work.

### **9.0 Exceptions**

---

This estimate is classified as a King County Wastewater Treatment Division Class 5 estimate based on an AACE International Class 5 estimate, with no exceptions per the King County WTD project process, for the scope as known at the time of the estimate preparation.

### **10.0 Risks (Threats and Opportunities)**

---

At the time of estimate preparation, a formal risk analysis session had not been conducted. General potential risks are listed below.

- There is a risk that additional scope, technology advances or major deviation from the suggested project scope will adversely impact cost and schedule.
- Future unknown or changing site conditions present a risk around productivities, schedule, and costs.
- More stringent or completely new regulations, usage fees, permitting, or environmental impacts may result in risks that could adversely impact cost and schedule.
- Potential complex construction and constructability issues could arise during construction, resulting in major design/construction changes.
- The space constraints could significantly impact assumed productivities and crew sizes identified for the estimated concept, resulting in increased costs due to loss of production.
- The scheduled timing of project execution will greatly impact the bottom-line costs. There is risk related to labor availability and fluctuating commodity and equipment pricing in the timeframe between this early conceptual estimate and the actual execution of the project. Rising costs due to inflation, escalation and competing major worldwide projects pose the possibility of noticeable project cost and schedule increases.
- Weather conditions and emergency service interruptions present the possibility of negative schedule and cost impacts.



## **BASIS OF ESTIMATE**

Project Name	<b>Brightwater Treatment Plant Nitrogen Removal - Alternative 2C</b>		
Project Number:		Date:	April 28, 2020

- Any possible coordination with other agencies could result in potential impacts on costs, schedule and Project Definition process.
- There is a risk that stakeholders could oppose the proposed design or prefer a different approach or site to be selected, resulting in schedule delays and a higher cost alternative.

### **11.0 Contingency**

---

Contingency is a cost element of the estimate used to cover uncertainties and unforeseeable elements of cost within the defined project scope. Contingency covers inadequacies in project scope definition, estimating methods, and estimating data. Contingency specifically excludes changes in project scope, and unforeseen major events such as earthquakes, prolonged labor strikes, etc.

A 30% Project Contingency was added to the base estimate of Total Project Costs (direct and indirect) as a result of the project estimating process and in accordance with the King County WTD project delivery process.

The estimating analysis resulted in a project contingency of approximately \$104.9 million (US\$).

The total project cost at a 50% confidence level (P50) is typically used for funding and baselining of a project at this stage and level of engineering and project development. The P50 confidence level suggests that there is a 50% cumulative probability of project cost under-run (or 50% probability of exceedance) at this dollar amount for the presently defined and known project scope.

### **12.0 Management Reserve**

---

No allocation of costs was included in this estimate for Management Reserves.

Contingency is not intended to cover the costs for changes in project scope. If the project needs to provide an allowance for anticipated changes in scope or to cover the costs for items that may be required but have not yet been specifically identified as being included in the current project scope, then that amount of cost should be identified here.

### **13.0 Reconciliation**

---

Reconciliation was not conducted at this time.

### **14.0 Benchmarking**

---

All included Allied Costs as supplied by the PRISM historical database have been benchmarked against a similar portfolio of recently completed projects.

### **15.0 Estimate Quality Assurance Plan**

---

No reviews of total project costs have been conducted outside the reviews conducted within Brown and Caldwell and VMS estimating team. It is anticipated that upon completion of this estimate, reviews will happen between the estimate provider and WTD.

## BASIS OF ESTIMATE

Project Name	<b>Brightwater Treatment Plant Nitrogen Removal - Alternative 2C</b>		
Project Number:		Date:	April 28, 2020

### 16.0 Attachments

---

#### Attachment: Estimate Deliverables

Engineering and Estimating Deliverables provided include:

- Brown and Caldwell Layout, Brightwater Nitrogen Removal Study, 7ea. Alternative Marked Up Sketches, (Alt.1/2A/2B/2C/3A/3B/3C), undated
- Brown and Caldwell, Tertiary Feed Pump Station Wetwell layout, Alt. 2C/3C, undated.
- Brown and Caldwell, BW Nitrogen Removal Alt. Cost Estimating Alt1/2A/2B/2C/3A/3B/3C, v0, undated
- KC, WPTP, Aeration Basin Plan View, dated: 01.18.2010
- KC, WPTP, Aeration Basin 2ea Sketch SND Alt.1, dated: 09.05.2013
- KC, WPTP, Aeration Basin 2ea Sketch SND Alt. 2A/3A, dated: 09.05.2013
- KC, WPTP, Aeration Basin 2ea Sketch MLE Alt. 2B/2C/3C, dated: 09.05.2013
- KC, WPTP, Aeration Basin 2ea Sketch 4SMB Alt. 3B, dated: 09.05.2013
- Estimation of MBR as final construction cost of Brightwater, dated: 12.11.2019
- Membrane Tanks 9 and 10 Estimate, Eric Benton, dated: 01.05.2018
- New Aeration Basin, East blower Room and Anoxic Basin Estimate, Eric Benton, dated: 02.06.2018
- Veolia, Biostyr Example Drawings 5ea, dated: 02.27.2019
- BW – YP – SD Model All Yard Piping, undated PDF
- KC WTD, BWTP Vol.11, General Sheets and Legends, Record Drawings, dated: Nov. 2012
- KC WTD, BWTP Vol. 12, Process and Instrumentation Diagrams, dated: 2013
- KC WTD, BWTP Vol. 22, Mechanical Area 510 Aeration Basins, dated: 2013
- KC WTD, BWTP Vol. 22, Structural Area 510 Aeration Basins, dated: 2013
- KC WTD, BWTP Vol. 23, Mechanical Area 520 Membrane Basins, dated: 2013
- KC WTD, BWTP Vol. 23, Structural Area 520 Membrane Basins, dated: 2013
- KC WTD. BWTP Vol. 16 Headworks Package
- KC WTD. BWTP Vol. 17 Grit Package
- KC WTD. BWTP Vol. 18 Headworks Truck Loadout Package
- KC WTD. BWTP Vol. 19 Primaries Package
- KC WTD. BWTP Vol. 20 PE Screens Package
- KC WTD. BWTP Vol. 21 HW Prim Odor Control Package
- KC WTD. BWTP Vol. 24 Aer MBR Odor Control Package
- KC WTD. BWTP Vol. 25 Disinfection Package
- KC WTD. BWTP Vol. 26 Chem Storage Package
- KC WTD. BWTP Vol. 27 Solids Bldg. Package
- Brightwater Anammox Cap Cost Assumptions
- KC WTD, Aeration Basin #4 RAS Anoxic Basin and Side Stream BOE, dated: 02.18.2018
- KC WTD, BW Membrane Cassettes 9 and 10 BOE, dated: 02.09.2018
- Brightwater Nitrogen Removal Alternatives – Cost Estimating Assumptions V2, undated.

Equipment Quotes:

- Next Turbo Budget Quote, Aeration Blowers, dated: 10.25.2019
- Suez Budget Quote, MBR, dated: 10.21.2019
- Ovivo Budget Quote, Sidestream Anammox, dated: 12.18.2019

## BASIS OF ESTIMATE

Project Name	<b>Brightwater Treatment Plant Nitrogen Removal - Alternative 2C</b>		
Project Number:		Date:	April 28, 2020

- Biostyr Budget Quote, Tertiary, dated: 12.19.2019
- Fairbanks Quotation Curve, IMLR Pumps, undated.
- Fairbanks Quotation Curve, Tertiary Feed Pumps, undated.



# King County

Department of Natural Resources and Parks  
Wastewater Treatment Division

## Project Planning and Delivery Section

### BASIS OF ESTIMATE

---

Project Name	<b>Brightwater Treatment Plant Nitrogen Removal - Alternative 3A</b>
Project Number	
Date Prepared	April 29, 2020
Requested by	Tiffany Knapp, King County WTD
Prepared by	Douglas W. Leo, CCP, CEP, FRICS, FAACE Hon. Life, (VMS, Inc.)
Estimate Classification	WTD Class 5
Estimate Purpose	King County Class 5 Concept Screening
Estimate ID (Version)	6
Project Manager	Eron Jacobson, King County WTD
Project Control Engineer	
Cc or Distribution List	

*Note that the accuracy of the associated cost estimate is dependent upon the various underlying assumptions, inclusions, and exclusions described herein. Actual project costs may differ and can be significantly affected by factors such as changes in the external environment, the manner in which the project is executed and controlled, and other factors that may impact the estimate basis or otherwise affect the project. Estimate accuracy ranges are only assessments based upon the cost estimating methods and data employed in preparing the estimate and are not a guarantee of actual project costs.*

## **BASIS OF ESTIMATE**

Project Name	<b>Brightwater Treatment Plant Nitrogen Removal - Alternative 3A</b>		
Project Number:		Date:	April 29, 2020

### **1.0 Purpose**

---

The purpose of this estimate is to provide cost information to support King County's Brightwater Treatment Plant (BWTP) Flows and Loading Alternative Evaluation for the Nitrogen Removal Project. A series of alternatives have been developed for project evaluation to determine the best engineering and project cost solution.

This estimate was prepared to establish a King County Wastewater Treatment Division (WTD) pre-Class 5 conceptual cost estimate to provide order of magnitude cost to support WTD's capital project identification and budgeting process for Total Project Costs. The WTD pre-Class 5 estimate provides similar documentation to that of an AACE International Class 5 estimate. The range of anticipated project costs, per WTD estimating guidance, is -50% / +300%. The range of uncertainty is beyond that for a typical Class 5 estimate due to the scope being proximally defined with today's relative solutions and technologies to resolving the identified needs; when the projects move forward into capital delivery over the longer term, it is anticipated that many differences and changes may arise as the known and defined engineering solutions are developed.

Douglas Leo of Value Management Strategies, Inc. (VMS) prepared this Basis of Estimate in coordination with King County WTD, the Brown and Caldwell Engineers team, and the VMS estimating team after receiving scope information from WTD in December 2019 thru April 2020. This Basis of Estimate reflects VMS's best understanding of the estimating process for this project, as explained by King County WTD and Brown and Caldwell.

### **2.0 Project Scope Definition**

---

This estimate includes all investigation, administration/owners' costs, engineering and design, purchases, fabrications, installations, process certifications, permitting, community impacts, and miscellaneous costs not specifically excluded elsewhere in this document.

Comprehensive Total Field Costs are generated from historical allowances, sources such as WTD estimating tools, historical costs, and RS Means/VMS estimating databases. All supporting indirect costs were generated from the WTD PRISM historical database. All costs included in the estimate reflect the best understanding of requirements as they existed at the time this estimate was prepared.

The scope of BWTP Flows and Loading Alternative 3A is to provide SND/MBR and sidestream Anammox process, with the year-round nitrogen removal to 3-mg/L total inorganic nitrogen (TIN) equivalent. The scope was developed to a Conceptual Design level adequate to assess operations and maintenance issues, energy impacts, permitting and code compliance issues, constructability, estimated costs, and implementation schedule.

The Project Estimate was prepared utilizing the following Work Breakdown Structure (WBS) in order to provide clarity and transparency to the estimated costs. The scope as identified for the alternative is described below in accordance with the WBS. Details are based on the known and defined scope in the design documents provided. See section 3.0 for a detailed list of Design Documents.

- A. Primary Effluent (PE)
  - PE Screen – purchase and install
  - New PE Fines Screening Facility – purchase and install
- B. Aeration Basins
  - General
    - New Aeration Basin Trains – purchase and install
    - Baffle Wall in New Aeration Basin

## BASIS OF ESTIMATE

Project Name	<b>Brightwater Treatment Plant Nitrogen Removal - Alternative 3A</b>		
Project Number:		Date:	April 29, 2020

- Interior Basin Piping
- C. Membrane Basins
  - Membrane System (new cells) – purchase and install
  - Membrane System (retrofit cells) – purchase and install
  - MBR Bridge Crane Rails and Steel
  - Concrete Membrane Vault Basins – purchase and install
  - Gallery
- D. Internal Mixed Liquor Return (IMLR) Pumping
  - IMLR Pump Equipment – purchase and install
  - 36" CS Pipe per New Aeration Basin
  - Demolish Existing Pumps and Piping and Replace Pipe
- E. Return Activated Sludge (RAS) Pump
  - *Not included in the scope for this alternative*
- F. Sidestream Anammox
  - Sidestream Anammox – purchase and install
  - Pumps / Skimmer / Chains / Flight for Sedimentation Tank / Mixers – purchase and install
  - Centrate EQ Tank (60K gal) – purchase and install
  - Centrate Sedimentation Tank (60K gal) – purchase and install
  - Anammox Reactor Tanks (118.5K gal) – purchase and install
- G. Supplemental Methanol System
  - Supplemental Methanol System (15K gal) – purchase and install
- H. Supplemental Alkalinity System
  - *Not included in the scope for this alternative*
- I. Aeration Blowers
  - Aeration Blowers – purchase and install
  - Aeration Blower Diffusers
- J. Aeration Basin Mixers for Anoxic Zones
  - Aeration Basin Mixers – purchase and install
- K. Sidestream Bioaugmentation
  - *Not included in the scope for this alternative*
- L. Tertiary Pumps
  - *Not included in the scope for this alternative*
- M. Tertiary Fixed Film System
  - *Not included in the scope for this alternative*
- N. Aeration / MBR Odor Control
  - New Odor Control Facility – purchase and install
  - Extend and Connect Foul Air Ductwork to Aeration Basins, Side-Stream, and Membrane Basins
  - HDPE buried foul air ductwork
- O. Primary Clarifier / Aerated Grit Tank
  - Grit Tank – purchase and install
- P. Misc. Undefined Scope

## BASIS OF ESTIMATE

Project Name	<b>Brightwater Treatment Plant Nitrogen Removal - Alternative 3A</b>		
Project Number:		Date:	April 29, 2020

- Centrate to Sidestream Anammox – purchase and install
- Anammox Effluent to Grit Tank
- 36” and 72” CS ML Pipe from Aeration Basin to Membrane Basin
- Methanol to Aeration Basin and Tertiary Basin
- New Rerouted Roadway
- Retaining Wall on East Hillside and excavation is required

### 3.0 Design Basis

---

This is an AACE International Class 5 estimate with all required documentation. The estimate is based on engineering deliverables, scoping documentation, discussions with the project team, and all supporting information and documentation provided in December 2019 thru April 2020.

Engineering conceptual scope was provided in the following estimating deliverables. These are the most complete scoping documents that were available to the estimating provider.

Engineering and Estimating Deliverables provided include:

- Brown and Caldwell Layout, Brightwater Nitrogen Removal Study, 7ea. Alternative Marked Up Sketches, (Alt. 1/2A/2B/2C/3A/3B/3C), undated
- Brown and Caldwell, Tertiary Feed Pump Station Wetwell layout, Alt. 2C/3C, undated.
- Brown and Caldwell, BW Nitrogen Removal Alt. Cost Estimating Alt1/2A/2B/2C/3A/3B/3C, v0, undated
- KC, WPTP, Aeration Basin Plan View, dated: 01.18.2010
- KC, WPTP, Aeration Basin 2ea Sketch SND Alt.1, dated: 09.05.2013
- KC, WPTP, Aeration Basin 2ea Sketch SND Alt. 2A/3A, dated: 09.05.2013
- KC, WPTP, Aeration Basin 2ea Sketch MLE Alt. 2B/2C/3C, dated: 09.05.2013
- KC, WPTP, Aeration Basin 2ea Sketch 4SMB Alt. 3B, dated: 09.05.2013
- Estimation of MBR as final construction cost of Brightwater, dated: 12.11.2019
- Membrane Tanks 9 and 10 Estimate, Eric Benton, dated: 01.05.2018
- New Aeration Basin, East blower Room and Anoxic Basin Estimate, Eric Benton, dated: 02.06.2018
- Veolia, Biostyr Example Drawings 5ea, dated: 02.27.2019
- BW – YP – SD Model All Yard Piping, undated PDF
- KC WTD, BWTP Vol.11, General Sheets and Legends, Record Drawings, dated: Nov. 2012
- KC WTD, BWTP Vol. 12, Process and Instrumentation Diagrams, dated: 2013
- KC WTD, BWTP Vol. 22, Mechanical Area 510 Aeration Basins, dated: 2013
- KC WTD, BWTP Vol. 22, Structural Area 510 Aeration Basins, dated: 2013
- KC WTD, BWTP Vol. 23, Mechanical Area 520 Membrane Basins, dated: 2013
- KC WTD, BWTP Vol. 23, Structural Area 520 Membrane Basins, dated: 2013
- KC WTD. BWTP Vol. 16 Headworks Package
- KC WTD. BWTP Vol. 17 Grit Package
- KC WTD. BWTP Vol. 18 Headworks Truck Loadout Package
- KC WTD. BWTP Vol. 19 Primaries Package
- KC WTD. BWTP Vol. 20 PE Screens Package
- KC WTD. BWTP Vol. 21 HW Prim Odor Control Package
- KC WTD. BWTP Vol. 24 Aer MBR Odor Control Package
- KC WTD. BWTP Vol. 25 Disinfection Package
- KC WTD. BWTP Vol. 26 Chem Storage Package



## **BASIS OF ESTIMATE**

Project Name	<b>Brightwater Treatment Plant Nitrogen Removal - Alternative 3A</b>		
Project Number:		Date:	April 29, 2020

- KC WTD, BWTP Vol. 27 Solids Bldg. Package
- Brightwater Anammox Cap Cost Assumptions
- KC WTD, Aeration Basin #4 RAS Anoxic Basin and Side Stream BOE, dated: 02.18.2018
- KC WTD, BW Membrane Cassettes 9 and 10 BOE, dated: 02.09.2018
- Brightwater Nitrogen Removal Alternatives – Cost Estimating Assumptions V2, undated.

### Equipment Quotes:

- Next Turbo Budget Quote, Aeration Blowers, dated: 10.25.2019
- Suez Budget Quote, MBR, dated: 10.21.2019
- Ovivo Budget Quote, Sidestream Anammox, dated: 12.18.2019
- Biostyr Budget Quote, Tertiary, dated: 12.19.2019
- Fairbanks Quotation Curve, IMLR Pumps, undated.
- Fairbanks Quotation Curve, Tertiary Feed Pumps, undated.

## **4.0 Planning Basis**

---

The following planning basis assumptions were made for the project estimate:

- No project construction plan is in place at this time.
- The assumed execution strategy is a standard workweek with limited overtime.
- No unusual site conditions have been considered as part of this estimate.
- Adequate available power exists at the site.

## **5.0 Cost Basis**

---

- All allied and indirect project costs (allowances for indeterminates, change order allowance, engineering, permitting, WTD staffing, etc.) have been estimated using WTD's PRISM cost model which is baselined to historical project costs.
- The estimate was performed based on drawings, sketches, and project information provided by King County and Brown and Caldwell Engineers.
- WTD is using a PRISM cost model dated January 26, 2017. All Allied and indirect project costs have been estimated using the new WTD PRISM cost model baselined to historical project costs.
- Additional technical project complexity factors for WTD indirect project costs have been introduced and incorporated into project allied costs to allow for development of an additional WTD indirect cost allowance, based upon the unique characteristics of the project.
- Equipment factors were developed utilizing historical data which accounts for specific install of the identified equipment within a normal battery limit. Specific scope relative to this project was used in the equipment factor determination. Factors for each specific type of equipment reflect the different complexity of the installation. Engineering supplied equipment costs were multiplied by the factors in order to estimate direct construction cost for the purchase and install of the equipment.
- Estimated costs incorporate prevailing King County wage rates.

## BASIS OF ESTIMATE

Project Name	<b>Brightwater Treatment Plant Nitrogen Removal - Alternative 3A</b>		
Project Number:		Date:	April 29, 2020

- All costs were estimated in 1<sup>st</sup> Quarter 2020 dollars.

### 6.0 Allowances

---

The level and types of allowances used in the estimate is as follows (common percentages for each alternative are shown and any estimate-specific differences are indicated):

- Sales Tax was included as 10.1% applied to the base construction cost, including the design and change order contingencies.
- A 25% Allowance for Indeterminates (AFI) is applied to the base construction cost. The AFI is an allowance that accounts for the cost of known but undefined requirements necessary for a complete and workable project. The AFI accounts for elements that are not explicitly shown in the project documents to be further defined as part of the design development and project delivery process. The AFI is carried at 25% at conceptual design, based on the WTD project delivery process.
- Allowance of 10% for potential construction change orders.
- Allowance of 0.2% of the primary construction amount for miscellaneous direct capital costs.
- Allowance of 0.88% of the primary construction amount for permitting and other agency support.
- Allowance of 1.8% of the primary construction amount for miscellaneous services and material.
- Allowance of 0.65% of the primary construction amount for Non-WTD Support.
- Allowance of 1.0% of the primary construction amount for art initiatives.
- Allowance of 0.5% of the total project cost for sustainability.
- Allowance for application of total project contingency (see *Contingency* section below).
- Allowance of 0% was included for Escalation as the estimate is produced in current year (2020) dollars.
- Allowance of 18.6% of the primary construction amount for Engineering Services.
- Allowance of 8.03% of the primary construction amount for Construction Management Support
- Allowance of 12.48% of the primary construction amount for WTD staff labor and burden.
- No Escalation has been included.
- Additional estimating allowances for WTD indirect costs of approximately \$21.26 million have been included in the Total Project Cost estimate by using a moderate degree of complexity rating for Design Engineering, Construction Management, Permitting, Operations Support, and Project Management. Complexity factors were calibrated based on comments received from King County on March 04, 2020.
  - An allowance of \$16.27 million for Design and Construction Consulting
  - An allowance of \$0.77 million for Permitting & Other Agency Support
  - An allowance of \$4.22 million for WTD Staff Labor

## **BASIS OF ESTIMATE**

Project Name	<b>Brightwater Treatment Plant Nitrogen Removal - Alternative 3A</b>		
Project Number:		Date:	April 29, 2020

### **7.0 Assumptions**

---

Any other assumptions made by the estimator but not documented elsewhere in the estimate basis are included in this section.

- All costs included in the estimate reflect the best understanding of requirements as they existed at the time the estimates were prepared. Any modifications to the present scope and/or location of the project site may have substantial cost and schedule impacts.
- The engineering design will be performed by an external consultant engineer.
- Construction management will not be performed “in-house” by WTD. It will be performed by an external consultant construction manager.
- The project will generally align with the WTD PRISM cost model for Treatment projects.
- All work will always be performed utilizing safe work methods.
- Work will be sequenced to minimize standard process, service, and community interruptions. However, no costs are included to address sequencing necessary to keep the plant operational during construction.
- No costs are included for any new facilities that would be required, beyond the scope of this project to replace any lost capacity to the Brightwater Treatment Plant.
- It is assumed that the best improvement solution is included in the project scope(s).
- There will be some degree of productivity loss due to the site location. Some degree of productivity loss is included in the estimated costs. Any unusual site conditions are not accounted for in this estimate.
- Any additional work discovered during project implementation would need to be either a supplemental approval of added scope or be approved as an additional project.
- This project will be engineered to meet Washington State area seismic requirements.
- A degree of minimal cost rounding will occur during the normal estimating process.
- No allowance is included for Material Pricing Uncertainty.
- Power is readily available in the general area of this project. No new power sources are included in the scope of this project.
- It is assumed that some general material contamination is present. The estimate covers minimal cost of removal wherever the contamination is disturbed during construction. This cost is covered in productivity rates utilized in the estimate.

### **8.0 Exclusions**

---

All potential items of cost which might be associated with the project but for which no costs have been included are listed below:

- No asbestos removal costs are included.
- No estimated costs are included for any potential delays due to interferences.
- No costs are included for utility relocations.

## BASIS OF ESTIMATE

Project Name	<b>Brightwater Treatment Plant Nitrogen Removal - Alternative 3A</b>		
Project Number:		Date:	April 29, 2020

- No costs are included for temporary construction easements.
- No costs are included for street use or street improvement permits.
- No costs are included for additional scope beyond that as detailed in the current scope of work.

### 9.0 Exceptions

---

This estimate is classified as a King County Wastewater Treatment Division Class 5 estimate based on an AACE International Class 5 estimate, with no exceptions per the King County WTD project process, for the scope as known at the time of the estimate preparation.

### 10.0 Risks (Threats and Opportunities)

---

At the time of estimate preparation, a formal risk analysis session had not been conducted. General potential risks are listed below.

- There is a risk that additional scope, technology advances or major deviation from the suggested project scope will adversely impact cost and schedule.
- Future unknown or changing site conditions present a risk around productivities, schedule, and costs.
- More stringent or completely new regulations, usage fees, permitting, or environmental impacts may result in risks that could adversely impact cost and schedule.
- Potential complex construction and constructability issues could arise during construction, resulting in major design/construction changes.
- The space constraints could significantly impact assumed productivities and crew sizes identified for the estimated concept, resulting in increased costs due to loss of production.
- The scheduled timing of project execution will greatly impact the bottom-line costs. There is risk related to labor availability and fluctuating commodity and equipment pricing in the timeframe between this early conceptual estimate and the actual execution of the project. Rising costs due to inflation, escalation and competing major worldwide projects pose the possibility of noticeable project cost and schedule increases.
- Weather conditions and emergency service interruptions present the possibility of negative schedule and cost impacts.
- Any possible coordination with other agencies could result in potential impacts on costs, schedule and Project Definition process.
- There is a risk that stakeholders could oppose the proposed design or prefer a different approach or site to be selected, resulting in schedule delays and a higher cost alternative.

## **BASIS OF ESTIMATE**

Project Name	<b>Brightwater Treatment Plant Nitrogen Removal - Alternative 3A</b>		
Project Number:		Date:	April 29, 2020

### **11.0 Contingency**

---

Contingency is a cost element of the estimate used to cover uncertainties and unforeseeable elements of cost within the defined project scope. Contingency covers inadequacies in project scope definition, estimating methods, and estimating data. Contingency specifically excludes changes in project scope, and unforeseen major events such as earthquakes, prolonged labor strikes, etc.

A 30% Project Contingency was added to the base estimate of Total Project Costs (direct and indirect) as a result of the project estimating process and in accordance with the King County WTD project delivery process.

The estimating analysis resulted in a project contingency of approximately \$93.97 million (US\$).

The total project cost at a 50% confidence level (P50) is typically used for funding and baselining of a project at this stage and level of engineering and project development. The P50 confidence level suggests that there is a 50% cumulative probability of project cost under-run (or 50% probability of exceedance) at this dollar amount for the presently defined and known project scope.

### **12.0 Management Reserve**

---

No allocation of costs was included in this estimate for Management Reserves.

Contingency is not intended to cover the costs for changes in project scope. If the project needs to provide an allowance for anticipated changes in scope or to cover the costs for items that may be required but have not yet been specifically identified as being included in the current project scope, then that amount of cost should be identified here.

### **13.0 Reconciliation**

---

Reconciliation was not conducted at this time.

### **14.0 Benchmarking**

---

All included Allied Costs as supplied by the PRISM historical database have been benchmarked against a similar portfolio of recently completed projects.

### **15.0 Estimate Quality Assurance Plan**

---

No reviews of total project costs have been conducted outside the reviews conducted within Brown and Caldwell and VMS estimating team. It is anticipated that upon completion of this estimate, reviews will happen between the estimate provider and WTD.

### **16.0 Attachments**

---

#### **Attachment: Estimate Deliverables**

Engineering and Estimating Deliverables provided include:

- Brown and Caldwell Layout, Brightwater Nitrogen Removal Study, 7ea. Alternative Marked Up Sketches, (Alt. 1/2A/2B/2C/3A/3B/3C), undated
- Brown and Caldwell, Tertiary Feed Pump Station Wetwell layout, Alt. 2C/3C, undated.

## BASIS OF ESTIMATE

Project Name	<b>Brightwater Treatment Plant Nitrogen Removal - Alternative 3A</b>		
Project Number:		Date:	April 29, 2020

- Brown and Caldwell, BW Nitrogen Removal Alt. Cost Estimating Alt1/2A/2B/2C/3A/3B/3C, v0, undated
- KC, WPTP, Aeration Basin Plan View, dated: 01.18.2010
- KC, WPTP, Aeration Basin 2ea Sketch SND Alt.1, dated: 09.05.2013
- KC, WPTP, Aeration Basin 2ea Sketch SND Alt. 2A/3A, dated: 09.05.2013
- KC, WPTP, Aeration Basin 2ea Sketch MLE Alt. 2B/2C/3C, dated: 09.05.2013
- KC, WPTP, Aeration Basin 2ea Sketch 4SMB Alt. 3B, dated: 09.05.2013
- Estimation of MBR as final construction cost of Brightwater, dated: 12.11.2019
- Membrane Tanks 9 and 10 Estimate, Eric Benton, dated: 01.05.2018
- New Aeration Basin, East blower Room and Anoxic Basin Estimate, Eric Benton, dated: 02.06.2018
- Veolia, Biostyr Example Drawings 5ea, dated: 02.27.2019
- BW – YP – SD Model All Yard Piping, undated PDF
- KC WTD, BWTP Vol.11, General Sheets and Legends, Record Drawings, dated: Nov. 2012
- KC WTD, BWTP Vol. 12, Process and Instrumentation Diagrams, dated: 2013
- KC WTD, BWTP Vol. 22, Mechanical Area 510 Aeration Basins, dated: 2013
- KC WTD, BWTP Vol. 22, Structural Area 510 Aeration Basins, dated: 2013
- KC WTD, BWTP Vol. 23, Mechanical Area 520 Membrane Basins, dated: 2013
- KC WTD, BWTP Vol. 23, Structural Area 520 Membrane Basins, dated: 2013
- KC WTD. BWTP Vol. 16 Headworks Package
- KC WTD. BWTP Vol. 17 Grit Package
- KC WTD. BWTP Vol. 18 Headworks Truck Loadout Package
- KC WTD. BWTP Vol. 19 Primaries Package
- KC WTD. BWTP Vol. 20 PE Screens Package
- KC WTD. BWTP Vol. 21 HW Prim Odor Control Package
- KC WTD. BWTP Vol. 24 Aer MBR Odor Control Package
- KC WTD. BWTP Vol. 25 Disinfection Package
- KC WTD. BWTP Vol. 26 Chem Storage Package
- KC WTD. BWTP Vol. 27 Solids Bldg. Package
- Brightwater Anammox Cap Cost Assumptions
- KC WTD, Aeration Basin #4 RAS Anoxic Basin and Side Stream BOE, dated: 02.18.2018
- KC WTD, BW Membrane Cassettes 9 and 10 BOE, dated: 02.09.2018
- Brightwater Nitrogen Removal Alternatives – Cost Estimating Assumptions V2, undated.

### Equipment Quotes:

- Next Turbo Budget Quote, Aeration Blowers, dated: 10.25.2019
- Suez Budget Quote, MBR, dated: 10.21.2019
- Ovivo Budget Quote, Sidestream Anammox, dated: 12.18.2019
- Biostyr Budget Quote, Tertiary, dated: 12.19.2019
- Fairbanks Quotation Curve, IMLR Pumps, undated.
- Fairbanks Quotation Curve, Tertiary Feed Pumps, undated.



# King County

Department of Natural Resources and Parks  
Wastewater Treatment Division

## Project Planning and Delivery Section

### BASIS OF ESTIMATE

---

Project Name	<b>Brightwater Treatment Plant Nitrogen Removal - Alternative 3B</b>
Project Number	
Date Prepared	April 29, 2020
Requested by	Tiffany Knapp, King County WTD
Prepared by	Douglas W. Leo, CCP, CEP, FRICS, FAACE Hon. Life, (VMS, Inc.)
Estimate Classification	WTD Class 5
Estimate Purpose	King County Class 5 Concept Screening
Estimate ID (Version)	6
Project Manager	Eron Jacobson, King County WTD
Project Control Engineer	
Cc or Distribution List	

*Note that the accuracy of the associated cost estimate is dependent upon the various underlying assumptions, inclusions, and exclusions described herein. Actual project costs may differ and can be significantly affected by factors such as changes in the external environment, the manner in which the project is executed and controlled, and other factors that may impact the estimate basis or otherwise affect the project. Estimate accuracy ranges are only assessments based upon the cost estimating methods and data employed in preparing the estimate and are not a guarantee of actual project costs.*



## BASIS OF ESTIMATE

Project Name	<b>Brightwater Treatment Plant Nitrogen Removal - Alternative 3B</b>		
Project Number:		Date:	April 29, 2020

### 1.0 Purpose

---

The purpose of this estimate is to provide cost information to support King County's Brightwater Treatment Plant (BWTP) Flows and Loading Alternative Evaluation for the Nitrogen Removal Project. A series of alternatives have been developed for project evaluation to determine the best engineering and project cost solution.

This estimate was prepared to establish a King County Wastewater Treatment Division (WTD) pre-Class 5 conceptual cost estimate to provide order of magnitude cost to support WTD's capital project identification and budgeting process for Total Project Costs. The WTD pre-Class 5 estimate provides similar documentation to that of an AACE International Class 5 estimate. The range of anticipated project costs, per WTD estimating guidance, is -50% / +300%. The range of uncertainty is beyond that for a typical Class 5 estimate due to the scope being proximally defined with today's relative solutions and technologies to resolving the identified needs; when the projects move forward into capital delivery over the longer term, it is anticipated that many differences and changes may arise as the known and defined engineering solutions are developed.

Douglas Leo of Value Management Strategies, Inc. (VMS) prepared this Basis of Estimate in coordination with King County WTD, the Brown and Caldwell Engineers team, and the VMS estimating team after receiving scope information from WTD in December 2019 thru April 2020. This Basis of Estimate reflects VMS's best understanding of the estimating process for this project, as explained by King County WTD and Brown and Caldwell.

### 2.0 Project Scope Definition

---

This estimate includes all investigation, administration/owners' costs, engineering and design, purchases, fabrications, installations, process certifications, permitting, community impacts, and miscellaneous costs not specifically excluded elsewhere in this document.

Comprehensive Total Field Costs are generated from historical allowances, sources such as WTD estimating tools, historical costs, and RS Means/VMS estimating databases. All supporting indirect costs were generated from the WTD PRISM historical database. All costs included in the estimate reflect the best understanding of requirements as they existed at the time this estimate was prepared.

The scope BWTP Flows and Loading Alternative 3B is to provide 4SMB/MBR and sidestream Anammox process, with the year-round nitrogen removal to 3-mg/L total inorganic nitrogen (TIN) equivalent (4SMB/MBR and sidestream anammox). The scope was developed to a Conceptual Design level adequate to assess operations and maintenance issues, energy impacts, permitting and code compliance issues, constructability, estimated costs, and implementation schedule.

The Project Estimate was prepared utilizing the following Work Breakdown Structure (WBS) in order to provide clarity and transparency to the estimated costs. The scope as identified for the alternative is described below in accordance with the WBS. Details are based on the known and defined scope in the design documents provided. See section 3.0 for a detailed list of Design Documents.

- A. Primary Effluent (PE)
  - PE Screen – purchase and install
  - New PE Fine Screening Facility – purchase and install
- B. Aeration Basins
  - General
    - New Aeration Basin – purchase and install

## BASIS OF ESTIMATE

Project Name	<b>Brightwater Treatment Plant Nitrogen Removal - Alternative 3B</b>		
Project Number:		Date:	April 29, 2020

- Baffle Wall in New Aeration Basin
  - Baffle Walls in Existing Aeration Basin
  - Interior Basin Piping
- C. Membrane Basins
- Membrane System (new cells) – purchase and install
  - Membrane System (retrofit cells) – purchase and install
  - MBR Bridge Crane Rails and Steel
  - Concrete Membrane Vault Basins – purchase and install
  - Gallery
- D. Internal Mixed Liquor Return (IMLR) Pumping
- IMLR Pump Equipment – purchase and install
  - 42" CS Pipe (10ea pumps, 2/cells, 200 LF/ea)
  - Demo Existing Pumps
  - Replace Existing Basin Piping
- E. Return Activated Sludge (RAS) Pump
- *Not included in the scope for this alternative*
- F. Sidestream Anammox
- Sidestream Anammox – purchase and install
  - Pumps / Skimmer / Chains / Flight for Sedimentation Tank / Mixers – purchase and install
  - Centrate EQ Tank (60K gal) – purchase and install
  - Centrate Sedimentation Tank (60K gal) – purchase and install
  - Anammox Reactor Tanks (118.5K gal) – purchase and install
- G. Supplemental Methanol System
- Supplemental Methanol System (15K gal) – purchase and install
- H. Supplemental Alkalinity System
- *Not included in the scope for this alternative*
- I. Aeration Blowers
- Aeration Blowers – purchase and install
  - Aeration Blower Diffusers
- J. Aeration Basin Mixers for Anoxic Zones
- Aeration Basin Mixers – purchase and install
- K. Sidestream Bioaugmentation
- *Not included in the scope for this alternative*
- L. Tertiary Pumps
- *Not included in the scope for this alternative*
- M. Tertiary Fixed Film System
- *Not included in the scope for this alternative*
- N. Aeration / MBR Odor Control
- New Odor Control Facility – purchase and install
  - Extend and Connect Foul Air Ductwork to Aeration Basins, Side-Stream, Membrane Basins
  - HDPE buried foul air ductwork
- O. Primary Clarifier / Aerated Grit Tank

## BASIS OF ESTIMATE

Project Name	<b>Brightwater Treatment Plant Nitrogen Removal - Alternative 3B</b>		
Project Number:		Date:	April 29, 2020

- Grit Tank – purchase and install
- P. Miscellaneous Scope
  - Centrate to Sidestream Anammox – purchase and install
  - Anammox Effluent to Grit Tank
  - 36” and 72” CS ML Pipe from Aeration Basin to Membrane Basin
  - Methanol to Aeration Basin and Tertiary Basin
  - New Rerouted Roadway
  - Retaining Wall on East Hillside and excavation is required

### 3.0 Design Basis

---

This is an AACE International Class 5 estimate with all required documentation. The estimate is based on engineering deliverables, scoping documentation, discussions with the project team, and all supporting information and documentation provided in December 2019 thru April 2020.

Engineering conceptual scope was provided in the following estimating deliverables. These are the most complete scoping documents that were available to the estimating provider.

Engineering and Estimating Deliverables provided include:

- Brown and Caldwell Layout, Brightwater Nitrogen Removal Study, 7ea. Alternative Marked Up Sketches, (Alt. 1/2A/2B/2C/3A/3B/3C), undated
- Brown and Caldwell, Tertiary Feed Pump Station Wetwell layout, Alt. 2C/3C, undated.
- Brown and Caldwell, BW Nitrogen Removal Alt. Cost Estimating Alt1/2A/2B/2C/3A/3B/3C, v0, undated
- KC, WPTP, Aeration Basin Plan View, dated: 01.18.2010
- KC, WPTP, Aeration Basin 2ea Sketch SND Alt.1, dated: 09.05.2013
- KC, WPTP, Aeration Basin 2ea Sketch SND Alt. 2A/3A, dated: 09.05.2013
- KC, WPTP, Aeration Basin 2ea Sketch MLE Alt. 2B/2C/3C, dated: 09.05.2013
- KC, WPTP, Aeration Basin 2ea Sketch 4SMB Alt. 3B, dated: 09.05.2013
- Estimation of MBR as final construction cost of Brightwater, dated: 12.11.2019
- Membrane Tanks 9 and 10 Estimate, Eric Benton, dated: 01.05.2018
- New Aeration Basin, East blower Room and Anoxic Basin Estimate, Eric Benton, dated: 02.06.2018
- Veolia, Biostyr Example Drawings 5ea, dated: 02.27.2019
- BW – YP – SD Model All Yard Piping, undated PDF
- KC WTD, BWTP Vol.11, General Sheets and Legends, Record Drawings, dated: Nov. 2012
- KC WTD, BWTP Vol. 12, Process and Instrumentation Diagrams, dated: 2013
- KC WTD, BWTP Vol. 22, Mechanical Area 510 Aeration Basins, dated: 2013
- KC WTD, BWTP Vol. 22, Structural Area 510 Aeration Basins, dated: 2013
- KC WTD, BWTP Vol. 23, Mechanical Area 520 Membrane Basins, dated: 2013
- KC WTD, BWTP Vol. 23, Structural Area 520 Membrane Basins, dated: 2013
- KC WTD. BWTP Vol. 16 Headworks Package
- KC WTD. BWTP Vol. 17 Grit Package
- KC WTD. BWTP Vol. 18 Headworks Truck Loadout Package
- KC WTD. BWTP Vol. 19 Primaries Package
- KC WTD. BWTP Vol. 20 PE Screens Package
- KC WTD. BWTP Vol. 21 HW Prim Odor Control Package

## BASIS OF ESTIMATE

Project Name	<b>Brightwater Treatment Plant Nitrogen Removal - Alternative 3B</b>		
Project Number:		Date:	April 29, 2020

- KC WTD. BWTP Vol. 24 Aer MBR Odor Control Package
- KC WTD. BWTP Vol. 25 Disinfection Package
- KC WTD. BWTP Vol. 26 Chem Storage Package
- KC WTD. BWTP Vol. 27 Solids Bldg. Package
- Brightwater Anammox Cap Cost Assumptions
- KC WTD, Aeration Basin #4 RAS Anoxic Basin and Side Stream BOE, dated: 02.18.2018
- KC WTD, BW Membrane Cassettes 9 and 10 BOE, dated: 02.09.2018
- Brightwater Nitrogen Removal Alternatives – Cost Estimating Assumptions V2, undated.

### Equipment Quotes:

- Next Turbo Budget Quote, Aeration Blowers, dated: 10.25.2019
- Suez Budget Quote, MBR, dated: 10.21.2019
- Ovivo Budget Quote, Sidestream Anammox, dated: 12.18.2019
- Biostyr Budget Quote, Tertiary, dated: 12.19.2019
- Fairbanks Quotation Curve, IMLR Pumps, undated.
- Fairbanks Quotation Curve, Tertiary Feed Pumps, undated.

## 4.0 Planning Basis

---

The following planning basis assumptions were made for the project estimate:

- No project construction plan is in place at this time.
- The assumed execution strategy is a standard workweek with limited overtime.
- No unusual site conditions have been considered as part of this estimate.
- Adequate available power exists at the site.

## 5.0 Cost Basis

---

- All allied and indirect project costs (allowances for indeterminates, change order allowance, engineering, permitting, WTD staffing, etc.) have been estimated using WTD's PRISM cost model which is baselined to historical project costs.
- The estimate was performed based on drawings, sketches, and project information provided by King County and Brown and Caldwell Engineers.
- WTD is using a PRISM cost model dated January 26, 2017. All Allied and indirect project costs have been estimated using the new WTD PRISM cost model baselined to historical project costs.
- Additional technical project complexity factors for WTD indirect project costs have been introduced and incorporated into project allied costs to allow for development of an additional WTD indirect cost allowance, based upon the unique characteristics of the project.
- Equipment factors were developed utilizing historical data which accounts for specific install of the identified equipment within a normal battery limit. Specific scope relative to this project was used in the equipment factor determination. Factors for each specific type of equipment reflect the different complexity of the installation. Engineering supplied equipment costs were multiplied

## BASIS OF ESTIMATE

Project Name	<b>Brightwater Treatment Plant Nitrogen Removal - Alternative 3B</b>		
Project Number:		Date:	April 29, 2020

by the factors in order to estimate direct construction cost for the purchase and install of the equipment.

- Estimated costs incorporate prevailing King County wage rates.
- All costs were estimated in 1<sup>st</sup> Quarter 2020 dollars.

### 6.0 Allowances

---

The level and types of allowances used in the estimate is as follows (common percentages for each alternative are shown and any estimate-specific differences are indicated):

- Sales Tax was included as 10.1% applied to the base construction cost, including the design and change order contingencies.
- A 25% Allowance for Indeterminates (AFI) is applied to the base construction cost. The AFI is an allowance that accounts for the cost of known but undefined requirements necessary for a complete and workable project. The AFI accounts for elements that are not explicitly shown in the project documents to be further defined as part of the design development and project delivery process. The AFI is carried at 25% at conceptual design, based on the WTD project delivery process.
- Allowance of 10% for potential construction change orders.
- Allowance of 0.2% of the primary construction amount for miscellaneous direct capital costs.
- Allowance of 0.88% of the primary construction amount for permitting and other agency support.
- Allowance of 1.8% of the primary construction amount for miscellaneous services and material.
- Allowance of 0.65% of the primary construction amount for Non-WTD Support.
- Allowance of 1.0% of the primary construction amount for art initiatives.
- Allowance of 0.5% of the total project cost for sustainability.
- Allowance for application of total project contingency (see *Contingency* section below).
- Allowance of 0% was included for Escalation as the estimate is produced in current year (2020) dollars.
- Allowance of 18.62% of the primary construction amount for Engineering Services.
- Allowance of 8.04% of the primary construction amount for Construction Management Support
- Allowance of 12.49% of the primary construction amount for WTD staff labor and burden.
- No Escalation has been included.
- Additional estimating allowances for WTD indirect costs of approximately \$21.09 million have been included in the Total Project Cost estimate by using a moderate degree of complexity rating for Design Engineering, Construction Management, Permitting, Operations Support, and Project Management. Complexity factors were calibrated based on comments received from King County on March 04, 2020.
  - An allowance of \$16.15 million for Design and Construction Consulting

## BASIS OF ESTIMATE

Project Name	<b>Brightwater Treatment Plant Nitrogen Removal - Alternative 3B</b>		
Project Number:		Date:	April 29, 2020

- An allowance of \$0.76 million for Permitting & Other Agency Support
- An allowance of \$4.19 million for WTD Staff Labor

### 7.0 Assumptions

---

Any other assumptions made by the estimator but not documented elsewhere in the estimate basis are included in this section.

- All costs included in the estimate reflect the best understanding of requirements as they existed at the time the estimates were prepared. Any modifications to the present scope and/or location of the project site may have substantial cost and schedule impacts.
- The engineering design will be performed by an external consultant engineer.
- Construction management will not be performed “in-house” by WTD. It will be performed by an external consultant construction manager.
- The project will generally align with the WTD PRISM cost model for Treatment projects.
- All work will always be performed utilizing safe work methods.
- Work will be sequenced to minimize standard process, service, and community interruptions. However, no costs are included to address sequencing necessary to keep the plant operational during construction.
- No costs are included for any new facilities that would be required, beyond the scope of this project to replace any lost capacity to the Brightwater Treatment Plant.
- It is assumed that the best improvement solution is included in the project scope(s).
- There will be some degree of productivity loss due to the site location. Some degree of productivity loss is included in the estimated costs. Any unusual site conditions are not accounted for in this estimate.
- Any additional work discovered during project implementation would need to be either a supplemental approval of added scope or be approved as an additional project.
- This project will be engineered to meet Washington State area seismic requirements.
- A degree of minimal cost rounding will occur during the normal estimating process.
- No allowance is included for Material Pricing Uncertainty.
- Power is readily available in the general area of this project. No new power sources are included in the scope of this project.
- It is assumed that some general material contamination is present. The estimate covers minimal cost of removal wherever the contamination is disturbed during construction. This cost is covered in productivity rates utilized in the estimate.

### 8.0 Exclusions

---

All potential items of cost which might be associated with the project but for which no costs have been included are listed below:

- No asbestos removal costs are included.

## BASIS OF ESTIMATE

Project Name	<b>Brightwater Treatment Plant Nitrogen Removal - Alternative 3B</b>		
Project Number:		Date:	April 29, 2020

- No estimated costs are included for any potential delays due to interferences.
- No costs are included for utility relocations.
- No costs are included for temporary construction easements.
- No costs are included for street use or street improvement permits.
- No costs are included for additional scope beyond that as detailed in the current scope of work.

### 9.0 Exceptions

---

This estimate is classified as a King County Wastewater Treatment Division Class 5 estimate based on an AACE International Class 5 estimate, with no exceptions per the King County WTD project process, for the scope as known at the time of the estimate preparation.

### 10.0 Risks (Threats and Opportunities)

---

At the time of estimate preparation, a formal risk analysis session had not been conducted. General potential risks are listed below.

- There is a risk that additional scope, technology advances or major deviation from the suggested project scope will adversely impact cost and schedule.
- Future unknown or changing site conditions present a risk around productivities, schedule, and costs.
- More stringent or completely new regulations, usage fees, permitting, or environmental impacts may result in risks that could adversely impact cost and schedule.
- Potential complex construction and constructability issues could arise during construction, resulting in major design/construction changes.
- The space constraints could significantly impact assumed productivities and crew sizes identified for the estimated concept, resulting in increased costs due to loss of production.
- The scheduled timing of project execution will greatly impact the bottom-line costs. There is risk related to labor availability and fluctuating commodity and equipment pricing in the timeframe between this early conceptual estimate and the actual execution of the project. Rising costs due to inflation, escalation and competing major worldwide projects pose the possibility of noticeable project cost and schedule increases.
- Weather conditions and emergency service interruptions present the possibility of negative schedule and cost impacts.
- Any possible coordination with other agencies could result in potential impacts on costs, schedule and Project Definition process.
- There is a risk that stakeholders could oppose the proposed design or prefer a different approach or site to be selected, resulting in schedule delays and a higher cost alternative.



## **BASIS OF ESTIMATE**

Project Name	<b>Brightwater Treatment Plant Nitrogen Removal - Alternative 3B</b>		
Project Number:		Date:	April 29, 2020

### **11.0 Contingency**

---

Contingency is a cost element of the estimate used to cover uncertainties and unforeseeable elements of cost within the defined project scope. Contingency covers inadequacies in project scope definition, estimating methods, and estimating data. Contingency specifically excludes changes in project scope, and unforeseen major events such as earthquakes, prolonged labor strikes, etc.

A 30% Project Contingency was added to the base estimate of Total Project Costs (direct and indirect) as a result of the project estimating process and in accordance with the King County WTD project delivery process.

The estimating analysis resulted in a project contingency of approximately \$93.13 million (US\$).

The total project cost at a 50% confidence level (P50) is typically used for funding and baselining of a project at this stage and level of engineering and project development. The P50 confidence level suggests that there is a 50% cumulative probability of project cost under-run (or 50% probability of exceedance) at this dollar amount for the presently defined and known project scope.

### **12.0 Management Reserve**

---

No allocation of costs was included in this estimate for Management Reserves.

Contingency is not intended to cover the costs for changes in project scope. If the project needs to provide an allowance for anticipated changes in scope or to cover the costs for items that may be required but have not yet been specifically identified as being included in the current project scope, then that amount of cost should be identified here.

### **13.0 Reconciliation**

---

Reconciliation was not conducted at this time.

### **14.0 Benchmarking**

---

All included Allied Costs as supplied by the PRISM historical database have been benchmarked against a similar portfolio of recently completed projects.

### **15.0 Estimate Quality Assurance Plan**

---

No reviews of total project costs have been conducted outside the reviews conducted within Brown and Caldwell and VMS estimating team. It is anticipated that upon completion of this estimate, reviews will happen between the estimate provider and WTD.

### **16.0 Attachments**

---

#### **Attachment: Estimate Deliverables**

Engineering and Estimating Deliverables provided include:

- Brown and Caldwell Layout, Brightwater Nitrogen Removal Study, 7ea. Alternative Marked Up Sketches, (Alt. 1/2A/2B/2C/3A/3B/3C), undated
- Brown and Caldwell, Tertiary Feed Pump Station Wetwell layout, Alt. 2C/3C, undated.

## BASIS OF ESTIMATE

Project Name	<b>Brightwater Treatment Plant Nitrogen Removal - Alternative 3B</b>		
Project Number:		Date:	April 29, 2020

- Brown and Caldwell, BW Nitrogen Removal Alt. Cost Estimating Alt1/2A/2B/2C/3A/3B/3C, v0, undated
- KC, WPTP, Aeration Basin Plan View, dated: 01.18.2010
- KC, WPTP, Aeration Basin 2ea Sketch SND Alt.1, dated: 09.05.2013
- KC, WPTP, Aeration Basin 2ea Sketch SND Alt. 2A/3A, dated: 09.05.2013
- KC, WPTP, Aeration Basin 2ea Sketch MLE Alt. 2B/2C/3C, dated: 09.05.2013
- KC, WPTP, Aeration Basin 2ea Sketch 4SMB Alt. 3B, dated: 09.05.2013
- Estimation of MBR as final construction cost of Brightwater, dated: 12.11.2019
- Membrane Tanks 9 and 10 Estimate, Eric Benton, dated: 01.05.2018
- New Aeration Basin, East blower Room and Anoxic Basin Estimate, Eric Benton, dated: 02.06.2018
- Veolia, Biostyr Example Drawings 5ea, dated: 02.27.2019
- BW – YP – SD Model All Yard Piping, undated PDF
- KC WTD, BWTP Vol.11, General Sheets and Legends, Record Drawings, dated: Nov. 2012
- KC WTD, BWTP Vol. 12, Process and Instrumentation Diagrams, dated: 2013
- KC WTD, BWTP Vol. 22, Mechanical Area 510 Aeration Basins, dated: 2013
- KC WTD, BWTP Vol. 22, Structural Area 510 Aeration Basins, dated: 2013
- KC WTD, BWTP Vol. 23, Mechanical Area 520 Membrane Basins, dated: 2013
- KC WTD, BWTP Vol. 23, Structural Area 520 Membrane Basins, dated: 2013
- KC WTD. BWTP Vol. 16 Headworks Package
- KC WTD. BWTP Vol. 17 Grit Package
- KC WTD. BWTP Vol. 18 Headworks Truck Loadout Package
- KC WTD. BWTP Vol. 19 Primaries Package
- KC WTD. BWTP Vol. 20 PE Screens Package
- KC WTD. BWTP Vol. 21 HW Prim Odor Control Package
- KC WTD. BWTP Vol. 24 Aer MBR Odor Control Package
- KC WTD. BWTP Vol. 25 Disinfection Package
- KC WTD. BWTP Vol. 26 Chem Storage Package
- KC WTD. BWTP Vol. 27 Solids Bldg. Package
- Brightwater Anammox Cap Cost Assumptions
- KC WTD, Aeration Basin #4 RAS Anoxic Basin and Side Stream BOE, dated: 02.18.2018
- KC WTD, BW Membrane Cassettes 9 and 10 BOE, dated: 02.09.2018
- Brightwater Nitrogen Removal Alternatives – Cost Estimating Assumptions V2, undated.

### Equipment Quotes:

- Next Turbo Budget Quote, Aeration Blowers, dated: 10.25.2019
- Suez Budget Quote, MBR, dated: 10.21.2019
- Ovivo Budget Quote, Sidestream Anammox, dated: 12.18.2019
- Biostyr Budget Quote, Tertiary, dated: 12.19.2019
- Fairbanks Quotation Curve, IMLR Pumps, undated.
- Fairbanks Quotation Curve, Tertiary Feed Pumps, undated.



# King County

Department of Natural Resources and Parks  
Wastewater Treatment Division

## Project Planning and Delivery Section

### BASIS OF ESTIMATE

---

Project Name	<b>Brightwater Treatment Plant Nitrogen Removal - Alternative 3C</b>
Project Number	
Date Prepared	April 28, 2020
Requested by	Tiffany Knapp, King County WTD
Prepared by	Douglas W. Leo, CCP, CEP, FRICS, FAACE Hon. Life, (VMS, Inc.)
Estimate Classification	WTD Class 5
Estimate Purpose	King County Class 5 Concept Screening
Estimate ID (Version)	5
Project Manager	Eron Jacobson, King County WTD
Project Control Engineer	
Cc or Distribution List	

*Note that the accuracy of the associated cost estimate is dependent upon the various underlying assumptions, inclusions, and exclusions described herein. Actual project costs may differ and can be significantly affected by factors such as changes in the external environment, the manner in which the project is executed and controlled, and other factors that may impact the estimate basis or otherwise affect the project. Estimate accuracy ranges are only assessments based upon the cost estimating methods and data employed in preparing the estimate and are not a guarantee of actual project costs.*

## **BASIS OF ESTIMATE**

Project Name	<b>Brightwater Treatment Plant Nitrogen Removal - Alternative 3C</b>		
Project Number:		Date:	April 28, 2020

### **1.0 Purpose**

---

The purpose of this estimate is to provide cost information to support King County's Brightwater Treatment Plant (BWTP) Flows and Loading Alternative Evaluation for the Nitrogen Removal Project. A series of alternatives have been developed for project evaluation to determine the best engineering and project cost solution.

This estimate was prepared to establish a King County Wastewater Treatment Division (WTD) pre-Class 5 conceptual cost estimate to provide order of magnitude cost to support WTD's capital project identification and budgeting process for Total Project Costs. The WTD pre-Class 5 estimate provides similar documentation to that of an AACE International Class 5 estimate. The range of anticipated project costs, per WTD estimating guidance, is -50% / +300%. The range of uncertainty is beyond that for a typical Class 5 estimate due to the scope being proximally defined with today's relative solutions and technologies to resolving the identified needs; when the projects move forward into capital delivery over the longer term, it is anticipated that many differences and changes may arise as the known and defined engineering solutions are developed.

Douglas Leo of Value Management Strategies, Inc. (VMS) prepared this Basis of Estimate in coordination with King County WTD, the Brown and Caldwell Engineers team, and the VMS estimating team after receiving scope information from WTD in December 2019 thru April 2020. This Basis of Estimate reflects VMS's best understanding of the estimating process for this project, as explained by King County WTD and Brown and Caldwell.

### **2.0 Project Scope Definition**

---

This estimate includes all investigation, administration/owners' costs, engineering and design, purchases, fabrications, installations, process certifications, permitting, community impacts, and miscellaneous costs not specifically excluded elsewhere in this document.

Comprehensive Total Field Costs are generated from historical allowances, sources such as WTD estimating tools, historical costs, and RS Means/VMS estimating databases. All supporting indirect costs were generated from the WTD PRISM historical database. All costs included in the estimate reflect the best understanding of requirements as they existed at the time this estimate was prepared.

The scope of BWTP Flows and Loading Alternative 3C is to provide MLE/MBR, Tertiary Denitrifying Fixed-Film and sidestream anammox process, with the year-round nitrogen removal to 3-mg/L total inorganic nitrogen (TIN) equivalent. The scope was developed to a Conceptual Design level adequate to assess operations and maintenance issues, energy impacts, permitting and code compliance issues, constructability, estimated costs, and implementation schedule.

The Project Estimate was prepared utilizing the following Work Breakdown Structure (WBS) in order to provide clarity and transparency to the estimated costs. The scope as identified for the alternative is described below in accordance with the WBS. Details are based on the known and defined scope in the design documents provided. See section 3.0 for a detailed list of Design Documents.

- A. Primary Effluent (PE)
  - PE Screen – purchase and install
  - New PE Fine Screening Facility – purchase and install
- B. Aeration Basins
  - General
    - New Aeration Basin Trains – purchase and install
    - Baffle Wall in New Aeration Basin

## BASIS OF ESTIMATE

Project Name	<b>Brightwater Treatment Plant Nitrogen Removal - Alternative 3C</b>		
Project Number:		Date:	April 28, 2020

- Baffle Walls in Existing Aeration Basin
- Interior Basin Piping
- C. Membrane Basins
  - Membrane System (new cells) – purchase and install
  - Membrane System (retrofit cells) – purchase and install
  - MBR Bridge Crane Rails and Steel
  - Concrete Membrane Vault Basins – purchase and install
  - Gallery
- D. Internal Mixed Liquor Return (IMLR) Pumping
  - IMLR Pump Equipment – purchase and install
  - 24" CS Pipe (4ea pumps, 1/cell, 300LF/ea)
  - Demo Existing Pumps
  - Replace existing basin piping
- E. Return Activated Sludge (RAS) Pump
  - *Not included in the scope for this alternative*
- F. Sidestream Anammox
  - Sidestream Anammox – purchase and install
  - Pumps/skimmer / Chains / Flight for Sedimentation Tank / Mixers – purchase and install
  - Centrate EQ Tank (60K gal) – purchase and install
  - Centrate Sedimentation Tank (60K gal) – purchase and install
  - Anammox Reactor Tanks (118.5K gal) – purchase and install
- G. Supplemental Methanol System
  - Supplemental Methanol System (15K gal) – purchase and install
- H. Supplemental Alkalinity System
  - *Not included in the scope for this alternative*
- I. Aeration Blowers
  - Aeration Blowers – purchase and install
  - Aeration Blower Diffusers
- J. Aeration Basin Mixers for Anoxic Zones
  - Aeration Basin Mixers – purchase and install
- K. Sidestream Bioaugmentation
  - *Not included in the scope for this alternative*
- L. Tertiary Pumps
  - Tertiary Pump – purchase and install
  - Tertiary Pumphouse / Electric Bldg. – purchase and install
  - Tertiary Wet Well – purchase and install
  - Tertiary Wet Well Baffle Walls – purchase and install
- M. Tertiary Fixed Film System
  - Tertiary Fixed Film System – purchase and install
  - Fixed Film Vault Basins (8 cell) – purchase and install
  - Fixed Film Vault Basins (interior walls) – purchase and install
- N. Aeration / MBR Odor Control
  - New Odor Control Facility – purchase and install

## BASIS OF ESTIMATE

Project Name	<b>Brightwater Treatment Plant Nitrogen Removal - Alternative 3C</b>		
Project Number:		Date:	April 28, 2020

- Extend and Connect Foul Air Ductwork to Aeration Basins, Side-Stream, Membrane Basin
- HDPE buried four air ductwork
- O. Primary Clarifier / Aerated Grit Tank
  - Grit Tank – purchase and install
- P. Miscellaneous Scope
  - Backwash waste to grit tank
  - Centrate to Sidestream Anammox – purchase and install
  - Anammox effluent to grit tank
  - 36” and 72” CS ML pipe from aeration basin to membrane basin
  - ME to tertiary feed pump station
  - Tertiary effluent to disinfection station
  - Methanol to aeration basin and tertiary basin
  - Forced mains
  - New Rerouted Roadway
  - Retaining Wall

### 3.0 Design Basis

---

This is an AACE International Class 5 estimate with all required documentation. The estimate is based on engineering deliverables, scoping documentation, discussions with the project team, and all supporting information and documentation provided in December 2019 thru April 2020.

Engineering conceptual scope was provided in the following estimating deliverables. These are the most complete scoping documents that were available to the estimating provider.

Engineering and Estimating Deliverables provided include:

- Brown and Caldwell Layout, Brightwater Nitrogen Removal Study, 7ea. Alternative Marked Up Sketches, (Alt.1/2A/2B/2C/3A/3B/3C), undated
- Brown and Caldwell, Tertiary Feed Pump Station Wetwell layout, Alt. 2C/3C, undated.
- Brown and Caldwell, BW Nitrogen Removal Alt. Cost Estimating Alt1/2A/2B/2C/3A/3B/3C, v0, undated
- KC, WPTP, Aeration Basin Plan View, dated: 01.18.2010
- KC, WPTP, Aeration Basin 2ea Sketch SND Alt.1, dated: 09.05.2013
- KC, WPTP, Aeration Basin 2ea Sketch SND Alt. 2A/3A, dated: 09.05.2013
- KC, WPTP, Aeration Basin 2ea Sketch MLE Alt. 2B/2C/3C, dated: 09.05.2013
- KC, WPTP, Aeration Basin 2ea Sketch 4SMB Alt. 3B, dated: 09.05.2013
- Estimation of MBR as final construction cost of Brightwater, dated: 12.11.2019
- Membrane Tanks 9 and 10 Estimate, Eric Benton, dated: 01.05.2018
- New Aeration Basin, East blower Room and Anoxic Basin Estimate, Eric Benton, dated: 02.06.2018
- Veolia, Biostyr Example Drawings 5ea, dated: 02.27.2019
- BW – YP – SD Model All Yard Piping, undated PDF
- KC WTD, BWTP Vol. 11, General Sheets and Legends, Record Drawings, dated: Nov. 2012
- KC WTD, BWTP Vol. 12, Process and Instrumentation Diagrams, dated: 2013
- KC WTD, BWTP Vol. 22, Mechanical Area 510 Aeration Basins, dated: 2013
- KC WTD, BWTP Vol. 22, Structural Area 510 Aeration Basins, dated: 2013
- KC WTD, BWTP Vol. 23, Mechanical Area 520 Membrane Basins, dated: 2013

## BASIS OF ESTIMATE

Project Name	<b>Brightwater Treatment Plant Nitrogen Removal - Alternative 3C</b>		
Project Number:		Date:	April 28, 2020

- KC WTD, BWTP Vol. 23, Structural Area 520 Membrane Basins, dated: 2013
- KC WTD. BWTP Vol. 16 Headworks Package
- KC WTD. BWTP Vol. 17 Grit Package
- KC WTD. BWTP Vol. 18 Headworks Truck Loadout Package
- KC WTD. BWTP Vol. 19 Primaries Package
- KC WTD. BWTP Vol. 20 PE Screens Package
- KC WTD. BWTP Vol. 21 HW Prim Odor Control Package
- KC WTD. BWTP Vol. 24 Aer MBR Odor Control Package
- KC WTD. BWTP Vol. 25 Disinfection Package
- KC WTD. BWTP Vol. 26 Chem Storage Package
- KC WTD. BWTP Vol. 27 Solids Bldg. Package
- Brightwater Anammox Cap Cost Assumptions
- KC WTD, Aeration Basin #4 RAS Anoxic Basin and Side Stream BOE, dated: 02.18.2018
- KC WTD, BW Membrane Cassettes 9 and 10 BOE, dated: 02.09.2018
- Brightwater Nitrogen Removal Alternatives – Cost Estimating Assumptions V2, undated.

### Equipment Quotes:

- Next Turbo Budget Quote, Aeration Blowers, dated: 10.25.2019
- Suez Budget Quote, MBR, dated: 10.21.2019
- Ovivo Budget Quote, Sidestream Anammox, dated: 12.18.2019
- Biostyr Budget Quote, Tertiary, dated: 12.19.2019
- Fairbanks Quotation Curve, IMLR Pumps, undated.
- Fairbanks Quotation Curve, Tertiary Feed Pumps, undated.

## 4.0 Planning Basis

---

The following planning basis assumptions were made for the project estimate:

- No project construction plan is in place at this time.
- The assumed execution strategy is a standard workweek with limited overtime.
- No unusual site conditions have been considered as part of this estimate.
- Adequate available power exists at the site.

## 5.0 Cost Basis

---

- All allied and indirect project costs (allowances for indeterminates, change order allowance, engineering, permitting, WTD staffing, etc.) have been estimated using WTD's PRISM cost model which is baselined to historical project costs.
- The estimate was performed based on drawings, sketches, and project information provided by King County and Brown and Caldwell Engineers.
- WTD is using a PRISM cost model dated January 26, 2017. All Allied and indirect project costs have been estimated using the new WTD PRISM cost model baselined to historical project costs.



## BASIS OF ESTIMATE

Project Name	<b>Brightwater Treatment Plant Nitrogen Removal - Alternative 3C</b>		
Project Number:		Date:	April 28, 2020

- Additional technical project complexity factors for WTD indirect project costs have been introduced and incorporated into project allied costs to allow for development of an additional WTD indirect cost allowance, based upon the unique characteristics of the project.
- Equipment factors were developed utilizing historical data which accounts for specific install of the identified equipment within a normal battery limit. Specific scope relative to this project was used in the equipment factor determination. Factors for each specific type of equipment reflect the different complexity of the installation. Engineering supplied equipment costs were multiplied by the factors in order to estimate direct construction cost for the purchase and install of the equipment.
- Estimated costs incorporate prevailing King County wage rates.
- All costs were estimated in 1<sup>st</sup> Quarter 2020 dollars.

### 6.0 Allowances

---

The level and types of allowances used in the estimate is as follows (common percentages for each alternative are shown and any estimate-specific differences are indicated):

- Sales Tax was included as 10.1% applied to the base construction cost, including the design and change order contingencies.
- A 25% Allowance for Indeterminates (AFI) is applied to the base construction cost. The AFI is an allowance that accounts for the cost of known but undefined requirements necessary for a complete and workable project. The AFI accounts for elements that are not explicitly shown in the project documents to be further defined as part of the design development and project delivery process. The AFI is carried at 25% at conceptual design, based on the WTD project delivery process.
- Allowance of 10% for potential construction change orders.
- Allowance of 0.2% of the primary construction amount for miscellaneous direct capital costs.
- Allowance of 0.88% of the primary construction amount for permitting and other agency support.
- Allowance of 1.8% of the primary construction amount for miscellaneous services and material.
- Allowance of 0.65% of the primary construction amount for Non-WTD Support.
- Allowance of 1.0% of the primary construction amount for art initiatives.
- Allowance of 0.5% of the total project cost for sustainability.
- Allowance for application of total project contingency (see *Contingency* section below).
- Allowance of 0% was included for Escalation as the estimate is produced in current year (2020) dollars.
- Allowance of 18.19% of the primary construction amount for Engineering Services.
- Allowance of 7.79% of the primary construction amount for Construction Management Support
- Allowance of 12.31% of the primary construction amount for WTD staff labor and burden.
- No Escalation has been included.

## BASIS OF ESTIMATE

Project Name	<b>Brightwater Treatment Plant Nitrogen Removal - Alternative 3C</b>		
Project Number:		Date:	April 28, 2020

- Additional estimating allowances for WTD indirect costs of approximately \$23.91 million have been included in the Total Project Cost estimate by using a moderate degree of complexity rating for Design Engineering, Construction Management, Permitting, Operations Support, and Project Management. Complexity factors were calibrated based on comments received from King County on March 04, 2020.
  - An allowance of \$18.24 million for Design and Construction Consulting
  - An allowance of \$0.88 million for Permitting & Other Agency Support
  - An allowance of \$4.78 million for WTD Staff Labor

### 7.0 Assumptions

---

Any other assumptions made by the estimator but not documented elsewhere in the estimate basis are included in this section.

- All costs included in the estimate reflect the best understanding of requirements as they existed at the time the estimates were prepared. Any modifications to the present scope and/or location of the project site may have substantial cost and schedule impacts.
- The engineering design will be performed by an external consultant engineer.
- Construction management will not be performed “in-house” by WTD. It will be performed by an external consultant construction manager.
- The project will generally align with the WTD PRISM cost model for Treatment projects.
- All work will always be performed utilizing safe work methods.
- Work will be sequenced to minimize standard process, service, and community interruptions. However, no costs are included to address sequencing necessary to keep the plant operational during construction.
- No costs are included for any new facilities that would be required, beyond the scope of this project to replace any lost capacity to the Brightwater Treatment Plant.
- It is assumed that the best improvement solution is included in the project scope(s).
- There will be some degree of productivity loss due to the site location. Some degree of productivity loss is included in the estimated costs. Any unusual site conditions are not accounted for in this estimate.
- Any additional work discovered during project implementation would need to be either a supplemental approval of added scope or be approved as an additional project.
- This project will be engineered to meet Washington State area seismic requirements.
- A degree of minimal cost rounding will occur during the normal estimating process.
- No allowance is included for Material Pricing Uncertainty.
- Power is readily available in the general area of this project. No new power sources are included in the scope of this project.

## **BASIS OF ESTIMATE**

Project Name	<b>Brightwater Treatment Plant Nitrogen Removal - Alternative 3C</b>		
Project Number:		Date:	April 28, 2020

- It is assumed that some general material contamination is present. The estimate covers minimal cost of removal wherever the contamination is disturbed during construction. This cost is covered in productivity rates utilized in the estimate.

### **8.0 Exclusions**

---

All potential items of cost which might be associated with the project but for which no costs have been included are listed below:

- No asbestos removal costs are included.
- No estimated costs are included for any potential delays due to interferences.
- No costs are included for utility relocations.
- No costs are included for temporary construction easements.
- No costs are included for street use or street improvement permits.
- No costs are included for additional scope beyond that as detailed in the current scope of work.

### **9.0 Exceptions**

---

This estimate is classified as a King County Wastewater Treatment Division Class 5 estimate based on an AACE International Class 5 estimate, with no exceptions per the King County WTD project process, for the scope as known at the time of the estimate preparation.

### **10.0 Risks (Threats and Opportunities)**

---

At the time of estimate preparation, a formal risk analysis session had not been conducted. General potential risks are listed below.

- There is a risk that additional scope, technology advances or major deviation from the suggested project scope will adversely impact cost and schedule.
- Future unknown or changing site conditions present a risk around productivities, schedule, and costs.
- More stringent or completely new regulations, usage fees, permitting, or environmental impacts may result in risks that could adversely impact cost and schedule.
- Potential complex construction and constructability issues could arise during construction, resulting in major design/construction changes.
- The space constraints could significantly impact assumed productivities and crew sizes identified for the estimated concept, resulting in increased costs due to loss of production.
- The scheduled timing of project execution will greatly impact the bottom-line costs. There is risk related to labor availability and fluctuating commodity and equipment pricing in the timeframe between this early conceptual estimate and the actual execution of the project. Rising costs due to inflation, escalation and competing major worldwide projects pose the possibility of noticeable project cost and schedule increases.
- Weather conditions and emergency service interruptions present the possibility of negative schedule and cost impacts.

## BASIS OF ESTIMATE

Project Name	<b>Brightwater Treatment Plant Nitrogen Removal - Alternative 3C</b>		
Project Number:		Date:	April 28, 2020

- Any possible coordination with other agencies could result in potential impacts on costs, schedule and Project Definition process.
- There is a risk that stakeholders could oppose the proposed design or prefer a different approach or site to be selected, resulting in schedule delays and a higher cost alternative.

### 11.0 Contingency

---

Contingency is a cost element of the estimate used to cover uncertainties and unforeseeable elements of cost within the defined project scope. Contingency covers inadequacies in project scope definition, estimating methods, and estimating data. Contingency specifically excludes changes in project scope, and unforeseen major events such as earthquakes, prolonged labor strikes, etc.

A 30% Project Contingency was added to the base estimate of Total Project Costs (direct and indirect) as a result of the project estimating process and in accordance with the King County WTD project delivery process.

The estimating analysis resulted in a project contingency of approximately \$110.3 million (US\$).

The total project cost at a 50% confidence level (P50) is typically used for funding and baselining of a project at this stage and level of engineering and project development. The P50 confidence level suggests that there is a 50% cumulative probability of project cost under-run (or 50% probability of exceedance) at this dollar amount for the presently defined and known project scope.

### 12.0 Management Reserve

---

No allocation of costs was included in this estimate for Management Reserves.

Contingency is not intended to cover the costs for changes in project scope. If the project needs to provide an allowance for anticipated changes in scope or to cover the costs for items that may be required but have not yet been specifically identified as being included in the current project scope, then that amount of cost should be identified here.

### 13.0 Reconciliation

---

Reconciliation was not conducted at this time.

### 14.0 Benchmarking

---

All included Allied Costs as supplied by the PRISM historical database have been benchmarked against a similar portfolio of recently completed projects.

### 15.0 Estimate Quality Assurance Plan

---

No reviews of total project costs have been conducted outside the reviews conducted within Brown and Caldwell and VMS estimating team. It is anticipated that upon completion of this estimate, reviews will happen between the estimate provider and WTD.

## BASIS OF ESTIMATE

Project Name	<b>Brightwater Treatment Plant Nitrogen Removal - Alternative 3C</b>		
Project Number:		Date:	April 28, 2020

### 16.0 Attachments

#### Attachment: Estimate Deliverables

Engineering and Estimating Deliverables provided include:

- Brown and Caldwell Layout, Brightwater Nitrogen Removal Study, 7ea. Alternative Marked Up Sketches, (Alt.1/2A/2B/2C/3A/3B/3C), undated
- Brown and Caldwell, Tertiary Feed Pump Station Wetwell layout, Alt. 2C/3C, undated.
- Brown and Caldwell, BW Nitrogen Removal Alt. Cost Estimating Alt1/2A/2B/2C/3A/3B/3C, v0, undated
- KC, WPTP, Aeration Basin Plan View, dated: 01.18.2010
- KC, WPTP, Aeration Basin 2ea Sketch SND Alt.1, dated: 09.05.2013
- KC, WPTP, Aeration Basin 2ea Sketch SND Alt. 2A/3A, dated: 09.05.2013
- KC, WPTP, Aeration Basin 2ea Sketch MLE Alt. 2B/2C/3C, dated: 09.05.2013
- KC, WPTP, Aeration Basin 2ea Sketch 4SMB Alt. 3B, dated: 09.05.2013
- Estimation of MBR as final construction cost of Brightwater, dated: 12.11.2019
- Membrane Tanks 9 and 10 Estimate, Eric Benton, dated: 01.05.2018
- New Aeration Basin, East blower Room and Anoxic Basin Estimate, Eric Benton, dated: 02.06.2018
- Veolia, Biostyr Example Drawings 5ea, dated: 02.27.2019
- BW – YP – SD Model All Yard Piping, undated PDF
- KC WTD, BWTP Vol. 11, General Sheets and Legends, Record Drawings, dated: Nov. 2012
- KC WTD, BWTP Vol. 12, Process and Instrumentation Diagrams, dated: 2013
- KC WTD, BWTP Vol. 22, Mechanical Area 510 Aeration Basins, dated: 2013
- KC WTD, BWTP Vol. 22, Structural Area 510 Aeration Basins, dated: 2013
- KC WTD, BWTP Vol. 23, Mechanical Area 520 Membrane Basins, dated: 2013
- KC WTD, BWTP Vol. 23, Structural Area 520 Membrane Basins, dated: 2013
- KC WTD. BWTP Vol. 16 Headworks Package
- KC WTD. BWTP Vol. 17 Grit Package
- KC WTD. BWTP Vol. 18 Headworks Truck Loadout Package
- KC WTD. BWTP Vol. 19 Primaries Package
- KC WTD. BWTP Vol. 20 PE Screens Package
- KC WTD. BWTP Vol. 21 HW Prim Odor Control Package
- KC WTD. BWTP Vol. 24 Aer MBR Odor Control Package
- KC WTD. BWTP Vol. 25 Disinfection Package
- KC WTD. BWTP Vol. 26 Chem Storage Package
- KC WTD. BWTP Vol. 27 Solids Bldg. Package
- Brightwater Anammox Cap Cost Assumptions
- KC WTD, Aeration Basin #4 RAS Anoxic Basin and Side Stream BOE, dated: 02.18.2018
- KC WTD, BW Membrane Cassettes 9 and 10 BOE, dated: 02.09.2018
- Brightwater Nitrogen Removal Alternatives – Cost Estimating Assumptions V2, undated.

Equipment Quotes:

- Next Turbo Budget Quote, Aeration Blowers, dated: 10.25.2019
- Suez Budget Quote, MBR, dated: 10.21.2019
- Ovivo Budget Quote, Sidestream Anammox, dated: 12.18.2019

## BASIS OF ESTIMATE

Project Name	<b>Brightwater Treatment Plant Nitrogen Removal - Alternative 3C</b>		
Project Number:		Date:	April 28, 2020

- Biostyr Budget Quote, Tertiary, dated: 12.19.2019
- Fairbanks Quotation Curve, IMLR Pumps, undated.
- Fairbanks Quotation Curve, Tertiary Feed Pumps, undated.

## **Attachment D: Budgetary Proposals for Equipment**

---





**From:** Allen, Chris <chris.allen@suez.com>  
**Sent:** Wednesday, January 08, 2020 2:53 PM  
**To:** Matt Winkler  
**Cc:** jkernkamp@apsco-llc.com  
**Subject:** RE: Brightwater MBR Budgetary Proposal

Hi Matt. I've looked into this at a high level. Going with 8 new trains (2 existing trains + 6 new trains) with 20 cassettes per train. Each cassette holding 52 modules. Each module with 370sf of membrane surface area. Assumes 10% spare space. This design lines up with a 10 gfd limiting flux.

- 8 trains
- 160 cassettes (20 per train)
- 7488 modules (assumes 10% spare space)
- 2,770,560sf of membrane surface area
- Estimated price \$15MM +/- 3.5%

Hope this information will suffice for now.

Regards,  
Chris

**Chris Allen, P.E.**  
Western Regional Manager  
**Water Technologies & Solutions**

Tel: +1 503-307-2238



[www.suezwatertechnologies.com](http://www.suezwatertechnologies.com)

**\$15,000,000 cost included \$4,200,000 for membrane basins 9 and 10. Cost for equipment for 6 new membrane basins would therefore be \$15,000,000 minus \$4,200,000, or approximately \$10,800,000. This budgetary pricing was used in the cost estimating for new membrane basins.**

# 16" 8411 Quotation Curve



FAIRBANKS NIJHUIS™

<b>CURVE NUMBER:</b>	C-W190258C	<b>SPEED</b>	<b>DRIVER</b>	<b>DIAMETER</b>	<b>SPHERE</b>	<b>GUARANTEED VALUES</b>			
<b>REV.</b>	0	880 RPM	25 HP	STD	1.20"	<b>FLOW</b>	<b>HEAD</b>	<b>PUMP EFF</b>	<b>HP</b>
THIS CURVE IS BASED ON THE ACTUAL TEST PERFORMANCE OF A SIMILAR PUMP. ONLY THE INDICATED POINT(S) IS GUARANTEED.		<b>STAGES</b>	<b>IMPELLER</b>	<b>DATE</b>	<b>BY</b>	9.5	10	71	----
		1	STD	1/3/2020	WSF	----	----	----	----
		Performance testing will utilize Acceptance Grade 1E per ANSI/HI 14.6.3.4.				----	----	----	----

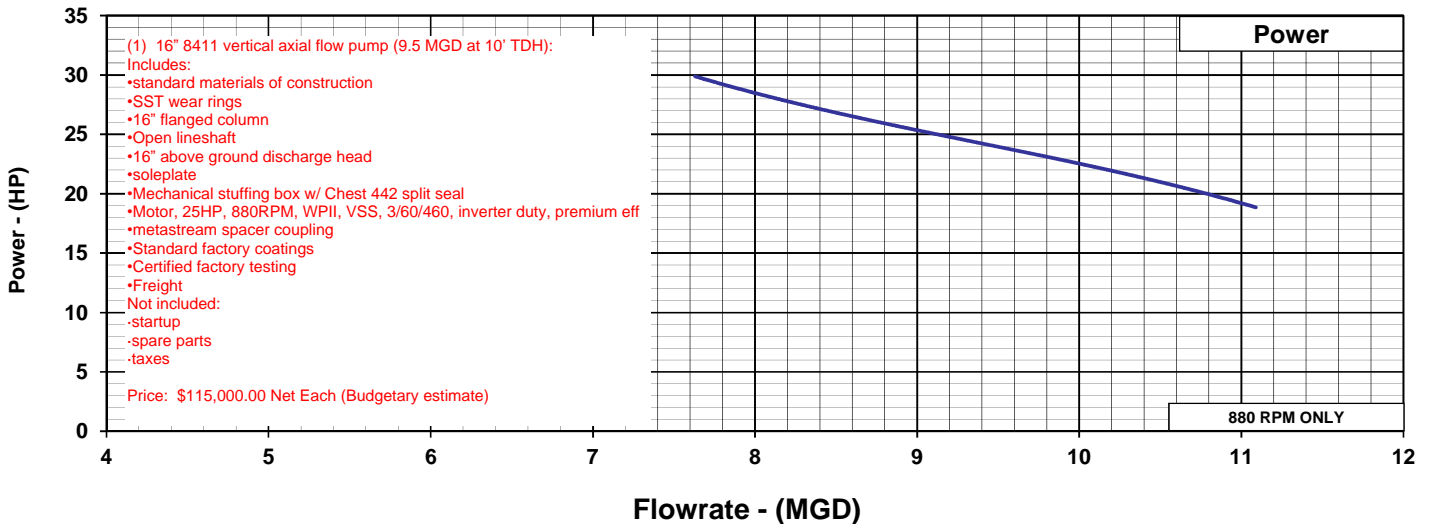
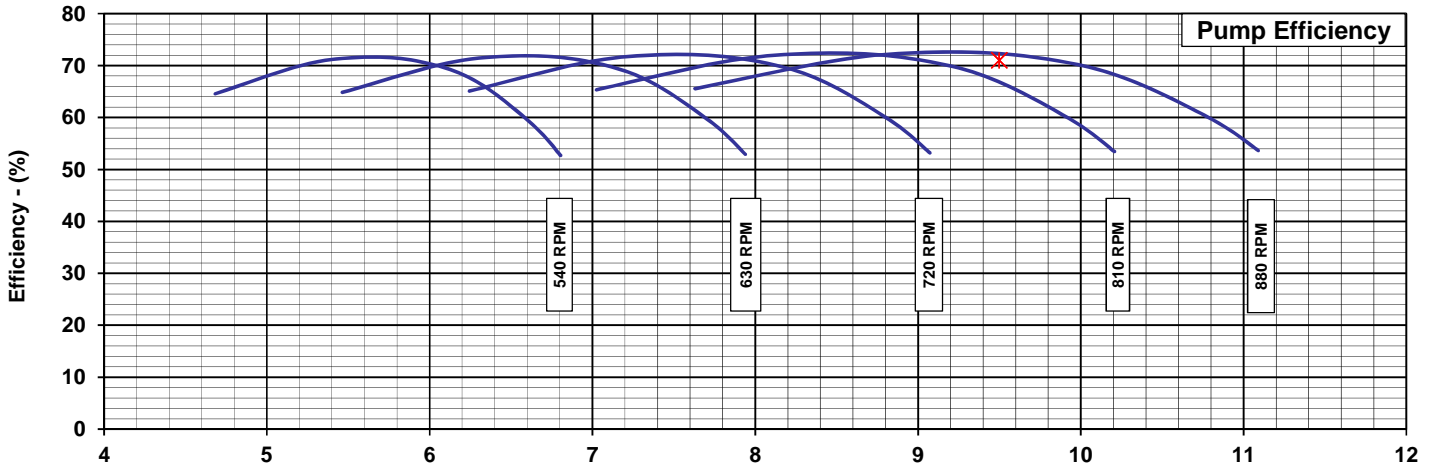
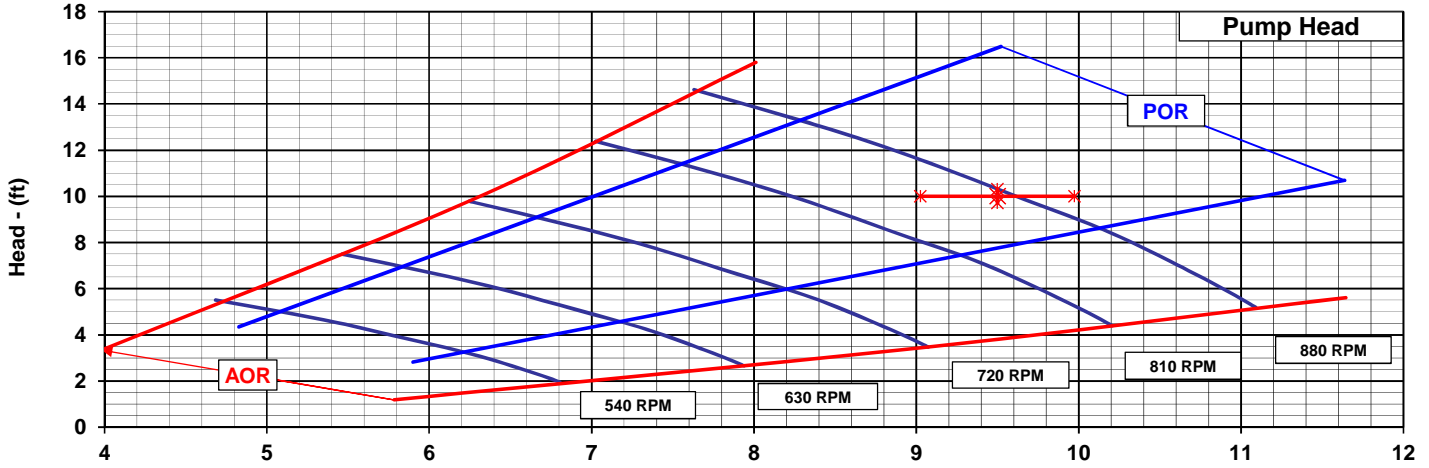

# 20" 8411 Quotation Curve



FAIRBANKS NIJHUIS™

<b>CURVE NUMBER:</b>	C-W190258D	<b>SPEED</b>	700 RPM	<b>DRIVER</b>	50 HP	<b>DIAMETER</b>	STD	<b>SPHERE</b>	1.70"	<b>GUARANTEED VALUES</b>							
<b>REV.</b>	0	<b>STAGES</b>	1	<b>IMPELLER</b>	STD	<b>DATE</b>	1/6/2020	<b>BY</b>	WSF	<b>FLOW</b>	16.5	<b>HEAD</b>	10	<b>PUMP EFF</b>	69	<b>HP</b>	----
THIS CURVE IS BASED ON THE ACTUAL TEST PERFORMANCE OF A SIMILAR PUMP. ONLY THE INDICATED POINT(S) IS GUARANTEED.		Performance testing will utilize Acceptance Grade 1U per ANSI/HI 14.6.3.4.				<b>FLOW</b>	----	<b>HEAD</b>	----	<b>PUMP EFF</b>	----	<b>HP</b>	----				
		<b>FLOW</b>	----	<b>HEAD</b>	----	<b>PUMP EFF</b>	----	<b>HP</b>	----								
		<b>FLOW</b>	----	<b>HEAD</b>	----	<b>PUMP EFF</b>	----	<b>HP</b>	----								
		<b>FLOW</b>	----	<b>HEAD</b>	----	<b>PUMP EFF</b>	----	<b>HP</b>	----								

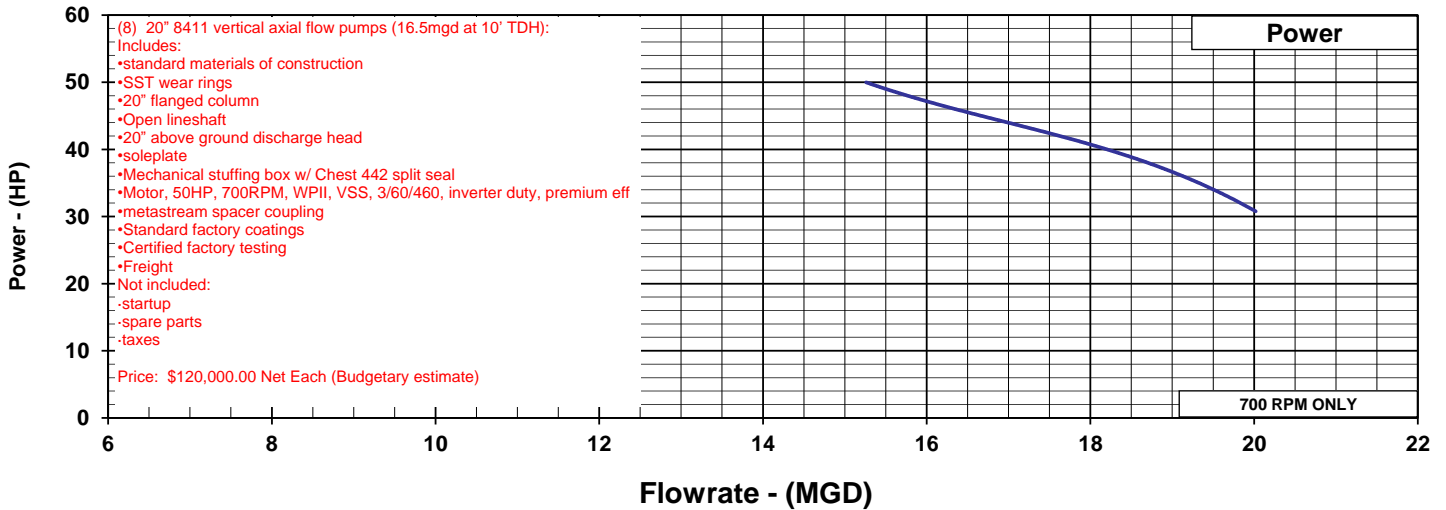
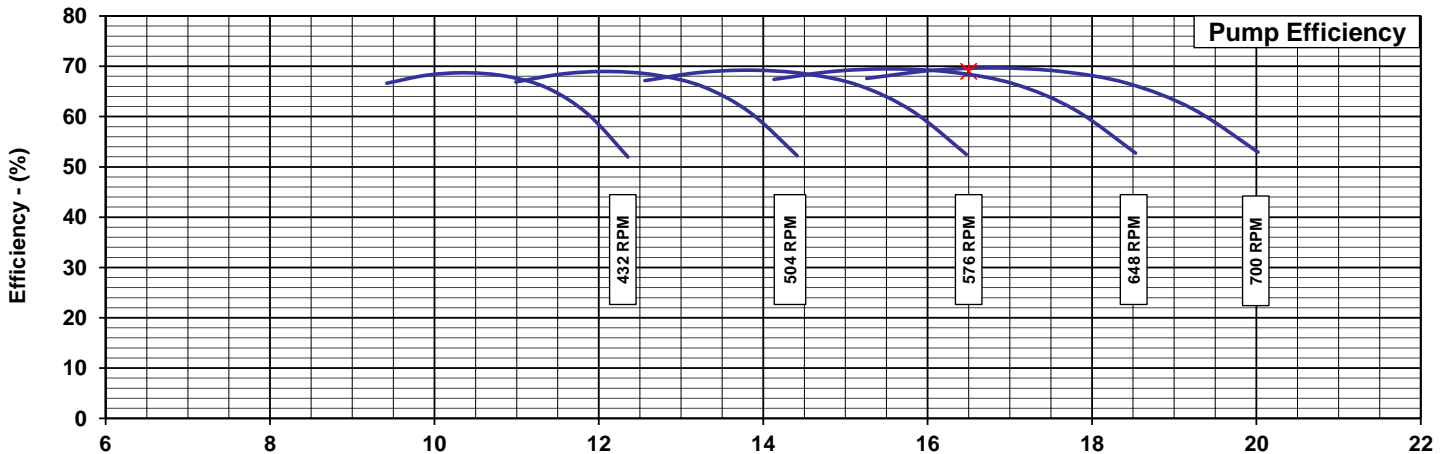
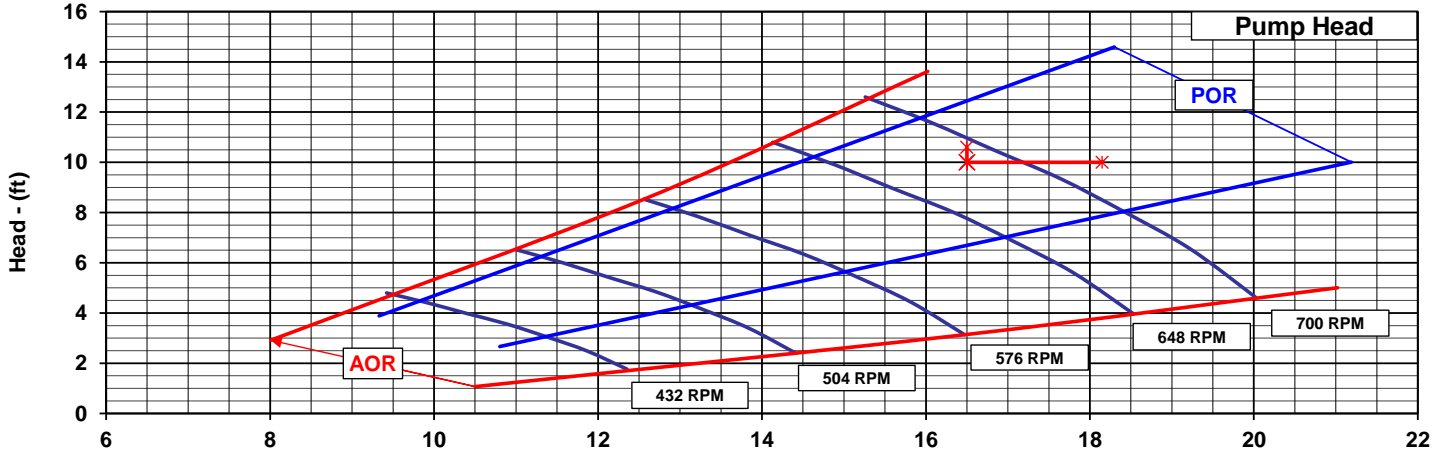

- (8) 20" 8411 vertical axial flow pumps (16.5mgd at 10' TDH):
- Includes:
- standard materials of construction
- SST wear rings
- 20" flanged column
- Open lineshaft
- 20" above ground discharge head
- soleplate
- Mechanical stuffing box w/ Chest 442 split seal
- Motor, 50HP, 700RPM, WP11, VSS, 3/60/460, inverter duty, premium eff
- metastream spacer coupling
- Standard factory coatings
- Certified factory testing
- Freight
- Not included:
- startup
- spare parts
- taxes
- Price: \$120,000.00 Net Each (Budgetary estimate)

# 24" 8411 Quotation Curve



FAIRBANKS NIJHUIS™

<b>CURVE NUMBER:</b>	C-W190258E	<b>SPEED</b>	590 RPM	<b>DRIVER</b>	60 HP	<b>DIAMETER</b>	STD	<b>SPHERE</b>	1.90"	<b>GUARANTEED VALUES</b>							
<b>REV.</b>	0	<b>STAGES</b>	1	<b>IMPELLER</b>	STD	<b>DATE</b>	1/6/2020	<b>BY</b>	WSF	<b>FLOW</b>	20.0	<b>HEAD</b>	10	<b>PUMP EFF</b>	71.5	<b>HP</b>	----
THIS CURVE IS BASED ON THE ACTUAL TEST PERFORMANCE OF A SIMILAR PUMP. ONLY THE INDICATED POINT(S) IS GUARANTEED.		Performance testing will utilize Acceptance Grade 1U per ANSI/HI 14.6.3.4.				<b>FLOW</b>	----	<b>HEAD</b>	----	<b>PUMP EFF</b>	----	<b>HP</b>	----				
		<b>FLOW</b>	----	<b>HEAD</b>	----	<b>PUMP EFF</b>	----	<b>HP</b>	----								
		<b>FLOW</b>	----	<b>HEAD</b>	----	<b>PUMP EFF</b>	----	<b>HP</b>	----								
		<b>FLOW</b>	----	<b>HEAD</b>	----	<b>PUMP EFF</b>	----	<b>HP</b>	----								

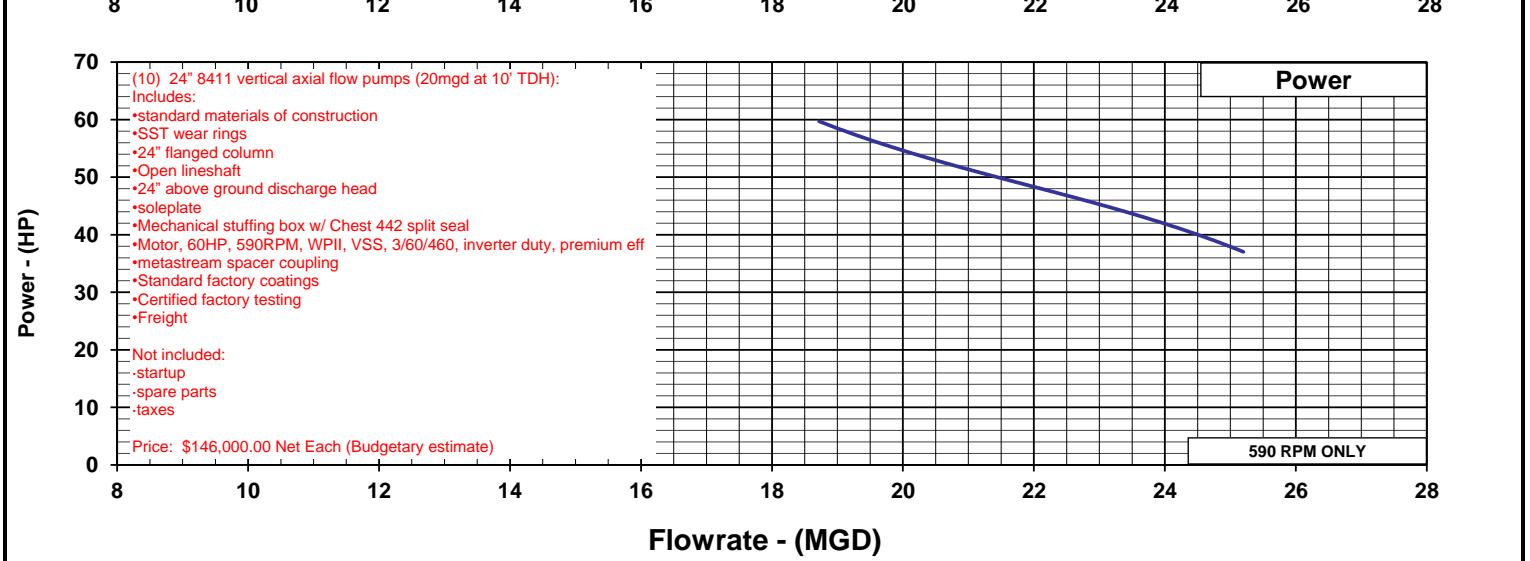
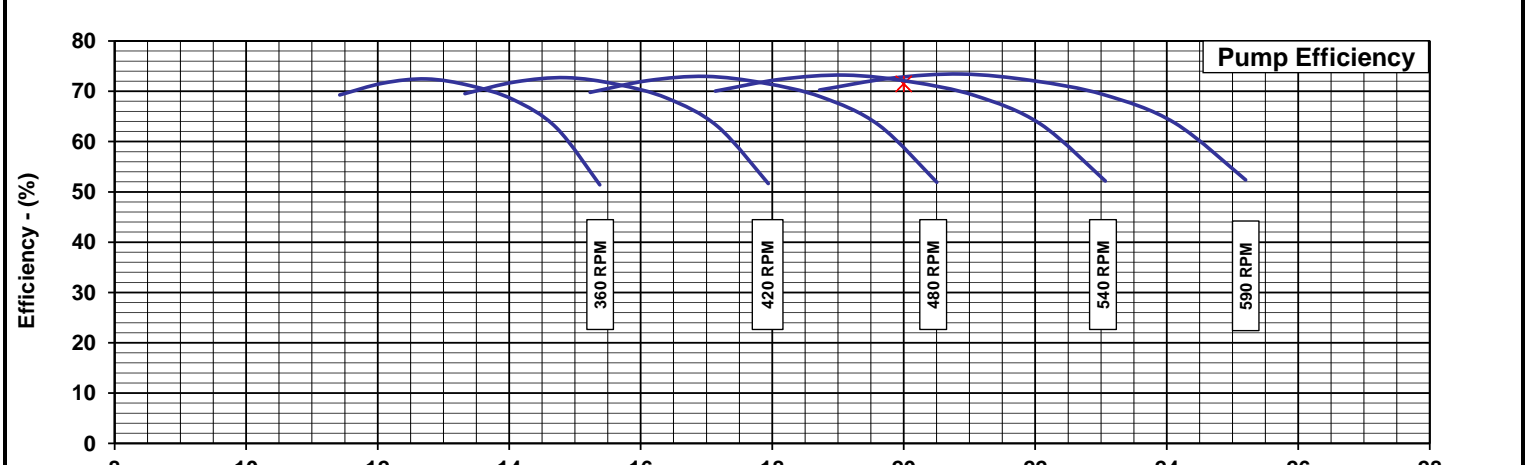
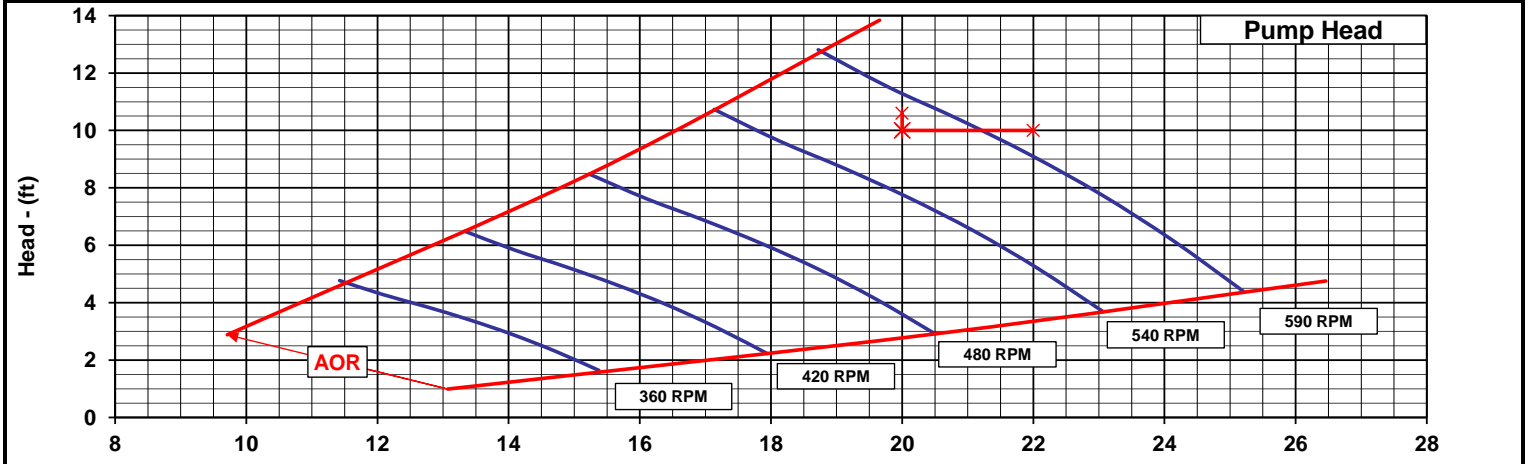

**KING COUNTY BRIGHTWATER WWTP  
SEATTLE, WA**

**AnammoPAQ® System**

**PREPARED FOR**

**Brown and Caldwell**

Matt Winkler

[mwinkler@brwnald.com](mailto:mwinkler@brwnald.com)

**AREA REPRESENTATIVE**

**Goble Sampson**

Douglas Allie

[dallie@goblesampson.com](mailto:dallie@goblesampson.com)

**PREPARED BY**

Mudit Gangal

Phone: (512)-834-6042

[mudit.gangal@ovivowater.com](mailto:mudit.gangal@ovivowater.com)

**Ovivo USA, LLC**

2300 Greenhill Dr. Bldg. #100

Round Rock, Texas, 78664, USA

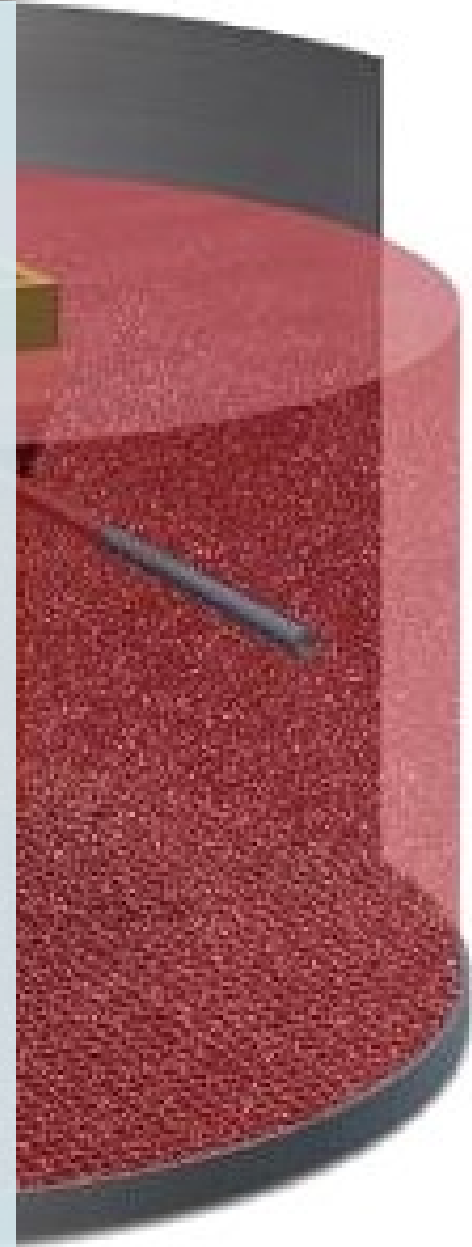

December 18, 2019

Attn: Mr. Matt Winkler  
Brown and Caldwell

Re: King County Brightwater WWTP, WA  
Ovivo AnammoPAQ® System  
Proposal No. 121819-1-MG-R0

Dear Mr. Winkler,

With regard to your recent request for the King County Brightwater WWTP, WA, Ovivo USA, LLC is pleased to submit this preliminary proposal for its AnammoPAQ® system. The system design is based on the influent high nitrogen stream at the King County Brightwater WWTP, WA having a design (Max Month) flow of 0.186 MGD to achieve approximately 80% Ammonia-N removal.

It is assumed that the dewatering will occur 24 hours a day and 7 days a week with AnammoPAQ® system operation 7 days a week. It is also assumed enough equalization and pre-treatment to reduce TSS and PO<sub>4</sub>-P content (while maintaining influent alkalinity) will be provided (by others) and all equipment in the equalization tank including feed pumps will be by others.

We have endeavored to provide complete information in this proposal. However, if you have any questions or need additional information, please feel free to contact Doug, our regional sales representative, or me directly.

Sincerely,

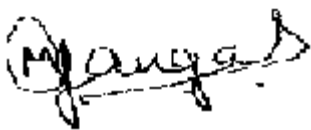

**Mudit Gangal**  
Product Group Manager  
Biosolids Management and Resource Recovery  
Ovivo USA, LLC



2300 Green Hill, Round Rock, Texas 78664  
P: 512-834-6042 C: 512-590-0391 F: 512-834-6039

---

© Copyright 2019 OVIVO. All rights reserved.

This document is confidential and shall remain the sole property of Ovivo. This document may not be reproduced or distributed without prior written approval of Ovivo. The data and information provided is furnished on a restricted basis and is not to be used in any way detrimental to the interests of Ovivo  
THIS BUDGETARY PROPOSAL CONSTITUTES A NON-BINDING ESTIMATE OF PRICE(S) FOR CERTAIN GOODS AND/OR SERVICES THAT MAY BE PROVIDED BY OVIVO USA LLC FROM TIME TO TIME, BUT SHALL NOT BE CONSTRUED AS A CONTRACTUAL OFFER FOR OVIVO USA LLC TO PROVIDE SUCH GOODS AND/OR SERVICES. ANY CONTRACTUAL OFFER FOR THE SUPPLY OF GOODS AND/OR SERVICES BY OVIVO USA LLC SHALL BE CONVEYED TO CUSTOMER IN THE FORM OF OVIVO USA LLC'S STANDARD PROPOSAL DOCUMENT, WHICH INCLUDES, BUT IS NOT LIMITED TO, ITS STANDARD TERMS AND CONDITIONS OF SALE. SUCH PROPOSAL FORM MAY BE PROVIDED TO CUSTOMER UPON REQUEST.

## INTRODUCTION

The King County Brightwater WWTP, WA is in the process of evaluating technologies for treatment of its high Nitrogen content side-stream to reduce the Ammonia-N load to help meet its effluent permits in an efficient manner. The design flows and loads required to be treated by using the AnammoPAQ® treatment process to reduce the Ammonia-N concentration in the effluent stream being discharged to more acceptable limits are provided in Table 1 below.

## BASIS OF DESIGN

The AnammoPAQ® system design and performance are based on the design information provided by Brown and Caldwell. Table 1 summarizes the parameters used for developing the proposed solution.

Treatment Parameter	Units	Influent	Treated Effluent
Equalized Design Flow	MGD	0.186	
Design Temperature	°C	30	
BOD	mg/l	92	
TSS	mg/l	< 300	
NH <sub>3</sub> -N	mg/l	1,146	< 170
TKN	mg/l	1,273	
Alkalinity	mg/l	4,000	
PO <sub>4</sub> -P	mg/l	< 50	

The design is based on the following assumption(s):

- The influent flows are produced seven (7) days a week, twenty-four (24) hours a day.

The King County Brightwater WWTP, WA AnammoPAQ® system was designed using extensive modeling and experience from Ovivo's pilot and full-scale installations. The modeling assists in process selection and determining the optimal volumes for treatment and the overall process operating parameters.



## OVIVO-PAQUES ANAMMOPAQ® EXPERIENCE

The Ovivo-Paques AnammoPAQ® system currently has over 62 operating nitrogen removal deammonification systems worldwide. Further, Ovivo's AnammoPAQ® installation base cumulatively treats globally Nitrogen loads in excess of 300,000 lbs N/d, which is second to none. This is estimated to be around 80% of all Ammonia-N load currently treated in engineered systems utilizing anammox bacteria worldwide.



**Figure:1 Modular AnammoPAQ® setup at Rendac, The Netherland (13,000 lds N/day)**

**© Copyright 2019 OVIVO. All rights reserved.**

This document is confidential and shall remain the sole property of Ovivo. This document may not be reproduced or distributed without prior written approval of Ovivo. The data and information provided is furnished on a restricted basis and is not to be used in any way detrimental to the interests of Ovivo  
THIS BUDGETARY PROPOSAL CONSTITUTES A NON-BINDING ESTIMATE OF PRICE(S) FOR CERTAIN GOODS AND/OR SERVICES THAT MAY BE PROVIDED BY OVIVO USA LLC FROM TIME TO TIME, BUT SHALL NOT BE CONSTRUED AS A CONTRACTUAL OFFER FOR OVIVO USA LLC TO PROVIDE SUCH GOODS AND/OR SERVICES. ANY CONTRACTUAL OFFER FOR THE SUPPLY OF GOODS AND/OR SERVICES BY OVIVO USA LLC SHALL BE CONVEYED TO CUSTOMER IN THE FORM OF OVIVO USA LLC'S STANDARD PROPOSAL DOCUMENT, WHICH INCLUDES, BUT IS NOT LIMITED TO, ITS STANDARD TERMS AND CONDITIONS OF SALE. SUCH PROPOSAL FORM MAY BE PROVIDED TO CUSTOMER UPON REQUEST.

## TREATMENT APPROACH

In the AnammoPAQ<sup>®</sup> reactor, ammonium is converted to nitrogen gas. The reaction is executed by two different bacteria, which coexist in the reactor. Ammonium oxidizing bacteria (AOB) oxidize about half of the ammonium to nitrite. Anammox bacteria then convert the remaining ammonium and nitrite, into nitrogen gas. The overall reaction of the one step AnammoPAQ<sup>®</sup> reactor is:

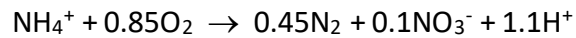

The deammonification conversion thus is an elegant shortcut in the natural nitrogen cycle. A key feature of the AnammoPAQ<sup>®</sup> system is that ammonium is removed from the reject water stream in one treatment step without the use of external carbon sources and with minimal energy input.

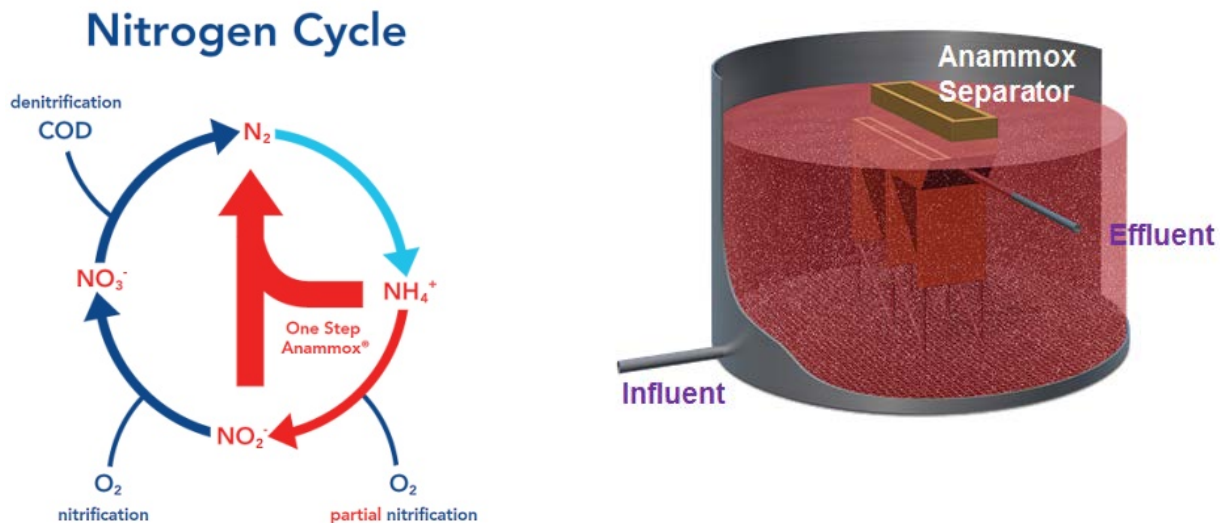

The AnammoPAQ<sup>®</sup> reactor is a continuously fed and aerated tank, equipped with Ovivo's patented biomass retention system. The aeration provides for rapid mixing of the influent with the reactor content, intense contact with the biomass and oxygen supply to drive the conversion. This process is based on granular biomass. The aeration is controlled in order to selectively convert ammonium to nitrogen gas. Around 10% of the ammonium is converted into nitrate. The treated wastewater leaves the reactor via the biomass retention system at the top of the reactor.

© Copyright 2019 OVIVO. All rights reserved.

This document is confidential and shall remain the sole property of Ovivo. This document may not be reproduced or distributed without prior written approval of Ovivo. The data and information provided is furnished on a restricted basis and is not to be used in any way detrimental to the interests of Ovivo.

THIS BUDGETARY PROPOSAL CONSTITUTES A NON-BINDING ESTIMATE OF PRICE(S) FOR CERTAIN GOODS AND/OR SERVICES THAT MAY BE PROVIDED BY OVIVO USA LLC FROM TIME TO TIME, BUT SHALL NOT BE CONSTRUED AS A CONTRACTUAL OFFER FOR OVIVO USA LLC TO PROVIDE SUCH GOODS AND/OR SERVICES. ANY CONTRACTUAL OFFER FOR THE SUPPLY OF GOODS AND/OR SERVICES BY OVIVO USA LLC SHALL BE CONVEYED TO CUSTOMER IN THE FORM OF OVIVO USA LLC'S STANDARD PROPOSAL DOCUMENT, WHICH INCLUDES, BUT IS NOT LIMITED TO, ITS STANDARD TERMS AND CONDITIONS OF SALE. SUCH PROPOSAL FORM MAY BE PROVIDED TO CUSTOMER UPON REQUEST.

The granular biomass is separated from the cleaned wastewater, assuring high biomass content in the reactor. Together with the dense conversion properties typical for granular biomass, the high biomass content provides for high loading/conversion rates and therefore a small reactor volume.

### AnammoPAQ® PROCESS ADVANTAGES

Main benefits of implementing the AnammoPAQ® system for Nitrogen removal are the significant savings on operational costs and environmental impact compared to conventional and alternative deammonification systems. These include:

- Aeration Energy Savings (over 60%)
- Elimination of external Carbon source (100% saving)
- Reduction in sludge production (up to 90%)
- Compact footprint
- High Loading Rates
- Reduction in CO2 emission
- Limited chemical consumption
- Fast start up due to inoculation with granular biomass
- Robust process: Tolerant to presence of toxic chemicals
- Ability to handle high suspended solids in influent

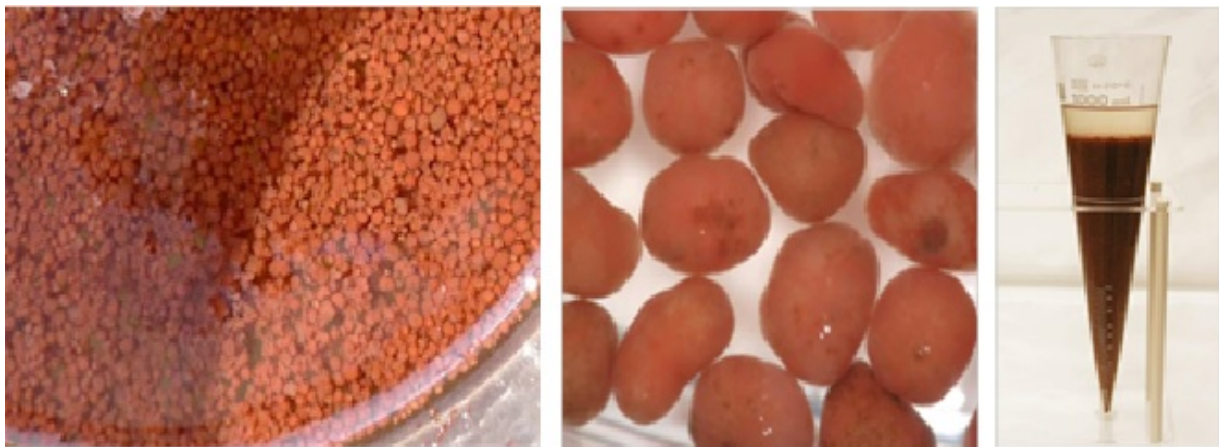

**Anammox Granular Biomass**

## AnammoPAQ® PROCESS DESIGN

The system for the King County Brightwater WWTP, WA has been designed using proprietary models to perform process selection and to determine essential operating parameters.

A summary of the AnammoPAQ® system design is provided in Table 2. This table demonstrates the volumes required to achieve desired effluent Ammonia-N reduction, and provides associated process design details.

Treatment Parameter	Unit	Value
Equalized Design Flow	MGD	0.186
Total No. of AnammoPAQ® Reactors	#	2
Volume of AnammoPAQ® Reactors (each)	Gallons	94,000
AnammoPAQ® Reactor Length	ft	25
AnammoPAQ® Reactor Width	ft	25
AnammoPAQ® Reactor SWD	ft	20
Air Flow for AnammoPAQ® Reactor	scfm	815

**© Copyright 2019 OVIVO. All rights reserved.**

This document is confidential and shall remain the sole property of Ovivo. This document may not be reproduced or distributed without prior written approval of Ovivo. The data and information provided is furnished on a restricted basis and is not to be used in any way detrimental to the interests of Ovivo.

THIS BUDGETARY PROPOSAL CONSTITUTES A NON-BINDING ESTIMATE OF PRICE(S) FOR CERTAIN GOODS AND/OR SERVICES THAT MAY BE PROVIDED BY OVIVO USA LLC FROM TIME TO TIME, BUT SHALL NOT BE CONSTRUED AS A CONTRACTUAL OFFER FOR OVIVO USA LLC TO PROVIDE SUCH GOODS AND/OR SERVICES. ANY CONTRACTUAL OFFER FOR THE SUPPLY OF GOODS AND/OR SERVICES BY OVIVO USA LLC SHALL BE CONVEYED TO CUSTOMER IN THE FORM OF OVIVO USA LLC'S STANDARD PROPOSAL DOCUMENT, WHICH INCLUDES, BUT IS NOT LIMITED TO, ITS STANDARD TERMS AND CONDITIONS OF SALE. SUCH PROPOSAL FORM MAY BE PROVIDED TO CUSTOMER UPON REQUEST.

## SCOPE

### SCOPE OF SUPPLY

The following table outlines the Ovivo AnammoPAQ® system scope of supply for the proposed project.

Scope of Supply		
Item	Qty	Description
1	2	AnammoPAQ® reactor <u>internals</u> (suitable for each 94,000 Gal tank – tank by others) <ul style="list-style-type: none"> <li>• 1 x Type 10 Separator and support construction</li> <li>• Fine Bubble aeration system with Aerostrip® diffusers, basin piping for c/w drop legs, flanged diffuser pipes, mounting brackets and connection fasteners. Capacity: 815 scfm</li> <li>• Piping for aeration, influent, effluent, biomass sampling</li> </ul>
2	3 (2+1)	Process Air Blowers for AnammoPAQ® with VFD; Capacity: 815 scfm each
3	Lot	Anammox granular biomass
4	Lot	Controls and Instrumentation (NH <sub>4</sub> <sup>+</sup> , NO <sub>3</sub> <sup>-</sup> , NO <sub>2</sub> <sup>-</sup> , DO, pH, T)
5	2	Sets of O&M Manuals
6	2	Sets of Detailed Shop Drawings
7	20	Service Days, to inspect equipment installation, test all supplied components, assist in start-up and train plant personnel.

© Copyright 2019 OVIVO. All rights reserved.

This document is confidential and shall remain the sole property of Ovivo. This document may not be reproduced or distributed without prior written approval of Ovivo. The data and information provided is furnished on a restricted basis and is not to be used in any way detrimental to the interests of Ovivo.

THIS BUDGETARY PROPOSAL CONSTITUTES A NON-BINDING ESTIMATE OF PRICE(S) FOR CERTAIN GOODS AND/OR SERVICES THAT MAY BE PROVIDED BY OVIVO USA LLC FROM TIME TO TIME, BUT SHALL NOT BE CONSTRUED AS A CONTRACTUAL OFFER FOR OVIVO USA LLC TO PROVIDE SUCH GOODS AND/OR SERVICES. ANY CONTRACTUAL OFFER FOR THE SUPPLY OF GOODS AND/OR SERVICES BY OVIVO USA LLC SHALL BE CONVEYED TO CUSTOMER IN THE FORM OF OVIVO USA LLC'S STANDARD PROPOSAL DOCUMENT, WHICH INCLUDES, BUT IS NOT LIMITED TO, ITS STANDARD TERMS AND CONDITIONS OF SALE. SUCH PROPOSAL FORM MAY BE PROVIDED TO CUSTOMER UPON REQUEST.

## ITEMS BY OTHERS

The following items are specifically not by Ovivo. They may or may not be required.

Items Not Included	
Air Main Piping and all accessories including valves, bolts gaskets and connectors for attaching to drop pipes	Yard Hydrants
Chemical Feed Systems for alkalinity correction, magnesium oxide, nutrients, methanol and defoamer	Mixers
Chemicals for operation: Including methanol, nutrients, alkaline solution, defoamer	Motor Control Center (MCC)
Cleanouts	Non-potable water supply
Concrete	Overflow structures including baffles and weir plates
Drains	Power
Dryers	Dilution Water
Engines/Generators	Pre-treatment systems for deammonification system (e.g. influent TSS removal system, Phosphorus removal system and COD removal system)
Equalization Tank and equipment therein	Sludge handling and disposal
Foam control	Support Platforms
Hoses /Bibs	Tanks (and modifications to tankage – existing or new)
Influent/Feed Pumps	Transformers
Interconnecting Piping	Valves – Manual and Automatic
Laboratory	Variable Frequency Drives for blowers and pumps
Ladders (caged or other types) and Handrails	Ventilation
Lighting	Walkways/Roofing/Stairs/Gratings/Handrails
Liquid sampling and analytical work	Wireways/Wiring
Local control panels for blowers etc.	Yard Piping

© Copyright 2019 OVIVO. All rights reserved.

This document is confidential and shall remain the sole property of Ovivo. This document may not be reproduced or distributed without prior written approval of Ovivo. The data and information provided is furnished on a restricted basis and is not to be used in any way detrimental to the interests of Ovivo.

THIS BUDGETARY PROPOSAL CONSTITUTES A NON-BINDING ESTIMATE OF PRICE(S) FOR CERTAIN GOODS AND/OR SERVICES THAT MAY BE PROVIDED BY OVIVO USA LLC FROM TIME TO TIME, BUT SHALL NOT BE CONSTRUED AS A CONTRACTUAL OFFER FOR OVIVO USA LLC TO PROVIDE SUCH GOODS AND/OR SERVICES. ANY CONTRACTUAL OFFER FOR THE SUPPLY OF GOODS AND/OR SERVICES BY OVIVO USA LLC SHALL BE CONVEYED TO CUSTOMER IN THE FORM OF OVIVO USA LLC'S STANDARD PROPOSAL DOCUMENT, WHICH INCLUDES, BUT IS NOT LIMITED TO, ITS STANDARD TERMS AND CONDITIONS OF SALE. SUCH PROPOSAL FORM MAY BE PROVIDED TO CUSTOMER UPON REQUEST.

**ADDITIONAL ITEMS BY INSTALLING CONTRACTOR**

- 1 Obtain necessary construction permits and licenses, construction drawings (including interconnecting piping drawings) field office space, telephone service, and temporary electrical service.
- 2 All site preparation, grading, locating foundation placement, excavation for foundation, underground piping, conduits and drains.
- 3 Demolition and/or removal of any existing structures, equipment or facilities required for construction and installation of the AnammoPAQ® system.
- 4 Installation of all foundation - supply and installation of all embedded or underground piping, conduits and drains.
- 5 All backfill, compaction, finish grading, earthwork and final paving.
- 6 Receiving (preparation of receiving reports), unloading, storage, maintenance preservation and protection of all equipment and materials supplied by Ovivo.
- 7 Installation of all equipment and materials supplied by Ovivo.
- 8 Supply, fabrication, installation, cleaning, pickling and/or passivation of all interconnecting steel piping components.
- 9 Provide and install all embedded pipe sections and valves for tank drains and reactor inlets and elbows.
- 10 All cutting, welding, fitting and finishing for all field fabricated piping.
- 11 Supply and installation of all flange gaskets and bolts for all piping components.
- 12 Supply and installation of all pipe supports and wall penetrations.
- 13 Install and provide all motor control centers, motor starters, panels, field wiring, wireways, supports and transformers.
- 14 Install all control panels and instrumentation as supplied by Ovivo, as applicable.
- 15 Supply and install all electrical power and control wiring and conduit to the equipment served plus interconnection between the Ovivo equipment as required, including wire, cable, junction boxes, fittings, conduit, cable trays, safety disconnect switches, circuit breakers, etc.
- 16 Supply and install all insulation, supports, drains, gauges, hold down clamps, condensate drain systems, flanges, flex pipe joints, expansion joints, boots, gaskets, adhesives, fasteners, safety signs, and any specialty items such as traps.
- 17 All labor, materials, supplies and utilities as required for start-up including laboratory facilities and analytical work.
- 18 Provide all chemicals required for plant operation and all chemicals, lubricants, glycol, oils or grease and other supplies thereafter.

© Copyright 2019 OVIVO. All rights reserved.

This document is confidential and shall remain the sole property of Ovivo. This document may not be reproduced or distributed without prior written approval of Ovivo. The data and information provided is furnished on a restricted basis and is not to be used in any way detrimental to the interests of Ovivo.

THIS BUDGETARY PROPOSAL CONSTITUTES A NON-BINDING ESTIMATE OF PRICE(S) FOR CERTAIN GOODS AND/OR SERVICES THAT MAY BE PROVIDED BY OVIVO USA LLC FROM TIME TO TIME, BUT SHALL NOT BE CONSTRUED AS A CONTRACTUAL OFFER FOR OVIVO USA LLC TO PROVIDE SUCH GOODS AND/OR SERVICES. ANY CONTRACTUAL OFFER FOR THE SUPPLY OF GOODS AND/OR SERVICES BY OVIVO USA LLC SHALL BE CONVEYED TO CUSTOMER IN THE FORM OF OVIVO USA LLC'S STANDARD PROPOSAL DOCUMENT, WHICH INCLUDES, BUT IS NOT LIMITED TO, ITS STANDARD TERMS AND CONDITIONS OF SALE. SUCH PROPOSAL FORM MAY BE PROVIDED TO CUSTOMER UPON REQUEST.



- 19 Install all anchor bolts and mounting hardware supplied by Ovivo; and supply and install all anchor bolts and mounting hardware not specifically supplied by Ovivo.
- 20 Provide all nameplates, safety signs and labels.
- 21 Provide all additional support beams and/or slabs.
- 22 Provide and install all manual valves.
- 23 Provide and install all piping required to interconnect to the Ovivo's equipment.
- 24 The Contractor shall coordinate the installation and timing of interface points such as piping and electrical with the Ovivo Supplier.

***All other necessary equipment and services not otherwise listed as specifically supplied by Ovivo.***

## BUDGET PRICE

Our current budget estimate price for the AnammoPAQ® system, as described in this proposal is:

Description	Price
AnammoPAQ® system as described above	<b>As Advised by Rep</b> <b>\$3,023,000</b>

### NOTES –

1. Our Price and Payment Terms are based on Ovivo's standard terms and conditions, which can be provided upon request.
2. This price will be valid for thirty (30) days.
3. All prices are excluding Washington state sales and use taxes and any federal taxes which shall be the sole responsibility of the Client. No additional duties will have to be paid for the equipment supplied by Ovivo.
4. Pricing is subject to the London Metal exchange index for stainless steel rolled coil calculated from the original proposal date and is in accordance with the Scope of Supply and terms of this proposal and any changes may require the price to be adjusted.

### Shipping Terms

FOB Shipping Point, Full Freight Allowed

© Copyright 2019 OVIVO. All rights reserved.

This document is confidential and shall remain the sole property of Ovivo. This document may not be reproduced or distributed without prior written approval of Ovivo. The data and information provided is furnished on a restricted basis and is not to be used in any way detrimental to the interests of Ovivo.

THIS BUDGETARY PROPOSAL CONSTITUTES A NON-BINDING ESTIMATE OF PRICE(S) FOR CERTAIN GOODS AND/OR SERVICES THAT MAY BE PROVIDED BY OVIVO USA LLC FROM TIME TO TIME, BUT SHALL NOT BE CONSTRUED AS A CONTRACTUAL OFFER FOR OVIVO USA LLC TO PROVIDE SUCH GOODS AND/OR SERVICES. ANY CONTRACTUAL OFFER FOR THE SUPPLY OF GOODS AND/OR SERVICES BY OVIVO USA LLC SHALL BE CONVEYED TO CUSTOMER IN THE FORM OF OVIVO USA LLC'S STANDARD PROPOSAL DOCUMENT, WHICH INCLUDES, BUT IS NOT LIMITED TO, ITS STANDARD TERMS AND CONDITIONS OF SALE. SUCH PROPOSAL FORM MAY BE PROVIDED TO CUSTOMER UPON REQUEST.

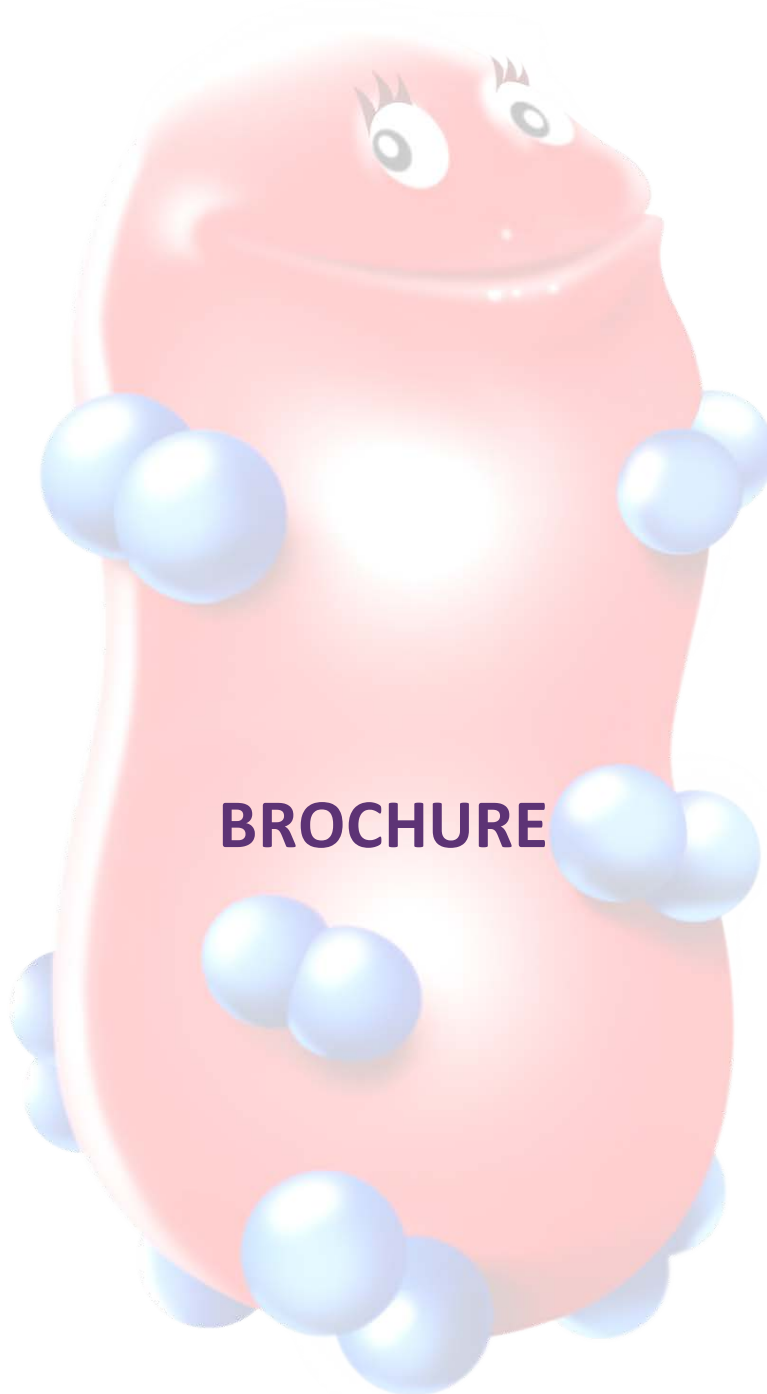

# BROCHURE

---

**© Copyright 2019 OVIVO. All rights reserved.**

This document is confidential and shall remain the sole property of Ovivo. This document may not be reproduced or distributed without prior written approval of Ovivo. The data and information provided is furnished on a restricted basis and is not to be used in any way detrimental to the interests of Ovivo

THIS BUDGETARY PROPOSAL CONSTITUTES A NON-BINDING ESTIMATE OF PRICE(S) FOR CERTAIN GOODS AND/OR SERVICES THAT MAY BE PROVIDED BY OVIVO USA LLC FROM TIME TO TIME, BUT SHALL NOT BE CONSTRUED AS A CONTRACTUAL OFFER FOR OVIVO USA LLC TO PROVIDE SUCH GOODS AND/OR SERVICES. ANY CONTRACTUAL OFFER FOR THE SUPPLY OF GOODS AND/OR SERVICES BY OVIVO USA LLC SHALL BE CONVEYED TO CUSTOMER IN THE FORM OF OVIVO USA LLC'S STANDARD PROPOSAL DOCUMENT, WHICH INCLUDES, BUT IS NOT LIMITED TO, ITS STANDARD TERMS AND CONDITIONS OF SALE. SUCH PROPOSAL FORM MAY BE PROVIDED TO CUSTOMER UPON REQUEST.

## OVIVO-PAQUES AnammoPAQ® PROCESS

### SUSTAINABLE NITROGEN REMOVAL

#### HOW WE CREATE VALUE

Cost-effective nitrogen removal from digester sidestreams (with or without THP) using Anammox

Compared to conventional nitrification and denitrification:

- 60% energy savings compared
- 100% reduction in supplemental organic carbon
- 90% reduction in sludge production
- 90% reduction in footprint
- 85% reduction in CO<sub>2</sub> emissions

Quick startup time with potential for full process optimization within 3 weeks

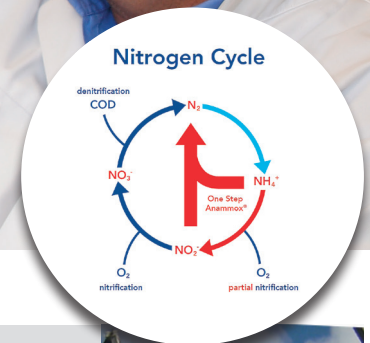

#### THE CHALLENGE

- Despite representing 1% to 3% of the flow to the mainstream, typical anaerobic digester sidestream contains 10% to 30% of the nitrogen load, with concentrations often in excess of 1,000 mg/L ammonia-N
- Sludge pre-treatment with THP can double the ammonia-N concentrations in the sidestream
- Stringent BNR limits on main stream
- Conventional nitrification and denitrification requires significant aeration energy and supplemental carbon

#### THE OVIVO SOLUTION

The AnammoPAQ® process is an elegant shortcut in the natural nitrogen cycle. The process utilizes Anammox bacteria which directly convert ammonium (NH<sub>4</sub><sup>+</sup>) and nitrite (NO<sub>2</sub><sup>-</sup>) into nitrogen gas. Paques B.V. developed the original process for commercial purposes in cooperation with Delft University of Technology and the University of Nijmegen. Since the first full-scale plant started up in 2002 (treatment of sidestream from sludge digestion), many other plants have been installed and are running successfully.

#### The AnammoPAQ® ADVANTAGE

- Proven technology with 15+ years operational experience
- 65+ AnammoPAQ® references worldwide including North America
- Largest single unit can handle 10 metric tons of nitrogen/day (equivalent to sidestream from a 250 MGD municipal plant)!
- Robust system, handling high loading variations
- Up to 60% saving on operational costs
- Savings on excess sludge production
- No addition of organic carbon source (methanol) required
- Production of valuable Anammox biomass
- High loading rates leading to compact footprint
- Lowest O&M amongst competing systems



## OPERATING PRINCIPLE

AnammoPAQ® technology is a continuous flow reactor system in which nitrification and anammox conversion occur simultaneously in a single process unit. Anammox (anaerobic ammonium oxidation) conversion is an elegant short-cut in the natural nitrogen cycle where ammonium and nitrite are converted to nitrogen gas. As the Anammox process involves removal of ammonium over nitrite (NO<sub>2</sub><sup>-</sup>) rather than nitrate (NO<sub>3</sub><sup>-</sup>), 63% less oxygen (O<sub>2</sub>) is required while eliminating the need for an external carbon source altogether. Optimal process control ensures retention of AOBs and Anammox bacteria while eliminating NOBs, leading to stable & robust operation.

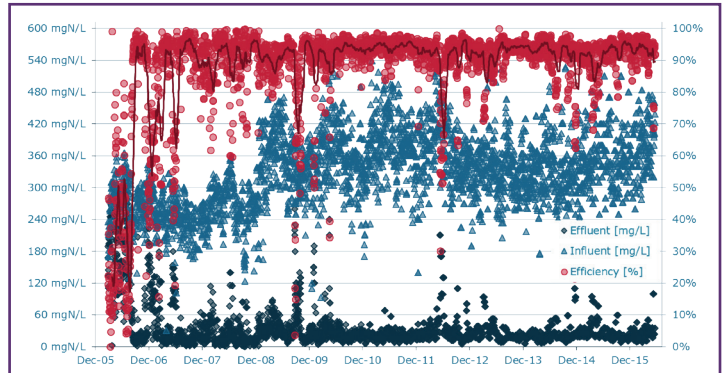
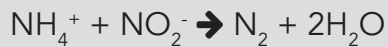

The Olburgen WWTP in Netherlands, with the Ovivo AnammoPAQ® process has reached stable & continuous 92% ammonium and 85% total nitrogen removal average for over 10 years

## HOW IT WORKS

- 1 Ammonia-rich influent
- 2 Aerators for mixing and ammonia removal process
- 3 AnammoPAQ® separator for biomass retention
- 4 Effluent exits the reactor

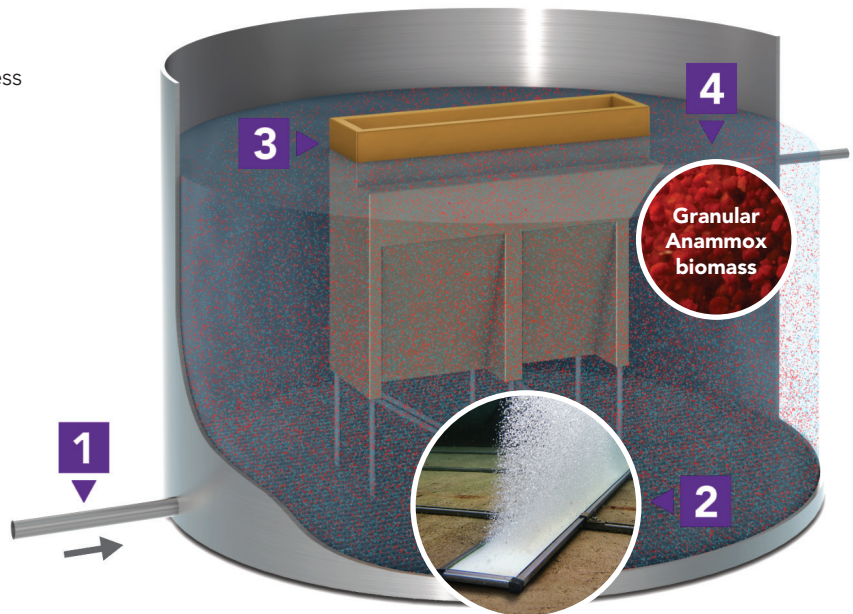

## CONTACT

1-855-GO-OVIVO ☎  
info@ovivowater.com ✉  
www.ovivowater.com 🌐





Proposal  
Brightwater, WA

ANITA™ Mox

Proj. No. 5700147913

Submitted to: Matt Winkler, PE  
Brown and Caldwell

Submitted by: Ashley Waples  
Application Engineer

Date: 12/30/2019

*This document is confidential and may contain proprietary information.  
It is not to be disclosed to a third party without the written consent of Veolia Water Technologies.*

**Veolia Water Technologies Inc. (dba Kruger)**  
4001 Weston Parkway  
Cary, NC 27513  
tel. +1 919-677-8310 • fax +1 919-677-0082  
[www.veoliawatertech.com](http://www.veoliawatertech.com)

**Water Technologies**

## Introduction

Kruger (a subsidiary of Veolia Water Technologies) is pleased to present this budgetary proposal for our ANITA™ Mox process for deammonification of centrate at Brightwater WWTP in King County, Washington. We recommend constructing two (2) ANITA Mox MBBR process trains using our AnoxK™5 media. This design is based upon the information we have received from you. The influent design criteria are summarized in Table 1. The tank dimensions along with other important process parameters are summarized in Table 3.

It is important that each reactor have the capability for independent control of influent feed and aeration. This can be accomplished through dedicated pumps and blowers or by using high performance modulating valves. We have included one (1) modulating airflow control valve per train as part of Kruger's scope to meet this need.

We appreciate the opportunity to provide this proposal to you. If you have any questions or need further information, please contact our local Representative, Bill Reilly of Wm. H. Reilly, or our Regional Sales Manager, Brad Mrdjenovich, at (919)-653-4531 ([brad.mrdjenovich@veolia.com](mailto:brad.mrdjenovich@veolia.com)).

cc: LL, BM, GAT, JY, project file (Kruger)

Revision	Date	Process Eng.	Comments
0	12/12/2019	JLY	Initial, budgetary proposal.





---

## We Know Water

Kruger is a water and wastewater solutions provider specializing in advanced and differentiating technologies. Kruger provides complete processes and systems ranging from biological nutrient removal to mobile surface water treatment. The ACTIFLO® Microsand Ballasted Clarifier, BioCon® Dryer, BIOSTYR® Biological Aerated Filter (BAF) and NEOSEP™ MBR are just a few of the innovative technologies offered. Kruger is a subsidiary of Veolia Water, a world leader in engineering and technological solutions in water treatment for industrial companies and municipal authorities.

**Veolia Water Technologies**, the fully-owned subsidiary of **Veolia Water**, is the world leader in water and wastewater treatment with over 155 years of experience. As an experienced design-build company and a specialized provider of technological solutions in water treatment, Veolia combines proven expertise with unsurpassed innovation to offer technological excellence to our industrial customers. Based on this expertise, we believe that we have developed the best solution for your application. Below is a brief description of the proposed project.

## Energy Focus

Kruger, along with Veolia Water Technologies (VWT) is dedicated to delivering sustainable and innovative technologies and solutions.

We offer our customers integrated solutions which include resource-efficient technology to improve operations, reduce costs, achieve sustainability goals, decrease dependency on limited resources, and comply with current and anticipated regulations.

Veolia's investments in R&D outpace that of our competition. Our focus is on delivering

- neutral or positive energy solutions
- migration towards green chemicals or zero chemical consumption
- water-footprint-efficient technologies with high recovery rates

Our carbon footprint reduction program drives innovation, accelerates adoption and development of clean technologies, and offers our customers sustainable solutions.

Kruger is benchmarking its technologies and solutions by working with our customers and performing total carbon cost analysis over the lifetime of the installation.

By committing to the innovative development of clean and sustainable technologies and solutions worldwide, Kruger and VWT will continue to maximize the financial benefits for every customer.



## We Know Smart Water Management

Veolia is the only company in the world that can combine decades of water treatment expertise, process knowledge and our wide range of domestic and global references into a comprehensive digital solutions platform that provides numerous opportunities to enhance the management of water.



When AQUAVISTA™ is paired with process and equipment instrumentation, your facility will have access to the most advanced suite of cloud-based monitoring, control and technical support mechanisms in the industry. AQUAVISTA™ provides the opportunity to improve your plant's overall performance with enhancements in operational efficiencies and critical asset management. AQUAVISTA™ runs on today's most secure cloud based services and is fully accessible with any common smart devices (phone, pad, tablet).

Four (4) tiers of service are available:

- Portal: A remote monitoring and reporting tool with overview of all plant data and access to important facility documentation.
- Insight: Portal + Data driven performance optimization advice regarding the general status and operational conditions of your plant.
- Assist: Added level of access to Veolia's process experts for process, maintenance, and training support.
- Plant: Operator adjustable levels of automatic control of your treatment facility.

All levels of service provide a simple link to Veolia's customer service group to facilitate easy access to spare parts and other service needs.



## Process Description

### AnoxKaldnes MBBR

The MBBR process is a continuous-flow, non-clogging biofilm reactor containing moving “carrier elements” or media. The media flows with the water currents in the reactor and does not require backwashing or cleaning.

The biomass that treats the wastewater is attached to the surfaces of the media. The media is designed to provide a large protected surface area for the biofilm and optimal conditions for biological activity when suspended in water. AnoxKaldnes media is made from polyethylene and has a density slightly less than water.

The ANITA™ Mox process is a single-stage nitrogen removal process based on the MBBR platform. The process is specifically designed for treatment of waste streams with high ammonia concentrations. The system can achieve ammonia removals of up to 80-90% and total nitrogen removals of up to 75-85%. The treatment method uses only 40% of the oxygen demand of conventional nitrification, and it requires no external carbon source.

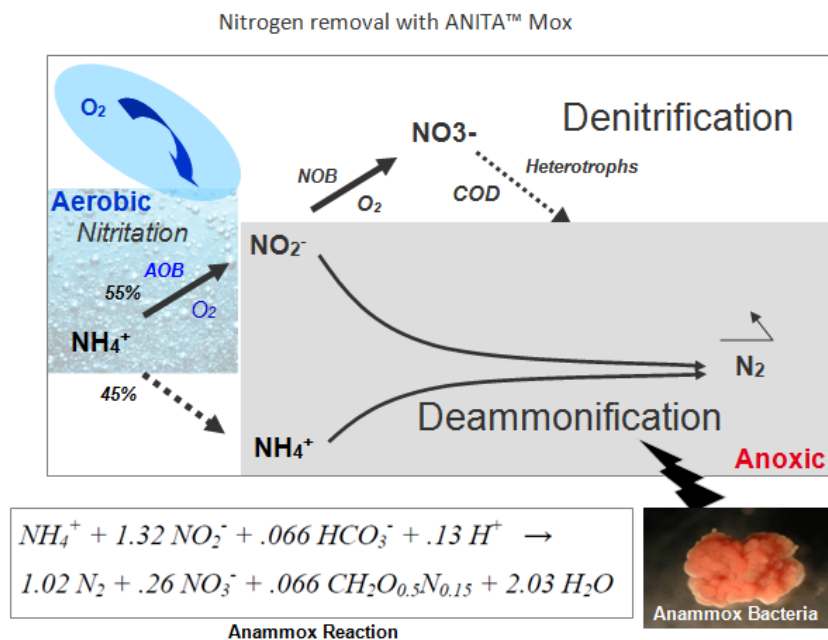

The ANITA Mox process consists of an aerobic nitritation reaction and an anoxic ammonia oxidation (anammox) reaction. The two steps take place simultaneously in different layers of the biofilm. Nitritation occurs in the outer layer of the biofilm. Approximately 55% of the influent ammonia is oxidized to nitrite (NO<sub>2</sub><sup>-</sup>). Anammox activity occurs in the inner layer. In this step, the nitrite produced and the remaining ammonia are utilized by the anammox bacteria and converted to nitrogen gas (N<sub>2</sub>) and a small amount of nitrate (NO<sub>3</sub><sup>-</sup>).



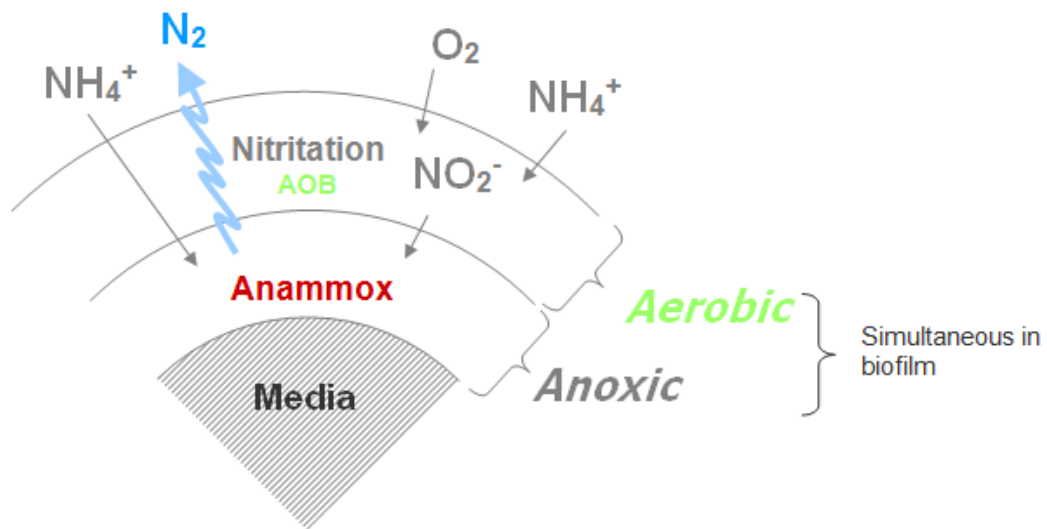

The aerobic and anoxic reactions occur in a single MBBR reactor. The combined biomass grows attached to the AnoxKaldnes media and is retained in the reactor by media screens. This biomass retention is an important characteristic of the system, since the anammox bacteria growth rate is very slow when compared to conventional wastewater bacteria growth rates.



## AnoxKaldnes ANITA™ Mox System Configuration

Kruger proposes the ANITA™ Mox process for deammonification of centrate at Brightwater WWTP in King County, Washington. We recommend constructing two (2) ANITA Mox MBBR process trains using our AnoxK™5 media.

Kruger's scope of supply includes the AnoxKaldnes media, screen assemblies (to keep media in each reactor), medium bubble aeration grids, mixers, instrumentation and controls.

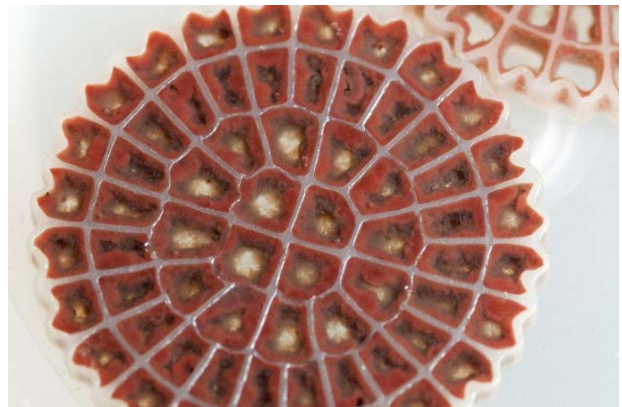

## Design Summary

The design assumes that the side stream entering into the proposed ANITA Mox system contains no toxic compounds and has sufficient alkalinity and that none of the equipment provided would be used in a classified area (e.g. Class 1, Division 1 or Class 1, Division 2).

The ANITA Mox influent design basis is summarized in Table 1. The target effluent criteria for the ANITA Mox system are listed in Table 2. The process design is summarized in Table 3.

Our design approach is to construct all new tanks. Given this constraint, we have estimated the ammonia removal capacity of the reactors without any alkalinity addition using our proprietary design tools. According to this method, the system achieves an estimated 80 - 85% NH<sub>4</sub>-N removal. In practice, it is possible the observed removals will exceed this estimate, if the wastewater characteristics are favorable.

**Table 1: Influent Design Basis**

Parameter	Units	Values
Flow, Design	MGD	0.186
BOD <sub>5</sub> , Design Flow*	mg/L	160
COD, Design Flow*	mg/L	570
TSS, Design Flow	mg/L	500
TKN, Design Flow	mg/L	1,270
NH <sub>4</sub> -N, Design Flow	mg/L	1,150
Alkalinity, Design Flow**	mg/L	4,500
Elevation	ft	40
Minimum Temperature	°C	30.0

\*Assumed values from typical centrate composition

\*\*TSS concentrations to ANITA Mox < 1,500 mg/L ave. and 20,000 mg/L peak do not require centrate sedimentation

**Table 2: Target Effluent Concentrations**

Parameter	Units	Value
NH <sub>4</sub> -N	mg/L	< 230
Total Inorganic Nitrogen	mg/L	< 330



**Table 3: Process Design Summary**

Parameter	Units	Values
Number of Process Trains	-	2
Reactor Dimensions (Each)*	ft	32 L × 21 W × 21 SWD
Reactor Volume (Each)	ft <sup>3</sup>	14,112
Reactor Volume (Total)**	ft <sup>3</sup>	28,224
Recommended Freeboard for all reactors	ft	2 – 3
Media Type:	-	AnoxK™5
Fill of Biofilm Carriers, All Reactors	%	46
Media Volume (All Reactors)	ft <sup>3</sup>	13,162
Aeration System Type	-	Medium Bubble
Residual DO, Design	mg/L	1.5
Estimated Process Air Requirement, Design	SCFM	~1,090
Pressure (At Top of Drop Pipe)	psig	8.5

\*Reactor geometries can be modified as necessary to accommodate site conditions

\*\* Typically SWD ≥ 10' when considering retrofitting existing volumes.





---

## Scope of Supply

Kruger is pleased to present our scope of supply which includes process engineering design, equipment procurement, and field services required for the proposed treatment system, as related to the equipment specified. The work will be performed to Kruger's high standards under the direction of a Project Manager. All matters related to the design, installation, or performance of the system shall be communicated through the Kruger representative giving the Engineer and Owner ready access to Kruger's extensive capabilities.

### **Process and Design Engineering**

Kruger will provide process engineering and design support for the system as follows:

- Process Engineering consisting of aeration system sizing and configuration, sieve and outlet design.
- Review and approval of P&I Diagram for the AnoxKaldnes ANITA Mox portion of the process. Preliminary General Arrangement Drawings and review and approval of final General Arrangement Drawings for the process. Review of reactor drawings with respect to penetrations and dimensions, excluding structural design.
- Equipment installation instructions for all equipment supplied by Kruger.

### **Field Services**

Kruger will furnish a Service Engineer to perform the following tasks:

- Inspect installation of key pieces of equipment during construction.
- Inspect the completed system prior to startup.
- Assist the Contractor with initial startup of the system.
- Train the Owner's staff in the proper operation and maintenance of the AnoxKaldnes ANITA Mox system.
- Test and start any Kruger-supplied control equipment, including PLC programming and SCADA systems.



## AnoxKaldnes ANITA™ Mox System Equipment

Mechanical Equipment Items	Qty	Description
AnoxKaldnes AnoxK™5 Media, (ft <sup>3</sup> )	13,162	Carrier elements are made of high density polyethylene. The total media quantity will include a volume of ~5% seeded media.
Cylindrical Screen Assemblies	4	Two (2) per reactor. 304L SS. 23"ø perforated plate pipes terminated in ANSI flanges for mounting directly to the tank wall.
Medium Bubble Aeration System	6	Three (3) air grids per reactor. 304L SS including header, lateral piping, and hardware (excluding concrete anchor bolts).
Specially Designed Mechanical Mixers	2	One (1) per ANITA Mox Reactor. Includes VFD.
Airlift Pump	6	Three (3) airlift pumps per ANITA Mox reactor for foam suppression.
Modulating Airflow Control Valves	2	One (1) actuated BFV for each aerobic reactor.

Instrumentation and Controls Equipment Items	Qty	Description
PLC Control Panel	1	NEMA 12 Freestanding or Wall Mount Control Panel (For Indoor Use). ControlLogix PLC; Panelview HMI; 120V Feed
pH-based Control Logic	1	For an additional mode of airflow control to optimize available alkalinity
High Level Float Switch	2	One (1) for each media zone.
DO Probe (LDO)	2	One (1) for each Aerobic zone. Aerobic Zone DO Monitoring
pH meter	2	One (1) pH meter for each ANITA Mox reactor.
Influent Ammonia Nitrogen Probe	1	One (1) ammonia nitrogen probe for all process trains
Combination Ammonia / Nitrate Nitrogen Probes	2	One (1) combination ammonia / nitrate nitrogen probe for each ANITA Mox reactor.
Thermal Mass Flowmeter	2	One (1) for each ANITA Mox reactor for air flow control
Magnetic Flowmeter	2	One (1) magnetic flow meter per reactor to measure influent flow.
Instrumentation and Controls (NOT INCLUDED)*	Qty	Description
Centrate Feed Pump	2+1	Kruger can include these after hydraulics are known. Two (2) duty plus one (1) standby to feed centrate from equalization tank. Requires VFD.



## Notes Regarding System Design and Installation

- A note on concrete specifications: For any MBBR or IFAS system, regardless of manufacturer, it is sound practice to require good, quality concrete work for the process reactors. The Consulting Engineer's standard concrete specification section is typically adequate to eliminate large holes, excessive form marks, large pockets, and excessively rough areas. It is particularly important to eliminate the potential for annular space around media retention screens.
- A note on construction sequencing: It is important, particularly for IFAS installations, to have level detection and level communication systems in place and operational prior to the filling of process tanks with water and media.

## Scope of Supply BY INSTALLER/PURCHASER

The scope of supply by others for the AnoxKaldnes ANITA™ Mox system should include, but is not limited to, the following items:

- All civil/site and electrical work.
- A concrete foundation for the tanks.
- Reactors to house the MBBR treatment equipment.
- All provisions for interconnecting piping.
- Unloading, storage and installation of equipment.
- Install and test all level floats, level transmitters, level alarms, and alarm communication devices prior to filling a process tank with media and water
- Centrate equalization tanks
- Cover for reactor tanks (if necessary)
- Temporary provisions for screened primary or secondary effluent during startup.
- Temporary reactor heating during startup.
- Mixer bridges and other structural modifications for the reactors.
- Video recording of any training activities.

## Design Options

In addition to the proposed system as detailed herein, Kruger is able to further incorporate our process and controls expertise into wastewater treatment plants, allowing municipalities to meet stringent effluent requirements and future plant upgrades. Kruger is also able to offer our instrumentation and controls expertise to build upon the proposed system by providing a **customized plant-wide SCADA system** or designing a **Motor Control Center (MCC)**, providing clients a single source responsibility for plant controls. Please contact Kruger if the options above are of interest or to be included in the current proposed system or future upgrades. *\*\*Please note that the design options listed above are not included in the pricing noted herein.*



---

## Schedule

- Shop drawings will be submitted within 6-8 weeks of receipt of an executed contract by all parties.
- All equipment will be delivered within 18-20 weeks after receipt of written approval of the shop drawings.
- Installation manuals will be furnished upon delivery of equipment.
- Operation and Maintenance Manuals will be submitted within 90 days after receipt of approved shop drawings.

## Pricing

The price for the AnoxKaldnes ANITA™ Mox system, as defined herein, including process and design engineering, field services, and equipment supply is: **\$1,200,000**

Pricing is FOB shipping point, with freight allowed to the job site. This pricing does not include any sales or use taxes. In addition, pricing is valid for ninety (90) days from the date of issue.

***Please note that the above pricing is expressly contingent upon the items in this proposal and are subject to Kruger's Standard Terms of Sale detailed herein.***

### **Kruger Standard Terms of Payment**

The terms of payment are as follows:

- 10% on receipt of fully executed contract
- 15% on submittal of shop drawings
- 75% on the delivery of equipment to the site

Payment shall not be contingent upon receipt of funds by the Contractor from the Owner. There shall be no retention in payments due to Kruger. All other terms per our Standard Terms of Sale are attached.

All payment terms are net 30 days from the date of invoice. Final payment not to exceed 120 days from delivery of equipment.



# Kruger Standard Terms of Sale

1. Applicable Terms. These terms govern the purchase and sale of the equipment and related services, if any (collectively, "Equipment"), referred to in Seller's purchase order, quotation, proposal or acknowledgment, as the case may be ("Seller's Documentation"). Whether these terms are included in an offer or an acceptance by Seller, such offer or acceptance is conditioned on Buyer's assent to these terms. Seller rejects all additional or different terms in any of Buyer's forms or documents.
  2. Payment. Buyer shall pay Seller the full purchase price as set forth in Seller's Documentation. Unless Seller's Documentation provides otherwise, freight, storage, insurance and all taxes, duties or other governmental charges relating to the Equipment shall be paid by Buyer. If Seller is required to pay any such charges, Buyer shall immediately reimburse Seller. All payments are due within 30 days after receipt of invoice. Buyer shall be charged the lower of 1 ½% interest per month or the maximum legal rate on all amounts not received by the due date and shall pay all of Seller's reasonable costs (including attorneys' fees) of collecting amounts due but unpaid. All orders are subject to credit approval.
  3. Delivery. Delivery of the Equipment shall be in material compliance with the schedule in Seller's Documentation. Unless Seller's Documentation provides otherwise, Delivery terms are F.O.B. Seller's facility.
  4. Ownership of Materials. All devices, designs (including drawings, plans and specifications), estimates, prices, notes, electronic data and other documents or information disclosed by Seller or prepared solely by Seller or Buyer or jointly by Seller and Buyer in connection with this Agreement, and all intellectual property rights therein, shall be and remain the confidential and proprietary property of Seller, whether or not patented by Seller ("Work Product"). Buyer hereby irrevocably assigns all rights in any Work Product to Seller. Seller grants Buyer a non-exclusive, non-transferable (except to a successor-in interest to the ownership of the Equipment), paid-up license to use the Work Product solely in connection with Buyer's use, operation, repair and maintenance of the Equipment at the Jobsite defined in this Agreement. Buyer may not disclose, share, transfer, or sell any such Work Product to third parties without Seller's prior written consent and such consent may be arbitrarily withheld. Buyer agrees not to resell, transfer or give any of the biologically colonized media or bacteria from the system to any party other than Seller or any of Seller's affiliates without the prior written consent of Seller for a period of fifteen (15) years from the effective date of this Agreement. Buyer shall not cultivate bacteria or use biomass carriers retrieved from the ANITA Mox system for any research or non-research purposes without prior written consent of the Seller. Any new developments, discoveries or inventions resulting from the operation of the ANITA Mox system in which the ANITA Mox process is a component or is in any way incorporated in whole or in part shall be owned solely by the Seller.
  5. Changes. Seller shall not implement any changes in the scope of work described in Seller's Documentation unless Buyer and Seller agree in writing to the details of the change and any resulting price, schedule or other contractual modifications. This includes any changes necessitated by a change in applicable law occurring after the effective date of any contract including these terms.
  6. Warranty. Subject to the following sentence, Seller warrants to Buyer that the Equipment shall materially conform to the description in Seller's Documentation and shall be free from defects in material and workmanship. The foregoing warranty shall not apply to any Equipment that is specified or otherwise demanded by Buyer and is not manufactured or selected by Seller, as to which (i) Seller hereby assigns to Buyer, to the extent assignable, any warranties made to Seller and (ii) Seller shall have no other liability to Buyer under warranty, tort or any other legal theory. If Buyer gives Seller prompt written notice of breach of this warranty within 18 months from delivery or 1 year from beneficial use, whichever occurs first (the "Warranty Period"), Seller shall, at its sole option and as Buyer's sole remedy, repair or replace the subject parts or refund the purchase price therefore. If Seller determines that any claimed breach is not, in fact, covered by this warranty, Buyer shall pay Seller its then customary charges for any repair or replacement made by Seller. Seller's warranty is conditioned on Buyer's (a) operating and maintaining the Equipment in accordance with Seller's instructions, (b) not making any unauthorized repairs or alterations, and (c) not being in default of any payment obligation to Seller. Seller's warranty does not cover damage caused by chemical action or abrasive material, misuse or improper installation (unless installed by Seller). THE WARRANTIES SET FORTH IN THIS SECTION ARE SELLER'S SOLE AND EXCLUSIVE WARRANTIES AND ARE SUBJECT TO SECTION 10 BELOW. SELLER MAKES NO OTHER WARRANTIES OF ANY KIND, EXPRESS OR IMPLIED, INCLUDING WITHOUT LIMITATION, ANY WARRANTY OF MERCHANTABILITY OR FITNESS FOR PURPOSE.
  7. Indemnity. Seller shall indemnify, defend and hold Buyer harmless from any claim, cause of action or liability incurred by Buyer as a result of third party claims for personal injury, death or damage to tangible property, to the extent caused by Seller's negligence. Seller shall have the sole authority to direct the defense of and settle any indemnified claim. Seller's indemnification is conditioned on Buyer (a) promptly, within the Warranty Period, notifying Seller of any claim, and (b) providing reasonable cooperation in the defense of any claim.
  8. Force Majeure. Neither Seller nor Buyer shall have any liability for any breach (except for breach of payment obligations) caused by extreme weather or other act of God, strike or other labor shortage or disturbance, fire, accident, war or civil disturbance, delay of carriers, failure of normal sources of supply, act of government or any other cause beyond such party's reasonable control.
  9. Cancellation. If Buyer cancels or suspends its order for any reason other than Seller's breach, Buyer shall promptly pay Seller for work performed prior to cancellation or suspension and any other direct costs incurred by Seller as a result of such cancellation or suspension.
  10. LIMITATION OF LIABILITY. NOTWITHSTANDING ANYTHING ELSE TO THE CONTRARY, SELLER SHALL NOT BE LIABLE FOR ANY CONSEQUENTIAL, INCIDENTAL, SPECIAL, PUNITIVE OR OTHER INDIRECT DAMAGES, AND SELLER'S TOTAL LIABILITY ARISING AT ANY TIME FROM THE SALE OR USE OF THE EQUIPMENT SHALL NOT EXCEED THE PURCHASE PRICE PAID FOR THE EQUIPMENT. THESE LIMITATIONS APPLY WHETHER THE LIABILITY IS BASED ON CONTRACT, TORT, STRICT LIABILITY OR ANY OTHER THEORY.
- Miscellaneous. If these terms are issued in connection with a government contract, they shall be deemed to include those federal acquisition regulations that are required by law to be included. These terms, together with any quotation, purchase order or acknowledgement issued or signed by the Seller, comprise the complete and exclusive statement of the agreement between the parties (the "Agreement") and supersede any terms contained in Buyer's documents, unless separately signed by Seller. No part of the Agreement may be changed or cancelled except by a written document signed by Seller and Buyer. No course of dealing or performance, usage of trade or failure to enforce any term shall be used to modify the Agreement. If any of these terms is unenforceable, such term shall be limited only to the extent necessary to make it enforceable, and all other terms shall remain in full force and effect. Buyer may not assign or permit any other transfer of the Agreement without Seller's prior written consent. The Agreement shall be governed by the laws of the State of North Carolina without regard to its conflict of laws provisions.



DATE: 17 December 2019  
**TO: Matt Winkler – Brown & Caldwell**  
 FROM: Daniel Thompson – World Water Works (WWW)  
 CC: Chandler Johnson, Praveen Yanamandra – WWW  
 Chris McCalib - TEC  
 RE: Information on DEMON® Process – Brightwater, WA – Rev0

Per your request for design and sizing for a DEMON® treatment system based on the **design criteria provided**, please find below our design summary based on the information provided. Below are some graphs showing the typical cycle of a DEMON® treatment system.

## 1. DEMON® TREATMENT PROCESS

Deammonification represents a short-cut in the N-metabolism pathway and comprises of 2 steps. About half the amount of ammonia is oxidized to nitrite and then residual ammonia and nitrite is anaerobically transformed to elementary nitrogen. See this shortcut in the diagram below. By using this process there is no excess oxygen required or external carbon source to achieve nitrogen removal.

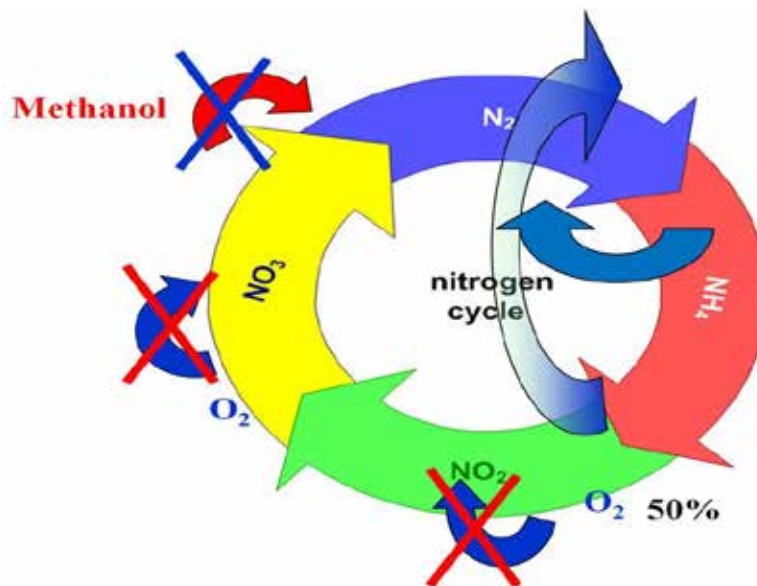

Figure 1 – NITROGEN CYCLE WITH SHORT CUT NITROGEN REMOVAL ADDED

Implementation of the University of Innsbruck pH controlled strategy for the DEMON® process for deammonification of reject water in a single sludge system is what this design is proposed around. The **specific energy demand of the side stream process results in 1.4 kWh per kg ammonia nitrogen removed comparing to about 6.5 kWh of mainstream treatment.** This process is achieving results of greater than 90% at the Strass WWTP (see data presented below). Biomass enrichment and Continuous Demon® -start up is key for this process to achieve its results in a short period of time and this proposal provides the seed sludge and start up assistance to ensure achieving the goal of efficient nitrogen removal.

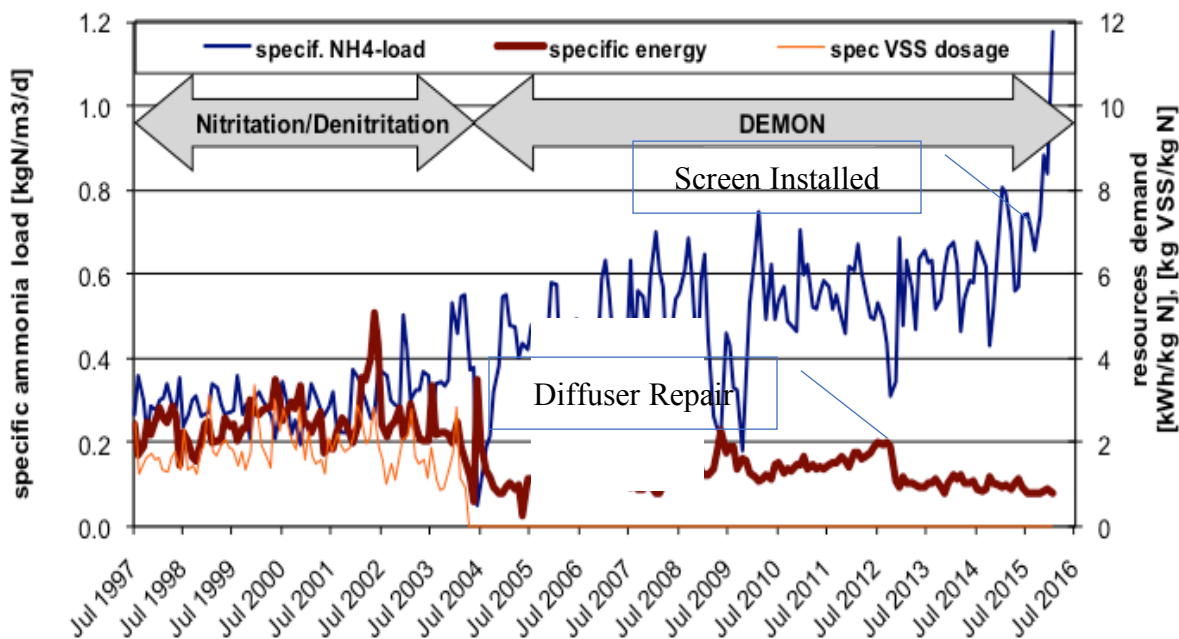

FIGURE 2 – STRASS NITROGEN PROFILE (1997 – 2016) WITH LOADING RATE AND SPECIFIC ENERGY



**Design Concept**

The overall design concept for is to use two (2) new reactors to create DEMON® treatment systems and a new EQ tank for the design conditions provided below. A second design condition is provided should only 1 reactor operate at the maximum month flow and loads.

<b>Parameter</b>	<b>MM – 2 tanks</b>	<b>MM – 1 tank</b>
TSS, mg/L	< 500	< 500
Soluble COD, mg/L	< 300	< 300
TKN, mg/L	1,146	1,146
Alkalinity, mg/L as CaCO <sub>3</sub>	4,000	4,000
Temp, °C	25-35	25-35
<b>Design Loading</b>	<b>1,778 lb/day</b>	<b>1,778 lb/day</b>
<b>Design Flow</b>	<b>0.186 MGD</b>	<b>0.186 MGD</b>

We envision using concrete tanks 23 ft long x 30 ft wide x 21 ft SWD for the Continuous DEMON® process. New mixers and aeration system will be placed in each reactor for providing the mixing energy for re-suspension of the granules, proper mixing distribution of the influent feed flow and provide the necessary aeration for nitrification. An internal settling zone will be used to settle out the MLSS / Anammox biomass and allow the treated wastewater to be discharged. A single control panel will be provided to control process.

<b>Parameter</b>	<b>MM – 2 tanks</b>	<b>MM – 1 tank</b>
Number of Trains	2	1
Length (ft)	23	23
Width (ft)	30	30
SWD (ft)	21	21
Air Flow (SCFM) / tank	268	402
Blower bHP / blower	19.5	15.2
Installed Blower HP	2 @ 30	2 @ 30

We see many advantages in operating the system as a continuous process as it will allow for a lower installed HP for the blowers and feed pumps, not require the Decanter and operate continuously with higher Anammox biomass retention which allows for higher operating loading rates.

Strass WWTP has been operating with a new Anammox retention system, which has proven to be very successful at allowing for higher Anammox retention then

We have designed the system based on having removal efficiencies of 90% for ammonia and 80% for TIN however the aeration system is sized based on 95% ammonia removal. We have also assumed minimum operating temperature of 25C. Below is a summary of the designs presented. Under design loads with influent ammonia loads for AM and MM listed above, the estimated effluent ammonia and total nitrogen using one (1) reactor are listed below

Parameter	MM – 2 tanks	MM – 1 tank
Effluent NH3-N (lb/day)	267	711
Effluent TIN (lb/day)	433	829

MM – 1 Tank design is for 60% removal of ammonia at a loading of 2.0 kg N/m<sup>3</sup>-day while the reactors settling zone is designed to handle the max month flow rate of 186,000 gpd.

**DEMON® TANK COMPONENTS**

- a) **Biomass Separation System** – A micro-screen will be used for this project and will have submerged pumps feeding it for a period time to waste out the AOB and NOB bacteria. The waste sludge of AOB and NOB bacteria will be discharged from the system while the underflow (Anammox bacteria) will be returned to the reactor.

Below are graphs of the loading and % removal of the Anammox treatment system at Strass WWTP in Austria using the microscreen since fall 2015. In February 2016, the specific load was increased to over 1.4 kg/m<sup>3</sup>-day while still maintaining greater than 90% removal of Ammonia-nitrogen.

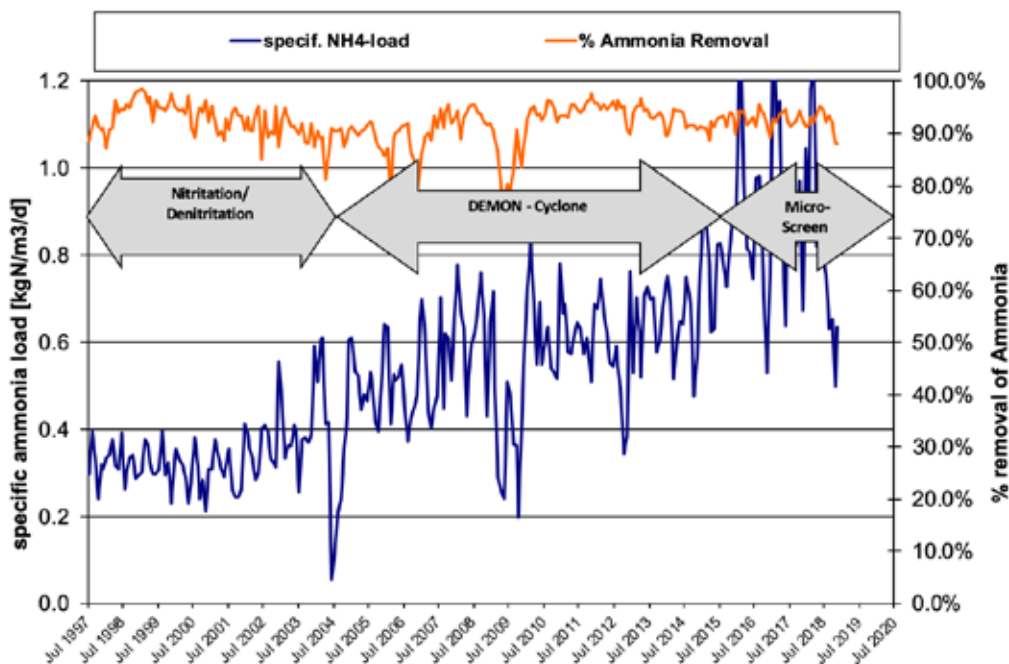

FIGURE 3 – AMMONIA LOAD AND PERCENT REMOVAL VS TIME (1997 – 2016)

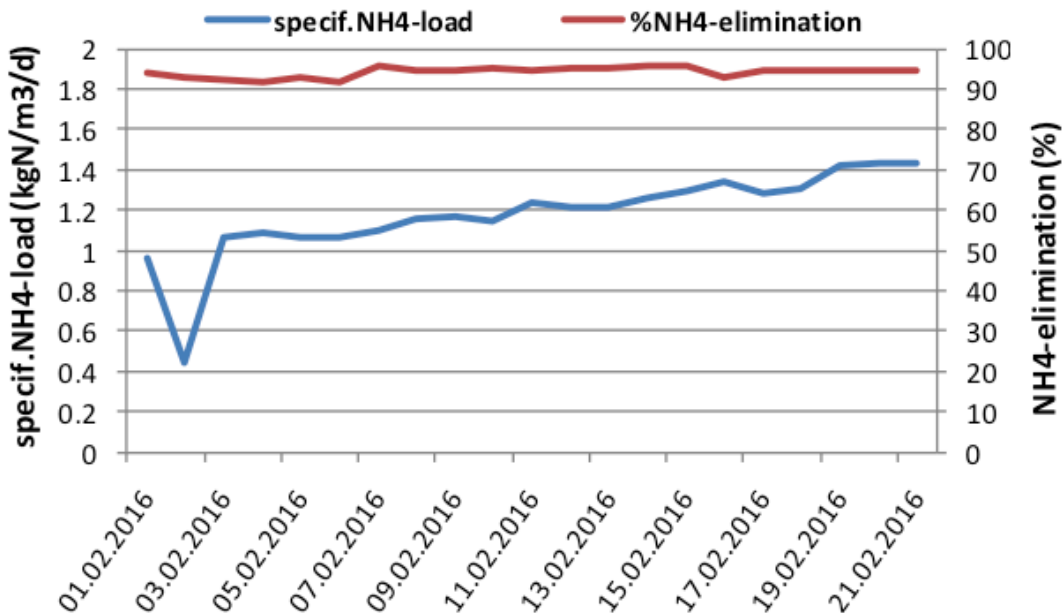

FIGURE 4 – SPECIFIC LOAD AND AMMONIA PERCENT REMOVAL – FEB 2016

- b) **Instrument Float** – the instruments for control of the process will be installed on a float system which will float with the level of the system. One (1) pH probe & one (1) DO probe for control of the overall operation of the process will be provided. A dedicated controller for the DO and pH is our recommendation. The conductivity probe is also to be provided with its own controller. Spare instrument locations will be provided in the instrument float for adding additional analyzers over time.



FIGURE 5 – INSTRUMENT FLOAT EQUIPMENT

- c) **Seed Sludge** – for the quick start-up of the DEMON® treatment process, an adequate amount of seed sludge will be supplied. The seed sludge will be shipped in as dry content possible based on the harvesting technique used and will be added to the systems as they are started up.



FIGURE 6 – SEED SLUDGE SHIPPING CONTAINER

- d) **Aeration System** – The Messner aeration system will be supplied in each tank. The amount of panels is provided in the scope of supply section and is subject to final design.



FIGURE 7 – MESSNER PANEL INSTALLED / AERATION PATTERN TEST

- e) **Side Mounted Mixers** – Landia side mounted mixers will be used to maintain mixing energy within each reactor. The mixers will help suspend the “reds” during the non-aerated cycles of the process. VFD’s will be provided to allow the mixers to be turned down and save on energy during the overall operation of the cycle.

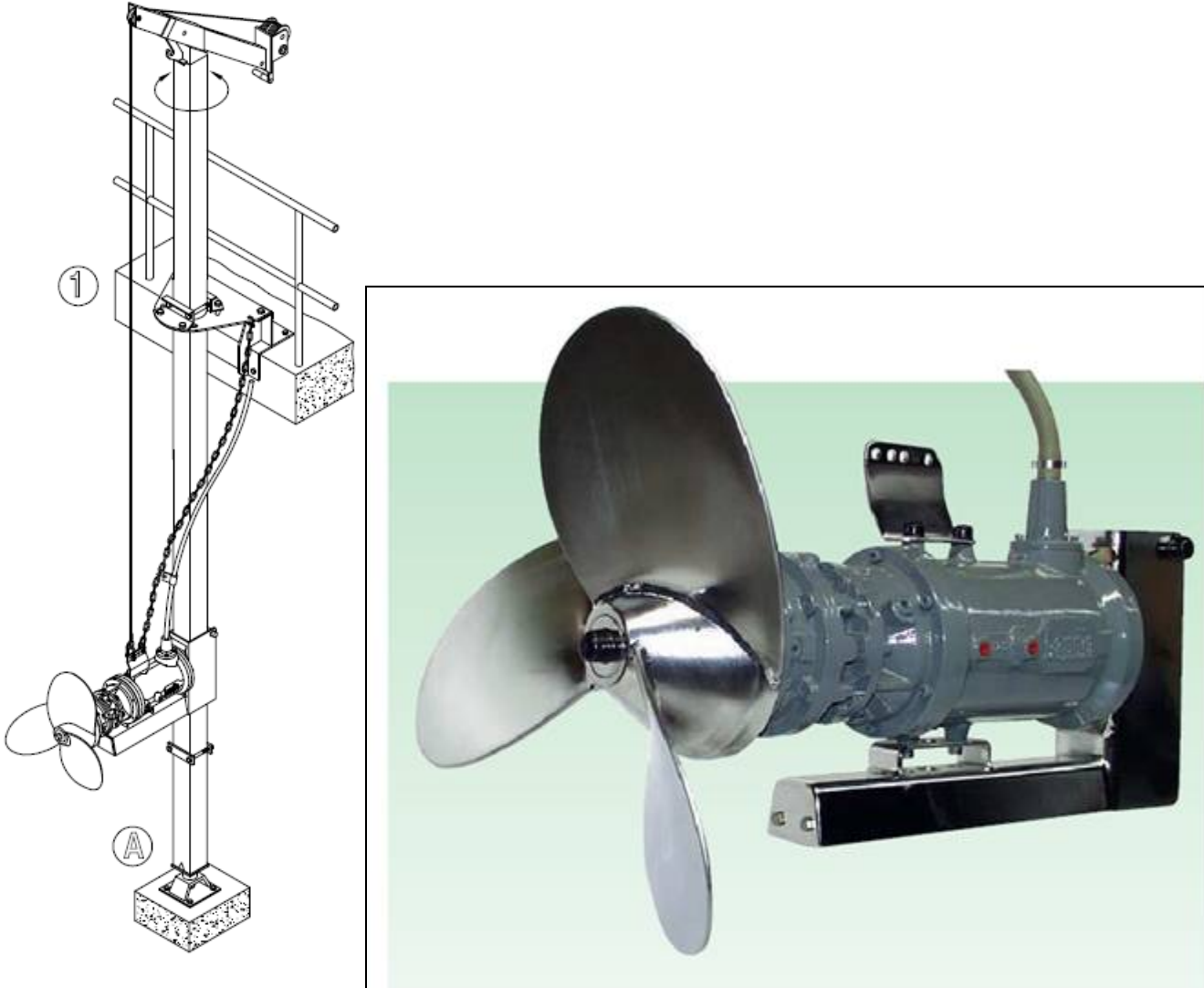
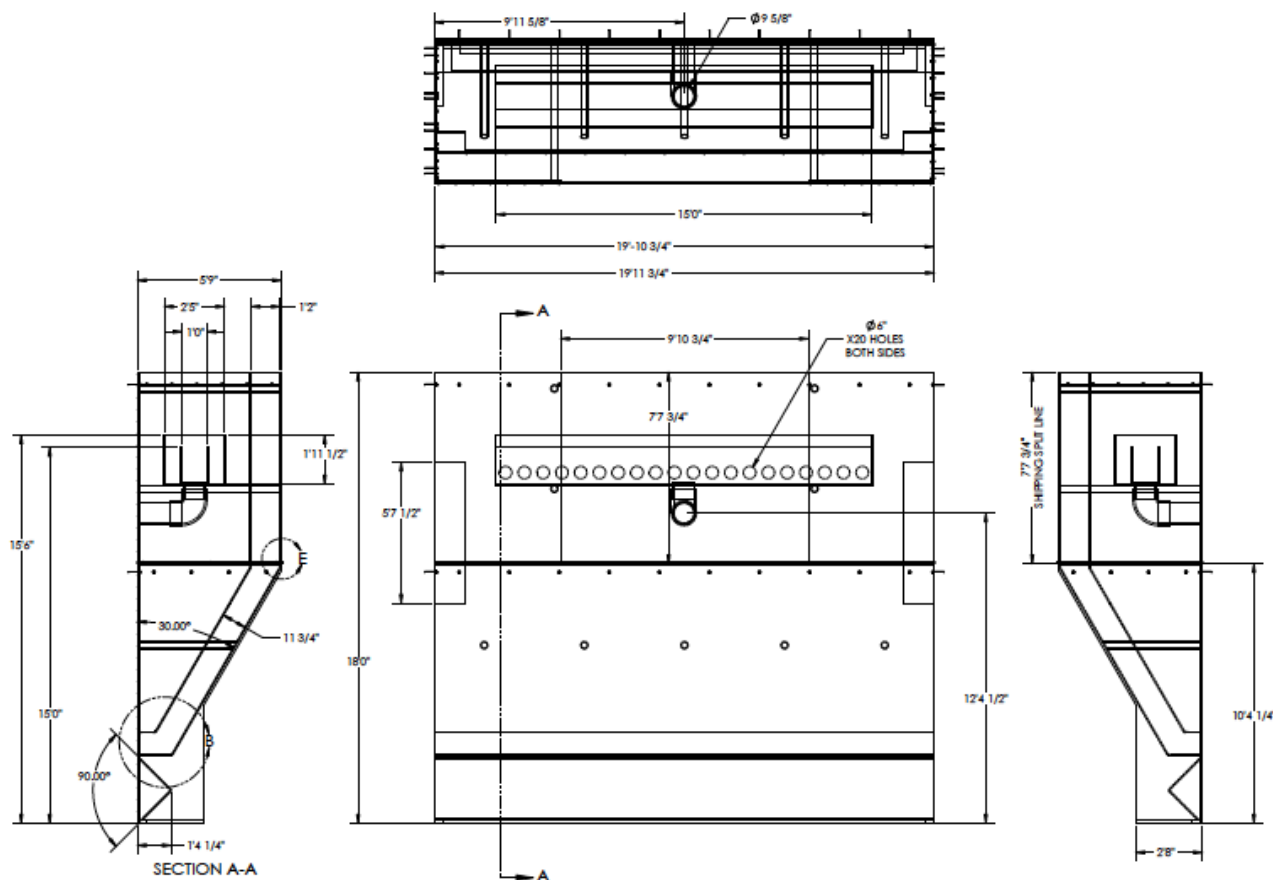

FIGURE 8 – LANDIA MIXER

- f) **Internal Settling Zone** – An internal settling zone will be provided to allow for a continuous operation of the Anammox treatment system. Clarified effluent will be discharged back into the main process while the settled MLSS will be returned to the Anammox reactor. The waste stream enters the vessel and immediately the velocity is reduced to enhance particle separation. The vessel is polypropylene, so the operating pH has no effect on the systems longevity. The “clean” liquid is continuously removed from the top of the settling area and passes through holes into an effluent collection piping system. From the effluent collection piping system, the wastewater gravity feeds out of the system. Heavy solids settle into the bottom where they fall back into the main DEMON® process tank on an automatic basis. The system is compact, robust, cleanable, and does not have moving parts.



**FIGURE 9 - View of the Settling Zone from Top, Front and back sides. To be anchored to outside and back concrete walls.**

g) **Blowers** – Positive displacement blowers capable of providing the necessary turndown for operation of the DEMON® system are to be provided.

<u>Design Case</u>	<u>Model</u>	<u>Air Flow</u>	<u>Est. HP</u>	<u>Est. bHP</u>
2 duty + 1 standby (1 per tank)	GM 10S	268 SCFM	30 HP	19.5 bHP – MM – 2 Tanks
2 duty + 1 standby (2 per tank)		402 SCFM		15.5 bHP – MM – 1 Tank

This blower design will allow the most flexibility in allowing the system have efficient use of blower capacity during start up and low load periods of time. The blowers will each have its own sound enclosure to maintain < 75 db sound rating. Each blower will also be equipped with a variable frequency drive unit to allow efficient turndown of the blower while maintaining the proper dissolved oxygen concentration in the DEMON® reactor.



FIGURE 10 – AERZEN BLOWER WITH SOUND ENCLOSURE

h) **Documentation / Design / License** – All necessary documentation and design information will be provided as well as a license for treating the Maximum Month Loads.



## 2. CONTROLS

World Water Works provides pre-wired control panels to optimally control all equipment provided within the scope of this proposal. World Water Works includes an Ethernet connection with the control panel to allow remote access to the program and to assist in troubleshooting.

### INSTRUMENTATION

Electrical Enclosure	<b>Hoffman, NEMA 4</b>
PLC	<b>Allen Bradley</b>
Software	<b>Allen Bradley</b>
Touchscreen	<b>15 inch Color Touch Screen</b>

### ADDITIONAL OPTIONS PROVIDED

**Remote Operation Capability**

**UL Listed Panel**



FIGURE 11 – CONTROL PANEL WITH PLC

**PLC Panel** – The PLC panel and control program is the heart of the DEMON® process and its integral to our scope of supply. The PLC program will have each reactor created as a separate reactor. The reactor will have independent feed of raw centrate, aeration and mixing time. A touch panel with remote access is standard for allowing WWW access to the system and provides operational oversight.

**DESIGN FOR 25C – MM – 2 Tanks**

<b>Influent Flow and Wastewater Characteristics</b>	<b>Design</b>		<b>Design</b>	
Wastewater temperature in DEMON® Anammox-tank	25	°C	77	F
Daily water flow	704	m <sup>3</sup> /d	0.186	MGD
Ammonia (NH <sub>4</sub> -N) Load	807	kg/d	1,778	lb/day
Ammonia (NH <sub>4</sub> -N) Concentration	1,146	mg/L	1,146	mg/L
Soluble COD, degradable (estimate)	300	mg/L	300	mg/L
Suspended Solids Concentration (TSS)	500	mg/L	500	mg/L
Soluble COD, degradable Load	211	kg/d	466	lb/day
Suspended Solids Load (TSS)	352	kg/d	776	lb/day
Alkalinity Concentration	4,000	mg/L	4,000	mg/L
Alkalinity Load	2,816	kg/d	6,209	lb/day
<b>DEMON® Anammox Tank Information</b>				
Number of tanks	2	in parallel	2	in parallel
Max. water depth	6.40	m	21.0	ft
Total volume per DEMON® Anammox Reactor	410	m <sup>3</sup>	14,465	ft <sup>3</sup>
Length of Each DEMON® Anammox Treatment Reactor	7.0	m	23	ft
Width of Each DEMON® Anammox Treatment Reactor	9.1	m	30	ft
Total Treatment Volume Provided	819	m <sup>3</sup>	28,930	ft <sup>3</sup>
<b>Influent Feeding Design</b>				
Feeding pump per tank	22	m <sup>3</sup> /h	95	gpm
<b>Design of aeration system</b>				
<b>Biological Oxygen Requirements System Design</b>				
Actual Oxygen Requirements (AOR), operating conditions	1,395	kg O <sub>2</sub> /d	3,075	lb O <sub>2</sub> /d
Actual Oxygen Required (AOR) in DEMON® Anammox tank	42	kg O <sub>2</sub> /h	92	lb O <sub>2</sub> /h
<b>Aeration System &amp; Blower Design Air Flow Requirements</b>				
Design Air Flow (per DEMON® Anammox-tank)	455	Nm <sup>3</sup> /h	268	SCFM
Design Air Flow (per ALL TANKS)	909	Nm <sup>3</sup> /h	535	SCFM

Air flows are based on 21 ft operating water level and discharge pressure of 10.5 psig

Rough Footprint would be two (2) basins at 30 ft wide x 23 ft long x 21 ft SWD.

**DESIGN FOR 25C – MM – 1 Tank**

<b>Influent Flow and Wastewater Characteristics</b>	<b>Design</b>		<b>Design</b>	
Wastewater temperature in DEMON® Anammox-tank	25	°C	77	F
Daily water flow	704	m <sup>3</sup> /d	0.186	MGD
Ammonia (NH <sub>4</sub> -N) Load	807	kg/d	1,778	lb/day
Ammonia (NH <sub>4</sub> -N) Concentration	1,146	mg/L	1,146	mg/L
Soluble COD, degradable (estimate)	300	mg/L	300	mg/L
Suspended Solids Concentration (TSS)	500	mg/L	500	mg/L
Soluble COD, degradable Load	211	kg/d	466	lb/day
Suspended Solids Load (TSS)	352	kg/d	776	lb/day
Alkalinity Concentration	4,000	mg/L	4,000	mg/L
Alkalinity Load	2,816	kg/d	6,209	lb/day
<b>DEMON® Anammox Tank Information</b>				
Number of tanks	1	in parallel	1	in parallel
Max. water depth	6.40	m	21.0	ft
Total volume per DEMON® Anammox Reactor	410	m <sup>3</sup>	14,465	ft <sup>3</sup>
Length of Each DEMON® Anammox Treatment Reactor	7.0	m	23	ft
Width of Each DEMON® Anammox Treatment Reactor	9.1	m	30	ft
Total Treatment Volume Provided	410	m <sup>3</sup>	14,465	ft <sup>3</sup>
<b>Influent Feeding Design</b>				
Feeding pump per tank	39	m <sup>3</sup> /h	172	gpm
<b>Design of aeration system</b>				
<b>Biological Oxygen Requirements System Design</b>				
Actual Oxygen Requirements (AOR), operating conditions	1,047	kg O <sub>2</sub> /d	2,307	lb O <sub>2</sub> /d
Actual Oxygen Required (AOR) in DEMON® Anammox tank	62	kg O <sub>2</sub> /h	137	lb O <sub>2</sub> /h
<b>Aeration System &amp; Blower Design Air Flow Requirements</b>				
Design Air Flow (per DEMON® Anammox-tank)	683	Nm <sup>3</sup> /h	402	SCFM

Air flows are based on 21 ft operating water level and discharge pressure of 10.5 psig

Rough Footprint would be one (1) basin at 30 ft wide x 23 ft long x 21 ft SWD.

### **WWW Scope of Supply**

- Design & Engineering for System
- Two (2) – 30 ft wide x 5 ft deep x 18 ft tall internal settling zone made from Polypropylene
- Thirty-six (36) Messner Aeration panels for the reactor
- Two (2) SS 304L Drop pipe with manifold to feed Messner panels
- Two (2) DEMON® Biomass Separation System
- Three (3) submersible pumps (two duty + one shelf spare) rated at 5 HP motor with VFD's on each pump (operated 8-24 hrs per day)
- Three (3) Radar type level control for each DEMON® Tank & EQ Tank
- Three (3) influent feed pumps to the DEMON® reactor each rated for 175 gpm with VFD's on each pump. (operated 12 - 24 hrs per day) (1 duty + 1 standby)
- Three (3) Positive Displacement blowers (270 SCFM each) with VFD's on each blower (30 HP motors) (operated 14 hrs per day at design load) – (2 Duty + 1 Standby)
- Two (2) – 9.0 HP side mounted mixers with VFD's for each mixer (operated 6 hr/day)
- Seed Sludge for start-up of system delivered to the site
- DEMON® Control program with panel with VFD's for blowers, submersible pump and mixers
- Two (2) pH and DO probe with two (2) SC1000 controller
- Two (2) Conductivity probe with two (2) SC200 controller
- Two (2) Air flow insertion meter and six (6) water flow magnetic meters
- Inspection, start up and training services (5 trips / 20 days)
- 3-4 months of off-site / remote monitoring services
- **Estimated Price for above scope of supply: \$1,090,000 USD**

### **Items not included:**

Tankage for EQ tank sized for 2 hours HRT (for systems with dewatering 24 hours per day or 8 – 12 hours for systems with dewatering 8 – 16 hours per day)

DEMON® tank

Unloading, storage, installation of equipment

Electrical connections and interconnecting piping



Proposal  
Brightwater WWTP  
King County, WA  
BIOSTYR®  
Project. No. 5700147914



Submitted to: Matt Winkler  
Brown & Caldwell

Submitted by: Ashley Waples  
Applications Engineer

Date: 1/24/2020

*This document is confidential and may contain proprietary information.  
It is not to be disclosed to a third party without the written consent of Veolia Water Technologies.*

**Veolia Water Technologies, Inc. dba Kruger**  
4001 Weston Parkway  
Cary, NC 27513  
tel. +1 919-677-8310 • fax +1 919-677-0082  
[www.veoliawatertech.com](http://www.veoliawatertech.com)

**Water Technologies**



## Company Introduction

With 160 years of expertise in the areas of water, energy and waste, Veolia applies its capacity for innovation to pursuing human progress and wellbeing, and improving the performance of businesses and regions. To make the switch from a resource consumption rationale to a use-and-recover approach in today's circular economy, Veolia designs and implements solutions aimed at improving access to resources while at the same time protecting and renewing those same resources.

As the world's leading provider of environmental solutions to cities and businesses, we blend our skills in operations, engineering and technology with an unrivaled international network to offer a wide range of service delivery models to our clients. Whether we're reducing our customers' energy consumption to control costs or helping them meet strict water quality standards, we provide performance and reliability guarantees and measure our work by our customers' satisfaction.

We specialize in providing advanced and differentiating technologies that range from biological nutrient removal to mobile surface water treatment. The ACTIFLO® Microsand Ballasted Clarifier, BioCon® Biosolids Dryer, BIOSTYR®/BIOSTYR DUO™ Biological Aerated Filter (BAF) and Hydrotech Discfilter are just a few of our innovative technologies. Based on this expertise, we believe that we have developed the best solution for your application.



10 MGD Tahoe-Truckee SD BIOSTYR - Truckee, CA

## BIOSTYR® Process Overview

The BIOSTYR® systems are up-flow submerged fixed-film processes that biologically treat carbonaceous and nitrogenous wastes (CBOD,  $\text{NH}_4\text{-N}$ ,  $\text{NO}_3\text{-N}$ ) and remove insoluble pollutants (TSS) through the filtering mechanism of the process. A distinguishing feature of these processes is the ability of the submerged media to provide for both biological treatment and filtration in a single step.



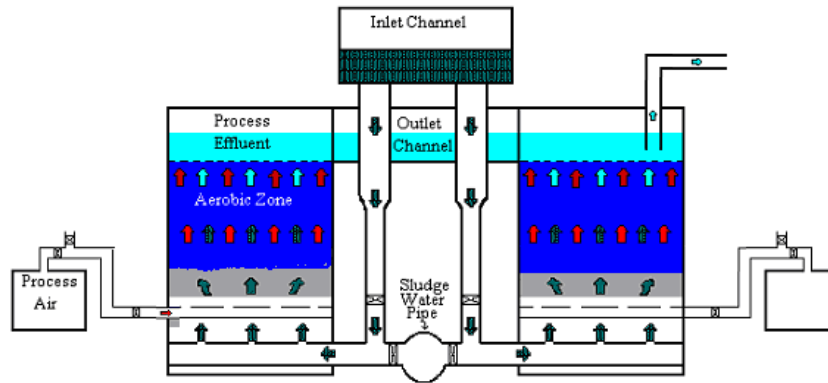

The above figure depicts the general flow path of water through a BIOSTYR® or BIOSTYR® DUO system. Influent wastewater is typically pumped to a common inlet feed channel above the BIOSTYR® cells where it flows down to the individual cells by gravity, although direct pumping to the cells is also common. Within each BIOSTYR® cell, the wastewater flow must be distributed evenly across the bottom of the cell, which is accomplished most commonly by a set of distribution troughs cast into the bottom of the cell.



Interior of BIOSTYR Cell

As wastewater enters a cell, water flows upwards through the filter media, which may vary in depth from 2.0 to 4.2 m depending on the media used and the application. Biological growth on the surface of the media provides treatment of the wastewater as it flows through the cells. Ceiling plates with regularly spaced nozzles are used to retain the filter media. The nozzles allow the treated water to enter a common water reservoir above the filters, which in turn is used to provide water during backwash sequences.

The media contained in the cells is composed of specially manufactured high-density polystyrene beads (BIOSTYRENE) covered by active biomass.

In a system designed for nitrification only, a process air grid is placed below the filter media so that the entire filter bed is aerobic. BOD is oxidized by the biomass in the lower section of the filter. As the wastewater continues up the filter, additional BOD is consumed. When the BOD:TKN ratio falls below a certain limiting level, nitrification occurs, thereby converting the ammonia to nitrate.





Growth of biomass and the retention of suspended solids in the filter media make periodic backwashing necessary. The BIOSTYR® process is designed for a backwash interval of 24 hours or more. The backwash sequence is performed automatically and is triggered either when a preset time limit has expired or when the head loss across the filter exceeds a pre-determined setpoint. Water from the common treated water reservoir flows down through the filter by gravity, thereby expanding the media bed. The air grid located below the media is used to supply scouring air during the backwash sequence. This grid is composed of perforated stainless steel piping that allows air to be injected into the filters.

Like other filtration processes, high TSS and BOD concentrations in the influent waste stream can increase the rate of clogging. If the influent waste stream contains high levels of TSS or BOD, it is desirable to install clarification to partially treat the wastewater.

The BIOSTYR® process provides several significant improvements over other fixed film systems. First, using a floating media bed in conjunction with an up-flow system ensures that the nozzles used to retain the media are only in contact with treated water. This prevents the nozzles from clogging and provides easy access for nozzle maintenance or replacement.

Second, the counter-current backwashing sequence ensures efficient removal of accumulated solids. During backwashing sequences, the downward flow expands the filter media and utilizes gravity to aid in flushing solids from the bottom of the filter. Additionally, the backwash water is supplied from a common reservoir above the filter cells, eliminating the costs associated with backwash pumping. Finally, used backwash water is collected in drainpipes at the bottom of the filters. It is not exposed to the atmosphere, so the potential for odor problems is dramatically reduced.

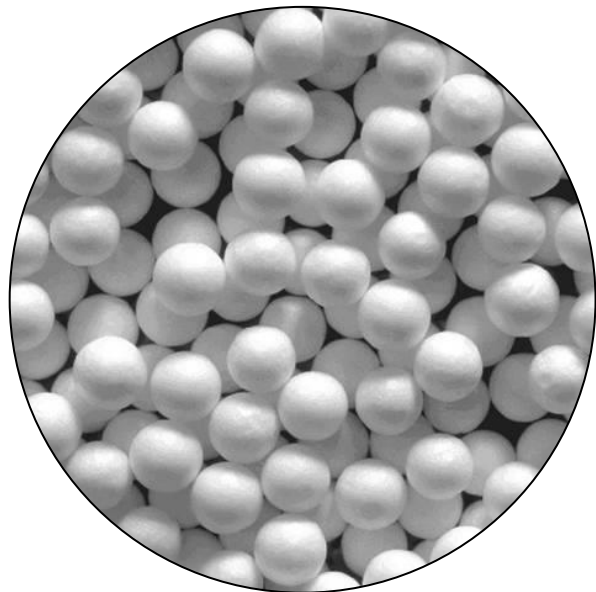

BIOSTYRENE Media



## Design Summary

The design assumes that the influent wastewater is treatable biologically, no toxic compounds are present, sufficient alkalinity is available to maintain appropriate pH values, and that none of the equipment provided would be used in a classified area (e.g. Class 1, Division 1 or Class 1, Division 2) except for methanol feed equipment.

The BIOSTYR® cells do not require dedicated influent screens. Kruger recommends the site have 10 mm fine screening, bar or mesh screens, which could occur upstream of the filters, for instance at the plant headworks. Kruger understands that influent will be fed to the BIOSTYR® system by pumping.

This proposal presents two alternatives for tertiary denitrification with BIOSTYR. The secondary effluent characteristic data and targeted BIOSTYR effluent are summarized in Table 1. The detailed cell information, along with other important process design parameters are also summarized in Table 1.

**Table 1: Design Summary**

Parameters	Alt 2C Brightwater WWTP	Alt 3C Brightwater WWTP
Preceding Process	MLE/MBR Process	MLE/MBR Process
BAF Process	Tertiary Denit. BIOSTYR	Tertiary Denit. BIOSTYR
Controlling Condition	Winter Condition	Winter Condition
BAF Monthly Effluent Limit, NOx-N	10.00	2.00
Max Month (MGD)	40.90	40.90
Peak Flow (MGD)	56.00	56.00
Temperature (degrees C)	13.5	13.5
CBOD (mg/L)	(not available)	(not available)
CBOD (lb/day)	(not available)	(not available)
TSS (mg/L)	(not available)	(not available)
TSS (lb/day)	(not available)	(not available)
NH3-N (mg/L)	(not available)	(not available)
NH3-N Load (lb/day)	(not available)	(not available)
NOx-N (mg/L)	17.1	17.1
NOx-N Load (lb/day)	5,833	5,833



Parameters	Alt 2C Brightwater WWTP	Alt 3C Brightwater WWTP
# Batteries	1	1
Cells / Battery	6	8
# cells	6	8
Cell Area (ft2)	1,268	1,268
	<b>72' x 234'</b>	<b>72' x 294'</b>
<b>Estimated Total Footprint</b>	1 row x 6 cells	1 row x 8 cells
BIOSTYRENE Media Size (mm)	4.5	4.5
Cell Media Bed Depth (ft)	9.00	9.00
Total Area (ft2)	7,609	10,146
Area N-1 Cells (ft2)	6,341	8,877
Total Media V (ft3)	68,483	91,310
Backwash Volume/Cell (ft3)	28,535	28,535
Backwash Return Time (min)	75	75
Peak BW Return Rate (GPM)	2,846	2,846
ProcessAir Demand (SCFM)	Not Applicable	Not Applicable
Backwash Air, Intermittent to 1 Cell at a Time (SCFM)	879	879
Max Month Hyd. Loading (GPM/ft2)	4.11	3.08
Max Month Hyd. Loading (m/hr)	10.04	7.53
Peak Hyd. Loading N-1 (GPM/ft2)	6.58	4.70
Peak Hyd. Loading N-1 (m/hr)	16.09	11.49
Max Month NH3-N load (lb/day/kcf)	Not Applicable	Not Applicable
Max Month NOx-N Removed (lb/day/kcf)	40.3	60.1
Max Month NOx-N Applied (lb/day/kcf)	85.2	63.9
Rough Feed Pumping Energy (kW*hr/yr)	1,397,254	1,397,254
Rough Backwash Pumping Energy (kW*hr/yr)	22,845	30,461
Estimated Backwash Aeration Energy (kW*hr/yr)	7,443	9,924
Estimated Avg. Methanol Consumption (gallons/day)	1,111	2,121



---

## **Scope of Supply**

Kruger is pleased to present our scope of supply which includes process engineering design, equipment procurement, and field services required for the proposed treatment system, as related to the equipment specified. The work will be performed to Kruger's high standards under the direction of a Project Manager. All matters related to the design, installation, or performance of the system shall be communicated through the Kruger representative giving the Engineer and Owner ready access to Kruger's extensive capabilities.

### **Process and Design Engineering**

Kruger provides comprehensive process engineering and design support for our BIOSTYR® system, including but not limited to:

- Detail process design assistance
- Provision of drawings and specifications for use by the consulting engineer in developing the detailed plant design.
- Provision of calculations and other data and attendance at meetings as necessary during state approval processes.
- Shop drawing submittal for Engineer's review and approval. Includes detailed equipment information for all equipment supplied by Kruger.
- Equipment installation instructions for all equipment supplied by Kruger, as well as detailed Operations and Maintenance Manuals.

### **Field Services**

Kruger provides very comprehensive support of our systems throughout the installation and start-up period. Our experienced staff of field service personnel will inspect the installation of each component and assist in mechanical start-up, and will typically include direct manufacturer assistance for key pieces of equipment. Our dedicated team of instrumentation and controls engineers will provide calibration and start-up of all instrumentation and onsite verification of proper functioning of our PLC programming and operator interface systems. Process Engineers will assist in verification of program functions, start-up of the process, any process performance testing and optimization of the process. Kruger personnel will also provide onsite instruction of the operations staff in the proper operation of the Kruger supplied equipment and systems. Together, Kruger's estimate of on-site field service for this project includes:

- A minimum of 60 man-days field support during the construction and start-up of the facility. Included in this period is time for training Owner's staff in the proper operation and maintenance of the BIOSTYR® facility.
- A minimum of 30 man-days field support during performance testing and to provide ongoing process support, supplemental training, and troubleshooting.
- Field support from direct manufacturers for major equipment items purchased and supplied by Kruger, including blowers, pumps, valves, compressors and instruments.



## **BIOSTYR® System Equipment**

Kruger will supply the following equipment associated with the system:

Typical Denitrification Stage Mechanical Equipment Items	Equipment Description
Nozzle Slabs	For all BIOSTYR Cells - 16 slabs/cell. Precast reinforced concrete.
Nozzle Slab Manway	Two (2) per cell.
Nozzles and Gaskets	For all BIOSTYR Cells
Pipe Gallery Manway	One (1) per cell. Stainless Steel.
Site Glasses	One (1) per cell. Stainless Steel. Cast in concrete pipe gallery wall of cells.
Pressure Port Inserts	Two (2) per cell.
Sample Ports	Four (4) Nit cells equipped with 3 ports each. For profile sampling.
Process/Backwash Aeration Grid	One (1) per cell, including inlet header, purge header, lateral distribution lines, couplings, wall brackets, floor stand support structure, and wall inserts. Piping is stainless steel. <u>Anchor bolts provided by Contractor.</u>
Biostyrene Media	Refer to Table 1. <u>Media installation is included. Some Contractor assistance is required.</u>
Backwash Aeration Blowers	1 + 1 Rotary lobe blowers total for each system, 75HP each
Backwash Channel Cover Plates	One (1) set per cell.
Backwash Sludge Pumps	Three (3) backwash pumps per battery. To transfer backwash water from the backwash mud well to primary treatment facility, including necessary check and isolation valves.
Automatic Process Valves	1x Feed valve/cell, 1x Feed isolation/cell, 2x Backwash valve/cell, 1x Air supply/cell, 2x Air supply isolation/cell, 1x Air grid purge/cell, 2x Air grid purge isolation/cell, 1x blower station unload total, 1x backwash header total,
Cell Effluent Slide Gate Assemblies	Four (4) slide gates for each cell. For the effluent ports in each BIOSTYR cell.
Instrument Air System	One (1) common air compressor station for to provide compressed air for pneumatic actuators. System includes backup/duplex compressor, receiving tank, refrigerated air dryer, controller, regulator, and necessary filters.



Typical Denitrification Stage Mechanical Equipment Items	Equipment Description
Spare Parts	10% extra Nozzles, Nozzle Inserts, Gaskets, Fill Ports and Fill Port Inserts are included in Kruger's Scope of supply. 10% Extra media is included in Kruger's scope of supply to compensate for compression of media during shipping and installation.
Denitrification Stage Instrumentation and Controls Equipment Items*	Description
Submersible Pressure Transducer	Liquid Level Measurement. One (1) in each Denit. Effluent channel and backwash tanks, for a total of two (2).
pH/Temperature Probe	One (1) in the influent and effluent streams, for a total of two (2)
DO Probe (LDO)	One (1) in the influent stream, for a total of one (1)
Thermal Mass Flowmeter	One for the common blower station distribution header.
NO <sub>3</sub> -N Analyzer	Two (2) NO <sub>3</sub> -N Analyzers, one for BIOSTYR® Denit Influent and effluent streams. Must be located indoors in a climate controlled environment
Pressure Transmitter	One (1) for each BIOSTYR cell.
PLC Control Cabinet	NEMA 12; ControlLogix PLC; Panelview HMI; 120V Feed

\* All instruments supplied with integral signal converter/transmitter where applicable. Kruger will calibrate and startup Instruments supplied by Kruger. Instruments supplied by others will require calibration and start-up by others.



## **Scope of Supply BY INSTALLER/PURCHASER**

The following items are NOT included in the scope of supply for the system and should be provided for by the Installing Contractor/Purchaser of the system *unless explicitly stated as included in the above scope of supply*. These items include, but are not necessarily limited to, the following items:

- Concrete foundations, pads, tanks, structural components, walkways, handrail, grating and covers,
- Equipment installation, piping to and from the system, interconnecting piping, manual isolation valves or gates, anchor bolts, epoxy/adhesive for anchors,
- Raw influent wastewater pumping, influent screening and grit removal facilities,
- Solids handling/disposal system, WAS pumps, digester equipment,
- Effluent holding tanks/equipment, disinfection equipment, outfalls,
- Chemical addition systems, containment, odor control equipment, laboratory systems or equipment,
- Overhead gantries or cranes,
- Motor control center, motor starters, adjustable frequency drives, main disconnects, breakers, generators, or power supply,
- Field wiring, interconnecting wiring, conduit, wiring terminations at equipment, local equipment disconnects, local equipment control panels, and wiring terminations at control panels,
- All electrical and mechanical hardware with the exception of the equipment that is identified above,
- All work associated with buildings or other structures used for housing any part of the system provided, including HVAC and electrical work.

## **Schedule**

- Shop drawings will be submitted within 6-8 weeks of receipt of an executed contract by all parties.
- All equipment will be delivered within 18-20 weeks after receipt of written approval of the shop drawings.
- Installation manuals will be furnished upon delivery of equipment.
- Operation and Maintenance Manuals will be submitted within 90 days after receipt of approved shop drawings.





---

## Pricing

The price for the BIOSTYR® systems, as defined herein, including process and design engineering, field services, and equipment supply is

**Option 2C: \$6,600,000**

**Option 3C: \$8,100,000**

**Please note that the above pricing is expressly contingent upon the items in this proposal and are subject to Kruger Standard Terms of Sale detailed herein.**

This pricing is FOB shipping point, with freight allowed to the job site. This pricing does not include any sales or use taxes. In addition, pricing is valid for ninety (90) days from the date of issue and is subject to negotiation of a mutually acceptable contract.

### Terms of Payment

The terms of payment are as follows:

- 10% on receipt of fully executed contract
- 15% on submittal of shop drawings
- 75% on the delivery of equipment to the site

Payment shall not be contingent upon receipt of funds by the Contractor from the Owner. There shall be no retention in payments due to Kruger. All other terms per our Standard Terms of Sale are attached.

All payment terms are net 30 days from the date of invoice. Final payment not to exceed 120 days from delivery of equipment.



## Kruger Standard Terms of Sale

1. Applicable Terms. These terms govern the purchase and sale of the equipment and related services, if any (collectively, "Equipment"), referred to in Seller's purchase order, quotation, proposal or acknowledgment, as the case may be ("Seller's Documentation"). Whether these terms are included in an offer or an acceptance by Seller, such offer or acceptance is conditioned on Buyer's assent to these terms. Seller rejects all additional or different terms in any of Buyer's forms or documents.
2. Payment. Buyer shall pay Seller the full purchase price as set forth in Seller's Documentation. Unless Seller's Documentation provides otherwise, freight, storage, insurance and all taxes, duties or other governmental charges relating to the Equipment shall be paid by Buyer. If Seller is required to pay any such charges, Buyer shall immediately reimburse Seller. All payments are due within 30 days after receipt of invoice. Buyer shall be charged the lower of 1 ½% interest per month or the maximum legal rate on all amounts not received by the due date and shall pay all of Seller's reasonable costs (including attorneys' fees) of collecting amounts due but unpaid. All orders are subject to credit approval.
3. Delivery. Delivery of the Equipment shall be in material compliance with the schedule in Seller's Documentation. Unless Seller's Documentation provides otherwise, Delivery terms are F.O.B. Seller's facility.
4. Ownership of Materials. All devices, designs (including drawings, plans and specifications), estimates, prices, notes, electronic data and other documents or information prepared or disclosed by Seller, and all related intellectual property rights, shall remain Seller's property. Seller grants Buyer a non-exclusive, non-transferable license to use any such material solely for Buyer's use of the Equipment. Buyer shall not disclose any such material to third parties without Seller's prior written consent.
5. Changes. Seller shall not implement any changes in the scope of work described in Seller's Documentation unless Buyer and Seller agree in writing to the details of the change and any resulting price, schedule or other contractual modifications. This includes any changes necessitated by a change in applicable law occurring after the effective date of any contract including these terms.
6. Warranty. Subject to the following sentence, Seller warrants to Buyer that the Equipment shall materially conform to the description in Seller's Documentation and shall be free from defects in material and workmanship. The foregoing warranty shall not apply to any Equipment that is specified or otherwise demanded by Buyer and is not manufactured or selected by Seller, as to which (i) Seller hereby assigns to Buyer, to the extent assignable, any warranties made to Seller and (ii) Seller shall have no other liability to Buyer under warranty, tort or any other legal theory. If Buyer gives Seller prompt written notice of breach of this warranty within 18 months from delivery or 1 year from beneficial use, whichever occurs first (the "Warranty Period"), Seller shall, at its sole option and as Buyer's sole remedy, repair or replace the subject parts or refund the purchase price therefore. If Seller determines that any claimed breach is not, in fact, covered by this warranty, Buyer shall pay Seller its then customary charges for any repair or replacement made by Seller. Seller's warranty is conditioned on Buyer's (a) operating and maintaining the Equipment in accordance with Seller's instructions, (b) not making any unauthorized repairs or alterations, and (c) not being in default of any payment obligation to Seller. Seller's warranty does not cover damage caused by chemical action or abrasive material, misuse or improper installation (unless installed by Seller). THE WARRANTIES SET FORTH IN THIS SECTION ARE SELLER'S SOLE AND EXCLUSIVE WARRANTIES AND ARE SUBJECT TO SECTION 10 BELOW. SELLER MAKES NO OTHER WARRANTIES OF ANY KIND, EXPRESS OR IMPLIED, INCLUDING WITHOUT LIMITATION, ANY WARRANTY OF MERCHANTABILITY OR FITNESS FOR PURPOSE.
7. Indemnity. Seller shall indemnify, defend and hold Buyer harmless from any claim, cause of action or liability incurred by Buyer as a result of third party claims for personal injury, death or damage to tangible property, to the extent caused by Seller's negligence. Seller shall have the sole authority to direct the defense of and settle any indemnified claim. Seller's indemnification is conditioned on Buyer (a) promptly, within the Warranty Period, notifying Seller of any claim, and (b) providing reasonable cooperation in the defense of any claim.
8. Force Majeure. Neither Seller nor Buyer shall have any liability for any breach (except for breach of payment obligations) caused by extreme weather or other act of God, strike or other labor shortage or disturbance, fire, accident, war or civil disturbance, delay of carriers, failure of normal sources of supply, act of government or any other cause beyond such party's reasonable control.
9. Cancellation. If Buyer cancels or suspends its order for any reason other than Seller's breach, Buyer shall promptly pay Seller for work performed prior to cancellation or suspension and any other direct costs incurred by Seller as a result of such cancellation or suspension.
10. LIMITATION OF LIABILITY. NOTWITHSTANDING ANYTHING ELSE TO THE CONTRARY, SELLER SHALL NOT BE LIABLE FOR ANY CONSEQUENTIAL, INCIDENTAL, SPECIAL, PUNITIVE OR OTHER INDIRECT DAMAGES, AND SELLER'S TOTAL LIABILITY ARISING AT ANY TIME FROM THE SALE OR USE OF THE EQUIPMENT SHALL NOT EXCEED THE PURCHASE PRICE PAID FOR THE EQUIPMENT. THESE LIMITATIONS APPLY WHETHER THE LIABILITY IS BASED ON CONTRACT, TORT, STRICT LIABILITY OR ANY OTHER THEORY.
11. Miscellaneous. If these terms are issued in connection with a government contract, they shall be deemed to include those federal acquisition regulations that are required by law to be included. These terms, together with any quotation, purchase order or acknowledgment issued or signed by the Seller, comprise the complete and exclusive statement of the agreement between the parties (the "Agreement") and supersede any terms contained in Buyer's documents, unless separately signed by Seller. No part of the Agreement may be changed or cancelled except by a written document signed by Seller and Buyer. No course of dealing or performance, usage of trade or failure to enforce any term shall be used to modify the Agreement. If any of these terms is unenforceable, such term shall be limited only to the extent necessary to make it enforceable, and all other terms shall remain in full force and effect. Buyer may not assign or permit any other transfer of the Agreement without Seller's prior written consent. The Agreement shall be governed by the laws of the State of North Carolina without regard to its conflict of laws provisions.



# 36F Quotation Curve



FAIRBANKS NIJHUIS™

<b>CURVE NUMBER:</b>	C-W190258F	<b>SPEED</b>	705 RPM	<b>DRIVER</b>	250 HP	<b>DIAMETER</b>	AS REQ'D	<b>SPHERE</b>	2.41"	<b>GUARANTEED VALUES</b>													
<b>REV.</b>	0	<b>STAGES</b>	20	<b>IMPELLER</b>	AS REQ'D	<b>DATE</b>	1/6/2020	<b>BY</b>	WSF	<b>FLOW</b>	50	<b>PUMP EFF</b>	79.5	<b>HP</b>	----								
THIS CURVE IS BASED ON THE ACTUAL TEST PERFORMANCE OF A SIMILAR PUMP. ONLY THE INDICATED POINT(S) IS GUARANTEED.										----	----	----	----	----									
										Performance testing will utilize Acceptance Grade 1U per ANSI/HI 14.6.3.4.										----	----	----	----
										----	----	----	----	----									

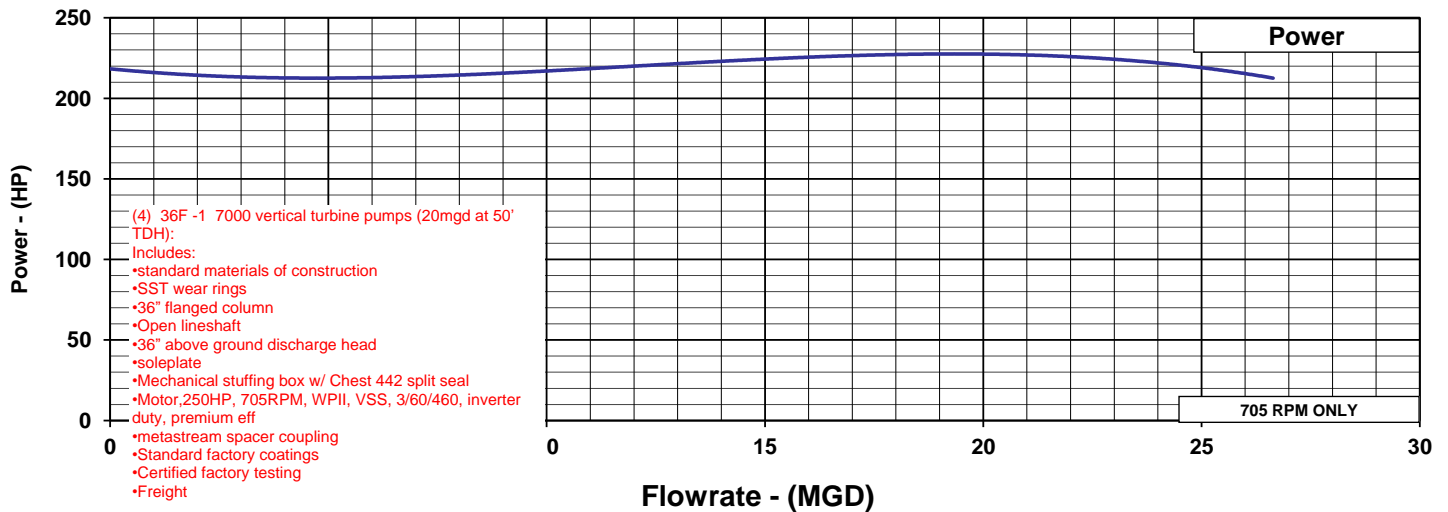
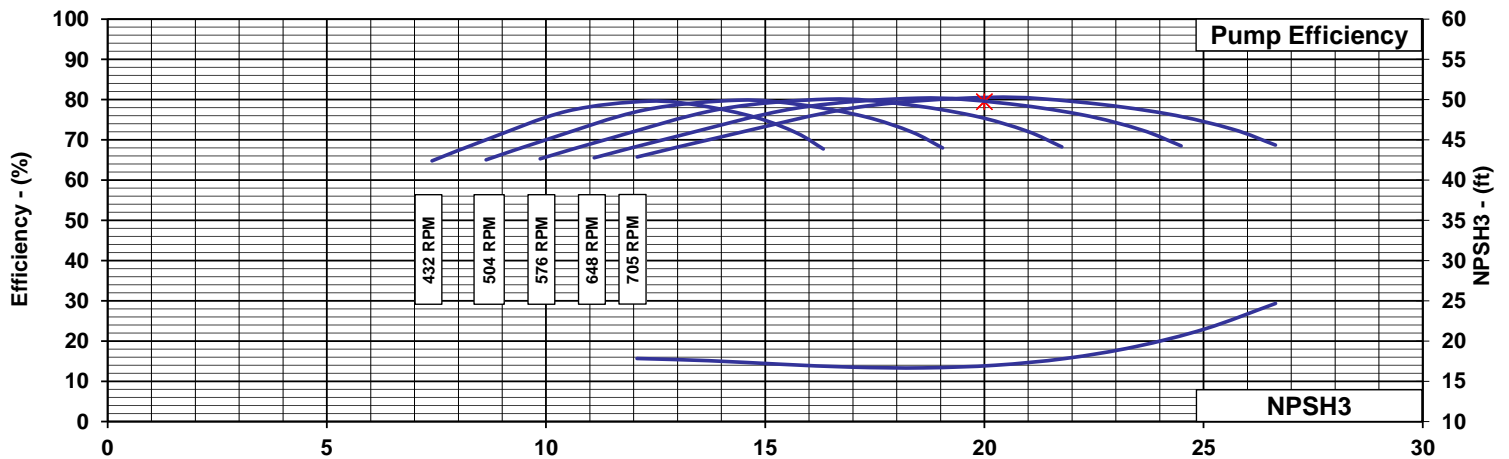
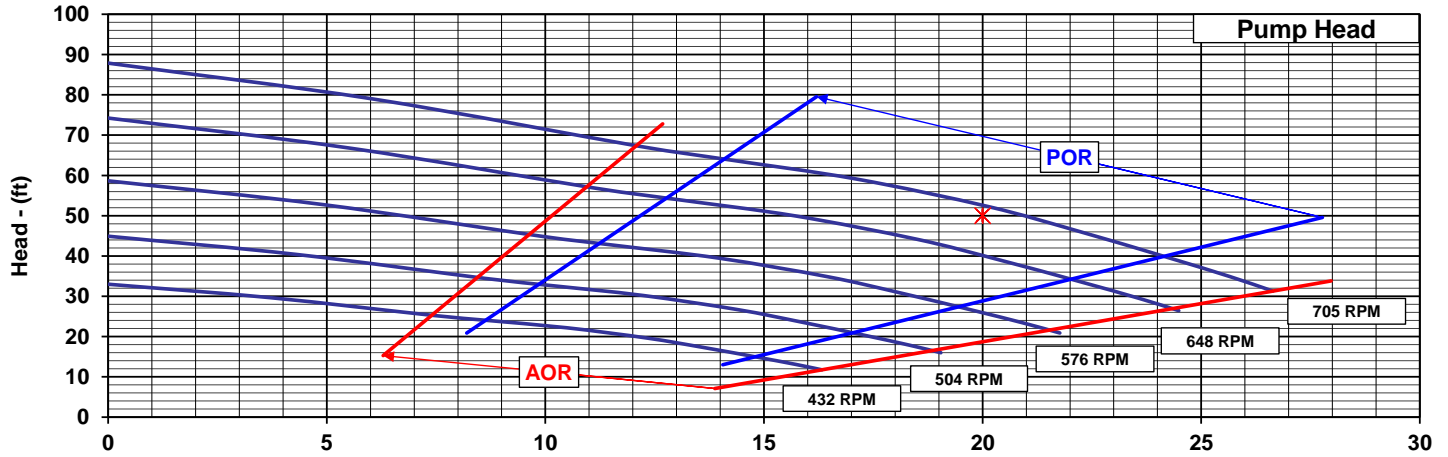

- (4) 36F -1 7000 vertical turbine pumps (20mgd at 50' TDH):
- Includes:
- standard materials of construction
- SST wear rings
- 36" flanged column
- Open lineshaft
- 36" above ground discharge head
- soleplate
- Mechanical stuffing box w/ Chest 442 split seal
- Motor, 250HP, 705RPM, WP11, VSS, 3/60/460, inverter duty, premium eff
- metastream spacer coupling
- Standard factory coatings
- Certified factory testing
- Freight

Not included:

- startup
- spare parts
- taxes

Price: \$205,000.00 Net Each (Budgetary estimate)