

This document is for reference purposes only and is no longer being updated. The information may be out of date and links may not work.  
This document may not meet accessibility standards. If you need to request an accessible version of a resource,  
please reach out to the contact on this page.

# KING COUNTY

# ROAD STANDARDS

## 1987

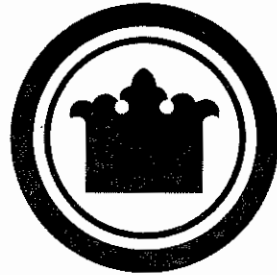

**DONALD J. LABELLE, Director**  
**Department of Public Works**

**LOUIS J. HAFF, P.E.**  
**County Road Engineer**

King County  
Department of Public Works  
May 1987

Compiled and Edited by  
C. STUART MACVEIGH, P.E.  
Road Standards Project Engineer

April 27, 1987  
1341B/MCf:ple

Introduced by: Sullivan/Laing  
Proposed No.: 86-372

ORDINANCE NO. 8041

AN ORDINANCE approving and adopting the "King County Road Standards," 1986 update, as the standards for road design in King County, repealing King County Ordinances 4463 and 5725, and K.C.C. 19.20.010 through 19.20.080.

PREAMBLE:  
The King County road standards were last adopted in their entirety by King County Ordinance 4463 dated August 30, 1979. Twenty pages were added or revised by King County Ordinance 5725, dated October 26, 1981. The proposed new publication "King County Road Standards," 1986 update, provides a badly needed updating of the 1979 document as revised. It corrects serious shortcomings in the road standards for short subdivisions. It also improves traffic safety in critical areas such as sight distance and utility pole location.

BE IT ORDAINED BY THE COUNCIL OF KING COUNTY:

SECTION 1: Repeal. King County Ordinances 4463 and 5725; and K.C.C. 19.20.010 through 19.20.080 are hereby repealed.

SECTION 2. Adoption. A. "King County Road Standards," 1986 update, incorporated herein as Attachment A, including the changes identified in the errata sheets dated December 10, 1986, and December 17, 1986, are hereby approved and adopted as the King County standards for road design and construction.

B. The department of public works is hereby authorized to revise and renumber the drawings in the King County Road Standards, 1986 update to comply with changes verbally described in the errata sheets.

C. The department of public works is hereby authorized to incorporate drawings for catch basins and manholes provided by the Washington State Department of Transportation and the American Public-Works-Association into these standards after the date of adoption of this ordinance.

SECTION 3. Terms. A. "Standards" means King County Roads Standards.

B. "Engineer" means King County road engineer, having authorities specified in RCW 36.75.050 and 36.80, or his authorized representative.

SECTION 4. Applicability. A. The standards may apply to modifications of roadway features or existing facilities which are within the scope of reconstructions or capital improvement projects when so required by King County or to the extent they are expressly referred to in project plans and specifications. These standards are not intended to apply to "resurfacing,

restoration, and rehabilitation" projects as those terms are defined in the Local Agency Guidelines, Washington State Department of Transportation, as amended; however, the engineer may in his discretion consider the standards as optional goals.

B. The standards shall apply to every new placement and every planned nonemergency replacement of existing utility poles and other utility structures within the King County right-of-way.

SECTION 5. Any land development which is required by operation of any county ordinance or adopted standard to improve roads within, abutting, or serving the development shall do so in accordance with these standards.

SECTION 6. References. The standards implement and are intended to be consistent with the references listed in Section 1.04 of Attachment A, "King County Road Standards 1986."

SECTION 7. Variances. Variances from these standards may be granted by the engineer upon evidence that such variances are in the public interest, and that requirements for safety, function, fire protection, appearance, and maintainability based upon sound engineering judgement are fully met. Detailed procedures for requesting variances are contained in administrative rules available from the county road engineer. Variances must be approved prior to construction. Any variances from these

standards which do not meet the Uniform Fire Code will require concurrence by the King County fire marshal.

SECTION 8. Penalties. Failure to comply with these standards may result in denial of plan or development permit approval, revocation of prior approvals, legal action for forfeiture of bond, code enforcement, and/or other penalties as provided by law.

SECTION 9. Severability. If any part of these standards as established by ordinance shall be found invalid, all other parts shall remain in effect.

SECTION 10. This ordinance shall take effect ninety (90) days from its enactment.

SECTION 11. The "Roads Standards" presently codified in K.C.C. 19.20 are hereby transferred to K.C.C. Title 14, Roads and Bridges.

INTRODUCED AND READ for the first time this 4th day of August, 1985.

PASSED this 24th day of April, 1987.  
KING COUNTY COUNCIL  
KING COUNTY, WASHINGTON

*Henry J. Smith*  
Chair

ATTEST:

*Donna M. Quinn*  
Clerk of the Council

APPROVED this 7th day of May, 1987.

*James D. Hill*  
King County Executive

KING COUNTY ROAD STANDARDS 1987

TABLE OF CONTENTS

PURPOSE

CHAPTER 1. GENERAL CONSIDERATIONS

1.01	Shortened Designation	2
1.02	Applicability	2
1.03	Responsibility to Provide On Abutting Roads	2
1.04	General References	3
1.05	Washington State Documents as Primary Design & Construction References	3
1.06	Other Specifications	3
1.07	Road Plans	4
1.08	Variations	4
1.09	Penalties	5
1.10	Meaning of Terms	5
1.11	Severability	6

CHAPTER 2. ROAD TYPES & GEOMETRICS

2.01	Road Classifications	7
2.02	Arterial Roads	9
2.03	Residential Access Streets	10
2.04	Commercial Access Streets	11
2.05	Private Streets	12
2.06	Half Streets	13
2.07	Cul-de-Sacs	13
2.08	Intersections	14
2.09	Maximum Grade	15
2.10	Low Speed Curves	15
2.11	Stopping Sight Distance	15
2.12	Entering Sight Distance	16
2.13	Medians	16
2.14	One-Way Streets	16
2.15	Bus Turns & Turn-Outs	16
2.16	Exception to Paving on Minor Access Streets (Residential)	17
2.17	Expressways	17
2.18	Slope, Wall, & Drainage Easements	17

TABLE OF CONTENTS (Continued)

CHAPTER 3. DRIVEWAYS, WALKS, & TRAILS

3.01	Driveways	18
3.02	Concrete Sidewalks	19
3.03	Concrete for Curbs, Gutters, & Sidewalks	20
3.04	Expansion and Dummy Joints	20
3.05	Curb Ramps	21
3.06	Concrete Steps and Metal Handrail	21
3.07	Asphalt Walkways	21
3.08	Bikeways	22
3.09	Equestrian Lanes	23
3.10	Off-Street Bikeways, Walkways & Equestrian Trails	23

CHAPTER 4. SURFACING

4.01	Residential Streets; Pedestrian, Bike & Equestrian Facilities	24
4.02	Requirements for Residential Streets on Poor Subgrade	26
4.03	Arterials	26
4.04	Materials & Lay-Down Procedures	26
4.05	Pavement Marking	26

CHAPTER 5. ROADSIDE FEATURES

5.01	Rock Facings	27
5.02	Side Slopes	28
5.03	Street Trees & Landscaping	28
5.04	Mail Boxes	29
5.05	Street Illumination	31
5.06	Survey Monuments	31
5.07	Roadway Barricades	31
5.08	Bollards	32
5.09	Guardrail	32
5.10	Off-Street Parking Spaces	32
5.11	Roadside Obstacles	32

TABLE OF CONTENTS (Continued)

CHAPTER 6. BRIDGES

6.01	Principal References . . . . .	33
6.02	Bridge Geometrics . . . . .	33
6.03	Bridge Design Criteria . . . . .	33
6.04	Special Permits . . . . .	34

CHAPTER 7. DRAINAGE

7.01	Drainage Plan . . . . .	35
7.02	Drainage Methods in Shoulder & Ditch Section . . . . .	35
7.03	Storm Sewers and Culverts . . . . .	36
7.04	Drains . . . . .	38
7.05	Filter Fabric for Drains . . . . .	38
7.06	Catch Basins, Manholes & Inlets . . . . .	38
7.07	Frames, Grates, & Covers . . . . .	39
7.08	Other Types and Materials . . . . .	41
7.09	Runoff Control Policies . . . . .	41
7.10	Storm Drainage Trenches . . . . .	42

CHAPTER 8. UTILITIES

8.01	Franchising Policy and Permit Procedure . . . . .	43
8.02	Standard Utility Locations Within the Right of Way . . . . .	43
8.03	Underground Utility Installation . . . . .	45
8.04	Final Utility Adjustment (To Finish Grade) . . . . .	48
8.05	Final Cleanup, Restoration of Surface Drainage, and Erosion Control . . . . .	49

CHAPTER 9. CONSTRUCTION CONTROL & INSPECTION

9.01	Basis for Control of Work . . . . .	50
9.02	Subdivision & Commercial Development Inspection . . . . .	50
9.03	Penalties for Failure to Notify for Development Inspection . . . . .	51
9.04	Embankment Construction Control in Developments . . . . .	51
9.05	Traffic Control in Development Construction . . . . .	53
9.06	County Forces & County Contract Road Inspection . . . . .	53
9.07	Call Before You Dig . . . . .	53

DRAWINGS

<u>NUMBER</u>	<u>SUBJECT</u>	
1	Shoulder Type Roadway . . . . .	54
2	Vertical Curb type Roadway . . . . .	55
3	Rolled Curb Type Roadway . . . . .	56
4	Gravel Surface Roadway . . . . .	57
5	Thickened Edge Roadway . . . . .	58
6	Extruded Curb Roadway . . . . .	59
7	Cul-de-sacs . . . . .	60
8	Curb and Sidewalk Joints . . . . .	61
9	Curb Details . . . . .	62
10	Shoulder & Ditch Section Driveway . . . . .	63
11	Beveled End Pipe Section . . . . .	64
12	Curb & Gutter Section Driveway . . . . .	65
13	Reverse Slope Driveway . . . . .	66
14	Location & Width of New Driveways . . . . .	67
15	Clearance of Roadside Obstacles on Shoulder Type Road . . . . .	68
16	Barricades . . . . .	69
17	Curb Ramps in Vertical Curb . . . . .	70
18	Curb Ramps in Rolled Curb . . . . .	71
19	Rock Facing, Cut Section . . . . .	72
20	Rock Facing, Fill Section . . . . .	73
21	Rock Facing, Under Sidewalk . . . . .	74
22	Concrete Steps and Metal Guardrail . . . . .	75
23	Street Tree Standards . . . . .	76
24	Mailbox Mounting, Curb Type Location . . . . .	77
25	Mailbox Mounting, Shoulder Type Location . . . . .	78
26	Neighborhood Delivery & Collection Box Unit (N.D.C.B.U.) Mailbox Installation . . . . .	79
27	Bollards . . . . .	80
28	Roadway Survey Monument with Case & Cover . . . . .	81
29	Off-road Survey Monument . . . . .	82

DRAWINGS (Continued)

NUMBER	SUBJECT	
30	Field-Tapping of Concrete Pipe	83
31	Catch Basin Type 1	84
32	Catch Basin Type 1-L	85
33	Catch Basin Type 2 - 48", 54", 72", & 96"	86
34	Catch Basin Details	87
35	Manhole Type 1 - 48" & 54"	88
36	Manhole Type 2 - 72" & 96"	89
37	Manhole Type 3 - 48", 54", 72", & 96"	90
38	Manhole Type 4	91
39	Manhole Details	92
40	Curb Inlet	93
41	Standard Grate	94
42	Standard Frame with Vertical Curb Installation	95
43	Solid Cover	96
44	Through-Curb Inlet Frame	97
45	Through-Curb Inlet Frame & Grate with Vertical Curb Installation	98
46	Vaned Grate	99
47	Rolled Curb Frame & Grate	100
48	Rolled Curb Frame & Grate Installation	101
49	Locking Manhole Cover	102
50	Locking Manhole Frame	103
51	Rock-lined Shoulder Ditches & Curbed or Turnpike Shoulders	104
52	Flow Restrictor/Oil Pollution Control Device, Tee Type (FR0P-T)	105
53	FR0P-T Shear Gate Detail	106
54	Flow Restrictor/Oil Pollution Control Device, Baffle Type (FR0P-B)	107

KING COUNTY ROAD STANDARDS 1987

PURPOSE

King County has adopted these road design criteria for a two-fold purpose:

- (1) To set forth specific, consistent road design elements for developers and other private parties constructing or modifying road or right-of-way facilities which require County licenses or permits;
- (2) To establish uniform criteria to guide the County's own construction of new County roads or reconstruction of existing roads.

In adopting these Road Standards, the County has sought to encourage standardization of road design elements where necessary for consistency and to assure so far as practical that motoring, bicycling, equestrian, and pedestrian public safety needs are met. Considerations include safety, convenience, pleasant appearance, proper drainage, and economical maintenance. The Standards also provide requirements for the location and installation of utilities within the right-of-way. The County's permitting and licensing activities require the adoption of specific, identifiable standards to guide private individuals and entities in the administrative process of procuring the necessary County approval. Yet, the County must have needed flexibility to carry out its general duty to provide streets, roads, and highways for the diverse and changing needs of the traveling public. Accordingly, these Standards are not intended to represent the legal standard by which the County's duty to the traveling public is to be measured.

These Standards cannot provide for all situations. They are intended to assist but not to substitute for competent work by design professionals. It is expected that land surveyors, engineers, and architects will bring to each project the best of skills from their respective disciplines. These Standards are also not intended to limit unreasonably any innovative or creative effort which could result in better quality, better cost savings, or both. Any proposed departure from the Standards will be judged, however, on the likelihood that such variance will produce a compensating or comparable result, in every way adequate for the road user and County resident.

CHAPTER 1. GENERAL CONSIDERATIONS

1.01 Shortened Designation: These King County Road Standards will be cited routinely in the text as the "Standards" and on the drawings as "KCRS."

1.02 Applicability: These Standards shall apply prospectively to all newly constructed road and right-of-way facilities, both public and private, within King County except where otherwise provided in King County Code Title 21 in which case the Road Standards shall apply only where specifically cited. In the event of conflict with the current short subdivision code, K.C.C. Chapter 19.26, these Standards shall control.

The Standards may apply to modifications of roadway features of existing facilities which are within the scope of reconstructions or capital improvement projects when so required by King County or to the extent they are expressly referred to in project plans and specifications. These Standards are not intended to apply to "resurfacing, restoration, and rehabilitation" projects as those terms are defined in the Local Agency Guidelines, WSDOT, as amended; however, the Engineer may at his discretion consider the Standards as optional goals.

The Standards shall apply to every new placement and every planned, non-emergency replacement of existing utility poles and other utility structures within the King County right-of-way.

1.03 Responsibility to Provide Roadway Improvements: Any land development which will impact the service level, safety, or operational efficiency of abutting or serving roadways or is required by other County code or ordinance to improve such roadways shall improve those roadways in accordance with these Standards.

1.04 General References: The Standards implement and are intended to be consistent with:

A. Home Rule Charter for King County, approved by the electorate on November 5, 1968; specifically subsection 920.20.10.

B. King County Code, as amended, including:

Title 14, Roads and Bridges  
Title 16, Building and Construction Standards  
Title 17, Fire Code  
Title 19, Subdivisions  
Title 20, Planning  
Title 21, Zoning  
Titles 46 and 47, Traffic

- C. Implementing guidelines on drainage prepared by Surface Water Management Division, King County Department of Public Works, and hereafter referred to as the "Drainage Guidelines."
  - D. King County Comprehensive Plan 1985, as updated.
  - E. King County Transportation Plan, current edition.
  - F. Affordable Housing Policy Plan.
  - G. Adopted Community Plans.
  - H. King County Urban Trails Plan as amended.
  - I. King County General Bicycle Plan, as amended.
  - J. King County Capital Improvement Program, as amended.
  - K. King County Parks and Open Space Plan 1986, when adopted.
  - L. King County Specifications for Off-Street Parking.
- 1.05 WSDOT/APWA Documents as Primary Design and Construction References: Except where these Standards provide otherwise, design detail, construction workmanship, and materials shall be in accordance with the following publications produced separately by Washington State Department of Transportation (WSDOT), or jointly by WSDOT and Washington State Chapter of American Public Works Association (APWA).
- A. WSDOT/APWA Standard Specifications for Road, Bridge, and Municipal Construction, as adopted by King County. These will be referred to as the "WSDOT/APWA Standard Specifications."
  - B. On interim basis, the WSDOT Standard Plans for Road and Bridge Construction, to be referred to as the "WSDOT Standard Plans." Subsequently, when published, the WSDOT/APWA version to be termed herein the "WSDOT/APWA Standard Plans," current edition as amended.
  - C. WSDOT Design Manual, current edition as amended.
  - D. County Design Standards, Washington State Department of Transportation (WSDOT), current edition as amended.
- 1.06 Other Specifications: These include the following, which shall be applicable when pertinent, when specifically cited in the Standards, or when required by state or federal funding authority.

- A. Local Agency Guidelines, WSDOT, as amended.
  - B. Guidelines for Urban Arterial Program, WSDOT, as amended.
  - C. Design criteria of federal agencies including the Federal Housing Administration, Department of Housing and Urban Development; and the Federal Highway Administration, Department of Transportation.
  - D. A Policy on Geometric Design of Highways and Streets, American Association of State Highway and Transportation Officials (AASHTO), current edition.
  - E. Standard Specifications for Highway Bridges, adopted by the American Association of State Highway and Transportation Officials (AASHTO), current edition.
  - F. U. S. Department of Transportation Manual on Uniform Traffic Control Devices, as amended and approved by Washington State Department of Transportation, abbreviated as the "MUTCD."
- 1.07 Road Plans: Plans for roads and road drainage shall be prepared and submitted consistent with these Standards and in accordance with administrative rule published by Director, Department of Public Works. These requirements apply generally to County roads whether constructed by private or public agency. Subject to review, the Engineer may waive plan requirements, wholly or in part, based on the following criteria:
- A. For a private road if:
    - 1. The road is to remain private, and
    - 2. No more than 10,000 square feet will be cleared and graded, and
    - 3. The existing grade or slope in the road right-of-way or easement does not exceed 12%, and
    - 4. The work will not intercept a drainage swale or otherwise impact natural surface drainage as set forth in administrative guidelines published by Department of Public Works and Department of Planning and Community Development.
  - B. For a commercial building permit if:
    - 1. A street is to be constructed, improved or widened by no more than eight feet, and
    - 2. No more than 100 feet of curb and gutter and/or storm sewer is to be added within the right-of-way, and

3. Plans do not include a retention/detention facility within the right-of-way, and
4. The development includes no more than 5,000 square feet of impervious surface.

1.08 Variations: Variations from these Standards may be granted by the Engineer upon evidence that such variations are in the public interest, and that requirements for safety, function, fire protection, appearance, and maintainability based upon sound engineering judgement are fully met. Detailed procedures for requesting variations are contained in an administrative rule available from the County Road Engineer. Variations must be approved prior to construction. Whenever the need for a variation can be identified in advance, the variation should be proposed at preliminary plat stage and included for consideration during plan review and public hearing. Any variations from these Standards which do not meet the Uniform Fire Code will require concurrence by the King County Fire Marshal.

1.09 Penalties: Failure to comply with these Standards may result in denial of plan or development permit approval, revocation of prior approvals, legal action for forfeiture of bond, code enforcement, and/or other penalties as provided by law.

1.10 Meaning of Terms:

"Cul-de-sac": Short street having one end open to traffic and the other temporarily or permanently terminated by a vehicle turnaround.

"Developer": Any person, firm, partnership, association, joint venture or corporation or any other entity who undertakes to subdivide for the purpose of resale and profit.

"Engineer": King County Road Engineer, having authorities specified in RCW 36.75.050 and 36.80, or his authorized representative.

"Half-Street": Street constructed along edge of development, utilizing half the regular width of right-of-way and permitted as an interim facility pending construction of the other half of the street by the adjacent owner.

"Loop": Road of limited length forming a loop, having no other intersecting road, and functioning mainly as direct access to abutting properties. A Loop may be designated for one-way or two-way traffic.

"Private Street": Private vehicular access provided for by an access tract, easement, or other legal means, serving two or more potential dwelling units; privately owned and maintained.

"Public Street": Publicly owned and maintained street.

"Right-of-Way": Land, property, or property interest (e.g., an easement), usually in a strip, acquired for or devoted to transportation purposes.

"Road" and "Street" will be considered interchangeable terms for the purpose of these Standards.

"Resource Lands": Areas so designated in King County Comprehensive Plan and as implemented through community plans and area zoning; characterized by long-term agriculture, forestry, and mining.

"Resource Lands": Areas so designated in King County Comprehensive Plan and as implemented through community plans and area zoning; characterized by long-term agriculture, forestry, and mining.

"Rural Areas": Areas so designated in King County Comprehensive Plan, and as implemented through community plans and area zoning; characterized by long-term low density of development.

"Transitional Areas": Areas so designated in the King County Comprehensive Plan; characterized by low density but earmarked for redesignation through community planning as either a rural or an urban area.

"Traveled Way": The part of the road made for vehicle travel excluding shoulders and auxiliary lanes.

"Urban Areas": Areas so designated in King County Comprehensive Plan, and as implemented through community plans and area zoning; characterized by denser commercial/industrial and residential development.

"Utility": A company providing public service such as gas, electric power, telephone, telegraph, water, sewer, or cable television, whether or not such company is privately owned or owned by a governmental entity.

1.11 Severability: If any part of these King County Road Standards as established by ordinance shall be found ~~invalid~~, all other parts shall remain in effect.

## CHAPTER 2. ROAD TYPES & GEOMETRICS

### 2.01 Road Classifications.

- A. County roads are classified functionally as indicated in subsections 2.02, 2.03, and 2.04. Function is the controlling element for classification and shall govern right-of-way, road width, and road geometrics. Other given elements such as access, arterial spacing, and average daily traffic count, or ADT, are typical.
- B. Within each functional classification, roads are further characterized as "curb" or "shoulder" type. A "curb" type road typically requires curb and gutter with inlets and underground pipe drainage. A "shoulder" type road typically requires a shoulder and open ditch drainage.
  1. The curb type road is generally required with denser development characteristic of Urban Areas, including residential, institutional, commercial, and industrial development. The shoulder type is generally appropriate for the lower densities of Rural Areas. Actual determination of road type, however, will be made by the Engineer in each case. The needs of particular kinds of development such as low density and clustered housing will be examined. The proposed as development density of the site, together with its potential for further development as designated by an adopted plan, will be used to determine the applicable standard.
  2. In general, roads in a Transitional Area may be constructed to serve the immediate, short-range plans for development in the area. However, right-of-way and alignment shall be provided for the potential higher road classification. Where practicable construction elements such as later grading and the location of drainage and utilities should be done in a way not to preclude later improvement to the higher standard.
  3. Certain exceptions to the shoulder type standard may apply within clustered housing developments and Rural Activity Centers (unincorporated rural towns such as Vashon or Fall City), where urban densities and uses may make a curb type road appropriate. Within these developments, the specifically authorized land uses, adopted community plans, or business district design guidelines may provide for either a curb or a shoulder type road section.
  4. Guidelines applicable to Rural Areas should apply also to Resource Lands.
- C. Terrain classification is a basis for further breakdown of geometric requirements.
  1. Flat terrain is that condition where road sight distances, as governed by both horizontal and vertical restrictions, are generally long or could be made to be so without construction difficulty or major expense.

2. Rolling terrain is that condition where the natural slopes consistently rise above and fall below the road grade line and where occasional steep slopes offer some restriction to normal road horizontal and vertical alignment.

3. Mountainous terrain is that condition where longitudinal and transverse changes in the elevation of the ground with respect to a road are abrupt and where the roadbed is obtained by frequent benching or side hill excavation.

Terrain classification pertains to the general character of the specific route corridor. Roads in valleys or passes of mountainous areas that have all the characteristics of roads traversing flat or rolling terrain should be classified as flat or rolling. In general, rolling terrain conditions cause trucks to reduce to speeds below those of passenger cars on some sections of highway and mountainous terrain causes some truck operation at crawl speeds.



2.03 RESIDENTIAL ACCESS STREETS! Serving Single-Family Dev., see Drawings No. 1-6. For Multiple-Dwelling Dev., see Sec. 2.04, Commercial Access Streets.

CLASSIFICATION FUNCTION	NEIGHBORHOOD COLLECTORS		SUBCOLLECTORS		SUBACCESS STREETS		MINOR ACCESS STREETS (RESIDENTIAL)	
	Streets connecting two or more neighborhoods & connecting to arterials.	URBAN	Streets providing circulation within neighborhoods & connecting to neighborhood collectors.	URBAN	Permanent cul-de-sacs, short through streets, or loops <sup>2</sup> , connecting to subcollectors & not supportive of through traffic.	Typically public streets	Permanent cul-de-sacs or loops <sup>2</sup> with low traffic, providing circulation & access to off-street parking within residential development boundaries.	Public or private streets.
Neighborhood Collector Spacing	RURAL	Under 0.5 Mi.	RURAL	Under 0.5 Mi.	RURAL	35 Maximum	RURAL	16 Maximum
Public or Private St.	Public streets	Public streets	Public streets	Public streets	Public streets	Public streets	Public or private streets.	Public or private streets.
Access	Restricted. Lots front on Loc Access St. where feasible.	As needed with some restrictions.	As needed with some restrictions.	As needed with some restrictions.	As needed with only minimal restrictions.	As needed with only minimal restrictions.	As needed with only minimal restrictions.	As needed with only minimal restrictions.
LAND USE AREA	RURAL	URBAN	RURAL	URBAN	RURAL	URBAN	RURAL	URBAN
Serving Potential No. of Single-Family Dwell. Units.	Over 50	Over 50	25-100	20-100	35 Maximum	35 Maximum	16 Maximum	16 Maximum
CRITERIA	Shoulder	Curb	Shoulder	Curb	Shoulder	Curb	Shoulder	Curb
A. Typical Road Type	Flat	35	30	30	Low Speed Curv	Low Speed Curv	Low Speed Curv.	Low Speed Curv
B. Design Speed <sup>3</sup> (MPH)	Rolling	35	30	30	See Sec. 2.10	See Sec. 2.10	See Sec. 2.10	See Sec. 2.10
	Mountainous	25	25	25	See Sec. 2.10	See Sec. 2.10	See Sec. 2.10	See Sec. 2.10
C. Max. Super-elevation (Ft.-Ft.)	.06	.06	.06	.06	Low Speed Curv	Low Speed Curv	Low Speed Curv	Low Speed Curv
D. Horizontal Curvature <sup>3</sup>	Flat	380	273	273	See Sec. 2.10	See Sec. 2.10	See Sec. 2.10	See Sec. 2.10
	Rolling	380	185	185				
	Mountainous	185	185	185				
E. Max. Grade <sup>4</sup>	Flat	6	7	8	12	12	12	12
	Rolling	8	10	12	15.4	15.4	15.4	15.4
	Mountainous	11	12	12	15.4	15.4	15.4	15.4
F. Standard Stopping Sight Dist. <sup>5</sup> (Ft.)	Flat	250	250	200	150	150	125	125
	Rolling	250	250	200	150	150	125	125
	Mountainous	150	150	150	150	150	125	125
G. Standard Entering Sight Dist. <sup>6</sup> (Ft.)	Flat	490	490					
	Rolling	490	490					
	Mountainous	365	365					
H. Min. Pavement Width (Ft.)	22	36	22	28	20	24.6	20.10	22.8
I. Min. Roadway Width (Ft.)	38	36	38	28	28	24.8	28	22.8
J. Min. Right of Way Width (Ft.)	60	56	60	48	48.9	48.9	48.9	40.5
K. Type of Curb or Shoulder <sup>7</sup>	8" Shoulder	Vertical Curb & Gutter	8" Shoulder <sup>11</sup> & Ditch	Vert. or Rolled Curb & Gutter	4" Shoulder <sup>11</sup> & Ditch	Vert. or Rolled Curb & Gutter	4" Shoulder <sup>11</sup> & Ditch	Vert. or Rolled Curb & Gutter
L. Min. Half St. Paved Wid. (Ft.)	19 1/2	20	19 1/2	20	19 1/2	20	19 1/2	20
M. Min. One-Way Paved Wid. (Ft.)	20	20	20	20	20	20	20	20

N. NOTES:

- 1 Within the above parameters, geometric design for specific streets shall be consistent with MSDOT Design Manual.
- 2 One-way loops: See Section 2.14.
- 3 Design speed is a basis for determining geometric elements and does not imply posted or legally permissible speed. Curves shall be super-elevated within parameters of B, C, and D above.
- 4 Maximum grade may be exceeded for short distances subject to approval by the Engineer. (See Section 2.09.)
- 5 Standard Stopping Sight Distance (SSD) shall apply unless otherwise approved by the Engineer. See Sec. 2.11.
- 6 Standard Entering Sight Distance (ESD) shall apply at intersections and driveways on neighborhood collector's unless otherwise approved by the Eng. See Sec. 2.12.
- 7 For guardrail installations, shoulders shall be 2 feet wider.
- 8 When paved width is less than 28 feet, two additional (four total) off-street parking spaces shall be provided for each single-family unit served.
- 9 Right-of-way (or easement) may be reduced to minimum roadway width provided that sidewalks, utilities, and necessary drainage are otherwise accommodated on permanent easements within the development.
- 10 Exception to paving requirement on minor access shoulder type streets: See Section 2.16.
- 11 As altern. to shldr. and ditch on local access str., underground pipe drng. with either Thickened Edge, Dwg. 5, or Extruded Curb, Dwg. 6, is acceptable.
- 12 Nineteen-foot half street is acceptable provided at least one extra foot of graded, trafficable width is provided on one side.

2.04 COMMERCIAL ACCESS STREETS<sup>1</sup> See Drawings No. 1 and 2.

CLASSIFICATION FUNCTION	MULTIPLE-DWELLING ACCESS STREETS	BUSINESS ACCESS STREETS	INDUSTRIAL ACCESS STREETS	MINOR ACCESS STREETS (COMMERCIAL)
Public or Private Streets	Typically public streets serving all RD and RM zones except RM 900.	Typically public streets serving RM 900 and all B (business) zones.	Typically public streets serving CG and all M Zones.	Local streets providing circulation and access to parking and loading sites within multi dwelling, business, & industrial development boundaries. Public or private streets. See Sec. 2.05.
Access	As needed, with some regulation.	As needed, with some regulation.	As needed with some regulation	As needed with only minimal restrictions.
LAND USE AREA	RURAL	RURAL	RURAL	RURAL
CRITERIA	URBAN	URBAN	URBAN	URBAN
A. Typical Road Type	Shoulder	Shoulder	Shoulder	Shoulder
B. Design Speed <sup>2</sup> (MPH)	35 30 25	35 30 25	35 30 25	Low Speed See Sec. 2.10
C. Max. Super-elevation (Ft./Ft.)	.06	.06	.06	Low Speed Curv See Sec. 2.10
D. Horizontal Curvature <sup>3</sup> : Min. Radius (Ft.)	380 273 185	380 273 185	380 273 185	Low Speed Curv See Sec. 2.10
E. Maximum Grade (%)	7 10 12	7 10 12	6 8 11	7 10 12
F. Standard Stop-ping Sight Dist. (Ft.)	250 200 150	250 200 150	250 200 150	125 125 125
G. Standard Entering Sight Dist. (Ft.)	490 430 365	490 430 365	490 430 365	20 20 20
H. Min. Pavement Width (Ft.)	22	24	24	287 227
I. Min. Roadway Width (Ft.)	38	40	40	487 407
J. Min. Right-of-Way Width (Ft.)	60	60	60	47 407
K. Type of Curb or Shoulder & Ditch	8" Shldr & Ditch	8" Shldr & Ditch	8" Shldr & Ditch	4" Shldr & Ditch
L. Min. Half St. Paved Wid. (Ft.)	19	19	19	20
M. Min. One-Way Paved Wid. (Ft.)	20	22	24	20

N. NOTES:

- 1 "Commercial Access Streets" serve multiple-dwelling, business, and industrial developments. Within the above parameters, geometric design requirements shall be determined for specific streets consistent with the WSDOT Design Manual.
- 2 Design speed is a basis for determining geometric elements and does not imply posted or legally permissible speed. Curves shall be super-elevated within parameters of B, C, and D above.
- 3 Maximum grade may be exceeded for short distances subject to approval by the Engineer. See Sec. 2.09.
- 4 Standard Stopping Sight Distance (SSD) shall apply unless otherwise approved by the Engineer. See Section 2.11.
- 5 Standard Entering Sight Distance (ESD) shall apply at intersections and driveways except on minor access streets unless otherwise approved by the Engineer. See Section 2.12.
- 6 For guardrail installations, shoulders shall be 2 feet wider.
- 7 Right-of-way (or easement) may be reduced to minimum roadway width provided that sidewalks, utilities, and necessary drainage are otherwise accommodated within permanent easements throughout the development.
- 8 Nineteen-foot half street is acceptable provided at least one extra foot of graded, trafficable width is provided on one side.

2.05 Private Streets.

- A. While community street requirements are usually best served by public streets, owned and maintained by the County, private streets may be appropriate for some Local Access streets. Usually these are minor access streets, either residential or commercial.
- B. Private streets may be approved only when they are:
  1. Permanently established by tract or easement providing legal access to each affected lot, dwelling unit, or business and sufficient to accommodate required improvements, to include provision for future use by adjacent property owners when applicable, and
  2. Built to King County road standards, as set forth herein, or secured under the provisions of K.C.C. 19.24.040, and
  3. Accessible at all times for emergency and public service vehicle use, and
  4. Not obstructing, or part of, the present or future public neighborhood circulation plan developed in processes such as the King County Comprehensive Plan, applicable community plan, or Capital Improvement Program, and
  5. Will not result in land locking of present or future parcels, and
  6. Are not needed as public roads to meet the minimum road spacing requirements of these Standards, and
  7. Designed to serve a maximum potential of 16 single-family dwelling units when the entire length of the private road system to the nearest public road is considered. The maximum potential is the number of dwelling units that can possibly be served by the road when physical barriers, zoning or other legal constraints are considered, and
  8. Maintained by a capable and legally responsible owner or homeowners' association or other legal entity made up of all benefited property owners, under the provisions of K.C.C. 19.24.050, and
  9. Clearly described on the face of the plat, short plat, or other development authorization and clearly signed at street location as a private street, for the maintenance of which King County is not responsible.
- C. King County will not accept private streets for maintenance for public roads as public streets until such streets are brought into conformance with current County road standards. This requirement will include the hard surface paving of any streets surfaced originally with gravel.

D. King County will not accept private streets within short plats when the roads providing access to the plat are private and already have the potential to serve more than the number of lots specified in Section 2.05 B.7. Short plats proposed on properties to which the access is over private streets that do not meet the standards in this section shall be denied.

2.06 Half Streets. A half street is an otherwise acceptable roadway section modified to conform to limited right-of-way on the boundary of property subject to development.

A. A half street may be permitted subject to approval by the Engineer when:

1. Such street shall not serve as primary access to more than 30 potential dwelling units.
  2. Such alignment is consistent with or will establish a reasonable circulation pattern, and
  3. There is reasonable assurance of obtaining the prescribed additional right-of-way from the adjoining property with topography suitable for completion of a full-section roadway.
- B. A half street shall meet the following requirements:
1. Right-of-way width of the half street shall equal at least thirty feet, and
  2. Half street shall be graded consistent with locating centerline of the ultimate roadway section on the property line, and
  3. Traveled way shall be surfaced the same as the designated road type to a width not less than 20 feet except that a 19-foot paved width is acceptable in a shoulder type street if at least one extra foot of graded, trafficable width is provided on one edge of street, and
  4. Property line edge of street shall be finished with temporary curbing, shoulders, ditches, and/or side slopes so as to assure proper drainage, bank stability, and traffic safety, and
  5. Half streets shall not intersect other half streets unless so approved by the Engineer.
- C. When a half street is eventually completed to a whole street, the completing builder shall reconstruct the original half street as necessary to produce a proper full-width street of designated section. Centerline shall coincide with property line unless otherwise approved by the Engineer.
- D. The obtaining of any right-of-way or easements needed to accomplish the above shall be the responsibility of the owning builder or developer.

2.07 Cul-de-sacs. See Drawing No. 7.

A. Whenever a cul-de-sac serves more than two lots and extends more than 150 feet from centerline of accessing street to farthest extent of surfaced traveled way a widened "bulb" shall be constructed as follows:

1. Minimum right-of-way diameter across bulb section: 100 feet in a permanent cul-de-sac; 84 feet in a temporary cul-de-sac, with bulb area lying outside straight-street right-of-way provided as temporary easement pending forward extension of the street.
2. Minimum diameter of surfacing across bulb: 80 feet of paving in curb type road; 80 feet total in shoulder type road to include 64 feet of paving and 8-foot shoulders with compacted crushed surfacing material.
3. Cul-de-sac Island: Optional feature for any cul-de-sac when paved diameter is 80 feet or less; mandatory when paved diameter exceeds 80 feet. If provided, island shall have concrete extruded or full-depth vertical curb. There shall be at least 22 feet of paved traveled way in a shoulder type section, and 30 feet of paved traveled way in a curb type section around the circumference. Island shall be grassed or landscaped. It shall be maintained by the adjoining lot owners.
- B. A permanent cul-de-sac shall not be longer than 600 feet measured from centerline of intersecting street to the center of the bulb section. Proposed exceptions to this rule will be considered by the Engineer based on pertinent traffic planning factors.
- C. The Engineer may require an off-street walk or an emergency vehicle access to connect a cul-de-sac at its terminus with other streets, parks, schools, bus stops, or other pedestrian traffic generators, if the Engineer determines that a need exists.

2.08. Intersections.

- A. Angle of Intersection Minimum 85° to 95° Maximum
- B. Minimum Centerline Radius (2-Lane) 55 Feet
- C. Minimum Curb Radius 35 Feet
- D. Minimum Property Line Radius 25 Feet
- E. Spacing between adjacent intersecting streets, whether crossing or T-connecting, should be as follows:

When highest classification involved is:	Minimum centerline offset should be:
Principal Arterial	1,000 Feet
Minor Arterial	500 Feet
Collector Arterial	300 Feet
Any lesser street classification including Low Speed Curves	150 Feet

- F. On sloping approaches at an intersection, landings shall be provided with grade not to exceed one foot difference in elevation for a distance of 30 feet approaching an arterial or 20 feet approaching a residential or commercial street, measured from nearest right-of-way line (extended) of intersecting street.

G. Entering Sight Distance. See Sections 2.02, 2.03, 2.04 and 2.12.

2.09 Maximum Grade.

Maximum grade as shown in Sections 2.02, 2.03, and 2.04 may be exceeded for short distances subject to approval by the Engineer upon showing that no practical alternative exists. Exceptions which exceed 15% will require verification by the Fire Marshal that fire protection requirements will be met. Grades exceeding 12% shall be paved with asphalt concrete (AC) or portland cement concrete (PCC). Any grade over 20% must be portland cement concrete.

2.10 Low Speed Curves, applicable to subaccess and minor access streets only.

	<u>Up to 75°</u>	<u>75° &amp; Over</u>
A. Minimum Centerline Radius (2-lane)	100'	55'
B. Minimum Curb Radius	80'	35'
C. Minimum Property Line Radius	70'	25'

2.11 Stopping Sight Distance (SSD) applies to street classifications as shown in Sections 2.02, 2.03 and 2.04.

- A. Height of eye is 3.5' and height of object is 0.5'.
- B. Standard (or minimum) stopping sight distances (SSD) as provided in Sections 2.02, 2.03, and 2.04 above shall be increased (in feet) in accordance with the following on any downgrade of 3% or steeper:

<u>DESIGN SPEED (MPH)</u>	<u>3%</u>	<u>6%</u>	<u>9%</u>
60	50	110	
50	30	70	70
40	20	40	30
30	10	20	20
20	0	10	20

- C. In difficult topography the Engineer may authorize a reduction in the SSD based on factors mitigating the hazard. Such factors may include an anticipated posted or average running speed less than the design speed.

2.12 Entering Sight Distance (ESD)

Entering Sight Distance applies on driveways and on streets approaching intersections as set forth in Sections 2.02, 2.03, and 2.04. Entering sight distance criteria will not apply on local access streets or minor access streets (commercial).

A. Entering vehicle eye height is 3.5', measured from 10' back from edge of travelled way. Approaching vehicle height is 4.25'.

B. Figures in Sections 2.02, 2.03, and 2.04 apply to an intersection or driveway approach to a typical road under average conditions. In difficult topography the Engineer may authorize a reduction in the ESD based on factors mitigating the hazard. Such factors may include an anticipated posted or average running speed less than the design speed or the provision of acceleration lanes and/or a median space allowing an intermediate stop by an approaching vehicle making a left turn.

C. Where a significant number of trucks will be using the approach road, the Engineer may increase the entering sight distance by up to 30% for single-unit trucks and 70% for semi-trailer combinations.

#### 2.13 Medians.

Optional design feature. Median width shall be additional to, not part of, the specified width of travelled way. Edges shall be similar to outer road edges: either extruded or formed vertical curb; or shoulder and ditch; except that median shoulders shall be minimum four feet in width. Median may be grassed, landscaped, or surfaced with aggregate or pavement. Median shall be designed so as not to limit turning radii or sight distance at intersections.

#### 2.14 One-Way Streets.

Local access streets, including loops, may be designated one-way upon a finding by the Engineer that topography or other site features make two-way traffic impractical.

#### 2.15 Bus Turns and Turn-outs.

For construction on bus routes, designer shall contact Metro, phone 447-6319, to ascertain specific geometric needs of bus operation. Surfacing requirements may also be affected, particularly on shoulders. See Section 4.10B. Metro's publication, "Metro Transportation Facility Design Guidelines," is applicable.

#### 2.16 Exception to Paving on Rural Minor Access Streets (Residential).

A. A Rural minor access street (residential) as described in Section 2.05 and which is a private street shall meet the following standard: It shall be graded and, as minimum treatment, be surfaced full width including shoulders (28 feet) with crushed surfacing material as provided in Section 4.01A Alternative V and Drawing No. 4. Half streets shall be surfaced 20 feet wide or, alternatively, 19 feet wide if at least one-foot of graded, trafficable width is provided on one side. Where con-

necting to a public street the connecting area shall be paved between traveled way and right-of-way line (extended) of the public street, with 35-foot radii. Paving shall be in accordance with Section 4.01A with applicable alternative other than Alternative V.

B. Any Rural minor access street (residential) approved under subsection A above shall remain a private street unless it is upgraded to public street standards at the expense of the subdivider or adjoining lot owners, to include hard surface paving, and accepted by the Engineer for public ownership and maintenance.

2.17 Expressways are higher classification roads which are usually a state or federal responsibility. In the event that the County has jurisdiction over the construction or improvement of such a facility, the work shall be done in accordance with appropriate state or federal standards.

2.18 Slope, Wall, & Drainage Easements. Either the functional classification or particular design features of a road may necessitate slope, wall or drainage easements beyond the right-of-way line. Such easements may be required by the Engineer in conjunction with dedication or acquisition of right-of-way.

3.01 Driveways

SEE PAGE 2  
"SURFACING  
WATERIALS"

CHAPTER 3. DRIVEWAYS, WALKS, & TRAILS

A. Permissible dimensions, slope, and detail shall be as indicated in Drawings No. 10, 11, 12, and 13 and as further specified in the following subsections.

B. Conditions for Approval of New Driveways:

1. Driveways directly giving access onto arterials may be denied if alternate access is available.

2. All abandoned driveway areas on the same frontage shall be removed and the curbing and sidewalk, or shoulder and ditch section, shall be properly restored.

3. Maintenance of driveway approaches shall be the responsibility of the owner whose property they serve.

4. For a commercial establishment on a shoulder and ditch type road, where development of adjoining lands and highway traffic assume urban characteristics as determined by the Engineer, the frontage shall be finished with curb, gutter, and sidewalk, with pipe drainage, all in accordance with these Standards. Alternatively, the Engineer may require the entire frontage area to be graded and paved to the property line with asphalt or portland cement concrete. In such case, surface drainage shall be intercepted and carried in a closed system as set forth in Chapter 7. Access shall be limited by means of a 6-inch curbing. See Extruded Asphalt or Cement Concrete Curb detail, Drawing No. 9.

5. For driveways crossing an open ditch section, culverts shall be 12 inches in diameter or larger if so required to carry anticipated stormwater flows. The property owner making the installation shall be responsible for determining proper pipe size. The Engineer may require the owner to verify the adequacy of pipe size.

C. Location and Width of New Driveways. Refer to Drawing No. 14.

1. A residential driveway is one that normally serves one parcel. Except as provided in Section 3.01 C3a and 3b below, a driveway serving more than one parcel shall be classed as a commercial driveway or a private street.

2. On frontage 75' or less, no more than one driveway per lot shall be constructed; on frontages over 75', two or more driveways per lot may be permitted, subject to approval by the Engineer.

3. No portion of driveway width shall be allowed within 5' of property lines in residential areas or 9' in commercial areas except as follows:

- a. Joint-use driveways serving two adjacent parcels may be built on their common boundary upon formal written agreement by both property owners and approval of the Engineer. Agreement shall be a recorded easement for both parcels of land specifying joint usage.
- b. Driveways may utilize full width of narrow "pipe-stem" if this provides the only access to the lot being served.
- 4. Grade breaks, including the tie to the roadway, shall be constructed as smooth vertical curves. The maximum change in driveway grade shall be 8% within any 10 feet of distance on a crest and 12% within any 10 feet of distance in a sag vertical curve. Driveway shall be graded so as to match into possible future widened road section without encroachment into graded shoulder or sidewalk.
- 5. Driveways in rolled curb sections may be constructed abutting and flush with sidewalk or back of curb without gapping or lowering height of curb.
- D. Existing driveways may be reconstructed as they exist provided such reconstruction is compatible with the reconstructed road.
- E. For commercial or industrial driveways with heavy volume, large vehicle traffic, the Engineer may approve construction as road intersections. Such approval will depend upon traffic engineering analysis.
- F. Notwithstanding any other provisions, driveways will not be allowed where they are prohibited by separate County Council action or where they are determined by the Engineer to create a hazard or impede the operation of traffic on the roadway.

3.02 Concrete Sidewalks:

- A. Shall be required on urban category, curb and gutter type streets as follows:
  - 1. On all arterials, neighborhood collectors, subcollectors, multiple-dwelling and business access streets, both sides.
  - 2. On subaccess streets and industrial access streets, one side.
  - 3. On minor access streets (commercial), one side unless alternative off-street routes are provided for pedestrians and bicycles.
  - 4. On minor access street cul-de-sacs having off-street walkways extending from their termini to other streets, parks, schools, bus stops, or other pedestrian traffic generators, one side. The extended off-street walkway may be required by the Engineer if he determines that the need exists.

B. Shall be constructed:

1. Next to the curb unless planting strips are approved by the Engineer as part of a landscaping plan.
2. At least five feet wide in residential areas. This means five feet clear of mailboxes or other obstructions, except where approved as variance. Width shall be minimum 6.5 feet if curb is next to traveled lane (but not necessary next to parking or bike lanes). The additional width, 1.5 feet or more, may be finished to match the sidewalk or may be finished with contrasting texture, asphalt concrete, brick, or paving blocks as approved by the Engineer.
3. At least eight feet wide in business/commercial districts where most of the store frontage is within 80 feet of the street right-of-way. Where most of the store fronts are farther back than 80 feet the sidewalk shall be at least five feet in width.
4. With specified width greater than eight feet where Engineer determines this is warranted by expected pedestrian traffic volume.
5. With portland cement concrete surfacing as provided in Sections 3.03 and 4.01. See specifications for joints in Section 3.04 and Drawing No. 8.

### 3.03 Concrete for Curbs, Gutters, and Sidewalks

Concrete for curbs, gutters, and sidewalks shall be Class B, furnished and placed in accordance with MSDOT/APWA Standard Specifications, Sections 6-02, 8-04, and 8-14. Cold weather precautions as set forth in MSDOT/APWA Standard Specifications Sections 5-05.3(14) and 6-02.3(6)A shall apply.

### 3.04 Expansion and Dummy Joints. See Drawing No. 8

- A. An expansion joint consisting of 3/8" or 1/4" x full depth of preformed joint material shall be placed around fire hydrants, poles, posts, and utility castings and along walls or structures in paved areas.
- B. A dummy joint consisting of 1/8" or 3/16" x 2" of preformed joint material shall be placed in curbs and sidewalks at not over 15-foot intervals and at sides of drainage inlets. When curbs and/or sidewalks are placed by slip-forming, a preformed strip up to 1/2" thick and up to full depth may be used.
- C. Dummy joints in sidewalk shall be located so as to match the joints in the curb whether sidewalk is adjacent to curb or separated by planting strip.

D. Tool marks consisting of 1/4" V-grooves shall be made in sidewalk at 5-foot intervals, intermediate to the dummy joints.

E. As alternative to expansion joints around structures, reinforcing bars may be imbedded in concrete on four sides of structures.

F. Interface between curb and adjacent sidewalk shall be formed with 1/4" radius edging tool.

### 3.05 Curb Ramps

On all streets with vertical or rolled curb, ramped sections to facilitate passage of handicapped persons shall be constructed through curb and sidewalk at street intersections and other crosswalk locations. See Drawings No. 17 and 18. Where a ramp is constructed on one side of the street, a ramp shall also be provided at a corresponding location on the opposite side of the street.

### 3.06 Concrete Steps and Metal Handrail

When steps are required in sidewalk or access walk, concrete steps shall be constructed in accordance with Drawing No. 22 or other design acceptable to the Engineer and consistent with the Uniform Building Code. Handrails whether for steps or other applications, shall be provided consistent with Drawing No. 22 and the U.B.C.

### 3.07 Asphalt Walkways

A. In Urban Areas, asphalt walkways may be required adjacent to shoulder and ditch type streets as follows:

1. On both sides of all arterials, neighborhood collectors, multiple-dwelling and business access streets.

2. On one side of subcollectors, industrial access streets, and minor access streets (commercial), unless acceptable alternative off-street routes are provided for pedestrians.

B. In Rural Areas, asphalt walkways consisting of paved shoulders which may also serve as bikeways, may be required as follows:

1. On both sides of any arterials.

2. On one side of residential access streets in cluster developments only, when acceptable alternative off-street routes are not provided.

3. In Rural Activity Centers, in accordance with the Urban Area standards in Section 3.07A above.
- C. In all cases, asphalt walkways shall be constructed by paving the full width of the shoulder or, if separated from street, at least five feet in width, with surfacing as specified in Section 4.01. Where shoulders are paved on one side only, they shall be delineated by a 4-inch white edge line as approved by the Engineer.

### 3.08 Bikeways

- A. General. Normally, bikeways are shared with other transportation modes, although they may be provided exclusively for bicycle use. Bikeways are categorized as follows:
  1. Class I Bikeway (Bike Path): A separate trail for the principal use of bicycles.
  2. Class II Bikeway (Bike Lane): A portion of a road that is designated by signs and/or pavement markings for preferential bicycle use.
  3. Class III Bikeway (Bike Route): A road that is designated with signs as a bicycle route, where bicycle usage is shared with motor vehicles on the street or, less desirably, with pedestrians in a sidewalk or walkway.
  4. Class IV Bikeway (Shared Roadway): A publicly or privately maintained road that is not designated with signs and/or pavement markings as a bikeway, but is accessible for bicyclists.
- B. A Class I, II, or III Bikeway, as appropriate, should be provided:
  1. Wherever called for in the King County Comprehensive Plan, King County Transportation Plan, King County General Bicycle Plan, or adopted community plan, or
  2. When traffic analysis or traffic planning indicates substantial bicycle usage which would benefit from a designated bicycle facility.
- C. When the expected use of a road does not warrant Class I, II, or III Bikeway designation but does indicate significant bicycle traffic incidental to other traffic usage, then Class IV Bikeway considerations should apply. For example, a minimum four feet of paved shoulder with a standard edge stripe can enhance safety and convenience for both bicyclists and motorists on such routes. Other measures which may be considered include:
  1. Add 2 feet to width of outer travelled lane.
  2. Limit the use of traffic buttons.
  3. Ramp the approaches to bridge sidewalks.

D. In all cases the planning and design of bikeways in whatever category shall be in accordance with Section 337 of the WSDOT Design Manual.

### 3.09 Equestrian Lanes

- A. Equestrian lanes adjacent to the motor vehicle travelled way may be provided where proposed by a private group or required as a condition of approval by the County. Factors such as the following may be pertinent:
1. Horseback riding is a predominant community activity,
  2. Space or routing considerations do not warrant separate off-street equestrian trails,
  3. Traffic speed or volume makes it difficult or hazardous for horses to share travelled lanes with motor vehicles.
- B. For equestrian lanes adjacent to motor traffic lanes the following specifications shall apply:
1. Road shoulders intended for horseback use shall be surfaced full-width, minimum 4 feet, with minimum 2½ inches of crushed surfacing base course and 1½ inches of crushed surfacing top course. When constructed on existing shoulders of varying width, lanes eight feet wide are desirable, four feet minimum.
  2. Such lanes shall be signed one-way, with traffic.
  - C. When right-of-way permits, an equestrian lane may be constructed outside the ditchline or as a trail on an independent alignment. In either case such lane or trail shall be constructed at least eight feet wide and surfaced as indicated in Section 4.01F.

### 3.10 Off-Street Bikeways, Walkways, & Equestrian Trails

As a matter of policy, separate off-street facilities for bicyclists (Class I Bikeways), pedestrians, and horseback riders are encouraged wherever there is significant public demand for such facilities and space can be made available. Where off-street bikeways and walkways, or equestrian trails intersect with motorized traffic, sight distance, marking, and signalization (if warranted) shall be as provided in the MUTCD.

CHAPTER 4. SURFACING

4.01 Residential Streets, Pedestrian, Bike & Equestrian Facilities: The minimum paved section, with alternative combinations of materials, for residential streets, shoulders, sidewalks, bikeways, and equestrian trails shall be as indicated below. These sections are acceptable only on visually good, well-drained, stable compacted subgrade. Any proposed exception to these standards will be subject to soils test and traffic analysis at the expense of the developer and subsequent review by the Engineer as outlined in Section 4.02 below.

TYPE OF FACILITIES	ASPHALT CONCRETE		BITUM. SURF. TREAT. COURSE		CRUSHED SURF. TOP COURSE		CRUSHED SURF. BASE COURSE		PORTLAND CEMENT CONCRETE	
	<b>A. RESIDENTIAL ACCESS STREETS</b>									
Alternative I	.....	2"	(3" on Neighborhood Collectors)	.....	1 1/2"	.....	2 1/2"	.....	.....	.....
Alternative II	.....	5"	(6" on Neighborhood Collectors)	.....	.....	.....	.....	.....	.....	.....
Alternative III	(Acceptable for rural areas, transitional areas, and designated agricultural production districts only, on grades not steeper than 12.0%)									
Alternative IV	.....	.....	.....	.....	Class A	.....	1 1/2"	.....	2 1/2"	.....
Alternative V	.....	.....	.....	.....	.....	.....	.....	.....	.....	Class A 5" (6" on Neighborhood Collectors)
(Acceptable on Rural Minor Access Streets)	.....	.....	.....	.....	.....	.....	1 1/2"	.....	2 1/2"	.....
<b>B. SHOULDERS</b>										
Alternative I	.....	2"	(3" on Bus Routes)	.....	1 1/2"	.....	2 1/2"	.....	.....	.....
Alternative II	.....	5"	(6" on Bus Routes)	.....	1 1/2"	.....	2 1/2"	.....	.....	.....
Alternative III	.....	.....	.....	.....	Class A	.....	1 1/2"	.....	2 1/2"	.....
Alternative IV	.....	.....	.....	.....	.....	.....	1 1/2"	.....	2 1/2"	.....
<b>C. SIDEWALKS</b>										
Alternative I	(Acceptable except behind Rolled Curb)									
Alternative II	.....	.....	.....	.....	.....	.....	.....	.....	.....	Class B, 4"
(Mandatory behind Rolled Curb)	.....	.....	.....	.....	.....	.....	.....	.....	.....	Class B, 5"

TYPE OF FACILITIES	ASPHALT CONCRETE	BITUM. SURF. TREAT.	CRUSHED SURF. TOP COURSE	CRUSHED SURF. BASE COURSE	PORTLAND CEMENT CONCRETE
--------------------	---------------------	------------------------	--------------------------------	---------------------------------	--------------------------------

D. WALKWAYS & BIKEWAYS

Alternative I	2"		1½"	2½"	
Alternative II	3½"				
Alternative III		Class A	1½"	2½"	

When a walkway or bikeway is incorporated into a road shoulder, the required shoulder section, if higher strength, shall govern. Equestrian trails incorporated into road shoulders shall be constructed with crushed surfacing material as indicated in Alternative IV for Shoulders.

E. DRIVEWAYS may be surfaced the same as shoulders or as desired by the owner, except:

- (a) On curbed streets with sidewalks, driveway shall be paved with minimum five inches portland cement concrete Class A from curb to back edge of sidewalk; See Drawings No. 12 and 13.
- (b) On shoulder and ditch section, driveway between paved travel lane and property line shall be surfaced with material other than portland cement concrete; See Drawing No. 10.

F. EQUESTRIAN TRAILS, when separated from other traffic modes, shall be constructed on graded and compacted native soil. Existing soil which is not free-draining shall be removed and be replaced with free-draining soil. If heavy usage is anticipated, particularly in wet weather, the surface should be improved by adding crushed surfacing aggregate, cinders, or other materials which will tend to stabilize the surface while preserving its resiliency under hooved traffic.

#### 4.02 Requirements for Residential Streets on Poor Subgrade

The minimum material thicknesses indicated above are not acceptable if there is any evidence of instability in the subgrade. This includes free water, swamp conditions, fine-grained or organic soil, slides, or uneven settlement. If there are any of these characteristics, the soil shall be sampled and tested sufficiently to establish a pavement design that will support the proposed construction. Any deficiencies, including an R value of less than 55 or a CBR of less than 20, shall be fully considered in the design. Remedial measures may include a stronger paved section, a strengthening of subgrade by adding or substituting gravel base, more extensive drainage, or a combination of such measures. Both the soils test report and the resulting pavement design will be subject to review and approval by the Engineer.

#### 4.03 Arterials and Commercial Access Streets

The pavement of arterials and commercial access streets shall be designed with regard to the load bearing capacity of the soils and the traffic-carrying requirements of the roadway. Plans shall be accompanied by the soils and traffic analyses on which the design is based. Pavement sections shall not be less than those required for neighborhood collectors.

#### 4.04 Materials & Lay-Down Procedures: Shall be in accordance with WSDOT Standard Specifications and the following requirements:

- A. Asphalt treated base (ATB) may be substituted for asphalt concrete in temporary surfacing in the ratio of four parts thickness of ATB to three parts of asphalt concrete.
- B. ATB may be substituted for equal thickness of crushed surfacing top and base courses. Where base or top courses cannot be placed without possible contamination, then these courses shall be substituted by ATB.
- C. During surfacing activities utility covers in roadway shall be adjusted in accordance with Section 8.04.

#### 4.05 Pavement Marking

Where pavement markings are required, as determined by the Engineer, such markings shall be hot applied or cold applied thermoplastics, reflectorized, in accordance with Section 8-23 of the WSDOT Standard Specifications.

5.01 Rock Facings.

- A. Rock facings may be used for the protection of cut or fill embankments generally up to a maximum height of eight feet in stable soil conditions which will result in no significant foundation settlement or outward thrust upon the walls. See Drawings No. 19 through 21. For heights over eight feet or when soil is unstable, a structural wall of acceptable design shall be used. As an exception, rock facing heights may exceed eight feet to a limited extent subject to approval by the Engineer based on favorable soils analyses.
- B. Materials
  - 1. Size categories shall include:
    - Two-man rocks (300 to 600 pounds), 13" in least dimension;
    - Three-man rocks (800 to 1200 pounds), 16" in least dimension; and
    - Four-man rocks (1500 to 2200 pounds), 18" in least dimension.Four-man rocks shall be used for bottom course rock in all rock facings over six feet in height.
  - 2. The rock material shall be as nearly rectangular as possible. No stone shall be used which does not extend through the wall. The rock material shall be hard, sound, durable and free from weathered portions, seams, cracks and other defects. The rock density shall be a minimum of 160 pounds per cubic foot.
- C. The facing shall be started by excavating a trench one foot in depth below grade in excavation sections or below the existing ground level in embankment sections.
- D. Underdrains
  - 1. A six-inch minimum diameter perforated underdrain pipe shall be placed at the base of the wall as indicated in Drawings No. 19, 20, and 21. Actual pipe location can be varied as necessary to intercept the ground water effectively.
  - 2. Gravel backfill for drains shall be placed to a depth of 18 inches and surrounding the pipe.
  - 3. The perforated pipe shall be connected to the storm drain system or to an acceptable outfall.
  - 4. This pipe requirement may be waived by the Engineer upon a showing by the builder that no subsurface water problem exists.

E. Rock selection and placement shall be such that there will be minimum voids and, in the exposed face, no open voids over six inches across in any direction. The final course shall have a continuous appearance and be placed to minimize erosion of the backfill material. The larger rocks shall be placed at the base of the facing so that it will be stable and have a stable appearance. The rocks shall be placed in a manner such that the longitudinal axis of the rock shall be at right angles to the face. The rocks shall have all inclining faces sloping to the back of the facing. Each course of rocks shall be seated as tightly and evenly as possible on the course beneath. After setting each course of rock, all voids between the rocks shall be chinked on the back with quarry rock to eliminate any void sufficient to pass a two-inch-square probe.

F. The facing backfill shall consist of quarry spalls with a maximum size of four inches and a minimum size of two inches. This material shall be placed to an eight-inch minimum thickness between the entire facing and the cut or fill material. A filter fabric liner designed for permanent subsurface use shall be placed between the backfill spalls and the cut or fill materials. This requirement for fabric may be waived by the Engineer if shown that soils and water conditions make it unnecessary. The backfill material shall be placed in lifts to an elevation approximately six inches below the top of each course of rocks as they are placed, until the uppermost course is placed. Any backfill material on the bearing surface of one rock course shall be removed before setting the next course.

G. When a sidewalk is to be built over a rock facing, the top of the facing shall be sealed and leveled with a cap constructed of Cement Concrete Class C in accordance with the applicable provisions of Section 6-02 of the WSDOT/APWA Standard Specifications, but with reduced water content resulting in slump of not over two inches. See Drawing No. 21.

#### 5.02 Side Slopes

A. Side slopes shall generally be constructed no steeper than 2 to 1 on both fill slopes and cut slopes. Steeper slopes may be approved by the Engineer upon showing that the steeper slopes, based on soils analyses, will be stable.

B. Side slopes shall be stabilized by grass sod or seeding or by other planting or surfacing materials acceptable to the Engineer.

#### 5.03 Street Trees & Landscaping

A. As a matter of policy, street trees and landscaping should be incorporated into the design of any road improvement. Such landscaping in the right-of-way should be coordinated with off-street landscaping required on developer's property under the provisions of King County Code Chapter 21.51.

B. Trees shall generally be planted back of the sidewalk rather than in planting strips. Planting strips will be approved only as part of a landscaping plan in which plant maintenance, utilities, and traffic safety requirements are duly considered.

- C. Existing trees and landscaping should be preserved where desirable, and placement of new trees should be compatible with other features of the environment. In particular, maximum heights and spacing should not conflict unduly with overhead utilities, or root development with underground utilities. If street trees are planted, they should conform reasonably to standards in Drawing No. 23.
- D. New trees shall not include poplar, cottonwood, soft maples, gum, or any other tree or shrub whose roots are likely to obstruct sanitary or storm sewers. See King County Code 13.04.230.
- E. Street tree plans on bus routes shall be reviewed by Metro, phone 447-6319.

#### 5.04 Mail Boxes

- A. The responsibilities for location and installation of mailboxes in connection with the construction or reconstruction of County roads are as follows:
  - 1. County Road Engineer or his representative will:
    - a. Require road improvement plans, whether for construction by the Department of Public Works or by a private builder, to show clearly the designated location or relocation of mailboxes, whether single or in clusters.
    - b. Require with this information any necessary widening or reconfiguration of sidewalks with suitable knock-outs or open strips for mailbox posts or pedestal.
    - c. Require these plans to bear a statement on the first sheet that mailbox locations as shown on these plans have been coordinated with the serving post office at City/Community, Washington. This will be a prerequisite to plan approval.
    - d. Require construction of mailbox locations in accordance with these plans, through usual inspection and enforcement procedures.
  - 2. Seattle Postmaster or designated serving post office will:
    - a. Designate location and manner of grouping of mailboxes when so requested by the design agency. Note on the plans the type of mailbox delivery: NDCBU (Neighborhood Delivery and Collection Box Unit), or Rural type box. Authenticate by stamp or signature when these data have been correctly incorporated into the plans.
    - b. Do all necessary coordination with owners or residents involved to secure agreement as to mailbox location and to instruct them regarding mailbox installation. Actually install or relocate NDCBU's if these are the type of box to be used in the neighborhood.

3. Owners or residents served by mailboxes, at time of original installation, will:
  - a. If using individual mailboxes, clustered or separate, install and thereafter maintain their own mailboxes as instructed by the post office.
  - b. If NDCBU delivery, rely on Post Office to provide and maintain NDCBU's.
4. Builders or their contractors shall:
  - a. Where there are existing mailboxes and no plans to replace them with NDCBU's:
 

When it becomes necessary to remove or otherwise disturb existing mailboxes within the limits of any project, install the boxes temporarily in such a position that their function will not be impaired. After construction work has been completed, reinstall boxes at original locations or at new approved locations as indicated on the plans or as directed by the Engineer. Use only existing posts or materials except that any damage caused by the builder or his contractor is to be repaired at the expense of the builder.
  - b. Where there are existing NDCBU's or plans to install NDCBU's:
 

Call on Seattle Postmaster or designated serving post office to locate or relocate NDCBU's and make the necessary installation.
- B. U. S. Postal Service contact by mail is: Manager, Delivery and Collection; Post Office Box 9000; Seattle, WA 98109-9600. The phone number is 442-6170.
- C. Installation methods are as follows:
  1. Mailboxes, in the general case, shall be set in accordance with Drawing No. 24 or 25. Boxes shall be clustered together when practical and when reasonably convenient to the houses served.
  2. NDCBU's will be installed by the Postal Service generally in accordance with Drawing No. 26.

5.05 Street Illumination

Luminaires of suitable type and candlepower shall be provided where directed on arterials and as inter-section identifiers where other streets intersect arterials. Type of installation shall be as set forth in MSDOT/APWA Standard Specifications and as directed by the Engineer.

5.06 Survey Monuments

- A. All existing survey control monuments which are disturbed, lost, or destroyed during surveying or building shall be replaced by a land surveyor registered in the State of Washington at the expense of the responsible builder or developer.
- B. Survey control monuments shall be placed or replaced in accordance with recognized good practice in land surveying, and in conformance with Drawings No. 28 and 29.

5.07 Roadway Barricades

Temporary and permanent barricades shall conform to the standards described in Section 6C8 of the Manual on Uniform Traffic Control Devices (MUTCD) and Drawing No. 16.

- A. Type I or Type II barricades may be used when traffic is maintained through the area being constructed/reconstructed.
- B. Type III barricades may be used when roadways and/or proposed future roadways are closed to traffic. Type III barricades may extend completely across a roadway and its shoulders (as a fence) or from curb to curb. Where provision must be made for access of equipment and authorized vehicles, the Type III barricades may be provided with movable sections that can be closed when work is not in progress, or with indirect openings that will discourage public entry. Where jobsite access is provided through the Type III barricades, the developer/contractor shall assure proper closure at the end of each working day.
- C. In the general case, Type III permanent barricades shall be installed to close arterial roadways or other through streets hazardous to traffic. They shall also be used to close off lanes where tapers are not sufficiently delineated.
- D. Type I barricades may be used at the end of a local access street terminating abruptly without cul-de-sac bulb. Each such barricade should be used together with an end-of-road marker.

5.08 Bollards

When necessary to deny motor vehicle access to an easement, tract, or trail, except for maintenance or emergency vehicles, the point of access shall be closed by a line of bollards. These shall include one or more fixed bollards on each side of the traveled way and removable, locking bollards across the traveled way. Spacing shall provide one bollard on centerline of trail and other bollards spaced at intervals not to exceed 50 inches on centers. Bollard design shall be in accordance with Drawing No. 27 or other design acceptable to the Engineer. No fire apparatus access roads shall be blocked in this manner without the concurrence of the Fire Marshal.

5.09 Guardrail

Guardrail installations shall conform to State Standard Plan C-1, Beam Guardrail Type 1. End anchors shall conform to State Standard Plan C-2, Beam Guardrail Anchor Type 1.

5.10 Off-Street Parking Spaces

The number of off-street parking spaces required shall conform to King County Code Title 21.50 except for provisions of Section 2.03 Note 8 of these Standards for narrower widths of road. The specifications for off-street parking spaces shall be as provided in King County Code Title 16.74 and implementing document entitled "King County Specifications for Off-Street Parking, 1982," as updated.

5.11 Roadside Obstacles

Non-yielding or non-breakaway structures which may be potential hazards to the travelling public shall be placed with due regard to safety. On rural roadways with a shoulder or mountable curb section hazardous objects shall be placed as close to the right-of-way line as possible and a minimum of ten feet from the edge of the traveled way. On urban roads with a vertical curb section, hazardous objects shall be placed as far from the edge of the traveled way as practical. Such an object shall not be placed in a sidewalk or with the object edge nearest the roadway less than 8.5 feet from the face of the curb in business areas or 5.5 feet from face of curb in residential areas. Placement of any utility structures shall be in accordance with requirements of Chapter 8, to include constraints on placement of poles on the outside of curves.

## CHAPTER 6. BRIDGES

### 6.01 Principal References:

Except as specified below, King County bridges, whether on public roads or on private roads serving subdivided land, shall be designed and constructed to meet the minimum requirements set forth in the latest edition, including all interim addenda, of "Standard Specifications for Highway Bridges," adopted by AASHTO. Bridge and approach railings shall be provided in accordance with that reference or with AASHTO "Guide for Selecting, Locating, and Designing Traffic Barriers." All new bridges shall be designed to carry an AASHTO HS 20-44 live load or greater.

### 6.02 Bridge Geometrics:

- A. In the general case, the bridge roadway shall comprise the full width and configuration of the road being served -- traveled way plus curb, sidewalks, walkway, bike lane, equestrian lane, and/or shoulder on one or both sides. Requirements of utilities shall be duly considered. Bridge roadway width shall be measured between curbs or between faces of rails, whichever is less, but in no case shall be less than 28 feet.
- B. Where typical speed is 35 MPH or higher and significant pedestrian, bike and/or horseback traffic can be expected, the Engineer may require that the lanes for these other modes of traffic be separated from motor vehicle traffic by use of a bridge traffic rail and further protected by a rail at outer edge. See the WSDOT Design Manual, particularly Section 330.04(5).
- C. Approach railings shall be made structurally continuous with bridge railings and shall meet AASHTO specifications as cited in Section 6.01 above.
- D. Overhead vertical clearances for motor traffic on the traveled roadway or under overpasses shall be 16.5 feet minimum. Vertical clearance of structures above a walkway or sidewalk shall be eight feet minimum.

### 6.03 Bridge Design Criteria:

- A. Approach slabs will be required for all bridges and new bridge plans shall provide pavement seats for approach slabs unless otherwise approved by the Engineer. Waiver of the requirement for approach slabs will be considered only on the basis of adequate geotechnical analysis. Approach slabs shall be constructed in accordance with WSDOT Standard Plan A-2.
- B. New bridge decks and approach slabs shall be designed with a protective system to prevent corrosion of the reinforcing steel.

- C. Criteria under other recognized road and bridge project classifications, such as those of 3-R projects, set forth in WSDOT Local Agency Guidelines, may be applied under conditions deemed appropriate by the Engineer.

#### 6.04 Special Permits:

Permit requirements for construction or reconstruction of bridges include but are not limited to the following:

- A. Bridges over navigable waters require U. S. Coast Guard permits.
- B. Bridges involving deposition of material in waters of the United States or their adjacent wetlands require a U. S. Army Corps of Engineers Permit.
- C. Any work involving alteration of flow or bed materials below the ordinary high water line of any water body or water course requires a Hydraulic Project approval from the State Department of Fisheries or the State Department of Game.
- D. Any project requiring a U. S. Army Corps of Engineers Permit also requires Water Quality Certification from the State Department of Ecology.
- E. Bridges across streams in State Flood Control Zones require a permit from the State Department of Ecology issued through the County Department of Public Works, Surface Water Management Division.
- F. Where Bridge structures lie on or over submerged lands a lease from the Washington State Department of Natural Resources may be necessary.
- G. Structures located on shoreline zones as defined in King County Code Title 25 require a substantial development permit from the King County Division of Building and Land Development, subject to concurrence of the State Department of Ecology.
- H. Bridges over waterways require the Engineer's approval of the size and shape of the hydraulic opening, the height of the superstructure over high water, the location of piers, channel improvement, and other hydraulic considerations.

CHAPTER 7. DRAINAGE

7.01 Drainage Plan

Drainage facilities on County roads shall conform to Division 7 of the MSDOT/APWA Standard Specifications unless otherwise stated. Such facilities shall also be consistent with King County Code 20.50 and implementing guidelines on drainage prepared by Surface Water Management Division, King County Department of Public Works and referred to in these Standards as "Drainage Guidelines." Note the requirement therein for a drainage plan.

7.02 Drainage Methods in Shoulder

- A. On grades up to 6%, grass-lined ditches, with grass materials acceptable to the Engineer, shall be used for the drainage requirement. These ditches shall be designed and constructed in accordance with the Drainage Guidelines and Drawings No. 1, 4, and 7 of the Standards. If grass cannot be readily established by usual seeding method, other methods such as sodding or seeding with slope mat protection shall be used as necessary. Driveway culverts shall be in accordance with Drawing No. 10 and notes thereon.
- B. Where the grade is over 6% and not over 9%, the Engineer may direct use of a standard rocklined ditch or alternatively a closed (pipe) drainage system under a paved shoulder with asphalt curb or turnpike shoulder. As an exception, cul-de-sacs with over 6% grade shall be provided with pipe drainage and not with rocklined ditches.
  - 1. The standard rock lining shall be in accordance with the Drainage Guidelines and Section 9-13.1 of the MSDOT/APWA Standard Specifications. Rock gradation shall be as follows:

Passing 8-inch square sieve	100%
Passing 2-inch square sieve	0-10%
- 2. The asphalt curbed or turnpike shoulder shall be consistent with examples in Drawing No. 51. Actual dimensions of section, spacing of inlets, and size of pipe shall be based on calculated stormwater flow. Surfacing of section shall be as for paved shoulder, Section 4.01B, Alternatives I, II or III.

7.03 Storm Sewers and Culverts

- C. Where the grade exceeds 9% either pipe drainage shall be provided or a special rock-lined ditch unless otherwise approved by the Engineer. The special rock-lined ditch shall be designed by a professional civil engineer, based on soils and hydraulic analyses. Design shall include rock sizing, together with filter rock gradations and/or filter fabric, and be subject to approval by the Engineer.
- D. Under exceptional conditions of erodibility or water velocity, the Engineer may direct more stringent methods to control erosion. On short runs, e.g., under 300 feet, which limit water volume and velocity, the Engineer may permit less stringent methods of control.
- A. Underground storm drainage shall be provided for curb street section on grades 1% and steeper whenever the length of surface drainage exceeds 300 feet on road grade extending either direction from crest or sag on vertical curves. Where road grade is under 1%, the maximum unpiped run shall be 150 feet. For inlet intervals see section 7.06A below.
- B. Storm sewer pipe other than pipe connecting street inlets cross-street to main storm sewer shall be minimum 12-inch diameter. Runoff shall be computed and, if the flow requires it, larger pipe shall be used.
- C. On cross-street connections tying single inlets to main storm sewer by structure, i.e., catch basins, generally pipe shall be minimum 12-inch diameter, and single inlets shall be catch basins with sumps. In special cases such as shallow gradient or conflict with underground utilities, pipe may be minimum 8-inch diameter, to maximum length of 60 feet, and inlet may be simple inlet (Drawing No. 40).
- D. Connections of storm sewer pipe leading from a street inlet location may be made into a main storm sewer without structure, subject to case-by-case approval by the Engineer and subject to the following requirements:
  - 1. The inletting structure shall be catch basin and not a simple inlet lacking a catch or drop section.
  - 2. Outside diameter of inlet pipe shall not exceed one-half the inside diameter of the main storm sewer.
  - 3. Length of inlet connection shall not exceed 60 feet.
  - 4. Standard shop-fabricated tees, wyes, and saddles shall be used, except that connections with concrete pipe may be field-tapped in accordance with Drawing No. 30.

- E. Pipe materials and installation for culverts and storm sewers shall be as indicated in WSDOT/APWA Standard Specifications Sections 7-02 and 7.04, respectively, and AASHTO specifications. These include the following, with references to particular requirements in the WSDOT/APWA Standard Specifications and AASHTO:
- |  |                          |
|--|--------------------------|
| Plain Concrete Storm Sewer Pipe                                    | Section 9-05.7(1)        |
| Reinforced Concrete Storm sewer Pipe                               | Section 9-05.7(2)        |
| Aluminized Type 2 Corrugated Steel                                 | AASHTO M274 and M36      |
| Steel Spiral Rib Storm Sewer Pipe                                  | Section 9-05.9           |
| Zinc Coated (Galvanized) Corrugated Iron or Steel Storm Sewer Pipe | Section 9-05.10 & 9-05.4 |
| Corrugated Aluminum Storm Sewer Pipe                               | Section 9-05.11 & 9-05.5 |
| Aluminum Spiral Rib Storm Sewer Pipe                               | Section 9-05.17          |
1. Galvanized corrugated steel pipe shall have asphalt coating Treatment 1 as specified in State Standard Specifications Section 9-05.4(3). Aluminized steel pipe may be used without Treatment 1.
  2. In private development the use of other types of pipe such as corrugated polyethylene or other plastic varieties is not precluded in storm sewers and culverts except where these storm sewers and culverts are or can reasonably be expected to become part of the County maintained drainage system.
- F. Generally, all pipe shall be tightly joined. Concrete pipe shall be rubber-gasketed in accordance with Section 9-05.7(3) of the WSDOT/APWA Standard Specifications. Metal pipe shall be gasketed and securely banded. WSDOT Standard Plans No. B-13a, b, c, and d apply.
- G. Leak testing as set forth in Section 7-04.3(4) of the State Standard Specifications will not be required unless specified by the Engineer.
- H. Storm drain gradients shall be such as to assure minimum flow velocity of three feet per second when flowing full.
- I. A drainage easement shall be located entirely within a single lot or tract, except where linear extent of the drain line may involve additional properties in sequence.
- J. On driveway culverts and cross culverts, pipe ends projecting from driveway side slopes or roadway foreslopes shall be beveled as shown in Drawing No. 11. Pipes stubbing out from the drainage system and exiting outside the roadway, or in areas not accessible to errant vehicles, need not be beveled and should be concrete.
- K. Consistent with the King County Comprehensive Plan, Policy E-324, natural streams shall not be placed into pipe except for essential roadway crossings.

7.04 Drains

Drains, including underdrains, shall conform to Section 7-01 of the MSDOT/APWA Standard Specifications. Authorized pipe materials for drains include, in addition to the concrete and metal types cited in Section 7.03 above, various kinds of plastic pipe.

7.05 Filter Fabric for Drains

Filter fabric shall be placed in underdrain trenches in accordance with the details shown in the plans and these special provisions. Fabric filters for subsurface drainage shall be composed of strong rot-proof, woven or nonwoven, polymeric fibers oriented into a stable network such that the fibers retain their positions with respect to each other. The fabric shall be free of any chemical treatment or coating which may significantly reduce permeability, and shall have no flaws or defects which could significantly alter its physical properties. The fabric shall be laid out with a minimum overlap of one foot at the edge. The following fabric physical property requirements must be met:

PROPERTY	VALUE	TEST METHOD
<u>Grab Tensile Elongation</u>	25% Min.	ASTM D-1682-64
<u>Grab Tensile Strength</u>	125 psi	ASTM D-1682-64
<u>Mullen Burst Strength</u>	125 psi	ASTM D-3786-80a
<u>Trapezoid Tear Strength</u>	60 lbs.	ASTM D-1117-80

7.06 Catch Basins, Manholes, and Inlets

- A. Maximum spacing on surface drainage courses between inlets or catch basins shall be 150 feet on road grades less than 1.0% and 200 feet on grades from 1% up to 3.0%. When road grade is 3.0% or greater, maximum spacing shall be 300 feet. Additional catch basins shall be installed as needed to confine drainage to the gutter and prevent street drainage from sheet flowing across roadways or intersections.
- B. Maximum spacing on main storm sewers between access structures, whether catch basins or manholes, shall be 300 feet.
- C. On storm sewers with depths less than five feet to invert of lowest pipe, catch basins may be one of the following:
  - Catch Basin Type 1 (Drawing No. 31)
  - Catch Basin Type 1-L (Drawing No. 32)
  - Catch Basin Type 2 (Drawing No. 33)

D. On storm sewers with depths five feet and over to invert of lowest pipe, joining or inletting structures shall be catch basin Type 2 (Drawing No. 33) in appropriate size. Reinforcing details for catch basin top slabs are shown in Drawing No. 34 or No. 39 as applicable for shape of lid. With approval by the Engineer, a pre-cast cone may be substituted for the top slab.

E. Where a structure is needed for access or for juncture of storm sewers, but not for catchment of silt, the structure shall be one of the following types of manhole in suitable size:

- Manhole Type 1 (Drawing No. 35)
- Manhole Type 2 (Drawing No. 36)
- Manhole Type 3 (Drawing No. 37)
- Manhole Type 4 (Drawing No. 38)

Reinforcing details for manhole top slabs are shown in Drawing No. 39.

F. Extension sections or risers shall be installed as indicated in drawings for catch basins and manholes.

G. Catch basin and manhole ladders, steps, and handholds shall conform to Drawing No. 39. The step location shall conform to Drawings No. 33, 35, 36, 37, and 38 or as shown on approved plans.

H. Section 7-05 of the WSDOT/APWA Standard Specifications shall apply, unless otherwise specified, to catch basins and curb inlets as well as manholes.

I. On new subdivisions with curb and sidewalk adequate measures shall be taken to control surface drainage from yards and roof drains so that sheet flow across roadways and walkways is avoided. As a minimum, such measures may include a 4-inch minimum pipe laid subsurface from permanent roadway catch basins to a point one foot behind the curb or sidewalk at the lowest front corner of each lot requiring retention or drains onto street. The pipe shall be capped and marked to provide for future connection during house construction.

7.07 Frames, Grates, and Covers

A. On drainage structures under vertical curb and gutter, under average conditions, the frame and grate shall be 18" x 24" cast iron grate and frame (Drawings No. 42 and 41). When catch basin Type 1 or 2 does not serve as inlet, a solid cover, (Drawing No. 43) shall be used. Frame and grate or lid shall be incorporated into curb and gutter section as shown on Drawing No. 42.

- B. Where grade is 6% or over on vertical curb and gutter the vaned grate, (Drawing No. 46) in ductile iron shall be used. A proprietary spring-locking version of this grate available from Olympic Foundry is an acceptable alternative except on a through-curb inlet, subject to approval by the Engineer.
- C. On drainage structures under vertical curb and gutter, a through-curb inlet frame, (Drawing No. 44) shall be used where conditions severely limit the effectiveness of a flat surface inlet. Examples of such conditions are road grades exceeding 12% and likelihood of clogging from leaf fall or other debris, especially in sag vertical curves.
1. When used with this through-curb inlet frame, the grate shall be the vaned grate in ductile iron (Drawing No. 46), except that standard grate (Drawing No. 41) in ductile iron may be used at bottom of sag vertical curves.
2. Installation of the through-curb inlet shall be as shown in Drawing No. 45.
- D. On drainage structures taking run-off from rolled curb, a rolled curb inlet, frame and grate (Drawing No. 47) shall be used. This gutter inlet shall be installed to grade with road and curb constructed to match the inlet at front and back, as shown in Drawing No. 48.
- E. On new catch basins Type 2 not serving as inlets and on manholes functioning exclusively as access structures round locking 24" cover and frame (Drawings No. 49 and 50) shall be used. Note that manhole "ring" and "frame" are interchangeable terms.
- F. Block lettering is required on top surfaces of grates and covers as follows:
1. "DRAIN" -- 2" letters on all solid covers.
  2. "OUTFALL TO STREAM DUMP NO POLLUTANTS" --  $\frac{1}{2}$ " letters on all grates.
  3. "PROPERTY OF KING COUNTY" --  $\frac{1}{4}$ " letters on grates and on solid cover but only in facility owned or maintained by King County.
  4. "PROPERTY OF KING COUNTY" -- 1-inch letters on round solid cover, but only in facility owned or maintained by King County.
- G. Locking bolts shall be provided and frames shall be drilled and tapped to receive them:
1. For all solid covers, round or rectangular.
  2. For rectangular grates, except rolled curb type, for extra security, when specified.
- See Drawings No. 41, 42, 43, 44, 46, 49, and 50. Other locking devices such as Olympic Foundry Self-Lock Vaned Grate SM50SL are acceptable subject to approval by the Engineer.

- H. Unless otherwise specified, cast (gray) iron products shall conform to ASTM Designation A48 Class 30 and ductile iron to ASTM Designation A536 Grade 80-55-06. Strength requirements of Federal Specification RR-F-621D will apply.

#### 7.08 Other Types and Materials

Subject to approval by the Engineer, other types and materials of pipe, filter fabric, drainage structures, and drainage hardware may be used provided that recognized specifications are available to control quality and acceptable user experience with the product can be shown.

#### 7.09 Runoff Control Policies

The following elements of King County Code 20.50 and the Drainage Guidelines are excerpted for information. If inconsistencies appear, the specific wording of the Code and the Guidelines shall control.

A. **Runoff Diversion:** Surface water entering the subject property or project area shall be received at the naturally occurring location. Surface water exiting in this area shall be discharged at the natural location with adequate energy dissipators to minimize downstream damage. There shall be no diversion at either of these points. In subdivisions, these rules shall apply to the total property which is under development and not just to the proposed road right-of-way.

#### B. **Peak Discharge Control:**

1. The peak discharge for the design year storm from the road right-of-way or from total developed property as provided in Section 7.09A above shall not be increased due to the proposed construction, and
2. Retention or detention facilities acceptable to the Engineer shall be provided in order to handle all surface water in excess of the peak discharge.

C. **Flow Restrictor/Oil Pollution (FROP) Control Device:** A FROP control device, or simply "FROP," shall be installed when one or both of the following conditions exist in the storm drainage system:

1. Excessive peak flows which must be controlled in accordance with Section 7.09A and B above.
2. Potential significant contamination of runoff with oil or grease.

The FROP shall be located at a point where it can function and be maintained effectively. It shall be constructed and installed in accordance with Drawing No. 52, the "Tee" type, or, alternatively, Drawing No. 54, the "Baffle" type, or as specified or approved by the Engineer. The FROP shall be provided with a solid, round, locking lid. It shall be so located and installed that no storm drainage will enter the structure through the access hole or the top slab or risers.

D. Erosion and Siltation Control: In addition to catch basins as provided in Section 7.06, measures such as the following shall be taken as necessary during and after construction to prevent erosion and to prevent silt from being carried offsite and/or into bodies of water:

1. Excavation and grading shall be done in a manner to maintain controlled drainage of the worksite and to minimize the exposure of unprotected slopes to the action of precipitation or flowing ground water.
2. Where possible, existing natural vegetation shall be left intact.
3. Exposed slopes when completed shall be given appropriate permanent protection as soon as practical, e.g., grass or other groundcover, riprap, rock walls, or retaining walls.
4. The provisions of the Drainage Guidelines include the submittal of an effective erosion/sedimentation control plan to be approved by the Engineer prior to starting any clearing and grubbing or earthwork.

#### 7.10 Storm Drainage Trenches

The excavation, bedding, backfill, and compaction requirements for storm drainage trenches are as set forth in Section 7-17.3(3) of WSDOT/APWA Standard Specifications and Section 8.03 of these Road Standards, for utilities. Backfill compaction shall be by mechanical means.

## CHAPTER 8. UTILITIES

### 8.01 Franchising Policy and Permit Procedure

- A. Utilities to be located within existing and proposed County road right-of-way shall be constructed in accordance with current franchise and/or permit procedure and in compliance with these Standards. In their use of the right-of-way, utilities will be given consideration in concert with the traffic carrying requirements of the roadway which are, namely, to provide safe, efficient and convenient passage for motor vehicles, pedestrians, and other transportation uses. Aesthetics shall be a consideration. As a matter of policy, undergrounding of electric utilities will be strongly encouraged, particularly in urban development. Also, utilities are subject to County policies relating to drainage and erosion/sedimentation control as set forth in KCC 20.50 and Drainage Guidelines.
- B. All permits for new placement and replacement of existing utility poles and other utility structures above grade shall be accompanied by written certification from a Washington State professional engineer or from an agent authorized by the utility to certify, that the installations conform to these Standards and that the proposed work is in conformity with sound engineering principles relating to highway safety.
- C. Requests for exceptions to these Standards will be processed in accordance with variance procedure as referenced in Section 1.08.

### 8.02 Standard Utility Locations Within the Right-of-Way

Utilities within the right-of-way on new roads or in roadways where existing topography, utilities, or storm drains are not in conflict, shall be located as shown in typical sections, Drawings No. 1 through 6, and as indicated below. Where existing utilities or storm drains are in place, new utilities shall conform to these Standards as nearly as practicable and yet be compatible with the existing installations.

#### A. Gas and Water Lines:

1. Shoulder-and-Ditch Section:  
If practical: Outside of ditch line.  
Otherwise: In shoulder three feet from edge of travelled lane.
2. Curb and Gutter Section:  
Preferable: 1.5 feet back of curb, or at distance which will clear root masses of street trees if these are present or anticipated.  
Otherwise: In the street as close to the curb as practical without encroaching on the storm drainage system. Mains and service connections to all lots shall be completed prior to placing of surface materials.

3. Designated Side of Centerline:  
GAS: South and West; WATER: North and East
4. Depth: 30 inches minimum cover from finished grade.
- B. Individual water service lines shall:
  1. Be placed with minimum 30-inch cover from finished grade.
  2. Use road right-of-way only as necessary to make side connections.
  3. For any one connection not extend more than 60 feet along or through the right-of-way, or the minimum width of the existing right-of-way.
- C. Sanitary Sewers: In the general case, 5 feet south and west of centerline; depth 4 feet minimum cover from finished grade.
- D. In the case of individual sanitary sewer service lines which are force mains the pipe shall:
  1. Be minimum 2 inches I.D.
  2. If nonmetallic, contain wire or other acceptable proximity detection features; or be placed in a cast iron or other acceptable metal casing.
  3. Be placed with minimum 4-foot cover from finished grade, within 10° of perpendicular to road centerline, and extend to right-of-way line.
  4. Be jacked or bored under roadway unless otherwise approved by the Engineer.
- E. Sanitary and water lines shall be separated in accordance with good engineering practice such as the Recommended Standards for Waterworks, a Committee Report of the Great Lakes - Upper Mississippi River Board of State Sanitary Engineers, known as the "10-State Standard," specifically Section 8.6 (1982 Edition).
- F. Gravity systems, whether sanitary or storm drainage, shall have precedence over other systems in planning and installation except where a non-gravity system has already been installed under previous approved permit and subject to applicable provisions of such permits or franchises.
- G. Electric utilities, power, telephone, cable TV: Preferable: Underground, either side of road, at plan location and depth compatible with other utilities and storm drains. Otherwise: Every new placement and every replacement of existing utility poles and other utility structures above grade shall conform to the following:

1. Utility poles or other obstacles may be placed within the right-of-way and shall be as far back from the traveled way as practicable.  
On shoulder type roads, poles or obstacles shall be located back of ditches and in accordance with criteria in Drawing No. 15 unless protected by guardrail, concrete barrier, or suitable impact attenuating devices.  
On curb type roads, poles or obstacles shall be placed clear of sidewalks and at least 8.5 feet from face of curb in business areas and 5.5 feet from curb face in residential areas, unless barricaded.
2. The above constraints on pole location will not apply to locations not accessible by moving vehicles, nor to "breakaway" structures whose break-off resistance does not exceed that of 4" x 4" wood post or a 1-1/2" standard (hollow) iron pipe.
3. Deviations from these pole clearance criteria may be allowed when justified by suitable engineering study considering traffic safety.
4. Locations of poles shall also be compatible with driveways, intersections, and other roadway features (i.e., they shall not interfere with sight distances, roadway signing, traffic signals, culverts, etc.). To the extent possible, utilities shall share facilities so that a minimum number of poles is needed.
5. Where road uses leave insufficient overhang, anchor, and tree-trimming space for overhead utilities, consideration will be given to variance from the Standards or to acquisition of additional easements and/or right-of-way for this purpose. Costs incurred for said acquisition shall be borne by the developer, builder, or other party initiating the road construction. However, the associated cost of relocating the utility shall not be borne by King County.
- H. Notwithstanding other provisions, underground systems shall be located at least 5 feet away from road centerline and where they will not otherwise disturb existing survey monumentation.

#### 8.03 Underground Utility Installation

- A. General. The WSDOT/APWA Standard Specifications, particularly Section 7-17.3(3) will generally apply unless otherwise stated below.
- B. On Existing Travelled Roadways, i.e., Utility Cuts:
  1. In trenching through existing pavement, the open cut shall be a neat-line cut made by either saw cutting or jackhammering a continuous line. Trench sides shall be kept as nearly vertical as possible. Compaction and restoration must be done as detailed below and immediately after the trench is backfilled, so as to cause least disruption to traffic. Cement concrete pavement shall be cut 1-foot outside the edge of the trench on each side.

2. In cuts parallel to road alignment:
  - a. All trench backfill under roadway shall be mechanically compacted to 95% of maximum density except for trenches over eight feet in depth. Throughout the length of any pipe run, manhole to manhole, in which any part is over 8 feet deep, backfill at depths over 4 feet shall be compacted to 90% maximum density by either water settling (see Subsection 8.03C below) or mechanical compaction. The top 4 feet of the trench line shall then be mechanically compacted to 95%. All densities shall be determined by testing specified in Section 2-03.3(14)D of WSDOT/APWA Standard Specifications.
  - b. In any trench in which 95% density cannot be achieved with existing backfill, the top four feet shall be replaced with gravel base as specified in the WSDOT/APWA Standard Specifications, Section 9-03.10. This new material shall then be mechanically compacted to 95%.
  - c. Restoration on an asphalt pavement shall include a minimum of 4 inches of crushed surfacing material and 2 inches of asphalt concrete Class B or comparable surfacing approved by the Engineer. Roadway shall then be overlaid full width with a minimum of 1 inch compacted asphalt concrete Class B. Any exceptions to this overlay requirement will be on a case-by-case basis, subject to approval by the Engineer, considering the existing conditions of the roadway. Concrete pavement shall be restored consistent with Section 5-05 of the WSDOT/APWA Standard Specifications. Any traffic lane affected by the trenching shall be replaced full-width.
3. In cuts transverse to road alignment:
  - a. In general, utility trenching through existing pavement across the road alignment will be discouraged. It will not be permitted unless it can be shown that alternatives such as boring or jacking are infeasible, or unless the utility can be installed just prior to reconstruction or overlay of the road.
  - b. Without exception, the entire trench shall be backfilled with gravel backfill for pipe bedding (pea gravel) or crushed surfacing top course meeting the requirements of Sections 9-03.12(3) and 9-03.9(3) of the WSDOT/APWA Standard Specifications respectively. Backfill shall be placed and compacted mechanically in 1-foot lifts with a County inspector present. After backfill and compaction, an immediate cold mix patch shall be placed and maintained in a manner acceptable to the Engineer. On asphalt pavement, a permanent hot mix patch the same thickness as the original asphalt or a minimum of 2 inches, whichever is the greater, shall be placed and sealed with a paving grade asphalt within 30 calendar days. Cement concrete pavement shall be restored with an 8-sack mix, using either Type II or Type III cement, within 30 calendar days.

C. On Proposed Travelled Roadways (e.g., New Subdivisions): When working in areas of proposed traveled County roadway, backfill compaction may be achieved throughout the entire depth of the trench either by mechanical compaction as described in B.2 above, or by the following alternative method, namely, water settling:

1. Where water settling of trenches is done, the jetting method shall be used. In trenches over 8 feet deep the Engineer may direct the backfill to be placed in 2 or more lifts and each be jetted separately. Jets shall be inserted at not more than 4-foot intervals throughout the length of the backfilled area and shall be slowly forced, on the first lift, down to the bottom of the trench and held until the trench backfill is completely saturated with water. Penetration shall be to the crown of the pipe, to native ground on side slopes, and subsequently to each preceding lift. The jetting operations shall be completed as soon as practicable after the pipe laying and as part of the backfilling operations.
2. After the water-settled trench has set for several days and the backfill is visibly dry, firm, and stabilized, any depression in the trench shall be filled and mounded up over the trench. It shall then be further compacted by the use of acceptable vibratory compaction equipment capable of breaking any bridging which may have occurred.
3. The minimum size of hose and equipment shall be such as to provide not less than 35 pounds per square inch pressure at the discharge. The jet shall be rigid iron pipe with a minimum inside diameter of 1 inch.
4. Source of water will depend upon local conditions. Hydrants or surface water sources shall be utilized when such sources of water exist within 700 feet of the operations. Hauled water may be utilized when the water settling operation is more than 700 feet from a hydrant.

D. Testing:

1. Consistent with the above and prior to placing any surface materials on the roadway, it shall be the responsibility of the developer to provide density test reports certified by a professional engineer registered in the State of Washington. A minimum of one test shall be taken within every 500 feet of trench length and at depths up to 50% of trench depth, or as directed by the County Road Engineer. Compaction of laterals or service line trenches shall be tested where directed by the County Road Engineer.
2. Whichever compaction method the installer elects, the backfill below four feet must test to be not less than 90% maximum density and the upper 4 feet of backfill must test not less than 95% maximum density. Where this cannot be achieved, all affected backfill in the top 4 feet shall be removed and replaced by gravel base and mechanically compacted to 95% as in B.2 above.

E. Notification and Inspection:

1. Consistent with Section 9.02 of these Standards, any developers, utilities, or others intending to trench in existing or proposed travelled County roadway shall notify King County Development Inspection or Utility Inspection office not less than 1 working day prior to doing the work. This notification shall include:

- a. Location of the work
- b. Method of compaction to be used
- c. Day and hour when compaction is to be done
- d. Day and hour when testing is to be done.

Phones are as follows:

King County Development Inspection Section  
King County Utility Inspection Section

255-2531  
244-0770

2. As set forth in section 9.03 of these Standards, failure to notify may necessitate testing or retesting by King County at the expense of the developer or utility. Furthermore, the work may be suspended pending satisfactory test results.

8.04 Final Utility Adjustment (To Finish Grade)

- A. All utility covers which are located on proposed asphalt roadways shall be temporarily placed at subgrade elevation prior to placing crushed surfacing material.
- B. Final adjustment of all covers and access entries shall be made following final paving by:
  1. Saw-cutting or heat-line jackhammering of the pavement around lids and covers. Opening should not be larger than 12 inches beyond the radius of the cover.
  2. Removing base material, surfacing course, and frame; adding raising bricks; replacing frame and cover to finish grade.
  3. Filling and mechanically compacting around the structure and frame with crushed surfacing material or ATB, or pouring in 5-inch minimum thickness of concrete to within 2 inches of the top.
  4. Filling the remaining 2 inches with asphalt concrete Class B hot mix, compacted and sealed to provide a dense, uniform surface.

8.05 Final Cleanup, Restoration of Surface Drainage, and Erosion Control

In addition to restoration of the roadway as described above, the responsible utility shall care for adjacent areas in compliance with sections 1-04.11 "Final Cleanup" and 8-01 "Roadside Seeding" in the MSDOT/APWA Standard Specifications. In particular:

- A. Streets and roadways shall be cleaned and swept both during and after the installation work.
- B. Disturbed soils shall be final graded, seeded and mulched after installation of utility. In limited areas seeding and mulching by hand, using approved methods, will be acceptable.
- C. Ditch lines with erodible soil and subject to rapid flows may require seeding, jute matting, netting, or rock lining to control erosion.
- D. Any siting of downstream drainage facilities, whether ditches or pipe and catch basins, which results from the utility installation shall be cleaned out and the work site restored to a stable condition as part of site cleanup.

## CHAPTER 9. CONSTRUCTION CONTROL AND INSPECTION

### 9.01 Basis for Control of the Work

- A. Work performed in the construction or improvement of County roads, whether by or for a private developer, by County forces, or by County contractor, shall be done to the satisfaction of the Engineer and in accordance with approved plans (Section 1.07). It is emphasized that no work may be started until such plans are approved. Any revision to such plans shall be approved by the Engineer before being implemented.
- B. The Engineer will have authority to enforce the Standards as well as other referenced or pertinent specifications. He will appoint project engineers, assistants, and inspectors as necessary to inspect the work and they will exercise such authority as the Engineer may delegate.
- C. Provisions of Section 1-05 of the WSDOT/APWA Standard Specifications shall apply, with the term "Engineer" therein construed to be the County Road Engineer as defined in Section 1.10 of the County Road Standards.

### 9.02 Subdivision and Commercial Development Inspection

On all road and drainage facility construction, proposed or in progress, which relates to subdivision and commercial development, control and inspection will be done by the Development Inspection Section, hereafter called DIS, acting for the County Road Engineer. Unless otherwise instructed by the Engineer, construction events which require monitoring or inspection by DIS are identified as follows, with prior notification to DIS (telephone 255-2531):

- A. Preconstruction Conference: Three working days prior notice. Conference must precede the beginning of construction and include contractor, designing engineer, utilities, and other parties affected. Plan approvals and permits must be in hand prior to the conference.
- B. Clearing and Temporary Erosion/Sedimentation Control: One working day notice prior to initial site work involving drainage and installation of temporary water retention/detention and siltation control. Such work to be in accordance with Section 7.09D and the approved plans.
- C. Utility and Storm-Drainage Installation: One working day notice prior to trenching and placing of storm sewers and underground utilities such as sanitary, water, gas, power, telephone, and TV lines. For utilities see also Section 8.03E.
- D. Utility and Storm Drainage Backfill and Compaction: One working day notice before backfill and compaction of storm sewers and underground utilities.

- E. Subgrade Completion. One working day notice at stage that underground utilities and roadway grading are complete, to include placement of gravel base if required. Inspection to include compaction tests and certifications described in Sections 8.03 and 9.04.
- F. Curb and Sidewalk Forming: One working day notice to verify proper forming and preparation prior to pouring concrete.
- G. Curb and Sidewalk Placement: One working day notice to check placement of concrete.
- H. Crushed Surfacing Placement: One working day notice to check placement and compaction of crushed surfacing base course and top course.
- I. Paving: Three working days notice in advance of paving with asphalt or portland cement concrete.
- J. Structural: Three working days notice prior to each of critical stages such as placing foundation piling or footings, placement and assembly of major components, and completion of structure and approaches. Tests and certification requirements will be as directed by the Engineer.
- K. Final Inspection: Fifteen working days prior to overall check of roadway or drainage project site, to include completion of paving and associated appurtenances and improvements, cleaning of drainage system, and all necessary clean-up.

9.03 Penalties for Failure to Notify for Development Inspection

Timely notification by the developer as noted above is essential for the County to verify through inspection that the work meets the standard. Failure to notify in time may oblige the County to arrange appropriate sampling and testing after-the-fact, with certification, either by a qualified private engineer or the King County Materials Engineer. Costs of such testing and certification shall be borne by the developer. At the time that such action is directed by the Engineer, the Engineer may prohibit or limit further work on the development until all directed tests have been completed and corrections made to the satisfaction of the Engineer. If necessary, the County may take further action as set forth in King County Code Title 23, Enforcement.

9.04 Embankment Construction Control in Developments

The provisions of Section 2-03 of the WSDOT/APWA Standard Specifications apply in all respects to development construction unless otherwise instructed by the Engineer. The following elements are mentioned for clarification and emphasis:

A. Embankment and Cut Section Compaction: Compaction of the top two feet of fill subgrade and top 6 inches of cut subgrade shall meet a minimum 95% of maximum density in accordance with WSDOT/APWA Standard Specifications Section 2-03.3(14)C - Method B. Subgrade fill below the top two feet shall be compacted to 90% of maximum density.

B. Testing for Density

1. Prior to placing any surfacing material on the roadway, it will be the responsibility of the developer/contractor to provide density test reports certified by a professional engineer registered in the State of Washington. Optimum moisture content and maximum density shall be determined by methods cited in Section 2-03.3(14)D of WSDOT/APWA Standard Specifications or by other test procedures approved by the County Road Engineer. In fill sections a minimum of one test shall be taken for every 300 feet of roadway and on each lift of embankment. In cut sections the interval shall be every 200 feet of roadway. For work to be accepted tests must show consistent uniform density as required by tests referenced above.

2. In cases where tests do not meet the minimum standard, corrective action shall be taken such as adding water, aerating, replacing material or applying more compactive effort as directed by the developer's engineer. Retests shall show passing densities prior to placing the next lift of subgrade fill.

3. For trenching in existing road embankment, see Section 8.03. Backfill compaction shall be done by mechanical means.

C. Finishing Subgrade

1. At times, a small amount of additional material must be added so that the surface can be graded to final plan elevation. In such case the existing surface shall be scarified before any additional material is placed. This prevents planing and slippage between the two layers. The subgrade shall then be recompactd according to the requirements of these Standards.

2. After the subgrade preparation has been completed, it shall be thoroughly checked by the developer/contractor using a level, string line, crown board, or other means to determine that the subgrade conforms to the typical section or special plan conditions prior to placing any surfacing material.

9.05 Traffic Control in Development Construction

A. Interim Traffic Control: The developer/contractor shall be responsible for interim traffic control during construction on or along travelled County roadways. Traffic control shall follow the guidelines of Section 1-07.23 of the WSDOT/APWA Standard Specifications. All barricades, signs and flagging shall conform to the requirements of the MUTCD Manual. For more specific requirements for barricades, see Section 5.07 and Drawing No. 16. Signs must be legible and visible and should be removed at the end of each work day if not applicable after construction hours.

B. Road Closures and Detours: When road closures cannot be avoided the developer/contractor shall post "to be closed" signs a minimum of five days prior to the closing. The types and locations of the signs shall be shown on a detour plan. A detour plan must be prepared and submitted to the Department of Public Works, Traffic Planning and Engineering Section, and approved prior to closing any County roadway. In addition, the developer/contractor must notify, in writing, local fire, school, law enforcement authorities, Metro transit, and any other affected persons as directed by the Engineer at least five days prior to closing.

9.06 County Forces and County Contract Road Inspection

Road construction performed by County forces or by contract for the County will be inspected under the supervision of the Engineer.

9.07 Call Before You Dig

Builders are responsible for timely notification of utilities in advance of any construction in right-of-way or utility easements. The utility One-Call Center phone number 1-800-424-5555 should be prominently displayed on the work site.

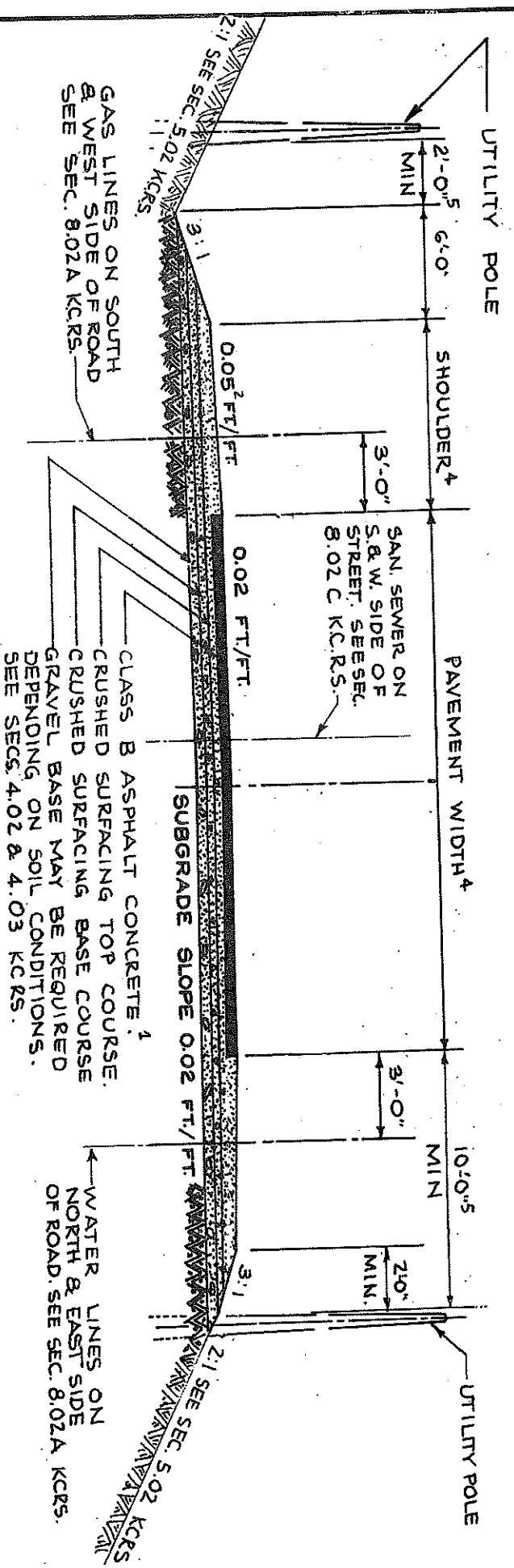

NOTES:

1. THIS DRAWING ILLUSTRATES A TYPICAL ASPHALT CONCRETE ROAD SECTION. ACTUAL SURFACING DESIGN FOR ARTERIALS AND COMMERCIAL ACCESS STREETS SHALL BE BASED ON SOILS AND TRAFFIC ANALYSES PER SEC. 4.03 K.C.R.S. DESIGN FOR RESIDENTIAL ACCESS STREETS SHALL BE PER SECS. 4.01 AND 4.02 K.C.R.S.
2. SHOULDERS SHALL BE SURFACED AS REQUIRED BY SECS. 3.07 & 4.01 K.C.R.S. IF PAVED, SHOULDER SLOPE SHALL MATCH CROWN SLOPE OR 0.02 FT./FT.
3. GRADES:
 

MINIMUM	0.5%
MAXIMUM	SEE SECS. 2.02, 2.03, 2.04, & 2.09 K.C.R.S.
4. FOR WIDTHS OF PAVEMENT, SHOULDER, AND RIGHT-OF-WAY, SEE SECS. 2.02, 2.03, & 2.04 K.C.R.S.
5. FOR CLEARANCE OF UTILITY POLES SEE SEC. 8.02G & DWG. NO. 15 K.C.R.S.

SHOULDER TYPE ROADWAY

KING COUNTY, WASHINGTON		DWG. NO. 1
----------------------------	--	---------------

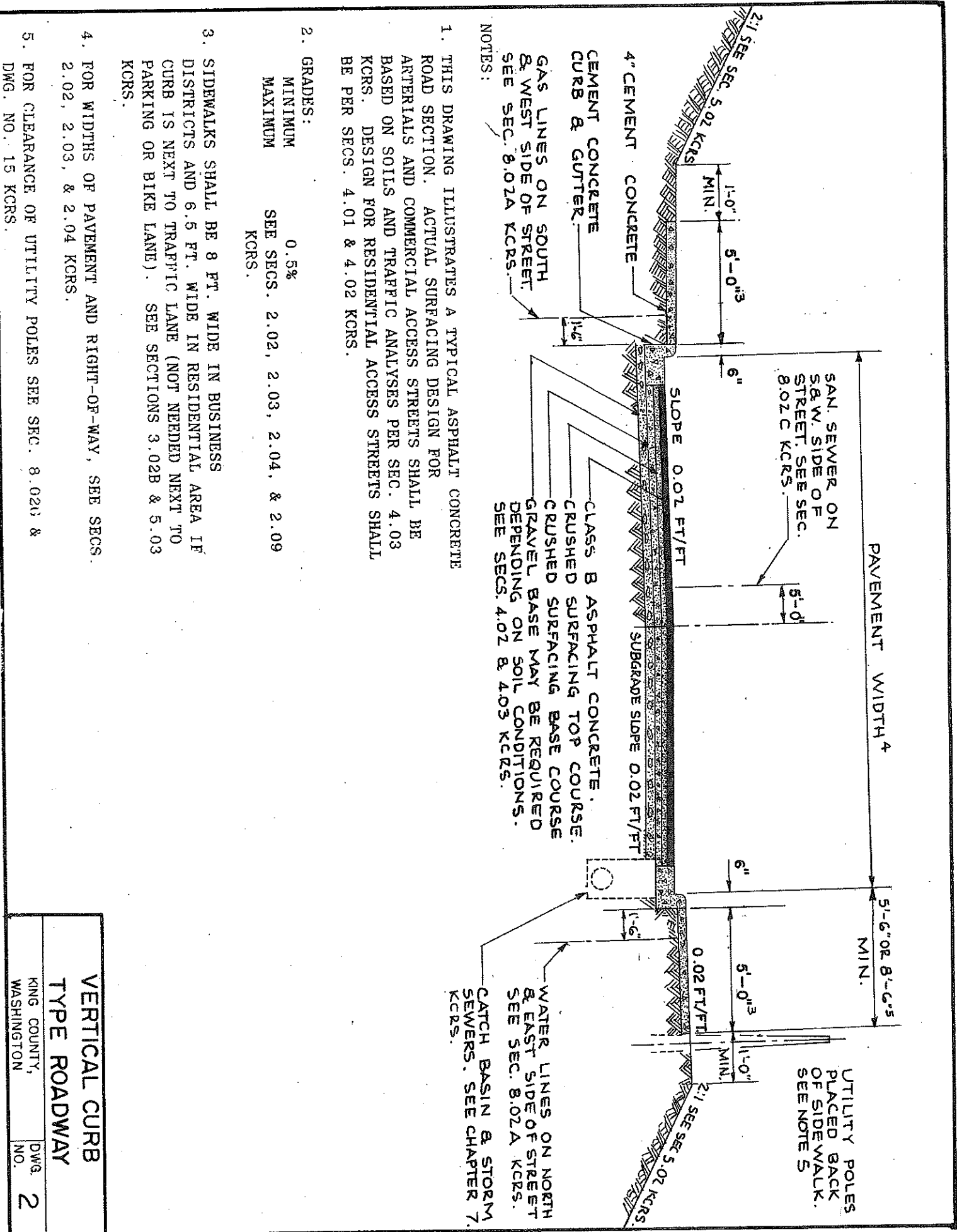

NOTES:

1. THIS DRAWING ILLUSTRATES A TYPICAL ASPHALT CONCRETE ROAD SECTION. ACTUAL SURFACING DESIGN FOR ARTERIALS AND COMMERCIAL ACCESS STREETS SHALL BE BASED ON SOILS AND TRAFFIC ANALYSES PER SEC. 4.03 KCRS. DESIGN FOR RESIDENTIAL ACCESS STREETS SHALL BE PER SECS. 4.01 & 4.02 KCRS.

2. GRADES:  
 MINIMUM 0.5%  
 MAXIMUM SEE SECS. 2.02, 2.03, 2.04, & 2.09 KCRS.

3. SIDEWALKS SHALL BE 8 FT. WIDE IN BUSINESS DISTRICTS AND 6.5 FT. WIDE IN RESIDENTIAL AREA IF CURB IS NEXT TO TRAFFIC LANE (NOT NEEDED NEXT TO PARKING OR BIKE LANE). SEE SECTIONS 3.02B & 5.03 KCRS.

4. FOR WIDTHS OF PAVEMENT AND RIGHT-OF-WAY, SEE SECS. 2.02, 2.03, & 2.04 KCRS.

5. FOR CLEARANCE OF UTILITY POLES SEE SEC. 8.02G & DWG. NO. 15 KCRS.

UTILITY POLES PLACED BACK OF SIDEWALK. SEE NOTE 5

WATER LINES ON NORTH & EAST SIDE OF STREET SEE SEC. 8.02A KCRS.  
 CATCH BASIN & STORM SEWERS. SEE CHAPTER 7. KCRS.

CLASS B ASPHALT CONCRETE.  
 CRUSHED SURFACING TOP COURSE.  
 GRAVEL BASE MAY BE REQUIRED DEPENDING ON SOIL CONDITIONS. SEE SECS. 4.02 & 4.03 KCRS.

VERTICAL CURB  
 TYPE ROADWAY

KING COUNTY,  
 WASHINGTON

DWG. NO. 2

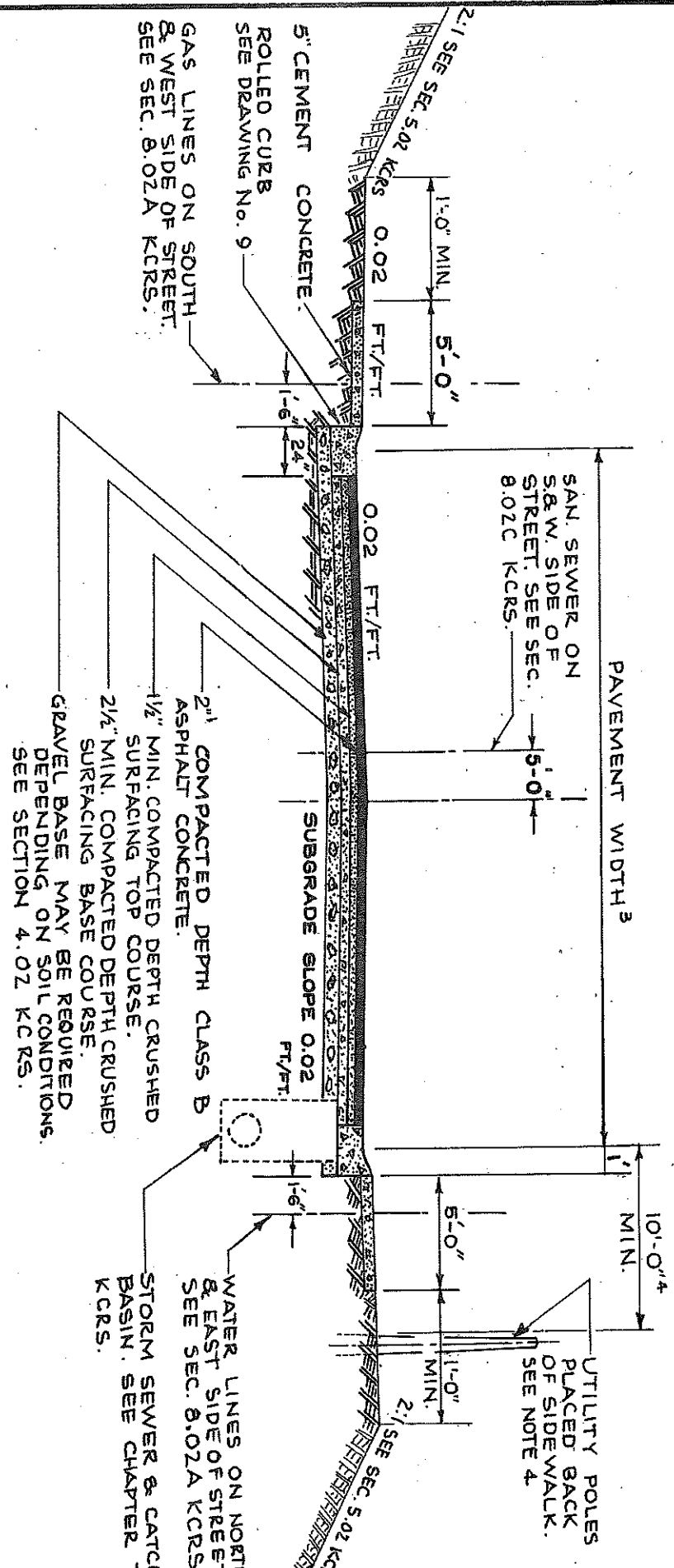

**NOTES:**

1. THIS DRAWING ILLUSTRATES A TYPICAL ASPHALT CONCRETE SECTION, ALTERNATIVE I. FOR OTHER ALTERNATIVES AND POSSIBLE REQUIREMENTS FOR INCREASED THICKNESS OF SURFACING MATERIALS, SEE SECTIONS 4.01 AND 4.02 KCRS.

2. GRADES:  
 MINIMUM 0.5%  
 MAXIMUM SEE SECS. 2.03 & 2.09 KCRS.

3. FOR WIDTHS OF PAVEMENT AND RIGHT-OF-WAY, SEE SEC. 2.03 KCRS.

4. FOR CLEARANCE OF UTILITY POLES SEE SEC. 8.02G & DWG. NO. 15 KCRS.

**ROLLED CURB  
 TYPE ROADWAY**

KING COUNTY,  
 WASHINGTON

DWG. NO. 3

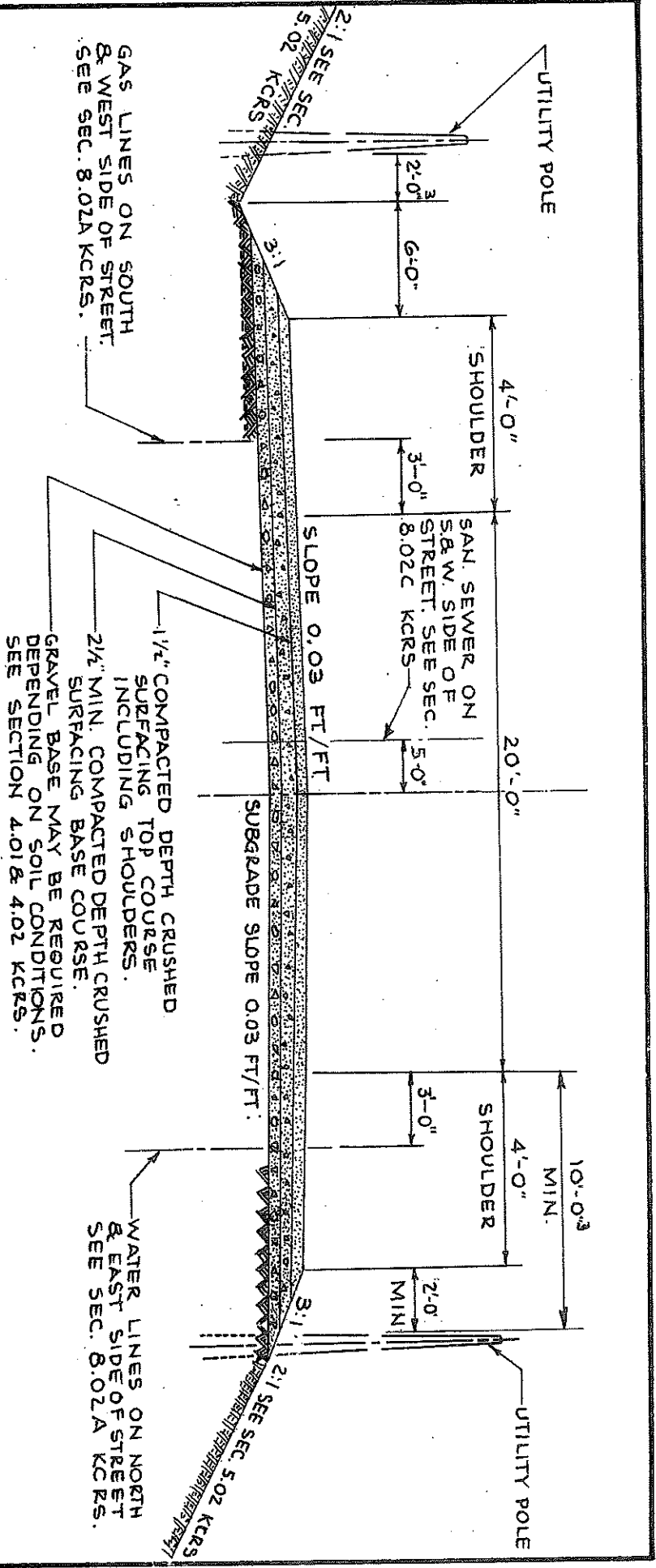

NOTES:

1. GRAVEL SURFACING IS ACCEPTABLE ONLY ON RURAL MINOR ACCESS STREETS (RESIDENTIAL) WHICH ARE PRIVATE STREETS. SEE SECTIONS 2.03 and 2.16 KCRS.

2. GRADES:

MINIMUM 0.5%  
 MAXIMUM SEE SECS. 2.03 & 2.09 KCRS.

3. FOR CLEARANCE OF UTILITY POLES SEE SEC. 8.02G & DWG. NO. 15 KCRS.

GRAVEL SURFACE ROADWAY

KING COUNTY, WASHINGTON DWG. NO. 4

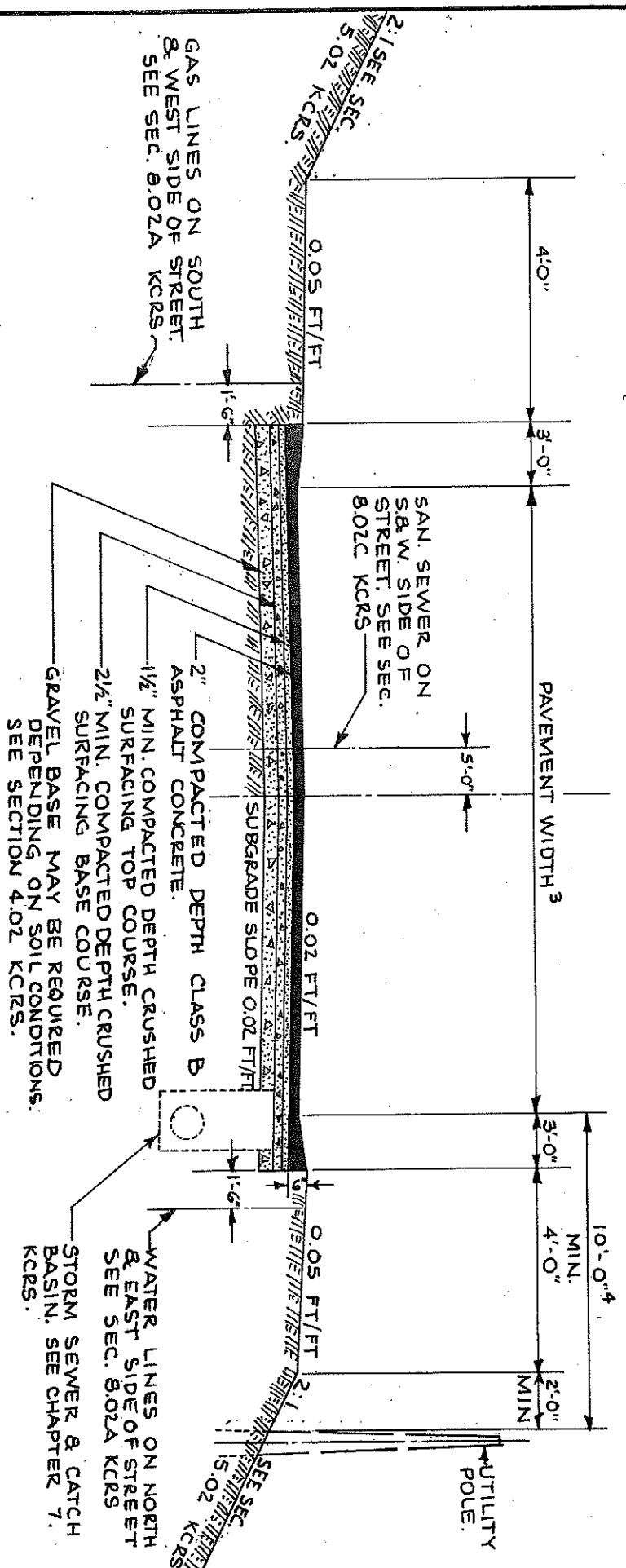

**NOTES:**

- THIS DRAWING ILLUSTRATES A TYPICAL ASPHALT CONCRETE SECTION, ALTERNATIVE I. FOR OTHER ALTERNATIVES AND POSSIBLE REQUIREMENTS FOR INCREASED THICKNESS OF SURFACING MATERIALS, SEE SECTIONS 4.01 AND 4.02 KCRS.
- GRADES:**  
 MINIMUM 0.5%  
 MAXIMUM SEE SECS. 2.03 & 2.09 KCRS.
- FOR WIDTHS OF PAVEMENT AND RIGHT-OF-WAY, SEE SECTION 2.03 KCRS.
- FOR CLEARANCE OF UTILITY POLES SEE SEC. 8.026 & DWG. NO. 15 KCRS.

**THICKENED EDGE ROADWAY**

KING COUNTY, WASHINGTON	
DWG. NO.	5

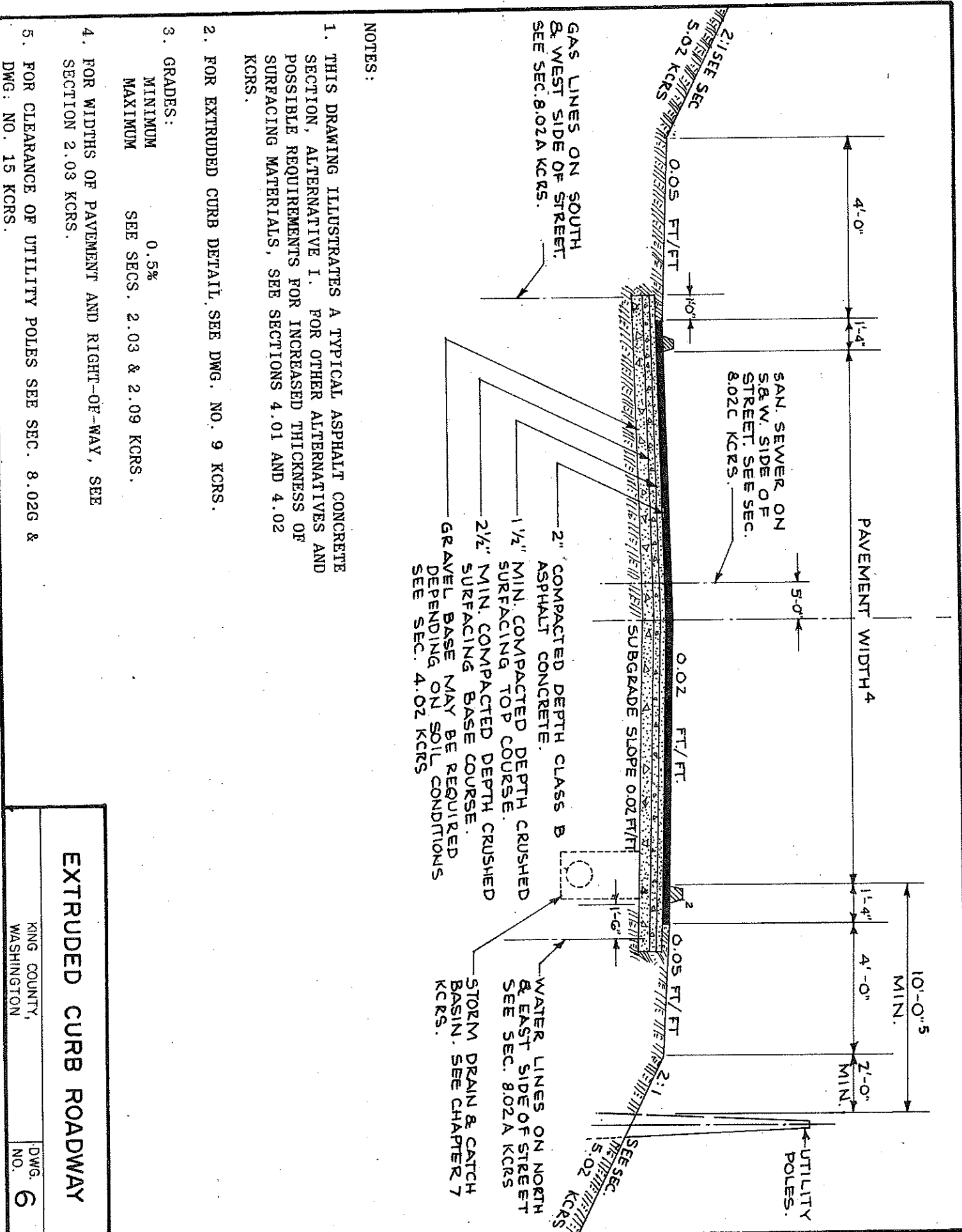

**NOTES:**

1. THIS DRAWING ILLUSTRATES A TYPICAL ASPHALT CONCRETE SECTION, ALTERNATIVE I. FOR OTHER ALTERNATIVES AND POSSIBLE REQUIREMENTS FOR INCREASED THICKNESS OF SURFACING MATERIALS, SEE SECTIONS 4.01 AND 4.02 KCRS.
2. FOR EXTRUDED CURB DETAIL, SEE DWG. NO. 9 KCRS.
3. GRADES:  
 MINIMUM 0.5%  
 MAXIMUM SEE SECS. 2.03 & 2.09 KCRS.
4. FOR WIDTHS OF PAVEMENT AND RIGHT-OF-WAY, SEE SECTION 2.03 KCRS.
5. FOR CLEARANCE OF UTILITY POLES SEE SEC. 8.02G & DWG. NO. 15 KCRS.

**EXTRUDED CURB ROADWAY**

KING COUNTY, WASHINGTON		DWG. NO. <b>6</b>
----------------------------	--	-------------------

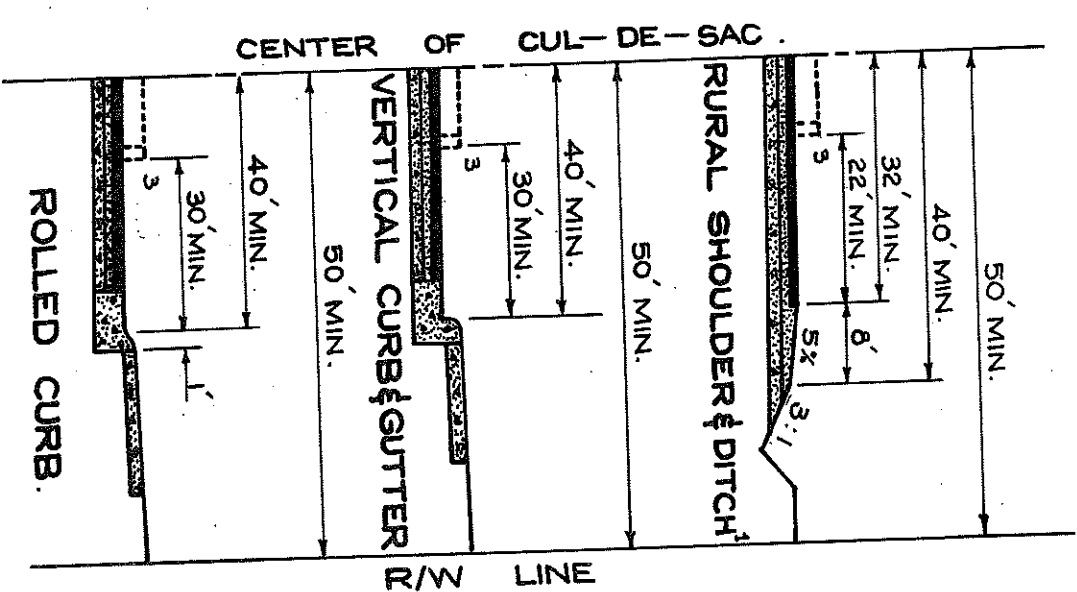
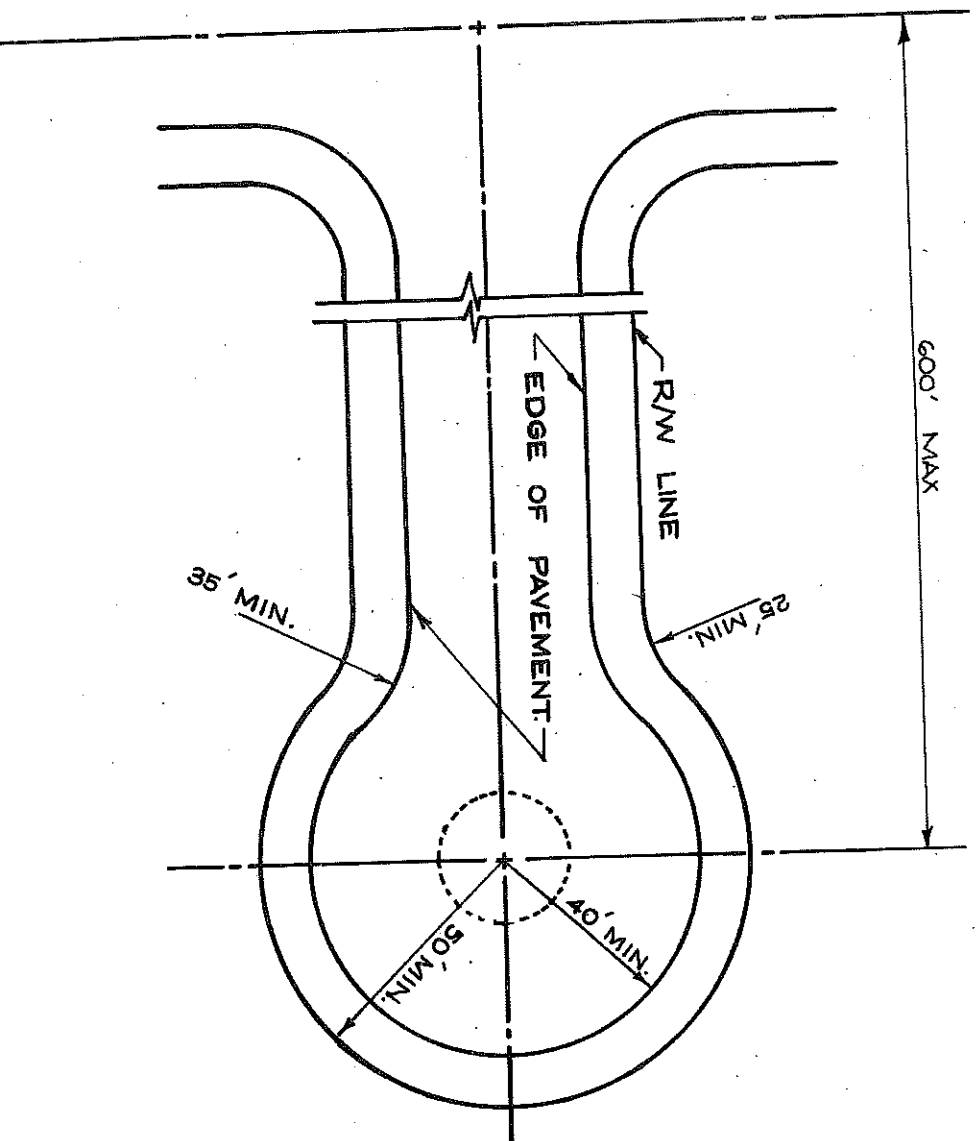

NOTES:  
 1. SEE SEC. 2.07 KCRS.

2. THICKENED EDGE AND EXTRUDED CURBS ARE ALSO ACCEPTABLE FOR OUTER EDGE AS ALTERNATIVES TO SHOULDER & DITCH. SEE DWGS 5 & 6.

3. ISLAND AT CENTER OF BULB SHALL HAVE VERTICAL CURB. SEE DRAWING NO. 9

4. ISLAND IS MANDATORY WHEN RADIUS OF PAVED AREA EXCEEDS 40'.

CUL-DE-SACS	
KING COUNTY, WASHINGTON	DWG. NO. 7

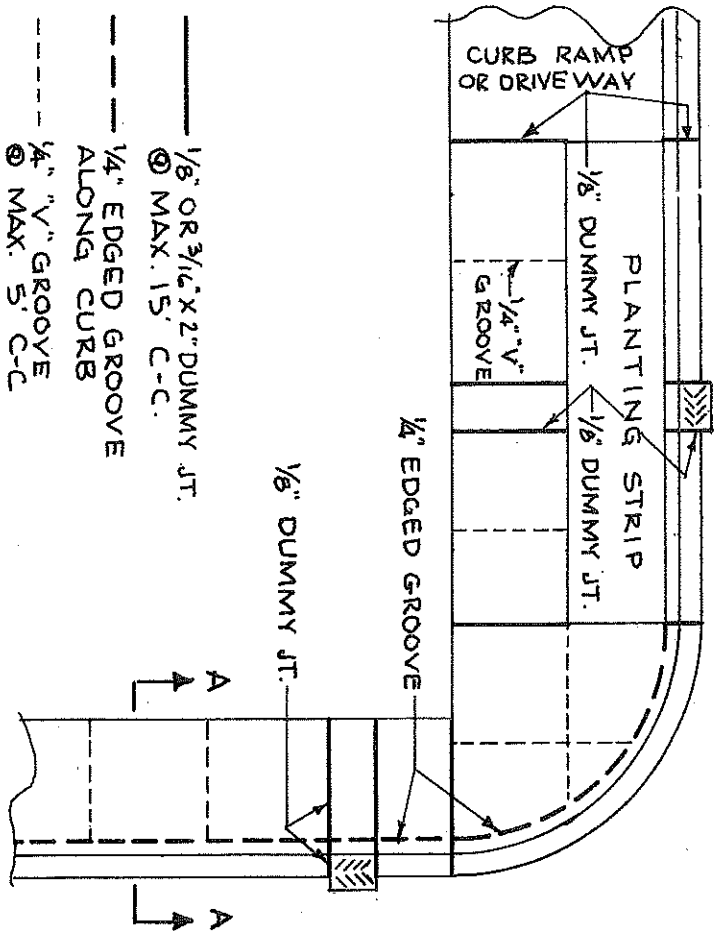
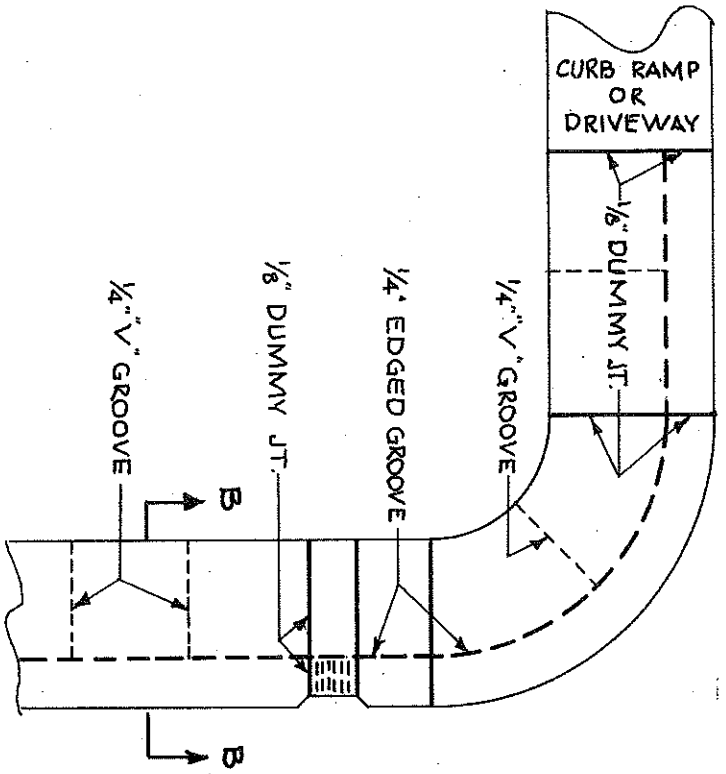

- 1/8" OR 3/16" X 2" DUMMY JT.  
⊙ MAX. 15' C-C.
- - - 1/4" EDGED GROOVE  
ALONG CURB
- - - 1/4" "V" GROOVE  
⊙ MAX. 5' C-C

**ROLLED CURB  
& SIDEWALK**

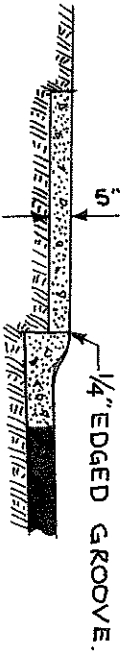

**SEC B-B**

**VERTICAL CURB  
& SIDEWALK**

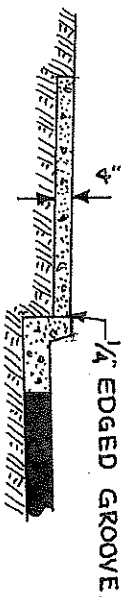

**SEC A-A**

NOTE:  
SEE SEC. 3.04 KCRS.

**CURB & SIDEWALK JOINTS**

KING COUNTY,  
WASHINGTON

DWG. NO. **8**



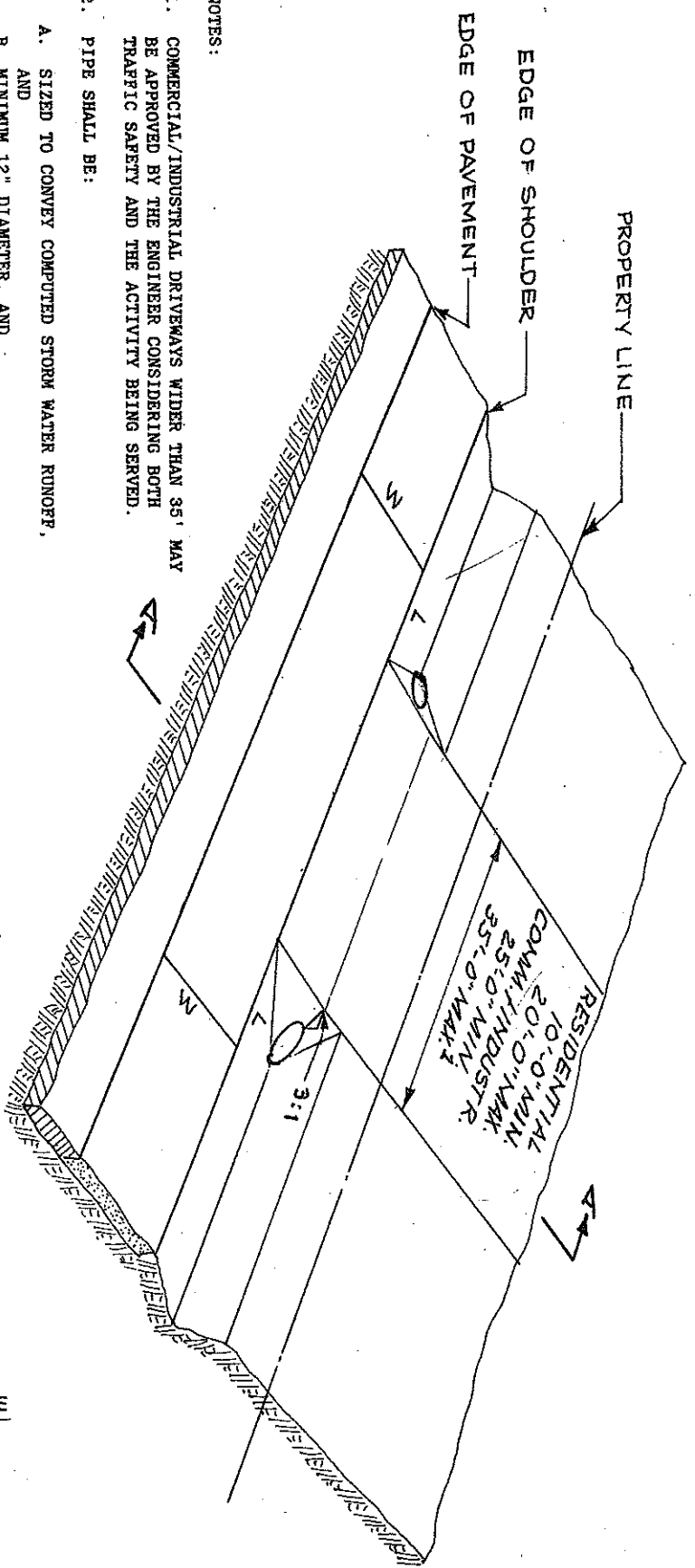

**NOTES:**

1. COMMERCIAL/INDUSTRIAL DRIVEWAYS WIDER THAN 35' MAY BE APPROVED BY THE ENGINEER CONSIDERING BOTH TRAFFIC SAFETY AND THE ACTIVITY BEING SERVED.
2. PIPE SHALL BE:
  - A. SIZED TO CONVEY COMPUTED STORM WATER RUNOFF, AND
  - B. MINIMUM 12" DIAMETER, AND
  - C. EQUAL TO OR LARGER THAN EXISTING PIPES WITHIN 500' UPSTREAM.
3. EXPOSED PIPE ENDS SHALL BE BEVELLED TO MATCH THE SLOPE FACE AND PROJECT NO MORE THAN 2" BEYOND SLOPE SURFACE. PROJECTING HEADWALLS ARE NOT ACCEPTABLE.
4. CONCRETE PIPE SHALL HAVE MINIMUM COVER OF 6" TO FINISH GRADE. ALL OTHER TYPES OF PIPE SHALL HAVE MINIMUM 12" COVER.
5. PIPE SHALL BE INSTALLED IN A STRAIGHT UNIFORM ALIGNMENT AT A MINIMUM 0.5% SLOPE (0.5 FT. PER 100 FT.) WITH THE DOWNSTREAM END LOWER THAN THE UPSTREAM END.
6. PIPE MAY BE OMITTED IF ROADSIDE DITCH DOES NOT EXIST AND DRIVEWAY DOES NOT BLOCK NATURAL FLOW.
7. DRIVEWAY SLOPE SHALL MATCH TO BACK EDGE OF SHOULDER, BUT SHOULDER SLOPE AND EDGE OF SHOULDER SHALL NOT BE ALTERED AS RESULT OF DRIVEWAY CONSTRUCTION.
8. PAVED DRIVEWAYS SHALL BE PAVED THROUGH RIGHT-OF-WAY WITH A.C. OR B.S.T. BUT NOT P.C.C.

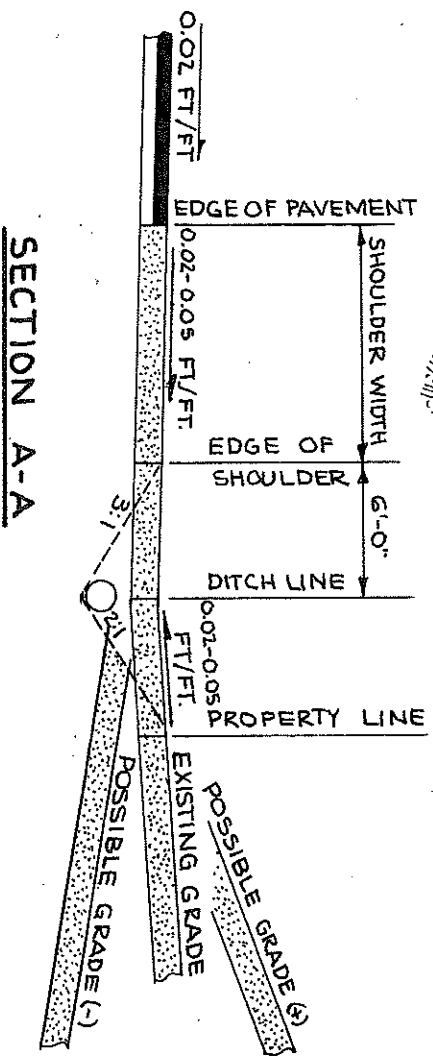

**SECTION A-A**

9. GRAVEL DRIVEWAYS SHALL HAVE SHOULDER PAVED FULL SHOULDER WIDTH BUT NOT LESS THAN 4' WITH A.C. OR B.S.T., WITH DIMENSIONS L = W.
10. SEE SECTION 3.01 KCRS.

<b>SHOULDER &amp; DITCH SECTION DRIVEWAY</b>	
KING COUNTY, WASHINGTON	DWG. NO. 10

TONGUE END ON INLET END  
GROOVE END ON OUTLET END  
ENDS TO FIT ADJACENT PIPE SECTIONS.

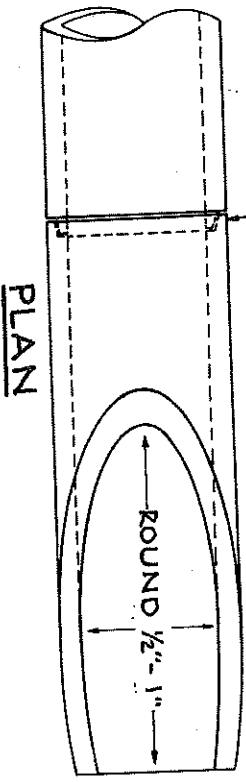

NOTE:  
FORESLOPE SHALL BE WARPED  
TO MATCH THE BEVELED PIPE  
END. WHEN CULVERT IS ON  
SKEW, BEVELED END SHALL BE  
ROTATED TO CONFORM TO SLOPE.

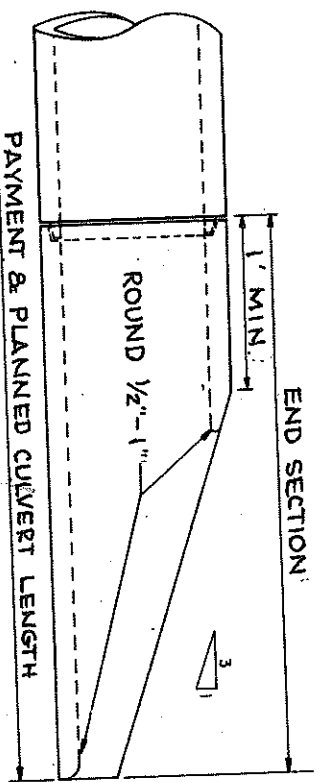

12" & 18" DIA. = 3'-5"  
24" DIA. = 5'-8"  
30" DIA. = 7'-10"

**ELEVATION**  
**CONCRETE PIPE**

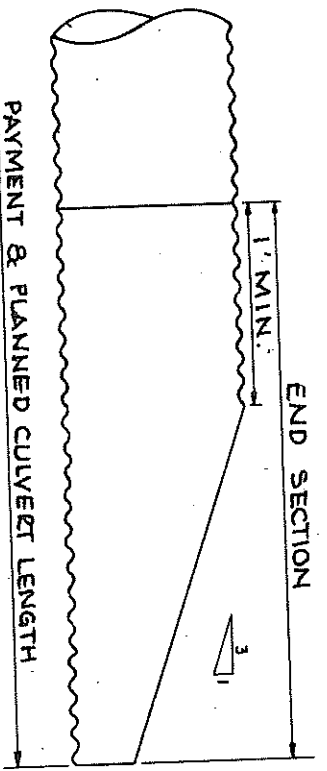

SAME AS CONCRETE PIPE

**METAL & PLASTIC PIPE**

<b>BEVELED END</b>	
<b>PIPE SECTION</b>	
KING COUNTY, WASHINGTON	DWG. NO. 11

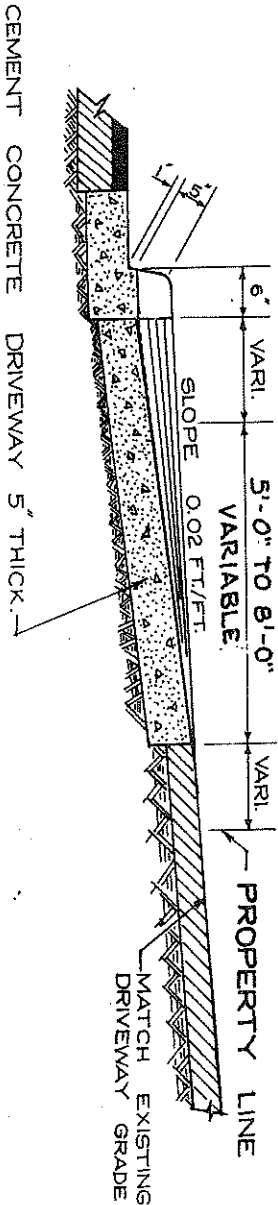
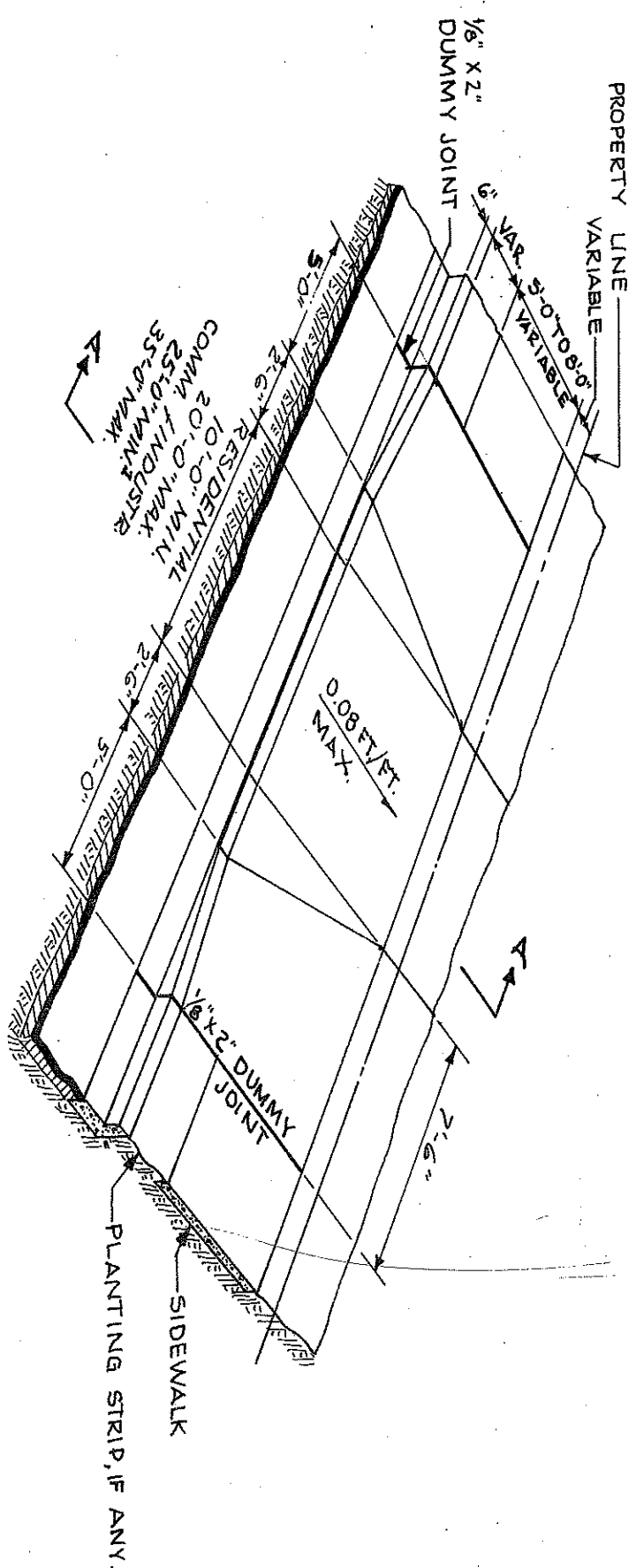

SECTION A-A

NOTES:  
 1. COMMERCIAL/INDUSTRIAL DRIVEWAYS WIDER THAN 35' MAY BE APPROVED BY THE ENGINEER CONSIDERING TRAFFIC SAFETY AND NEEDS OF THE ACTIVITY SERVED.

2. SEE SECTION 3.01 KCRS.

<b>CURB &amp; GUTTER SECTION</b>	
<b>DRIVEWAY</b>	<b>DWG. NO. 12</b>
KING COUNTY, WASHINGTON	



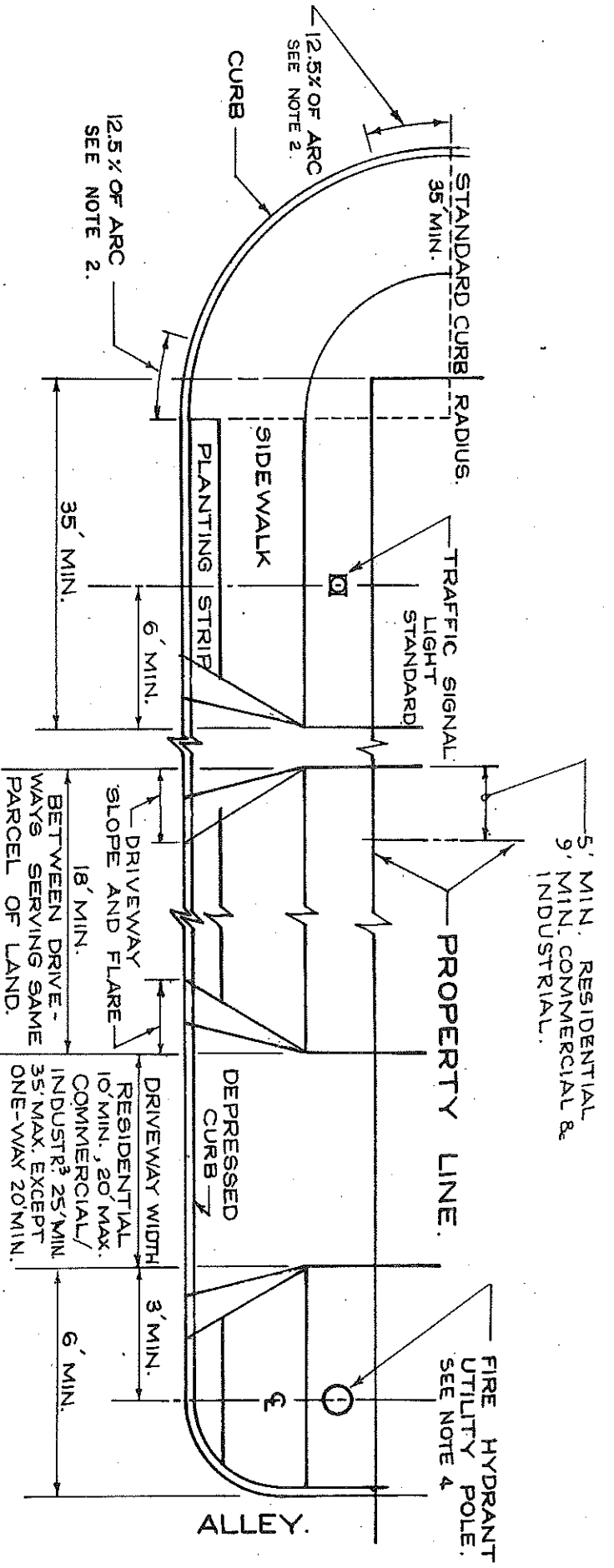

NOTES:

1. WHERE CURB RADIUS IS LESS THAN THE STANDARD 35', NO PORTION OF ANY DRIVEWAY (LESS FLARE AND SLOPE) SHALL ENCROACH IN CURB RETURN.
2. WHERE RADIUS IS 35' OR MORE, DRIVEWAY WIDTH MAY ENCRACH UPON EACH END OF CURB RETURN UP TO 12.5% OR 1/8TH OF ARC ON CURB RETURN. THIS SHOULD LEAVE AT LEAST 75% OF ARC FREE OF DRIVEWAY ENCROACHMENT (NOT COUNTING FLARED SECTION).
3. COMMERCIAL/INDUSTRIAL DRIVEWAYS WIDER THAN 35' MAY BE APPROVED BY THE ENGINEER, CONSIDERING BOTH TRAFFIC SAFETY AND THE ACTIVITY BEING SERVED.
4. FOR ROADWAY CLEARANCE OF UTILITY POLES AND STRUCTURES SEE SEC. 8.026 AND DWG. NO. 15 KCRS.

LOCATION AND WIDTH OF NEW DRIVEWAYS

KING COUNTY, WASHINGTON DWG. NO. 14

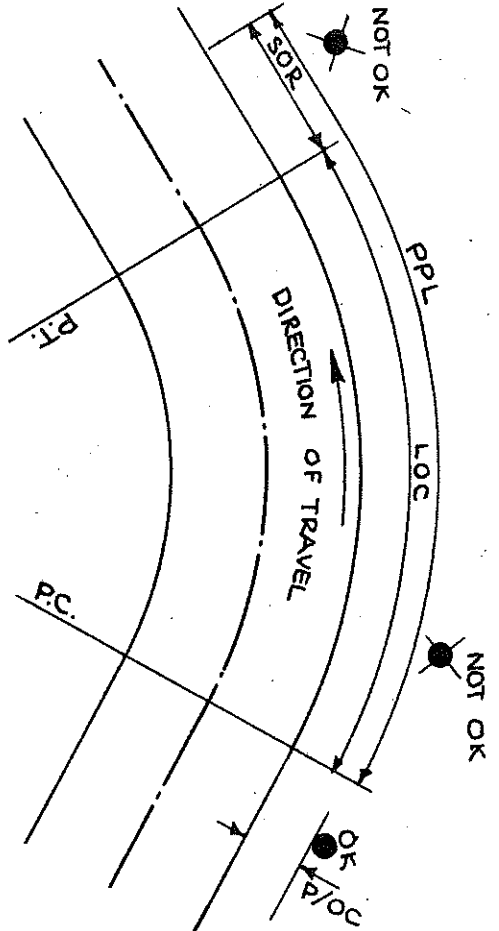

**OUTSIDE OF CURVE**  
**40 MPH & OVER**

LOC: LENGTH OF CURVE (FEET) AT EDGE OF TRAVELED WAY FROM P.C. TO PT.

SOR: SAFETY OVERRUN (FEET) BEYOND PT.

PPL: PROHIBITED POLE LOCATION (FEET) (LOC + SOR) WHERE POLES OR OBSTACLES MUST BE REMOVED OR BARRICADED.

PPL (FEET) ON OUTSIDE OF CURVES WITH POSTED SPEEDS 40 MPH & OVER	
40 MPH	LOC + 220 (SOR)
45	LOC + 255
50	LOC + 290
55	LOC + 325

APPLIES TO ROADWAY WITH SHOULDER OR MOUNTABLE CURB ON OUTSIDE OF CURVE WITH:  
 ° RADIUS ≤ 3500' AND  
 ° POSTED SPEED ≥ 40 MPH.

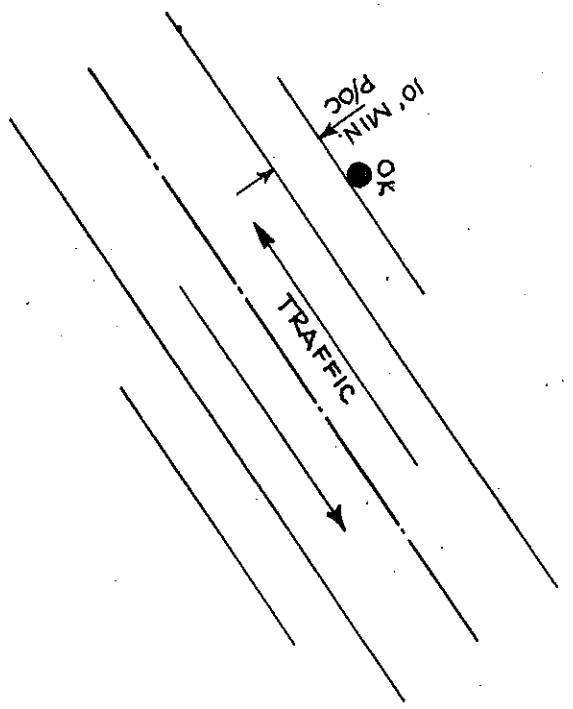

**GENERAL CASE**

P/O.C: POLE/OBSTACLE CLEARANCE TO NEAREST FACE OF POLE/OBSTACLE.

APPLIES: TO ROADWAY WITH SHOULDER, OR MOUNTABLE CURB ON:

1. TANGENT, OR
2. INSIDE OF CURB, OR
3. OUTSIDE OF CURVE, EITHER WITH  
 ° POSTED SPEED < 40 MPH OR  
 ° RADIUS > 3500' ON ROADWAY  
 MEETING ALL CURRENT DESIGN STANDARDS.

- NOTES:
1. DEVIATION FROM THIS CHART MAY BE ALLOWED WHEN JUSTIFIED BY SUITABLE ENGINEERING STUDY CONSIDERING TRAFFIC SAFETY.
  2. SEE SECTIONS 5.11 & B.02g.

**CLEARANCE OF ROADSIDE OBSTACLES ON SHOULDER TYPE ROAD**

KING COUNTY  
 WASHINGTON

DWG. NO. 15

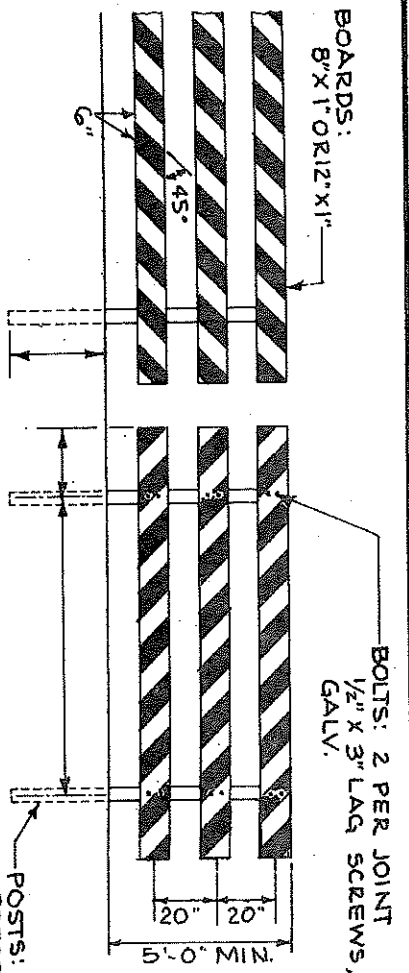

FIXED (PERMANENT)  
TYPE III BARRICADE

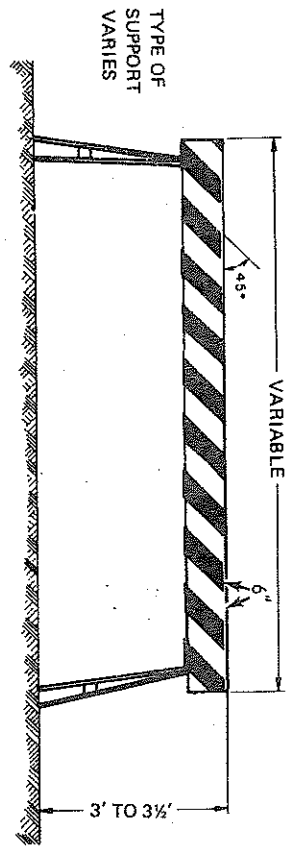

TYPE I BARRICADE

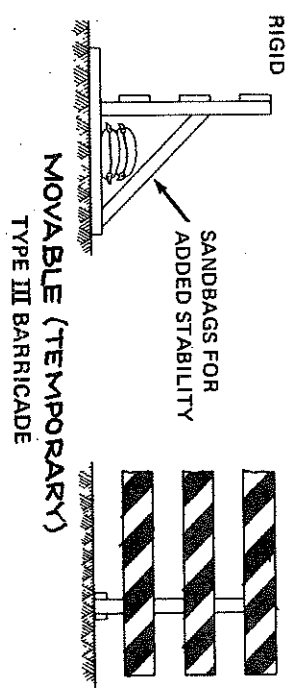

MOVABLE (TEMPORARY)  
TYPE III BARRICADE

NOTE:  
FOR DIMENSIONS NOT  
SHOWN, SEE TABLE.

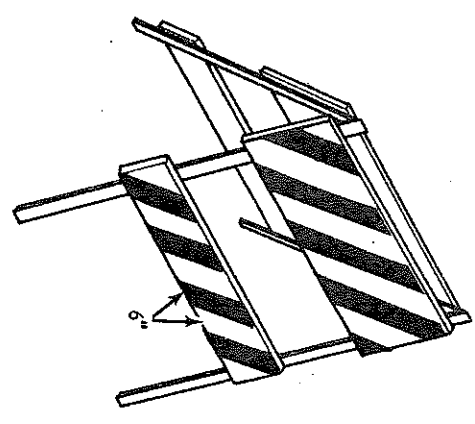

TYPE II BARRICADE

BARRICADE NOTES:

TYPE	I	II	III
WIDTH OF RAIL	8" MIN 12" MAX	8" MIN 12" MAX	8" MIN 12" MAX
LENGTH OF RAIL	2' MIN	2' MIN	4' MIN
HEIGHT	3' MIN	3' MIN	5' MIN
TYPE OF FRAME	DEMOUNTABLE OR HEAVY "A" FRAME	LIGHT "A" FRAME	POST OR SKIDS
FLEXIBILITY	ESSENTIALLY MOVABLE	PORTABLE	ESSENTIALLY PERMANENT

STRIPES NOTES:

ORANGE & WHITE IF TEMPORARY.  
RED & WHITE IF PERMANENT.  
REFLECTORIZED  
SLANT DOWNWARD, RIGHT OR LEFT, IN DIRECTION TRAFFIC  
WILL PASS.  
SLANT BOTH DIRECTIONS FROM MIDDLE IF TRAFFIC PASSES  
BOTH ENDS.  
WIDTH 6" EXCEPT 3" IF RAILS ARE LESS THAN 3' LONG.  
SEE SECTION 5.07 KCRS AND MUTCD SECTION 6C-8.

TYPE OF FRAME	DEMOUNTABLE OR HEAVY "A" FRAME	LIGHT "A" FRAME	POST OR SKIDS
FLEXIBILITY	ESSENTIALLY MOVABLE	PORTABLE	ESSENTIALLY PERMANENT

**BARRICADES**  
KING COUNTY, DWG. NO. 16  
WASHINGTON

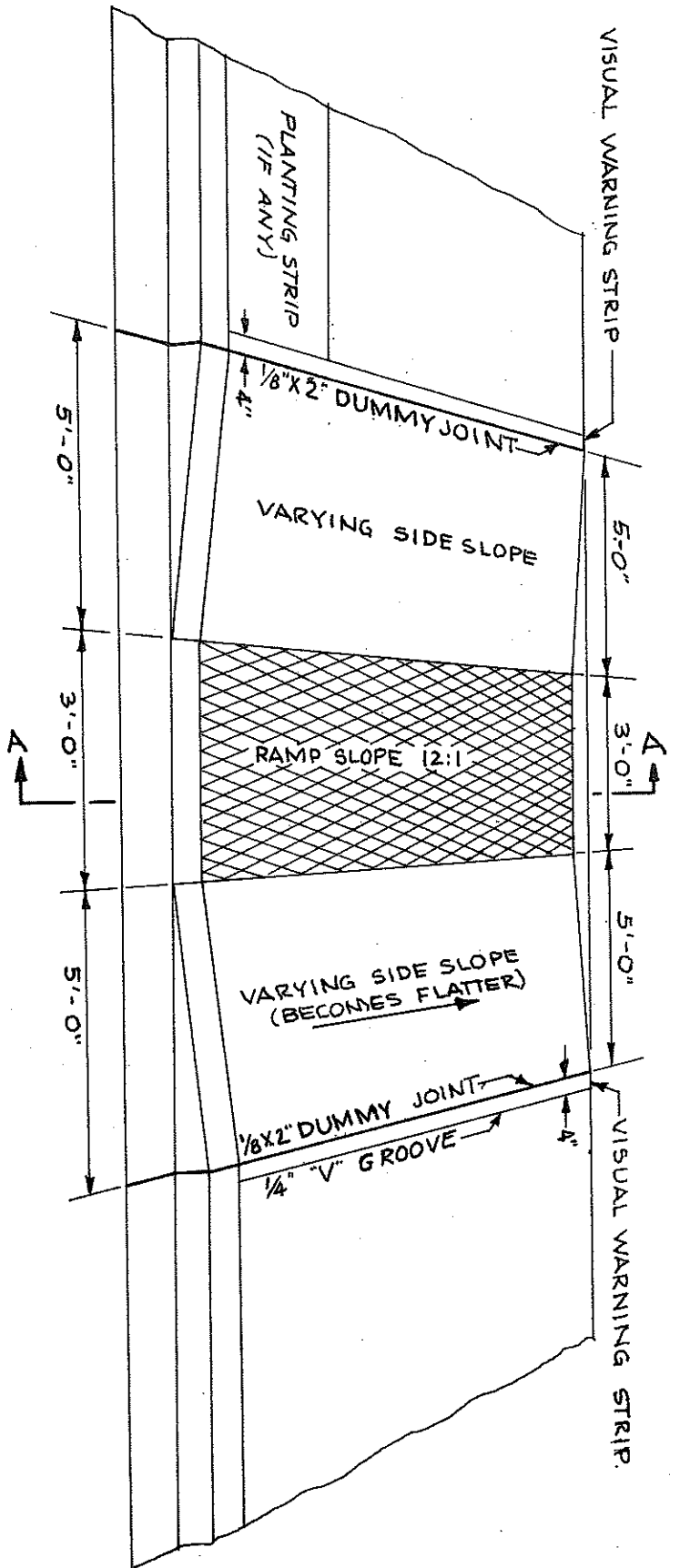

- NOTES:
1. RAMP AND APPROACHES SHALL BE CLEAR OF OBSTACLES INCL. HYDRANTS, POLES & INLETS.
  2. RAMP SHALL BE TEXTURED BY IMPRINT OF METAL GRID WITH 1/2" SPACING.
  3. VISUAL WARNING STRIP SHALL BE PROVIDED 4" WIDE BETWEEN EXPANSION AND SCORED (CONTRACTION) JOINTS.
  4. RAMP CENTER LINE SHALL BE PERPENDICULAR TO OR RADIAL TO CURB RETURNS UNLESS OTHERWISE APPROVED BY ENGINEER.
  5. WHEN RAMPS ARE CONSTRUCTED ON ONE SIDE OF STREET, RAMPS SHALL BE CONSTRUCTED AT CORRESPONDING SIDEWALK LOCATIONS ON OPPOSITE SIDE OF STREET.
  6. ON ARTERIAL STREETS, IN GENERAL CASE, CURB RAMPS SHALL BE CONSTRUCTED TWO PER RADIUS, IN OR PREFERABLY ADJACENT TO THE MAIN PEDESTRIAN PATHS.
  7. ON RESIDENTIAL STREETS AND/OR WHEN UTILITIES ARE IN CONFLICT OR STREET GRADE EXCEEDS 4.0% CURB RAMPS MAY BE CONSTRUCTED ONE PER RADIUS, AT MIDDLE POINT OF CURB RETURN OR AT MAIN PEDESTRIAN PATH.
  8. SEE SEC. 3.05 K.C.R.S.

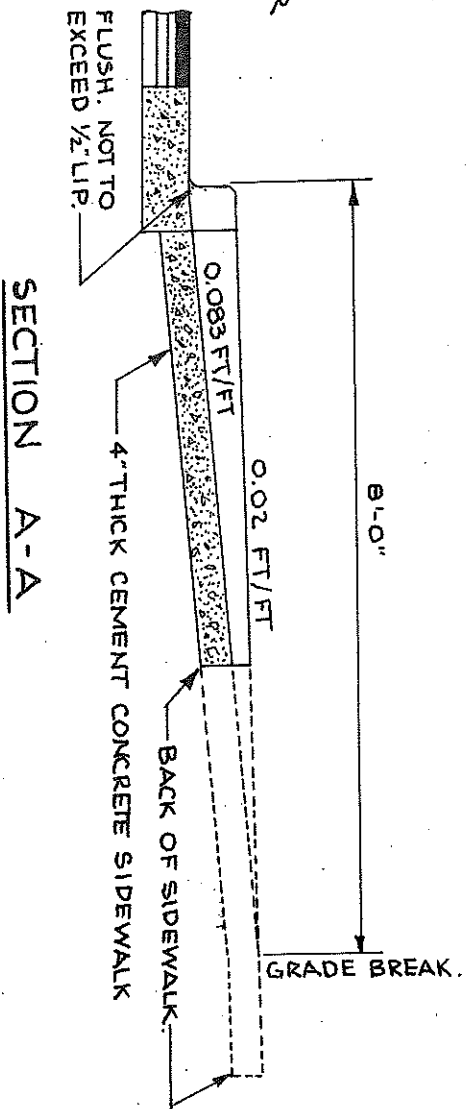

**CURB RAMPS  
IN VERTICAL CURB**

KING COUNTY,  
WASHINGTON

DWG. NO. 17

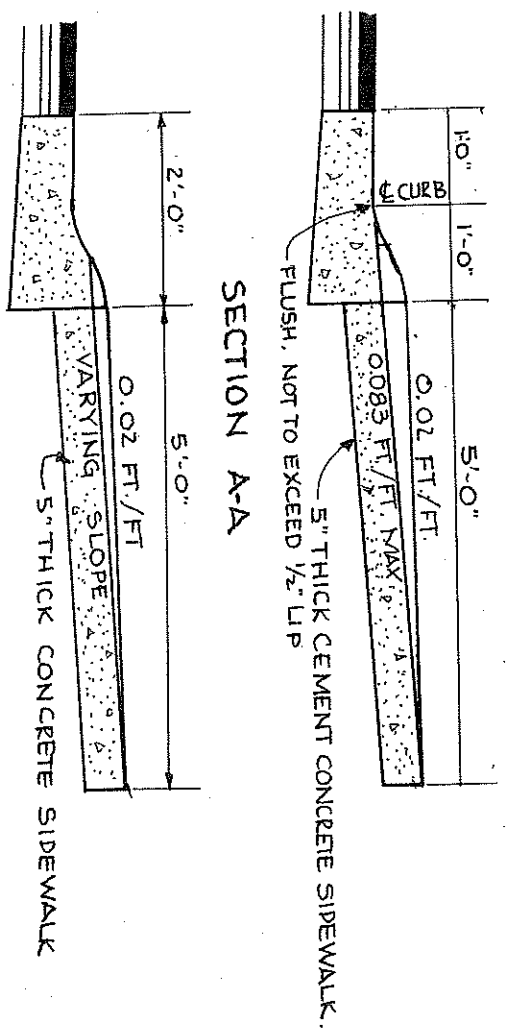
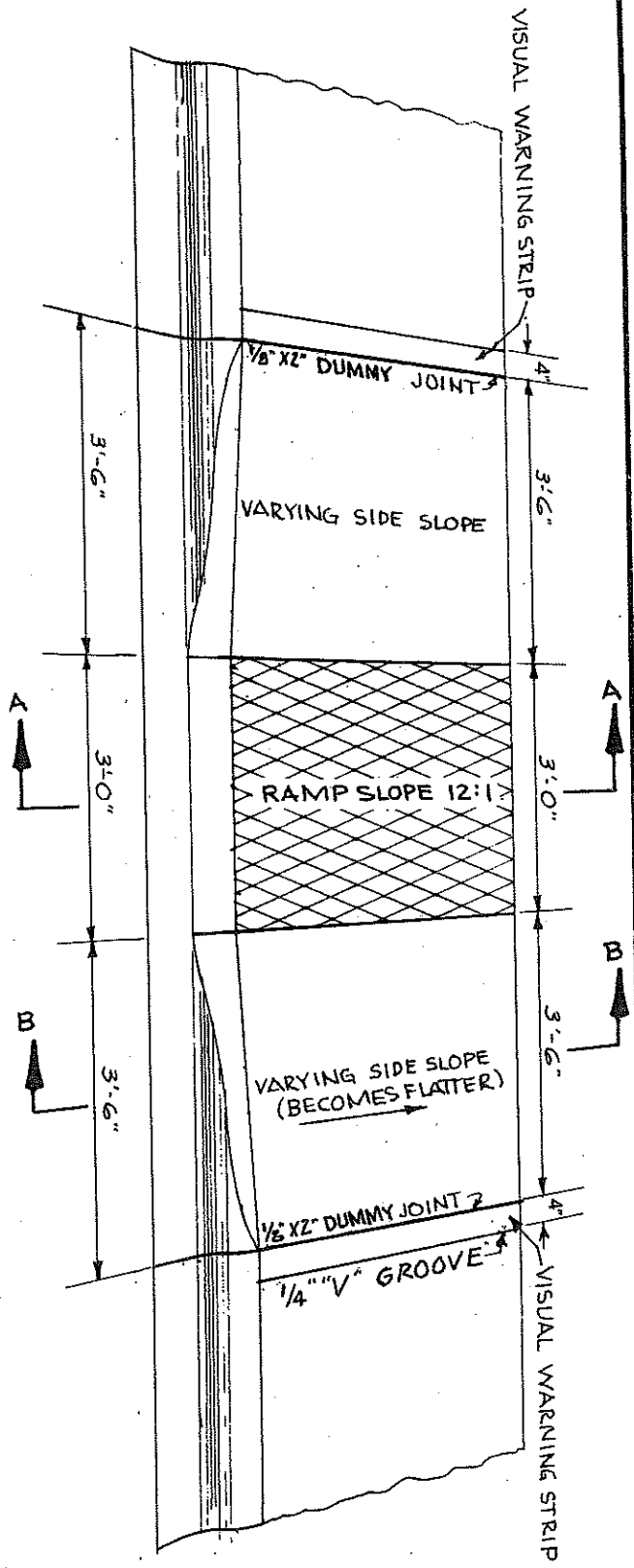

- NOTES:
1. RAMP AND APPROACHES SHALL BE CLEAR OF OBSTACLES INCL. HYDRANTS, POLES & INLETS.
  2. RAMP SHALL BE TEXTURED BY IMPRINT OF METAL GRID WITH 1/2" SPACING.
  3. VISUAL WARNING STRIP SHALL BE PROVIDED 4" WIDE BETWEEN EXPANSION AND SCORED (CONTRACTION) JOINTS.
  4. RAMP CENTER LINE SHALL BE PERPENDICULAR TO OR RADIAL TO CURB RETURNS UNLESS OTHERWISE APPROVED BY ENGINEER.
  5. WHEN RAMPS ARE CONSTRUCTED ON ONE SIDE OF STREET, RAMPS SHALL BE CONSTRUCTED AT CORRESPONDING SIDEWALK LOCATIONS ON OPPOSITE SIDE OF STREET.
  6. ON ARTERIAL STREETS, IN GENERAL CASE, CURB RAMPS SHALL BE CONSTRUCTED TWO PER RADIUS, IN OR PREFERABLY ADJACENT TO THE MAIN PEDESTRIAN PATHS.
  7. ON RESIDENTIAL STREETS AND/OR WHEN UTILITIES ARE IN CONFLICT OR STREET GRADE EXCEEDS 4.0% CURB RAMPS MAY BE CONSTRUCTED ONE PER RADIUS, AT MIDPOINT OF CURB RETURN OR AT MAIN PEDESTRIAN PATH.

8. SEE SEC. 3.05 K.C.R.S.

<b>CURB RAMPS IN ROLLED CURB</b>	
KING COUNTY, WASHINGTON	DWG. NO. 18

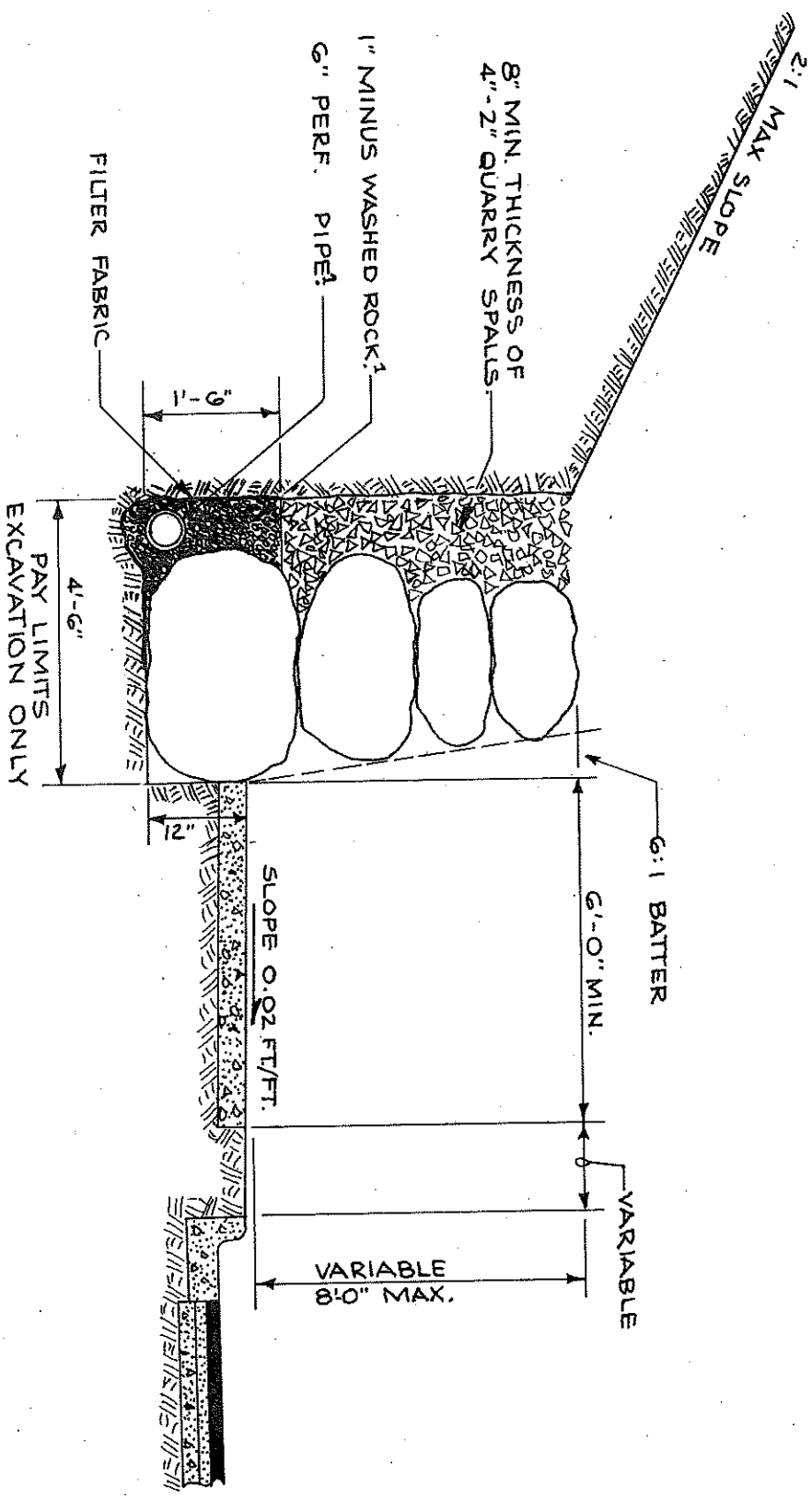

**NOTE:**

1. PERF. PIPE WITH WASHED ROCK AS NEEDED FOR SUBSURFACE WATER.
2. SEE SEC. 5.01. KCRS.

**ROCK FACING, CUT SECTION**

KING COUNTY,  
WASHINGTON

DWG. NO. **19**

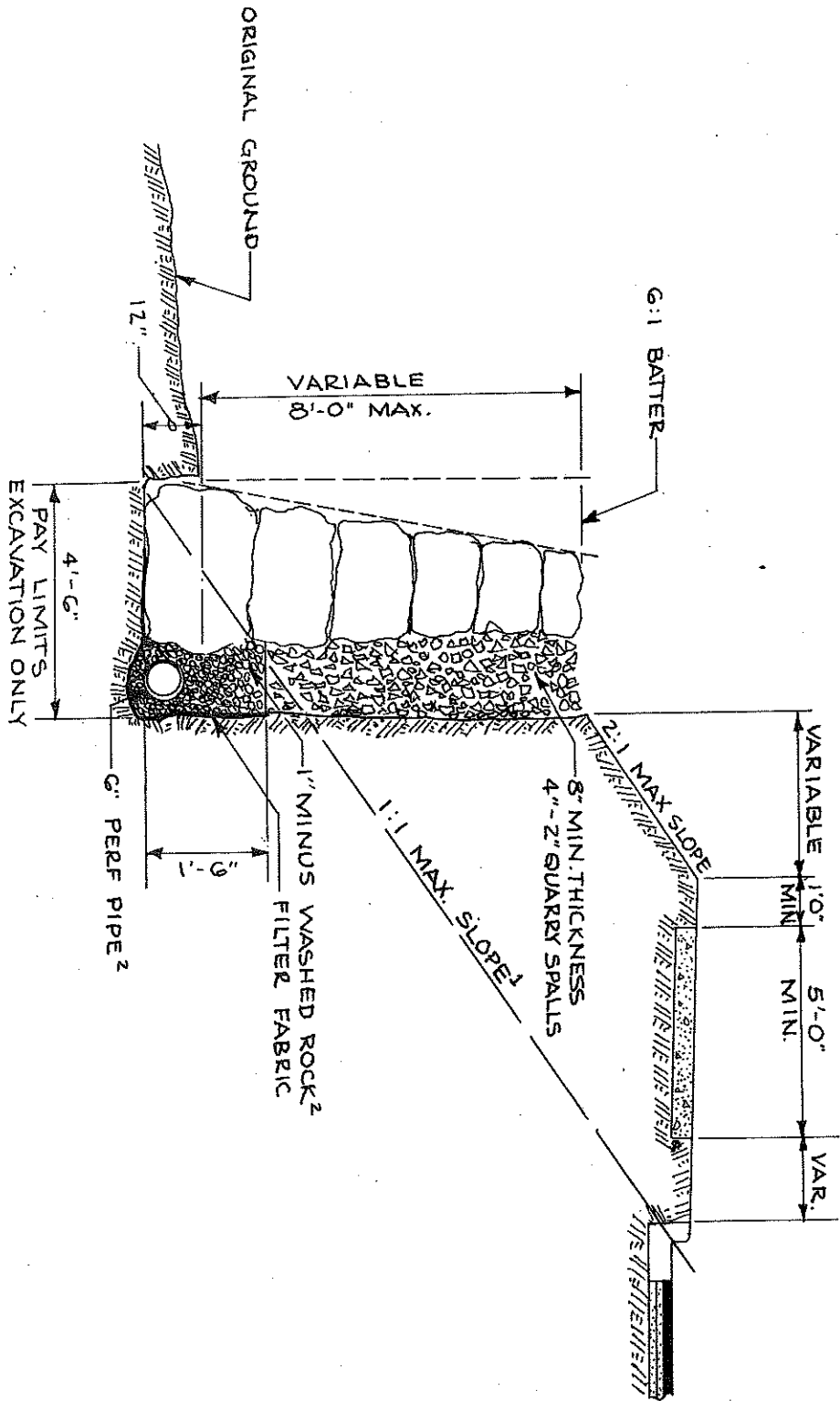

NOTE:

1. FLATTER SLOPE MAY BE REQUIRED IN LESS STABLE SOILS.
2. PERFORATED PIPE AS NEEDED FOR SUBSURFACE WATER.
3. SEE SEC. 5.01.KCRS.

ROCK FACING, FILL SECTION

KING COUNTY,  
WASHINGTON

DWG. NO. 20

- NOTES:
1. FLATTER SLOPE MAY BE REQUIRED IN LESS STABLE SOILS.
  2. PERF. PIPE AS NEEDED FOR SUBSURFACE WATER.
  3. INSTALL CHAIN LINK FENCE TYPE NO. G, TYPE NO. G, AS REQUIRED, OR METAL HANDRAIL AS ALTERNATE. FENCE OR HANDRAIL REQUIRED WHEN ROCKERY IS 3' OR MORE IN HEIGHT.
  4. DEPTH OF CAP TO TOP OF ROCKS IS 6'-1" WITH NO FENCE, 6" MIN. WITH FENCE.
  5. SEE SEC. 5.01. KCRS.

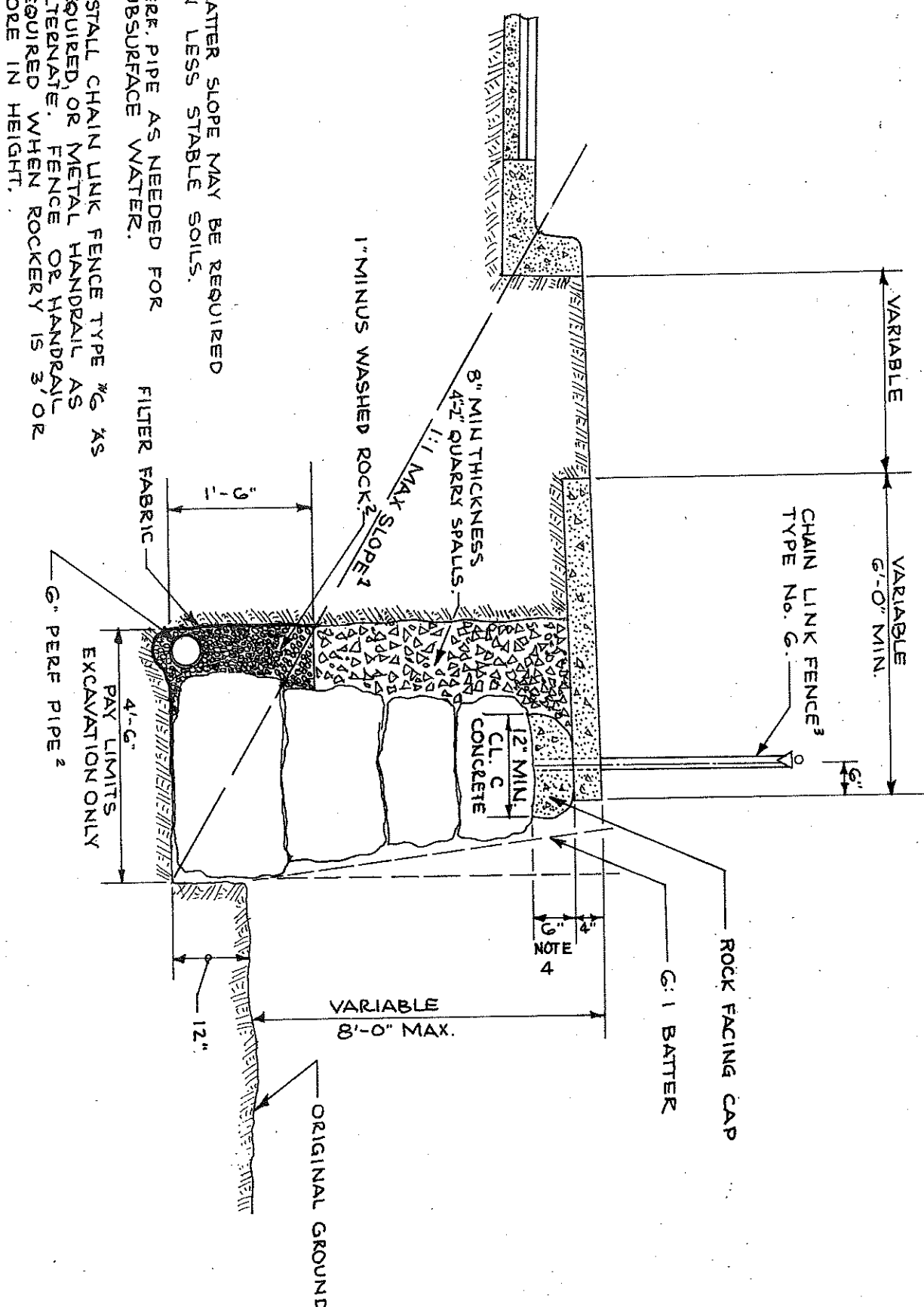

**ROCK FACING UNDER SIDEWALK**

KING COUNTY,  
WASHINGTON

DWG. NO. 21

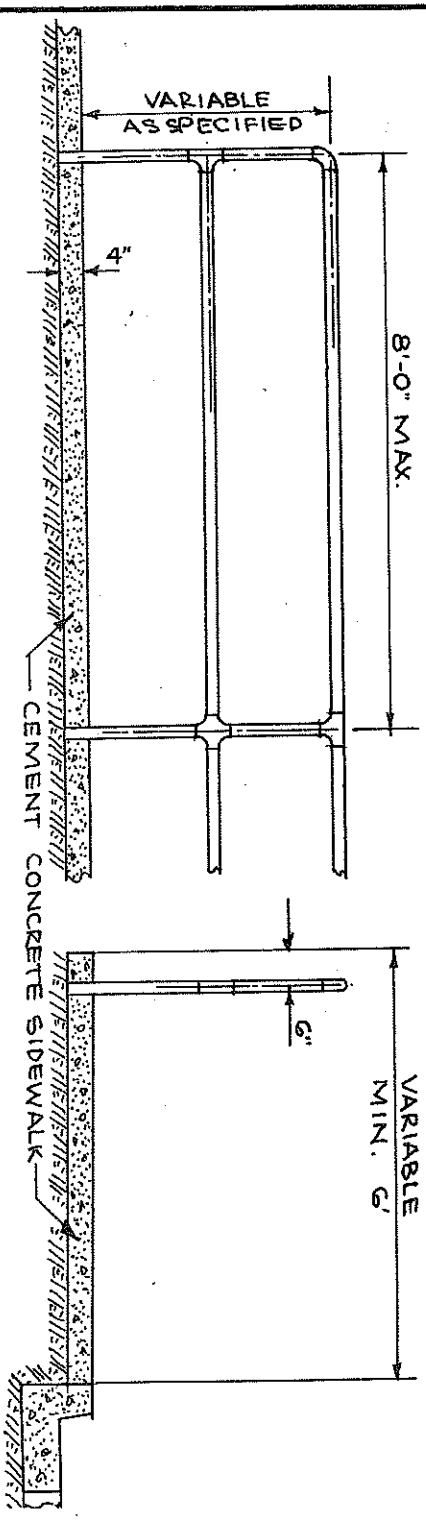
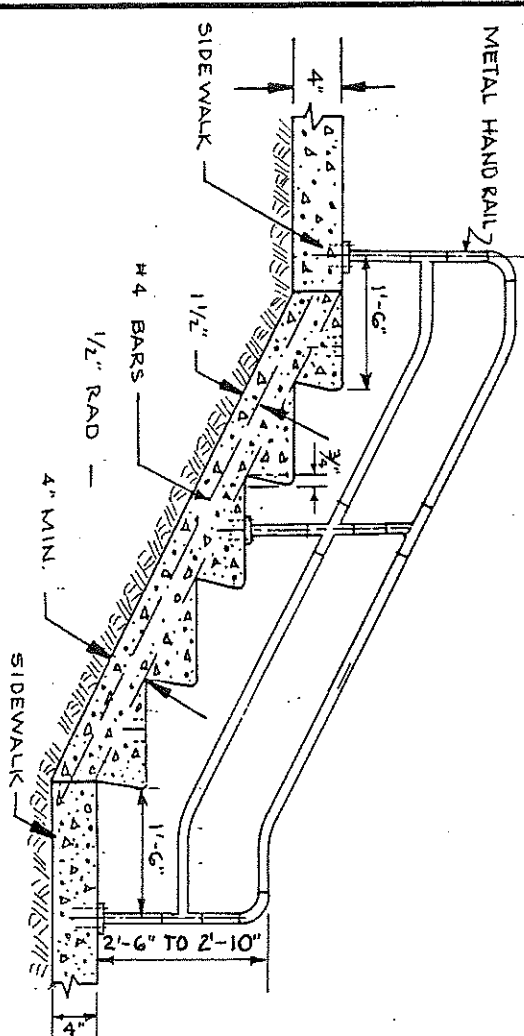
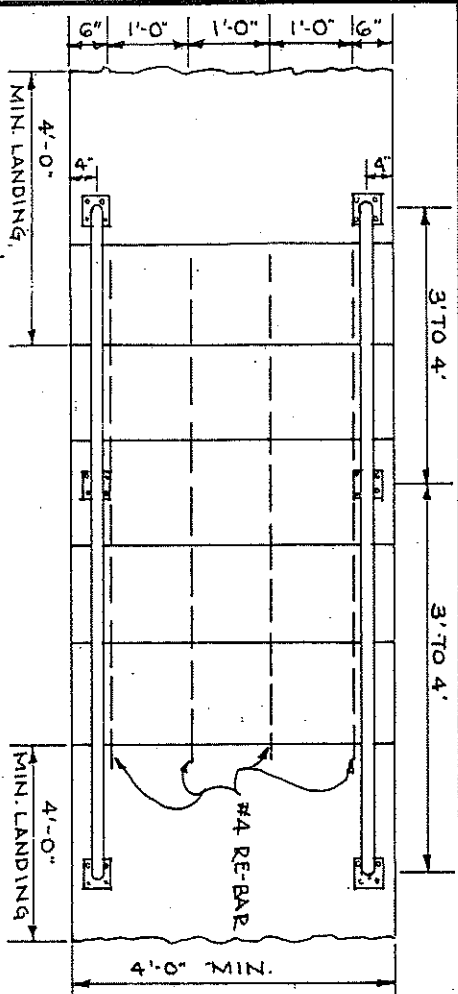

NOTES FOR CONCRETE STEPS.

1. CONCRETE: CEMENT CONCRETE CLASS B.
2. ALL STEPS: SAME DIMENSIONS, WITHIN 3/8" MAX. DIFFERENCE.
3. RISERS: 7 1/2" MAX., 5" MIN.
4. TREADS: 12" MAX., 11" MIN., WITH TRANSVERSE 0.01 FT/FT SLOPE.
5. METAL HANDRAIL REQUIRED FOR 4 STEPS OR MORE. SEE NOTES BELOW.
6. REINFORCING BARS, # 4 SIZE GRADE 40 @ 1'-0" SPACING, REQUIRED FOR 4 STEPS OR MORE.
7. SEE SEC. 3.06 KCRS.

NOTES FOR HANDRAILS,

1. GALVANIZED STEEL OR ALUMINUM.
2. 1 1/4" TO 2" O.D. ROUND OR OVAL PIPE.
3. WELDED, WITH SMOOTH SURFACE AND JOINTS.
4. POSTS SET IN MIN. 4" CONCRETE.
5. SEE SEC. 3.06 KCRS.

**CONCRETE STEPS  
8. METAL HANDRAIL**

KING COUNTY  
WASHINGTON

DWG. NO. **22**

FIRE HYDRANT OR UTILITY POLE

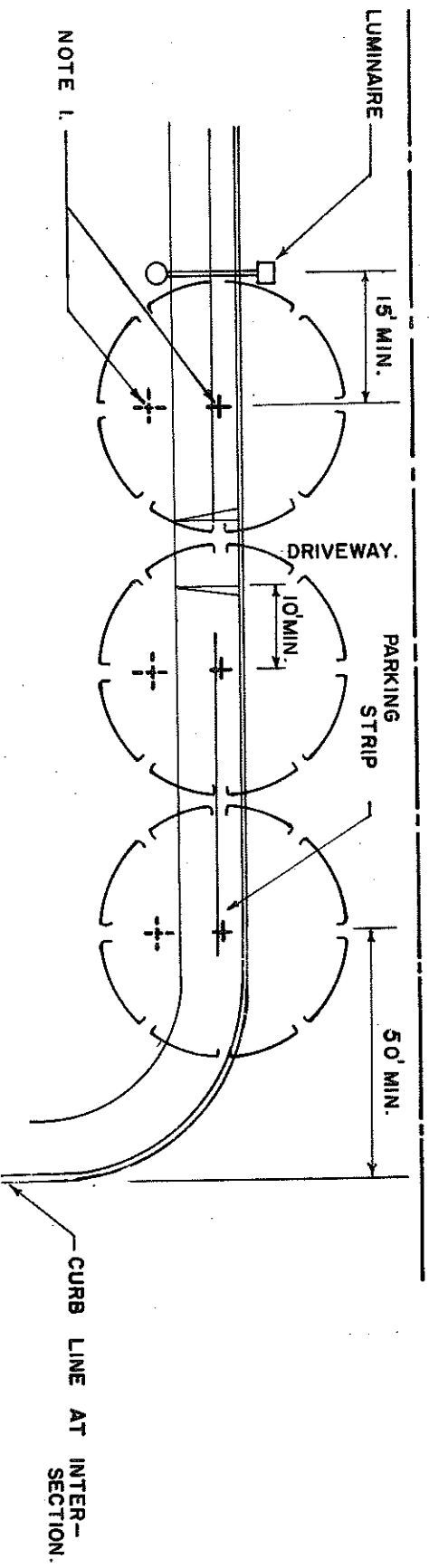
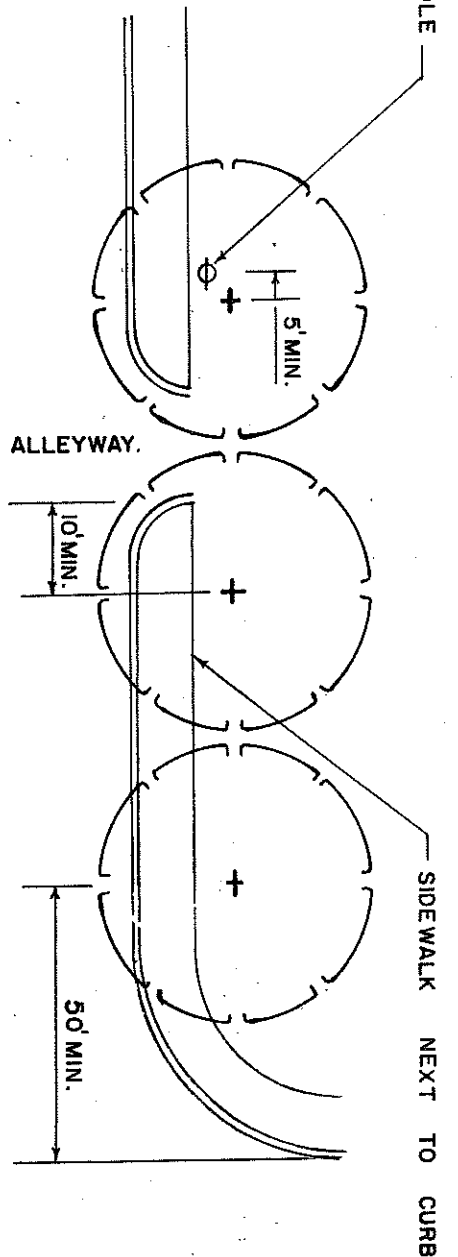

NOTES:

1. TREES SHALL GENERALLY BE PLANTED BACK OF THE SIDEWALK. PLANTING STRIPS WILL BE APPROVED ONLY AS PART OF A LANDSCAPING PLAN IN WHICH PLANT MAINTENANCE, COMPATIBILITY WITH UTILITIES, AND TRAFFIC SAFETY ARE DULY CONSIDERED.

2. IF PLANTING STRIPS ARE APPROVED:

A. MIN. DISTANCE FROM CENTER OF ANY TREE TO NEAREST EDGE OF CURB SHALL BE 4 FEET.

B. TREES SHALL BE STAKED IN A MANNER NOT TO OBSTRUCT SIDEWALK TRAFFIC.

C. IN CASE OF BLOCK-OUTS, MIN. CLEAR SIDEWALK WIDTH SHALL BE 5 FEET IN RESIDENTIAL OR 8 FEET IN BUSINESS DISTRICTS.

3. ON BUS ROUTES, PLANS SHALL BE COORDINATED WITH METRO, PHONE 447-6319.

4. SEE SECTION 5.03 KCORS.

CURB LINE AT INTERSECTION.

**STREET TREE STANDARDS**

KING COUNTY, WASHINGTON DWG. NO. 23

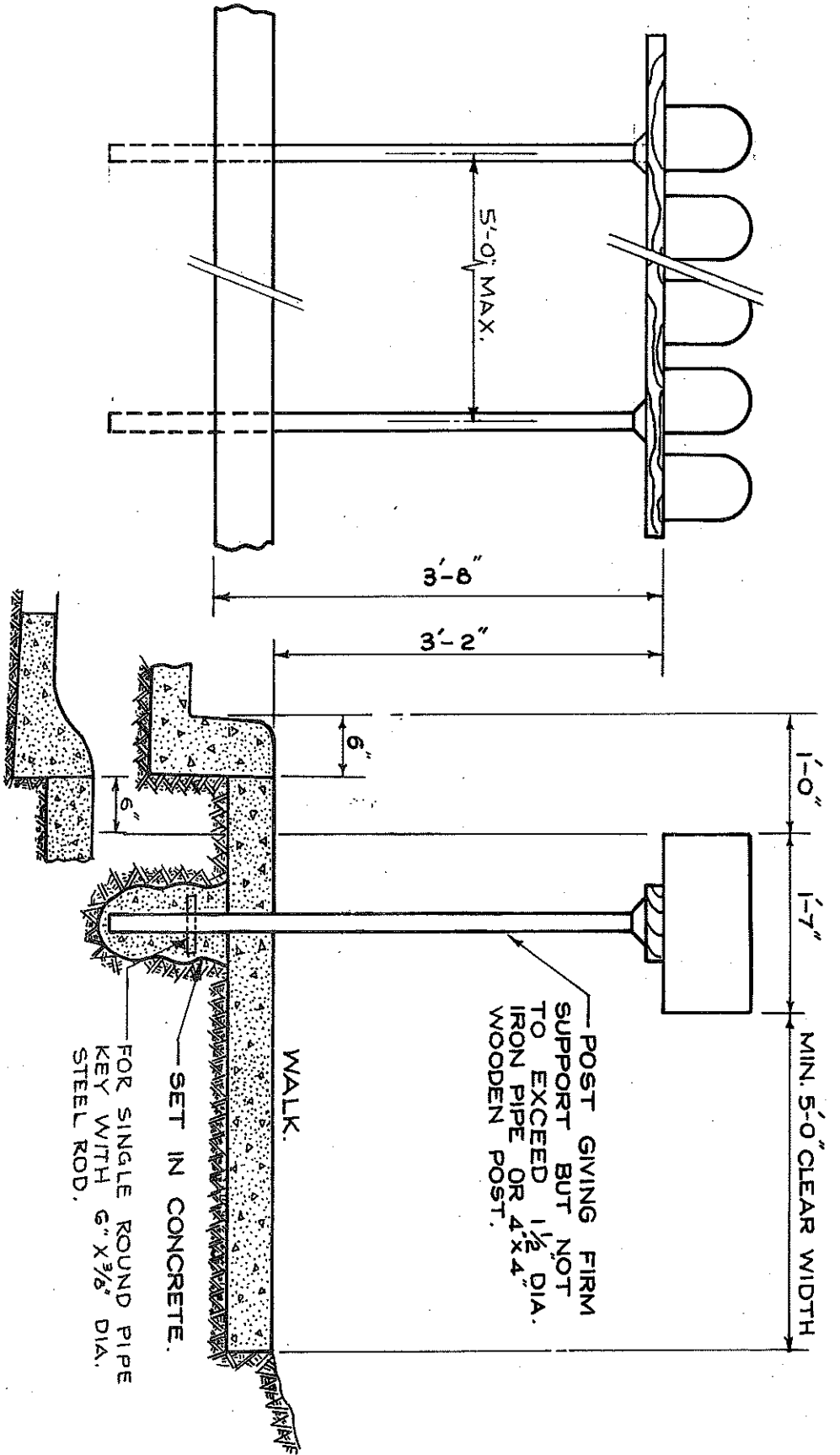

POST GIVING FIRM SUPPORT BUT NOT TO EXCEED 1 1/2" DIA. IRON PIPE OR 4" X 4" WOODEN POST.

WALK.

SET IN CONCRETE.

FOR SINGLE ROUND PIPE KEY WITH 6" X 3/8" DIA. STEEL ROD.

NOTE:

SEE SECTION 5.04 KCRS.

**MAILBOX MOUNTING  
CURB TYPE LOCATION**

KING COUNTY,  
WASHINGTON

DWG. NO. 24

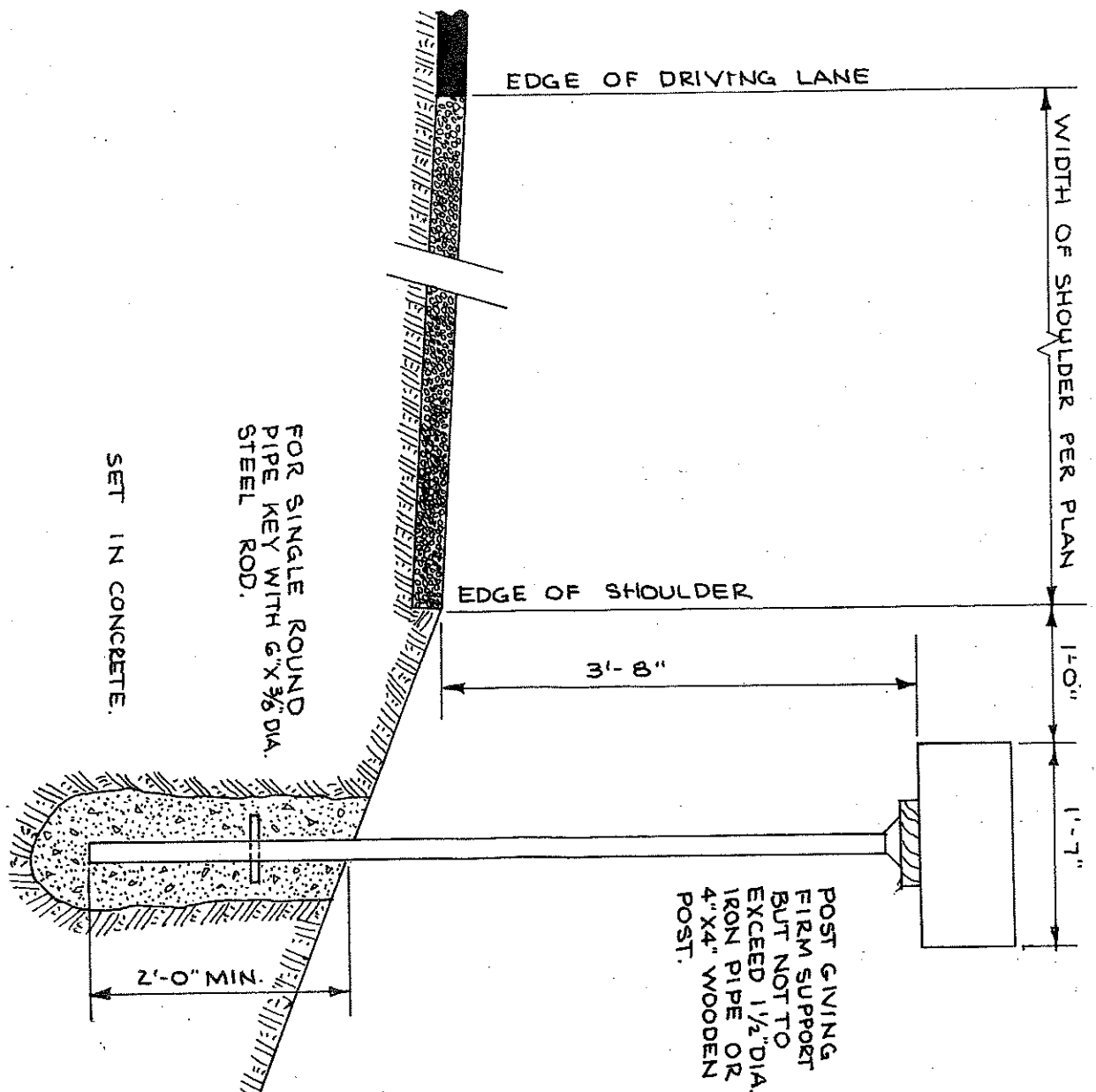
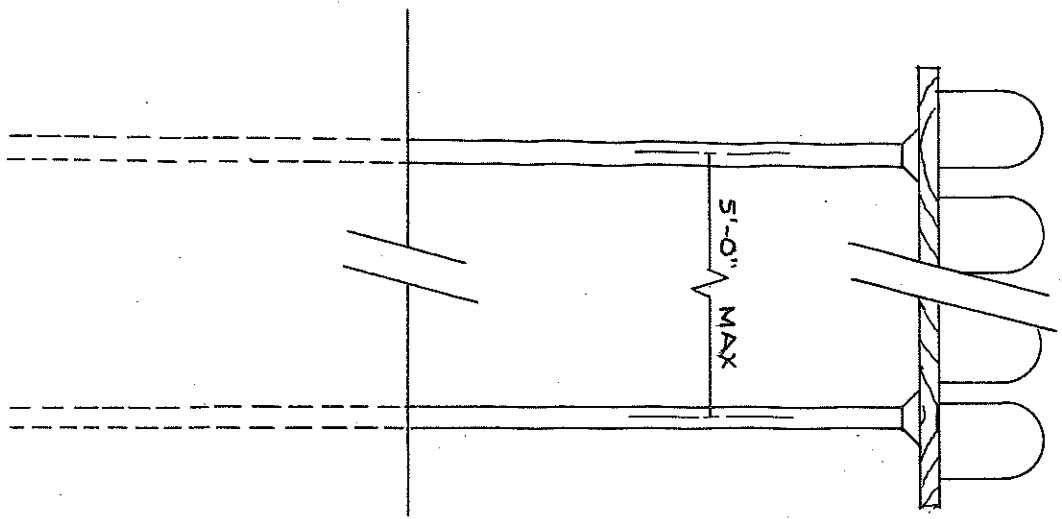

NOTE:  
SEE SEC. 5.04 KCRS.

MAILBOX MOUNTING  
SHOULDER TYPE LOCATION

KING COUNTY,  
WASHINGTON

DWG. NO. 25

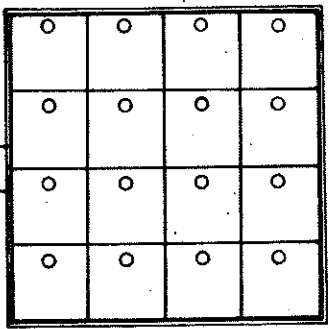

ANCHOR BOLT PATTERN  
PER N.D.C.B.U. PEDESTAL  
TEMPLATE

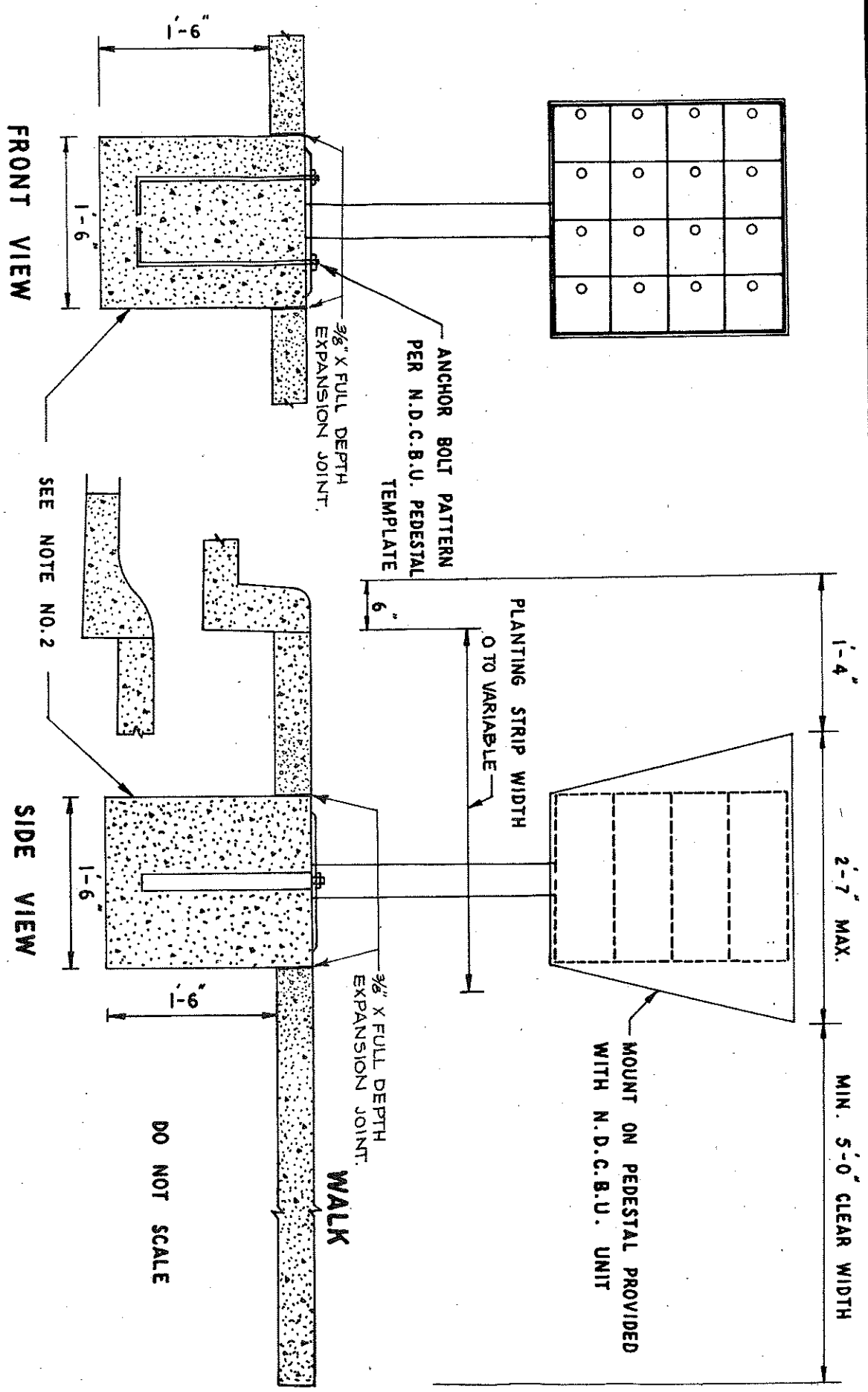

FRONT VIEW

SIDE VIEW

SEE NOTE NO. 2

DO NOT SCALE

WALK

MOUNT ON PEDESTAL PROVIDED  
WITH N.D.C.B.U. UNIT

**NOTES:**

1. SEE SEC. 5.04. KCRS.
2. INSTALLATION OF N.D.C.B.U. INCLUDING CONSTRUCTION OF BASE WILL BE DONE BY U.S. POSTAL SERVICE

NEIGHBORHOOD DELIVERY 8.  
COLLECTION BOX UNIT (N.D.C.B.U.)  
MAILBOX INSTALLATION

KING COUNTY,  
WASHINGTON

DWG. NO. 26

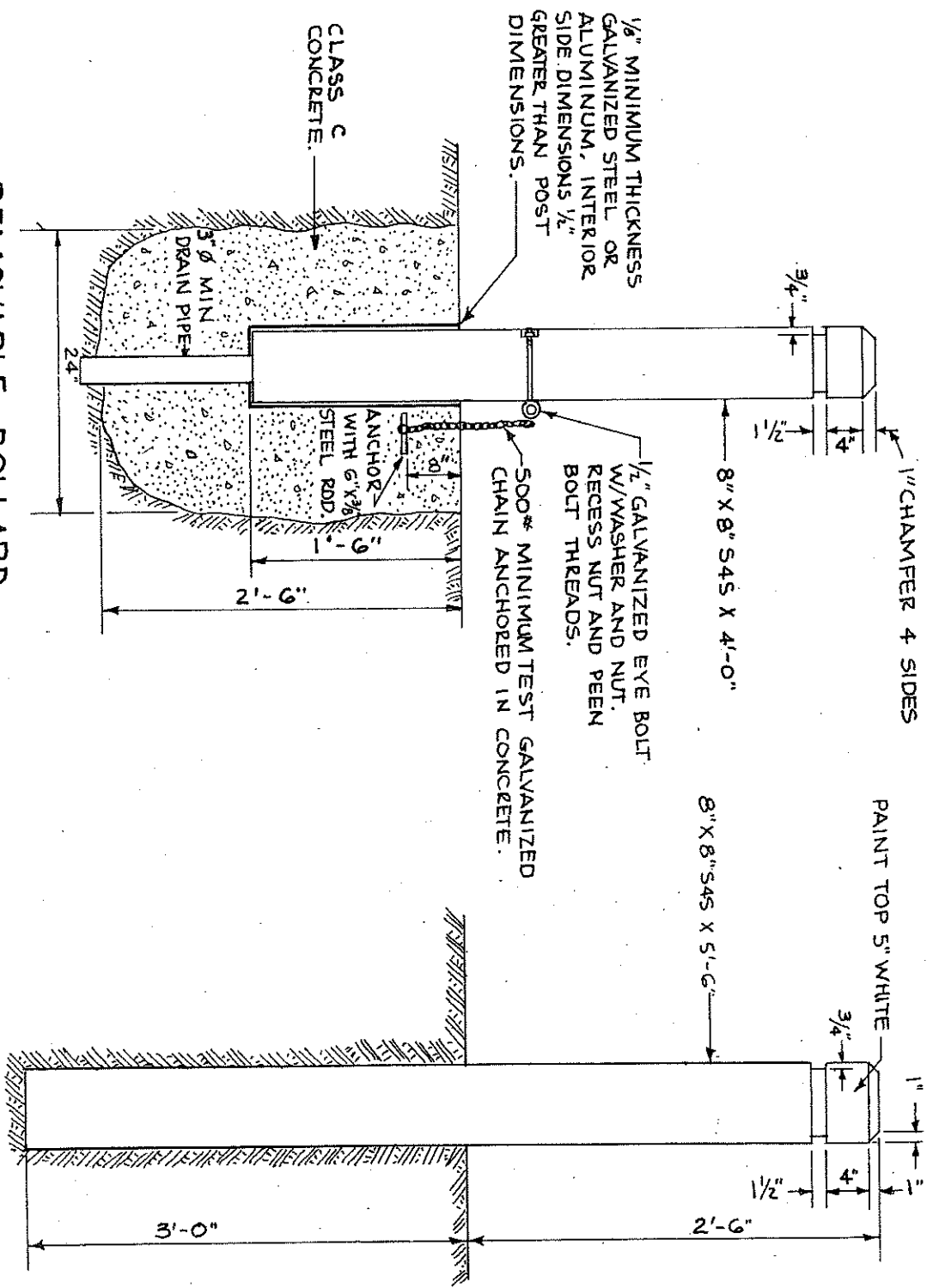

**REMOVABLE BOLLARD**

**FIXED BOLLARD**

**NOTES:**

1. TIMBER SHALL BE DOUGLAS FIR, DENSE CONSTRUCTION GRADE, AND SHALL BE PENTACHLOROPHENOL PRESSURE TREATED BY EMPTY CELL PROCESS WITH MINIMUM NET RETENTION OF 0.05 LBS./CU. FOOT OF THE DRY SALT. (USE LIGHT PETROLEUM SOLVENT.)
2. STEEL TUBE SHALL CONFORM TO ASTM A53 OR ASTM A53 GRADE A.
3. NUTS, BOLTS, & WASHERS SHALL CONFORM TO ASTM A307.
4. ALL STEEL PARTS SHALL BE GALVANIZED.
5. CONCRETE SHALL BE CLASS C.
6. SEE SECTION 5.08 KCRS.

<b>BOLLARDS</b>	
KING COUNTY, WASHINGTON	DWG. NO. <b>27</b>

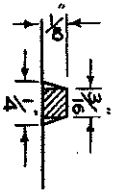

SECTION OF LETTER

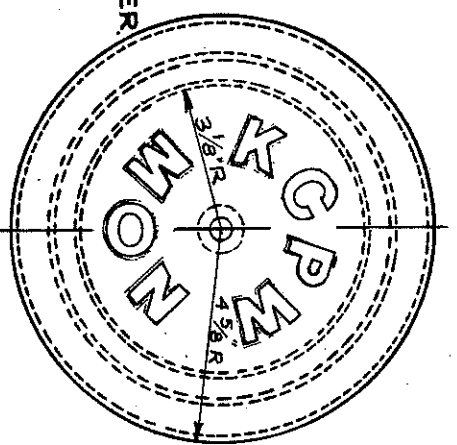

PLAN OF COVER.

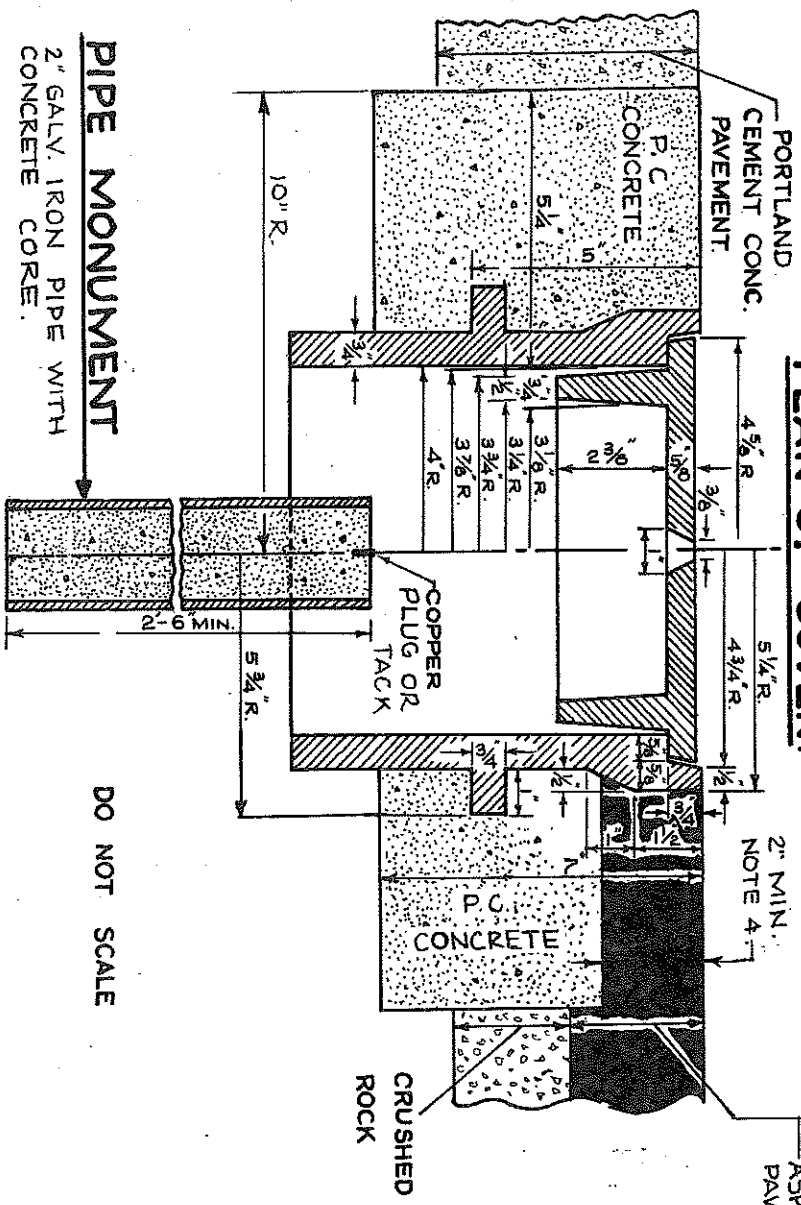

PIPE MONUMENT  
2" GALV. IRON PIPE WITH  
CONCRETE CORE.

SECTION.

DO NOT SCALE

NOTES:

1. CASTINGS SHALL BE GRAY IRON  
ASTM. A-48, CLASS 40.
2. COVER AND SEAT SHALL BE  
MACHINED FOR PERFECT CONTACT  
AROUND CIRCUMFERENCE AND FULL  
WIDTH OF BEARING SURFACE.
3. APPROXIMATE WEIGHTS, STANDARD.  
CASE 60 LBS  
COVER 19 LBS  
TOTAL 79 LBS
4. ASPHALT CONCRETE OR APPROVED  
SUBSTITUTE.
5. CONCRETE SHALL BE CLASS A.

(ALTERNATE)  
CONCRETE  
MONUMENT

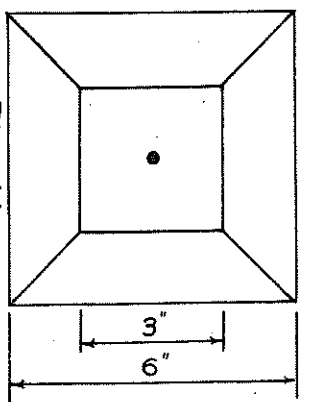

PLAN

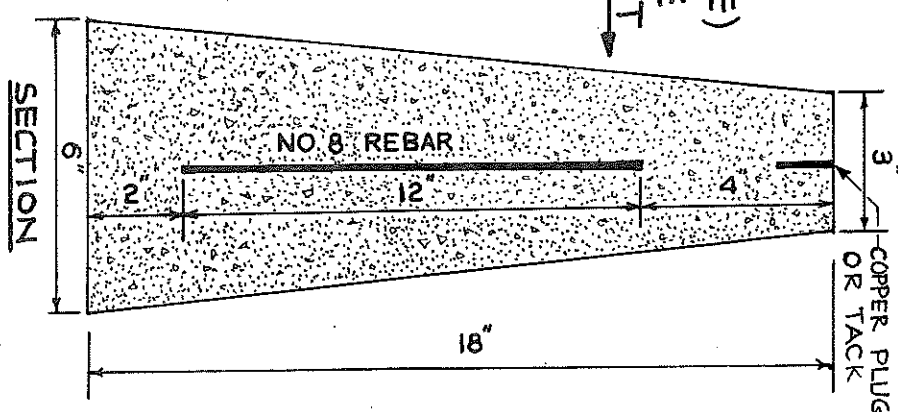

SECTION

ROADWAY SURVEY MONUMENT  
WITH CASE & COVER

KING COUNTY,  
WASHINGTON

DWG. NO. 28

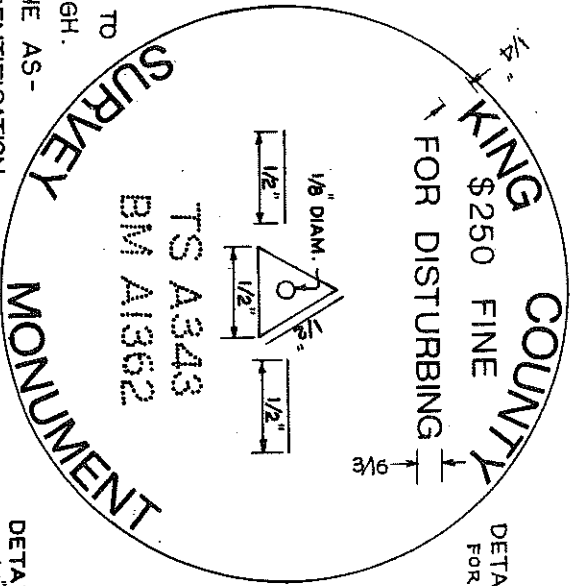

NOTE:  
 DOTTED  
 LETTERS TO  
 BE 3/16 HIGH.  
 ONLY THE AS-  
 SIGNED IDENTIFICATION  
 NUMBERS ARE TO  
 APPEAR ON THE BRASS DISC.

**PLAN.**

DETAIL OF GROOVE  
 FOR 1/4" LETTERS AND LINES.

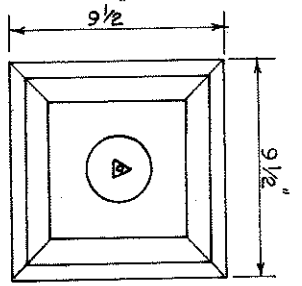

**PLAN**

**LEDGE ROCK OR  
 CONCRETE INSTALLATION.**

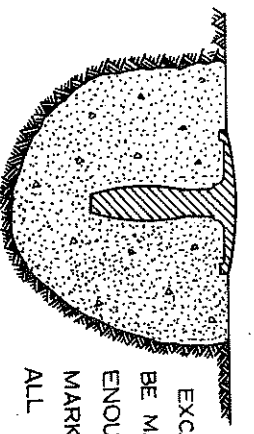

EXCAVATION TO  
 BE MADE LARGE  
 ENOUGH TO CLEAR  
 MARKER 1 1/2" AT  
 ALL POINTS.

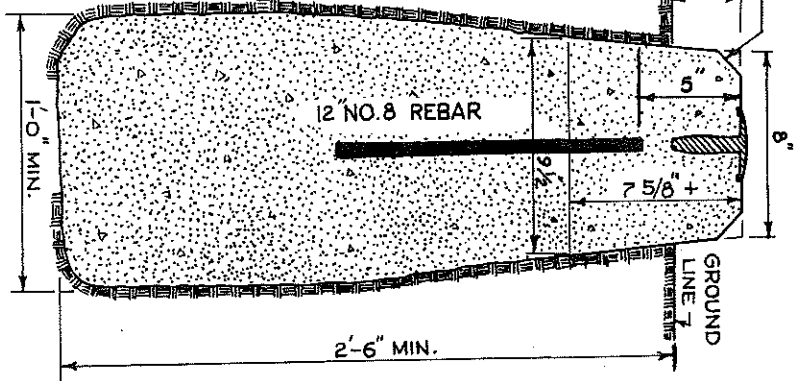

**SECTION.**

**GENERAL INSTALLATION.**

THE BRASS DISC SHALL BE CAST OF  
 YELLOW BRASS SAE 41.  
 CONCRETE SHALL BE CLASS A. MIX.  
 THE HOLE SHALL BE 2.5' MIN. IN  
 DEPTH OR 0.5' BELOW THE DEEPEST  
 RECORDED FROST LINE. ALL LOOSE  
 MATERIAL SHALL BE REMOVED FROM  
 THE BOTTOM OF THE HOLE SO THAT  
 THE CONCRETE IS PLACED ON  
 FIRM, UNDISTURBED EARTH.  
 THE TOP OF THE CONCRETE  
 SHALL BE TROWELED SMOOTH AND  
 THE BRASS DISC SET IN THE  
 CENTER WITH ITS TOP EDGE FLUSH  
 AND LEVEL.  
 COORDINATES OR ELEVATIONS  
 SHALL NOT BE PLACED ON THE  
 BRASS DISCS.

DO NOT SCALE

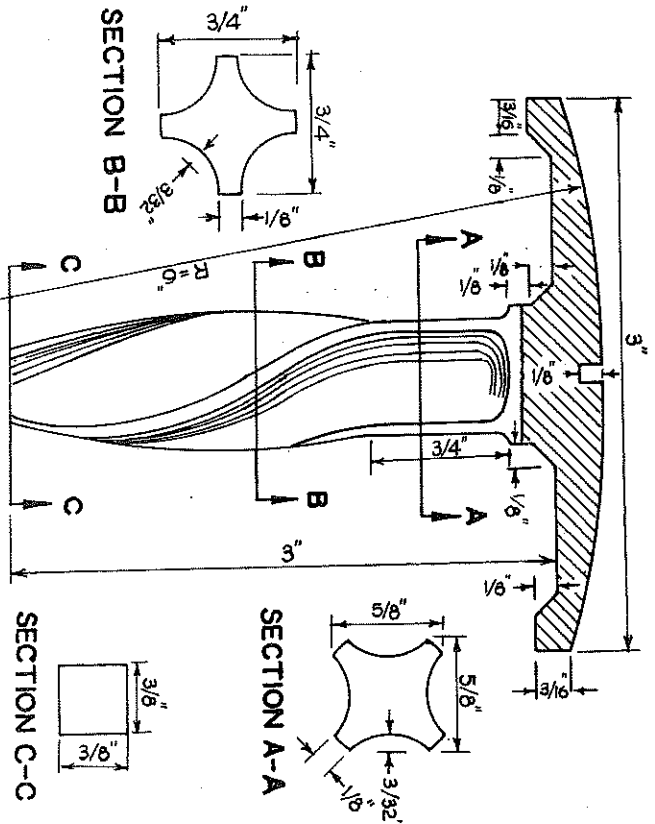

**ELEVATION.**

**BRASS DISC.**

**OFF-ROAD SURVEY MONUMENT**

KING COUNTY,  
 WASHINGTON

DWG. NO. 29

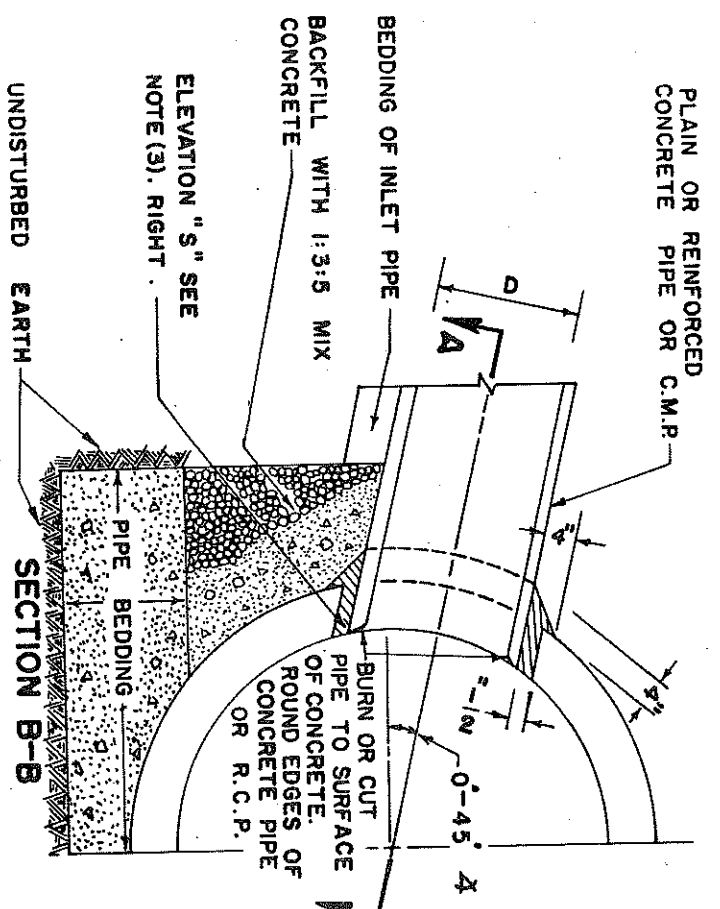

CASE-1

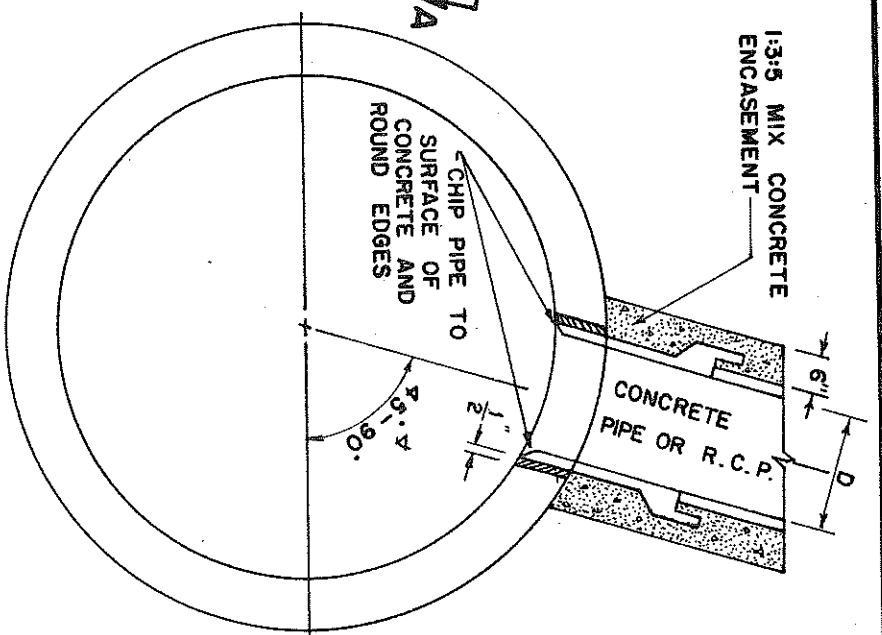

CASE-2

CATCH BASIN ABOVE STORM SEWER

**NOTE:** ALL CONNECTOR PIPES (WITHIN THE ANGLES SPECIFIED FOR CASE 2) SHALL BE ENCASED WHEN LAID WITHIN THE MAIN LINE EXCAVATED TRENCH, OR WHEN LAID ON FILL WHICH HAS NOT BEEN DENSIFIED.

DO NOT SCALE

- NOTES: CASE 1 & 2.
1. "D" SHALL BE 24" OR LESS, FOR LARGER VALUES OF "D" USE AN APPROVED STRUCTURE
  2. STUB SHALL PROJECT 1.5 D FROM MAIN STORM SEWER
  3. IN NO CASE SHALL THE OUTSIDE DIA. OF THE INLET PIPE EXCEED ONE-HALF THE INSIDE DIA. OF THE MAIN STORM SEWER.
  4. Ø OF INLET SHALL BE ON RADIUS OF MAIN STORM DRAIN EXCEPT WHERE ELEVATIONS IS OTHERWISE SPECIFIED.
  5. THE MIN. OPENING INTO THE EXISTING STORM DRAIN SHALL BE THE OUTSIDE DIA. OF THE CONNECTING PIPE PLUS 1/16".
  6. IF Ø IS 45° OR LESS, USE CASE-1; IF Ø IS GREATER THAN 45°, USE CASE-2.

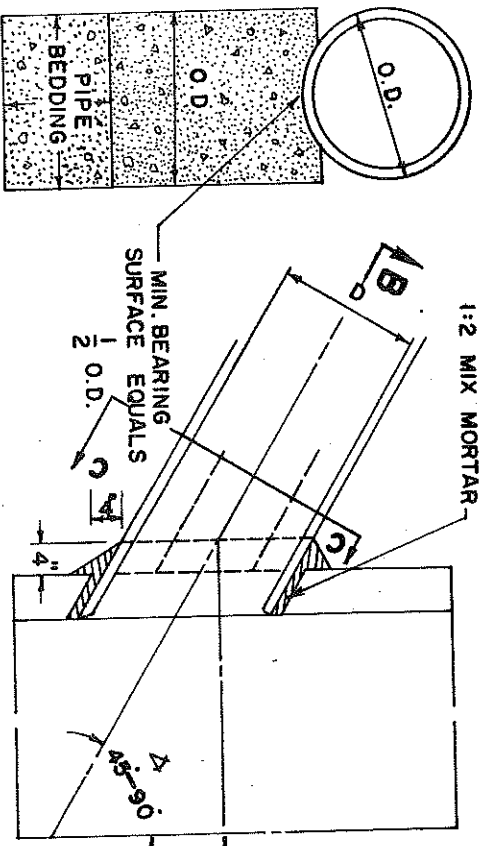

CASE-1 SIDE INLET

FIELD-TAPPING OF CONCRETE PIPE

KING COUNTY, WASHINGTON DWG. NO. 30

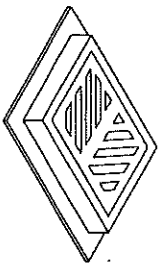

Frame and grate  
SEE SEC. 7.07 KCRS AND  
APPLICABLE DRAWINGS KCRS.

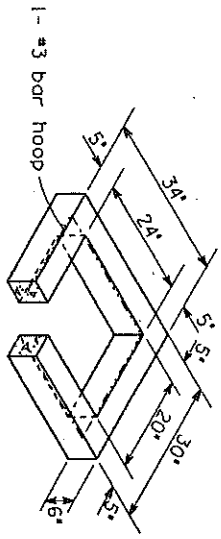

6' Riser Section

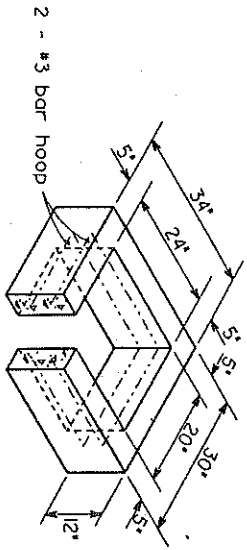

12' Riser Section

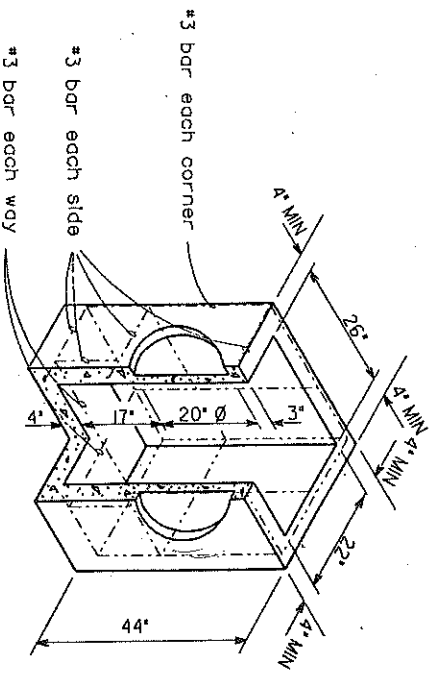

Precast Base Section  
(Measurement of the top  
of the base)

NOTES:

1. CATCH BASINS TO BE CONSTRUCTED IN ACCORDANCE WITH ASTM C478 & ASTM C890 UNLESS OTHERWISE SHOWN ON PLANS OR NOTED IN THE STANDARD SPECIFICATIONS.
2. AS AN ACCEPTABLE ALTERNATE TO REBAR, WELDED WIRE FABRIC HAVING A MINIMUM AREA OF 0.12 SQUARE INCHES PER FOOT MAY BE USED. WELDED WIRE FABRIC SHALL COMPLY TO ASTM A497.
3. ALL REINFORCED CAST IN PLACE CONCRETE SHALL BE CLASS A.
4. PRECAST BASES SHALL BE FURNISHED WITH CUTOUTS OR KNOCKOUTS. KNOCKOUTS SHALL HAVE A WALL THICKNESS OF 2" MINIMUM. ALL PIPE SHALL BE INSTALLED IN FACTORY PROVIDED KNOCKOUTS. UNUSED KNOCKOUTS NEED NOT BE GROUDED IF WALL IS LEFT INTACT.
5. KNOCKOUT OR CUTOUT HOLE SIZE IS EQUAL TO PIPE OUTER DIAMETER PLUS CATCH BASIN WALL THICKNESS.
6. ROUND KNOCKOUTS MAY BE ON ALL 4 SIDES.
7. THE MAXIMUM DEPTH FROM THE FINISHED GRADE TO THE PIPE INVERT IS 5'-0".
8. THE TAPER ON THE SIDES OF THE PRECAST BASE SECTION AND RISER SECTION SHALL NOT EXCEED 1/4"/FT.
9. CATCH BASIN FRAME AND GRATE SHALL BE IN ACCORDANCE WITH STANDARD SPECIFICATIONS AND MEET THE STRENGTH REQUIREMENTS OF FEDERAL SPECIFICATION RR-F-621D. MATING SURFACES SHALL BE FINISHED TO ASSURE NON-ROCKING FIT WITH ANY COVER POSITION.
10. FRAME AND GRATE MAY BE INSTALLED WITH FLANGE DOWN OR CAST INTO RISER.

(SEE WSDOT/APWA  
STANDARD PLAN B-1)

CATCH BASIN TYPE 1

KING COUNTY,  
WASHINGTON

DWG. NO. 31

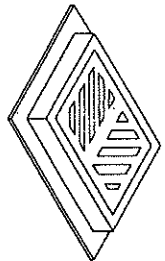

Frame and grate  
SEE SEC. 7.07 KCERS AND  
APPLICABLE DRAWINGS KCERS.

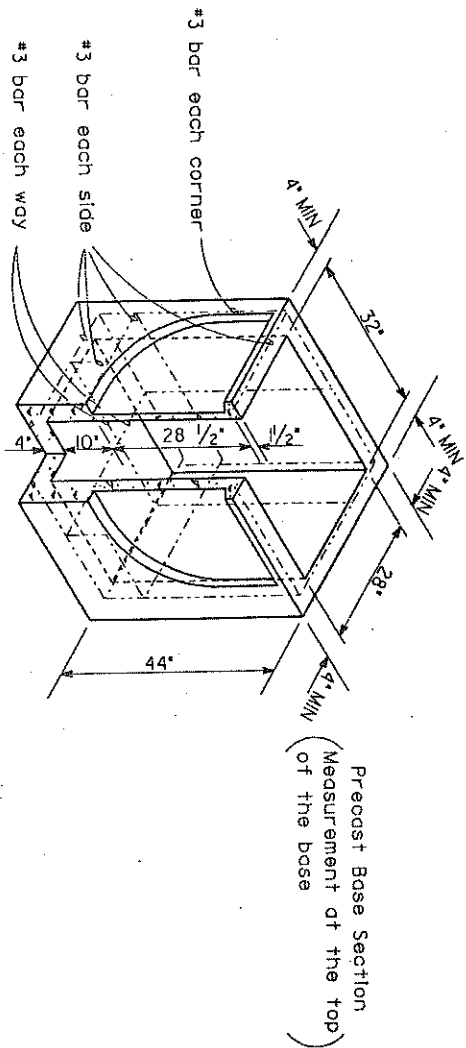
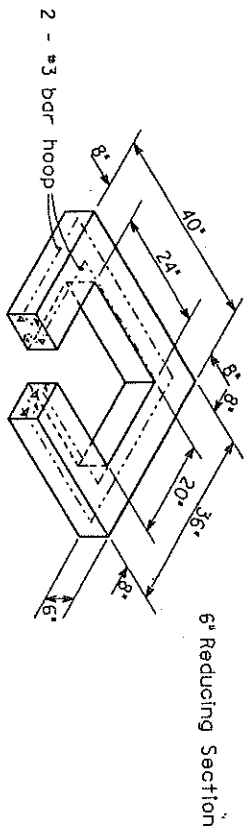
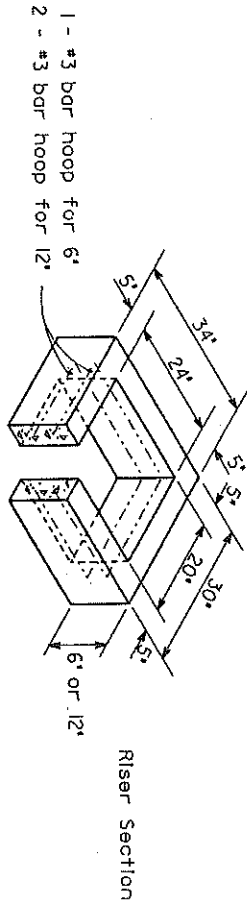

- NOTES:
1. CATCH BASINS TO BE CONSTRUCTED IN ACCORDANCE WITH ASTM C478 & ASTM C890 UNLESS OTHERWISE SHOWN ON PLANS OR NOTED IN THE STANDARD SPECIFICATIONS.
  2. AS AN ACCEPTABLE ALTERNATE TO REBAR, WELDED WIRE FABRIC HAVING A MINIMUM AREA OF 0.12 SQUARE INCHES PER FOOT MAY BE USED. WELDED WIRE FABRIC SHALL COMPLY TO ASTM A497.
  3. ALL REINFORCED CAST IN PLACE CONCRETE SHALL BE CLASS A.
  4. PRECAST BASES SHALL BE FURNISHED WITH CUTOUTS OR KNOCKOUTS. KNOCKOUTS SHALL HAVE A WALL THICKNESS OF 2" MINIMUM. ALL PIPE SHALL BE INSTALLED IN FACTORY PROVIDED KNOCKOUTS. UNUSED KNOCKOUTS NEED NOT BE GROUTED IF WALL IS LEFT INTACT.
  5. KNOCKOUT OR CUTOUT HOLE SIZE IS EQUAL TO PIPE OUTER DIAMETER PLUS CATCH BASIN WALL THICKNESS.
  6. KNOCKOUTS MAY BE ON ALL 4 SIDES. KNOCKOUTS MAY BE EITHER 28 INCH DIAMETER ROUND OR "D" SHAPE.
  7. CATCH BASIN FRAME AND GRATE SHALL BE IN ACCORDANCE WITH STANDARD SPECIFICATIONS AND MEET THE STRENGTH REQUIREMENTS OF FEDERAL SPECIFICATION RR-F-621D. MATING SURFACES SHALL BE FINISHED TO ASSURE NON-ROCKING FIT WITH ANY COVER POSITION.
  9. THE TAPER ON THE SIDES OF THE PRECAST BASE SECTION AND RISER SECTION SHALL NOT EXCEED 1/4"/FT.
  10. FRAME AND GRATE MAY BE INSTALLED WITH FLANGE DOWN OR CAST INTO RISER.

(SEE WSDOT/APWA STANDARD PLAN B1a)	
<b>CATCH BASIN TYPE 1-L</b>	DWG. NO. <b>32</b>
KING COUNTY, WASHINGTON	

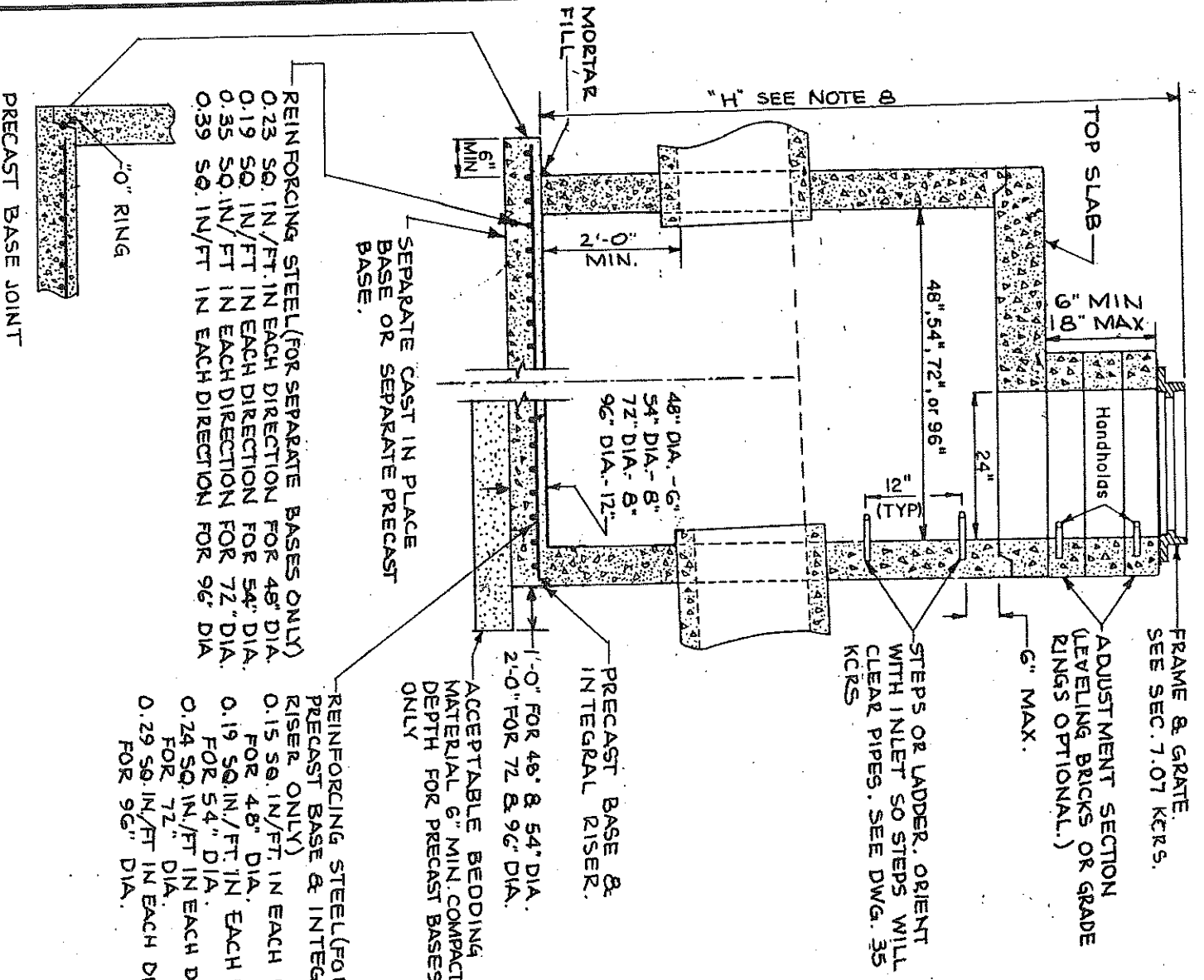

REINFORCING STEEL (FOR SEPARATE BASES ONLY)  
 0.23 SQ. IN./FT. IN EACH DIRECTION FOR 48" DIA.  
 0.19 SQ. IN./FT. IN EACH DIRECTION FOR 54" DIA.  
 0.35 SQ. IN./FT. IN EACH DIRECTION FOR 72" DIA.  
 0.39 SQ. IN./FT. IN EACH DIRECTION FOR 96" DIA.

REINFORCING STEEL (FOR PRECAST BASE & INTEGRAL RISER ONLY)  
 0.15 SQ. IN./FT. IN EACH DIRECTION FOR 48" DIA.  
 0.19 SQ. IN./FT. IN EACH DIRECTION FOR 54" DIA.  
 0.24 SQ. IN./FT. IN EACH DIRECTION FOR 72" DIA.  
 0.29 SQ. IN./FT. IN EACH DIRECTION FOR 96" DIA.

ACCEPTABLE BEDDING MATERIAL 6" MIN. COMPACTED DEPTH FOR PRECAST BASES ONLY

PRECAST BASE & INTEGRAL RISER.

PRECAST BASE JOINT

0" RING

FRAME & GRATE. SEE SEC. 7.07 KCRS.

ADJUSTMENT SECTION (LEVELING BRICKS OR GRADE RINGS OPTIONAL)

STEPS OR LADDER, ORIENT WITH INLET SO STEPS WILL CLEAR PIPES. SEE DWG. 35 KCRS

NOTES:

- CATCH BASINS SHALL BE CONSTRUCTED IN ACCORDANCE WITH AASHTO M-199 UNLESS OTHERWISE SHOWN ON PLANS OR NOTED IN THE WSDOT/APWA STANDARD SPECIFICATIONS.
- HANDHOLDS IN ADJUSTMENT SECTION SHALL HAVE 3" MINIMUM CLEARANCE. STEPS IN CATCH BASIN SHALL HAVE 6" MINIMUM CLEARANCE. SEE DWG. NO. 39 KCRS, "MANHOLE DETAILS."
- ALL REINFORCED CAST-IN-PLACE CONCRETE SHALL BE CLASS A. ALL PRECAST CONCRETE SHALL BE CLASS AX.
- PRECAST BASES SHALL BE FURNISHED WITH CUTOUTS OR KNOCKOUTS. KNOCKOUTS SHALL HAVE A WALL THICKNESS OF 2" MINIMUM. UNUSED KNOCKOUTS NEED NOT BE GROTTED IF WALL IS LEFT INTACT. PIPES SHALL BE INSTALLED ONLY IN FACTORY KNOCKOUTS UNLESS OTHERWISE APPROVED BY THE ENGINEER.
- KNOCKOUT OR CUTOOUT HOLE SIZE SHALL EQUAL PIPE OUTER DIAMETER PLUS CATCH BASIN WALL THICKNESS. MAXIMUM HOLE SIZE SHALL BE 36" FOR 48" C.B., 42" FOR 54" C.B., 60" FOR 72" C.B., 84" FOR 96" C.B. MINIMUM DISTANCE BETWEEN HOLES SHALL BE 8" FOR 48" AND 54" C.B.; 12" FOR 72" AND 96" C.B.
- CATCH BASIN FRAMES AND GRATERS OR COVERS SHALL BE IN ACCORDANCE WITH SEC. 7.07 KCRS AND MEET THE STRENGTH REQUIREMENTS OF FEDERAL SPECIFICATION RR-F-621D. MATING SURFACES SHALL BE FINISHED TO ASSURE NON-ROCKING FIT WITH ANY COVER POSITION.
- ALL BASE REINFORCING STEEL SHALL HAVE A MINIMUM YIELD STRENGTH OF 60,000 PSI AND BE PLACED IN THE UPPER HALF OF THE BASE WITH 1" MINIMUM CLEARANCE.
- FOR HEIGHTS "H" OF 12' OR LESS, MINIMUM SOIL BEARING VALUE SHALL EQUAL 3,300 POUNDS PER SQUARE FOOT. FOR HEIGHTS OVER 12', MINIMUM SOIL BEARING VALUE SHALL EQUAL 3,800 POUNDS PER SQUARE FOOT.
- FOR DETAILS SHOWING LADDER, STEPS, & HANDHOLDS SEE DWG. NO. 39 KCRS. FOR TOP SLABS, SEE DWG. NO. 34 KCRS.
- SEE THE WSDOT/APWA STANDARD SPECIFICATIONS SECTION 7-05.3 FOR JOINT REQUIREMENTS.

(SEE WSDOT/APWA STANDARD PLANS B-1e & B-1f.)  
**CATCH BASIN TYPE 2**  
 48", 54", 72", & 96"

KING COUNTY,  
 WASHINGTON

DWG. NO. 333

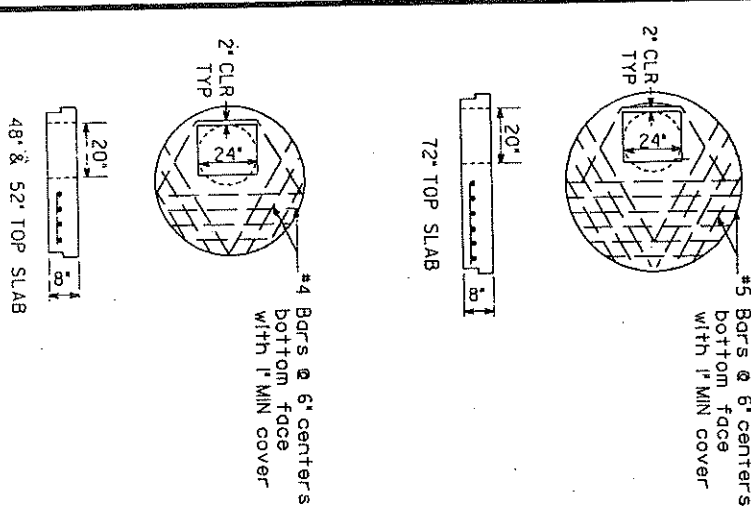
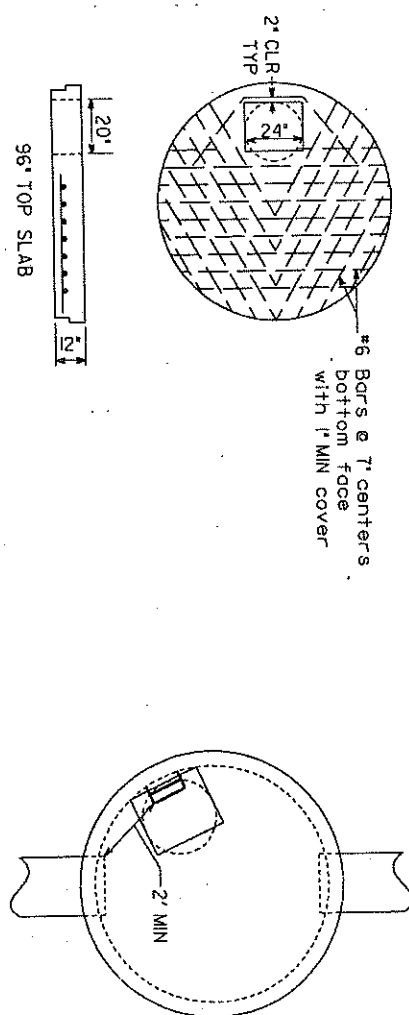

TYPICAL ORIENTATION FOR ACCESS AND STEPS

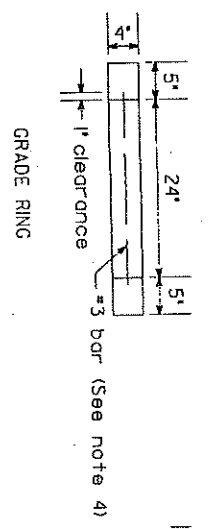
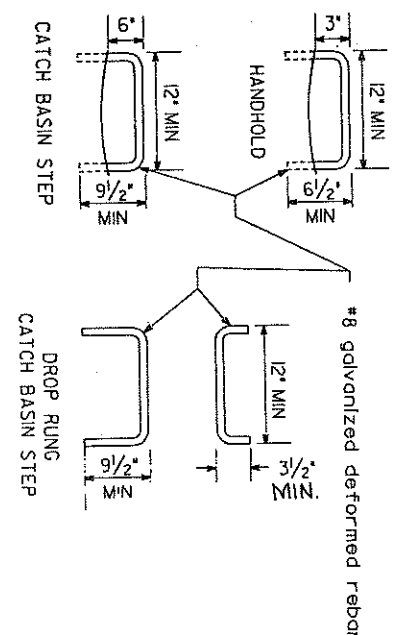

NOTES:

1. PROPRIETARY CATCH BASIN HAND HOLDS AND STEPS ARE ACCEPTABLE, PROVIDED THAT THEY CONFORM TO SECTION R. AASHTO M-199 AND MEET ALL WISHA REQUIREMENTS.
2. CATCH BASIN STEP/HAND HOLD LEGS SHALL BE PARALLEL OR APPROXIMATELY RADIAL AT THE OPTION OF THE MANUFACTURER, EXCEPT THAT ALL STEPS IN ANY CATCH BASIN SHALL BE SIMILAR. PENETRATION OF OUTER WALL BY A LEG IS PROHIBITED.
3. HAND HOLDS AND STEPS SHALL HAVE "DROP" RUNGS AS SHOWN ON DETAIL OR PROTRUDANCES TO PREVENT SIDEWAYS SLIP.
4. SLAB OPENING MAY BE 24" X 20" OR 24" DIAMETER.
5. AS AN ACCEPTABLE ALTERNATE TO REBAR, WELDED WIRE FABRIC HAVING A MINIMUM AREA OF 0.12 SQUARE INCHES PER FOOT MAY BE USED. WELDED WIRE FABRIC SHALL COMPLY TO ASTM A 497.
6. LADDERS OR STEPS SHALL EXTEND TO WITHIN 16" OF BOTTOM OF CATCH BASIN.
7. HANGING LADDERS SHALL BE PERMANENTLY FASTENED AT TOP BY HANGING ON STEP OR BY BOLTING OR IMBEDDING IN CONCRETE. EACH SHALL BE IMBEDDED AT BOTTOM IN BASE.
8. ADDITIONAL SAFETY FEATURES MAY BE REQUIRED IN VERY DEEP OR UNUSUAL STRUCTURES.

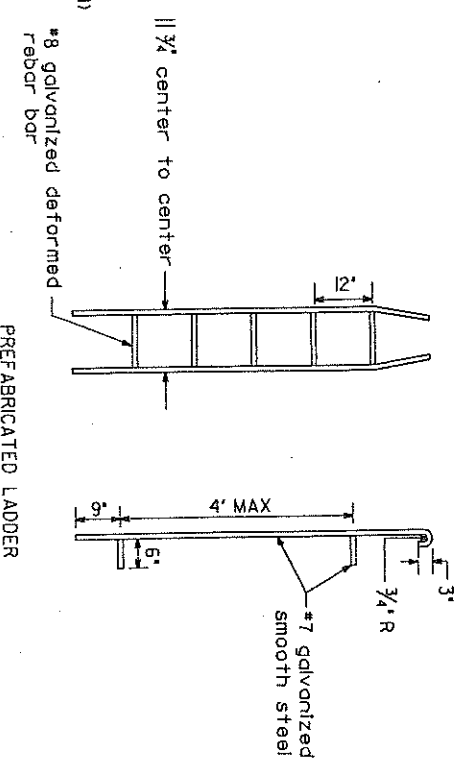

PREFABRICATED LADDER (SEE WSDOT/APWA STANDARD PLAN B-12)

CATCH BASIN DETAILS

KING COUNTY WASHINGTON DWG. NO. 34

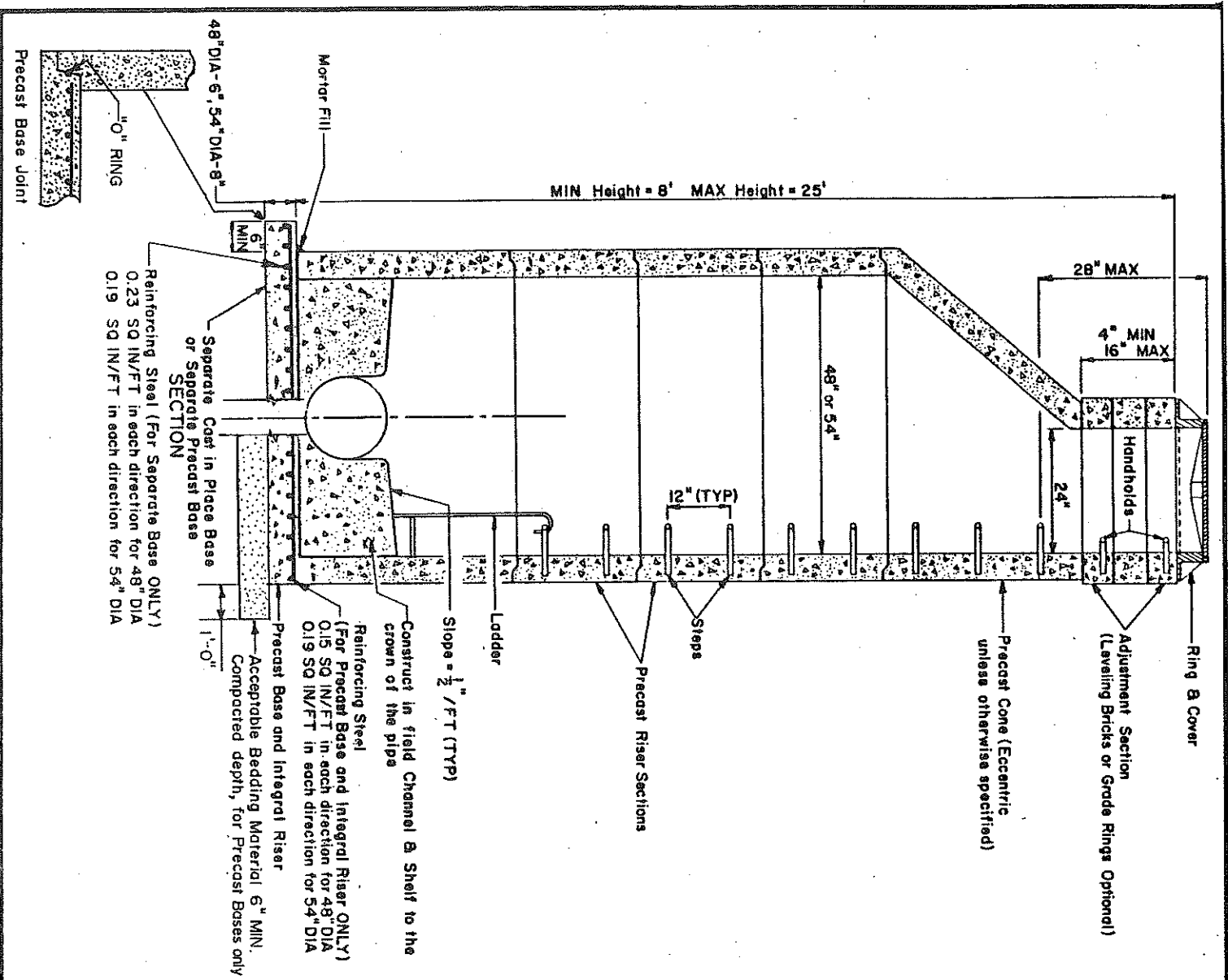

MIN Height = 8' MAX Height = 25'

26" MAX

4" MIN 16" MAX

Handholds

24"

Ring B Cover

Adjustment Section (Leveling Bricks or Grade Rings Optional)

Precast Cone (Eccentric unless otherwise specified)

48" or 54"

12" (TYP)

Steps

Precast Riser Sections

Slope = 1/2" / FT (TYP)

Ladder

Construct in field Channel & Shelf to the crown of the pipe

Reinforcing Steel (For Precast Base and Integral Riser ONLY) 0.15 SQ IN/FT in each direction for 48" DIA 0.19 SQ IN/FT in each direction for 54" DIA

Precast Base and Integral Riser

Acceptable Bedding Material 6" MIN. Compacted depth, for Precast Bases only

1'-0"

Separate Cast in Place Base or Separate Precast Base

Reinforcing Steel (For Separate Base ONLY) 0.23 SQ IN/FT in each direction for 48" DIA 0.19 SQ IN/FT in each direction for 54" DIA

6" MIN

Motor Fill

48" DIA - 6" 54" DIA - 8"

0" RING

Precast Base Joint

NOTES:

1. MANHOLES SHALL BE CONSTRUCTED IN ACCORDANCE WITH AASHTO M-199 UNLESS OTHERWISE SHOWN ON PLANS OR NOTED IN THE WSDOT/APWA STANDARD SPECIFICATIONS.
2. HANDHOLDS IN ADJUSTMENT SECTION SHALL HAVE 3" MINIMUM CLEARANCE. STEPS IN MANHOLE SHALL HAVE 6" MINIMUM CLEARANCE. SEE DWG. NO. 39 KCRS, "MANHOLE DETAILS."
3. ALL REINFORCED CAST-IN-PLACE CONCRETE SHALL BE CLASS A. NON-REINFORCED CONCRETE IN CHANNEL AND SHELF SHALL BE CLASS C. ALL PRECAST CONCRETE SHALL BE CLASS AX.
4. PRECAST BASES SHALL BE FURNISHED WITH CUTOUTS OR KNOCKOUTS. KNOCKOUTS SHALL HAVE A WALL THICKNESS OF 2" MINIMUM. UNUSED KNOCKOUTS NEED NOT BE GROUTED IF WALL IS LEFT INTACT. PIPES SHALL BE INSTALLED ONLY IN FACTORY KNOCKOUTS UNLESS OTHERWISE APPROVED BY THE ENGINEER.
5. KNOCKOUT OR CUTOUT HOLE SIZE SHALL EQUAL PIPE OUTER DIAMETER PLUS MANHOLE WALL THICKNESS. MAXIMUM HOLE SIZE SHALL BE 36" FOR 48" MANHOLE, 42" FOR 54" MANHOLE. MINIMUM DISTANCE BETWEEN HOLES SHALL BE 8".
6. MANHOLE RINGS AND COVERS SHALL BE IN ACCORDANCE WITH SEC. 7.07 KCRS AND MEET THE STRENGTH REQUIREMENTS OF FEDERAL SPECIFICATION RR-F-621D. MATING SURFACES SHALL BE FINISHED TO ASSURE NON-ROCKING FIT WITH ANY COVER POSITION.
7. ALL BASE REINFORCING STEEL SHALL HAVE A MINIMUM YIELD STRENGTH OF 60,000 PSI AND BE PLACED IN THE UPPER HALF OF THE BASE WITH 1" MINIMUM CLEARANCE.
8. FOR HEIGHTS OF 12' OR LESS, MINIMUM SOIL BEARING VALUE SHALL EQUAL 3,300 POUNDS PER SQUARE FOOT. FOR HEIGHTS OVER 12', MINIMUM SOIL BEARING VALUE SHALL EQUAL 3,800 POUNDS PER SQUARE FOOT.
9. FOR DETAILS SHOWING GRADE RING, LADDER, STEPS, HANDHOLDS AND TOP SLABS, SEE DWG. NO. 39 KCRS, "MANHOLE DETAILS."
10. SEE SEC. 7-05.3, WSDOT/APWA STANDARD SPECIFICATIONS FOR JOINT REQUIREMENTS.

(SEE WSDOT/APWA STANDARD PLAT B-23a

MANHOLE TYPE 1

48" & 54"

KING COUNTY, WASHINGTON DWG. NO. 35

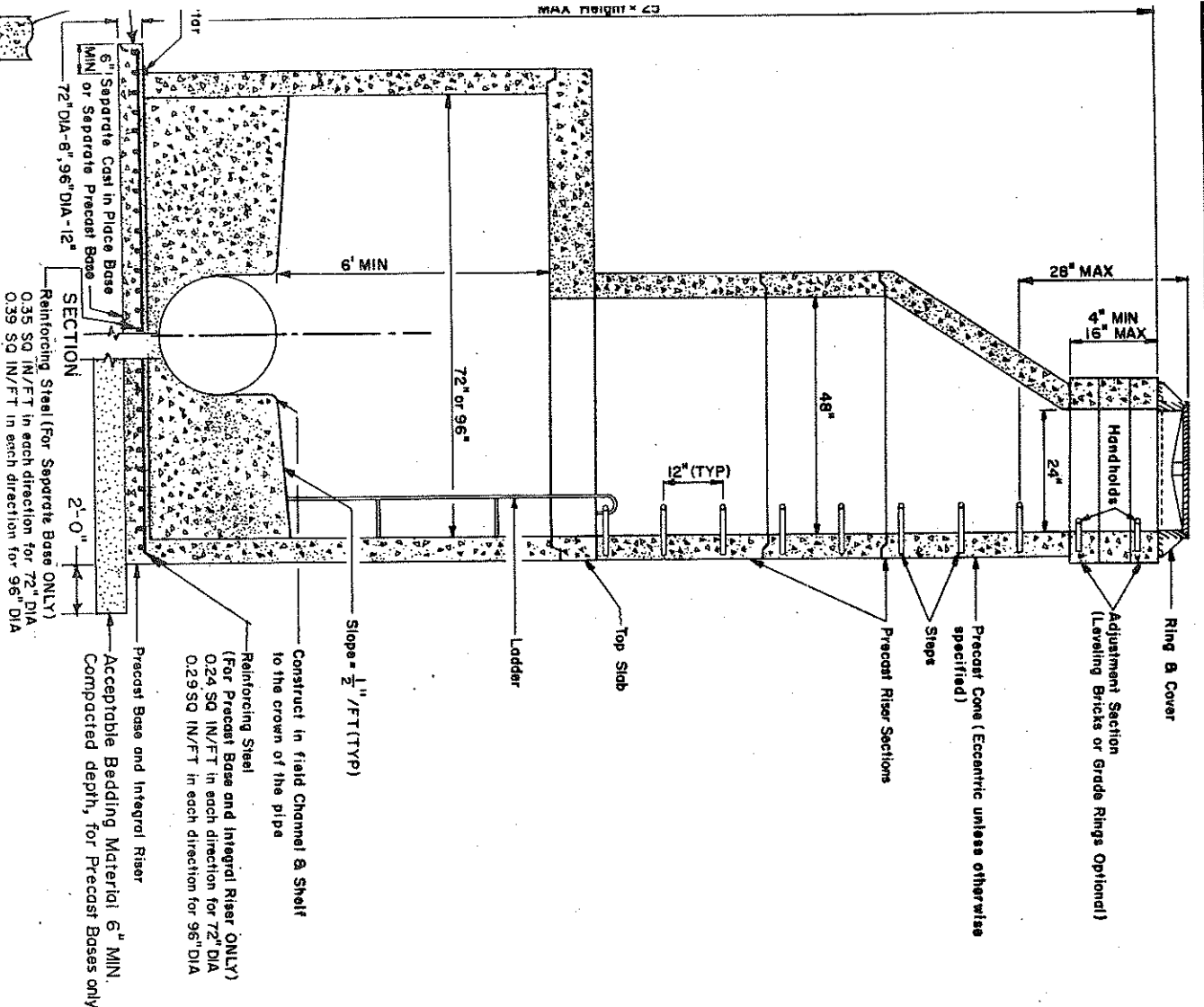

NOTES:

1. MANHOLES SHALL BE CONSTRUCTED IN ACCORDANCE WITH ASHTO M-199 UNLESS OTHERWISE SHOWN ON PLANS OR NOTED IN THE WSDOT/APWA STANDARD SPECIFICATIONS.
2. HANDHOLDS IN ADJUSTMENT SECTION SHALL HAVE 3" MINIMUM CLEARANCE. STEPS IN MANHOLE SHALL HAVE 6" MINIMUM CLEARANCE. SEE DWG. NO. 39 KCRS, "MANHOLE DETAILS."
3. ALL REINFORCED CAST-IN-PLACE CONCRETE SHALL BE CLASS A. NON-REINFORCED CONCRETE IN CHANNEL AND SHELF SHALL BE CLASS C. ALL PRECAST CONCRETE SHALL BE CLASS AX.
4. PRECAST BASES SHALL BE FURNISHED WITH CUTOUTS OR KNOCKOUTS. KNOCKOUTS SHALL HAVE A WALL THICKNESS OF 2" MINIMUM. UNUSED KNOCKOUTS NEED NOT BE GROUTED IF WALL IS LEFT INTACT. PIPES SHALL BE INSTALLED ONLY IN FACTORY KNOCKOUTS UNLESS OTHERWISE APPROVED BY THE ENGINEER.
5. KNOCKOUT OR CUTOUT HOLE SIZE SHALL EQUAL PIPE OUTER DIAMETER PLUS MANHOLE WALL THICKNESS. MAXIMUM HOLE SIZE SHALL BE 60" FOR 72" MANHOLE, 84" FOR 96" MANHOLE. MINIMUM DISTANCE BETWEEN HOLES SHALL BE 12".
6. MANHOLE RINGS AND COVERS SHALL BE IN ACCORDANCE WITH SEC. 7.07 KCRS AND MEET THE STRENGTH REQUIREMENTS OF FEDERAL SPECIFICATION RR-F-621D. MATING SURFACES SHALL BE FINISHED TO ASSURE NON-ROCKING FIT WITH ANY COVER POSITION.
7. ALL BASE REINFORCING STEEL SHALL HAVE A MINIMUM YIELD STRENGTH OF 60,000 PSI AND BE PLACED IN THE UPPER HALF OF THE BASE WITH 1" MINIMUM CLEARANCE.
8. FOR HEIGHTS OF 12' OR LESS, MINIMUM SOIL BEARING VALUE SHALL EQUAL 3,300 POUNDS PER SQUARE FOOT. FOR HEIGHTS OVER 12', MINIMUM SOIL BEARING VALUE SHALL EQUAL 3,800 POUNDS PER SQUARE FOOT.
9. FOR DETAILS SHOWING GRADE RING, LADDER, STEPS, HANDHOLDS AND TOP SLABS, SEE DWG. NO. 39 KCRS, "MANHOLE DETAILS."
10. SEE SEC. 7-05.3, WSDOT/APWA STANDARD SPECIFICATIONS FOR JOINT REQUIREMENTS.

(SEE WSDOT/APWA STANDARD PLAN B 23 b)

MANHOLE TYPE 2

72" & 96"

KING COUNTY WASHINGTON	DWG. NO. 36
---------------------------	-------------

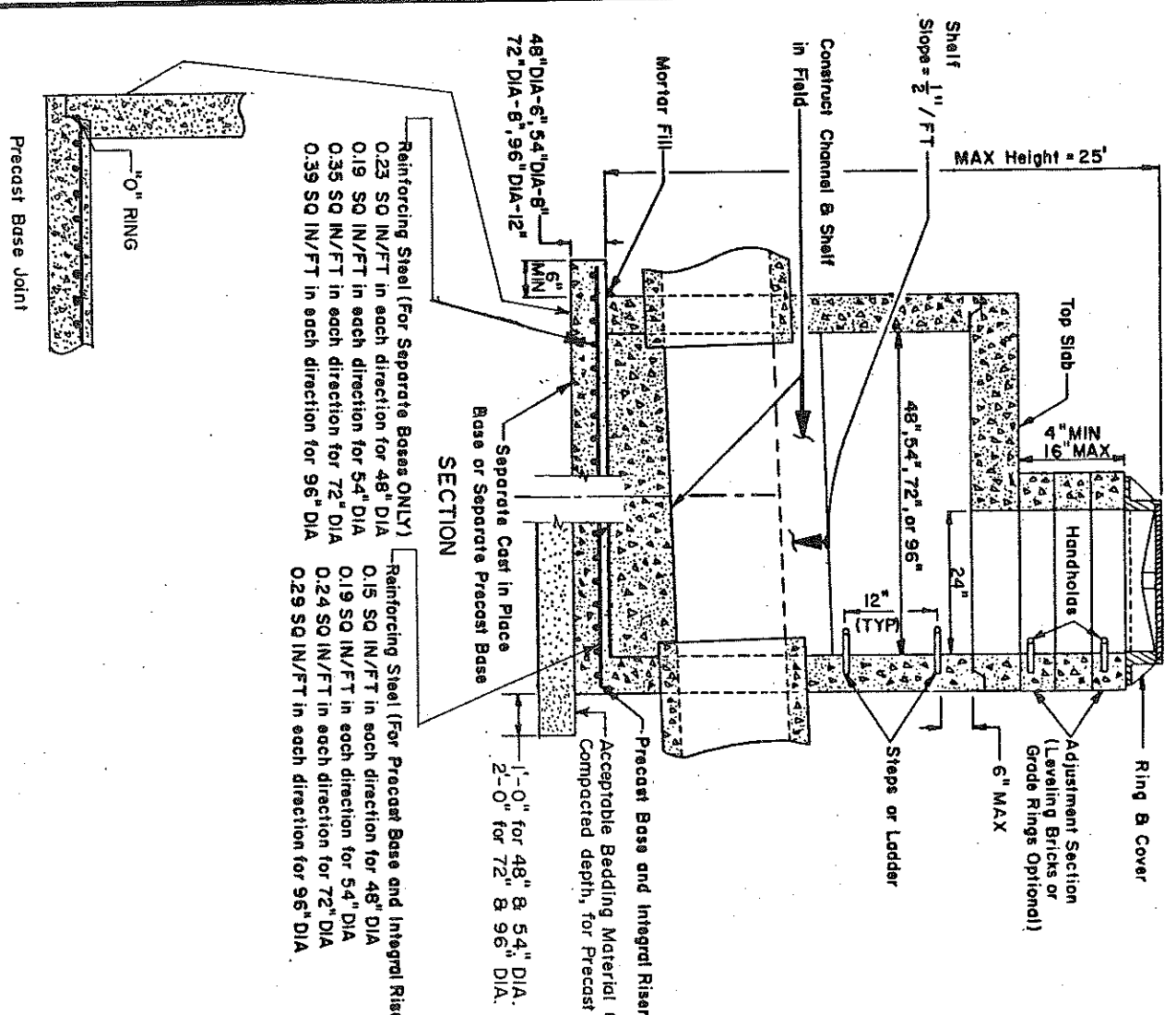

Reinforcing Steel (For Separate Bases ONLY)  
 0.23 SQ IN/FT in each direction for 48" DIA  
 0.19 SQ IN/FT in each direction for 54" DIA  
 0.35 SQ IN/FT in each direction for 72" DIA  
 0.39 SQ IN/FT in each direction for 96" DIA

Reinforcing Steel (For Precast Base and Integral Riser ONLY)  
 0.15 SQ IN/FT in each direction for 48" DIA  
 0.19 SQ IN/FT in each direction for 54" DIA  
 0.24 SQ IN/FT in each direction for 72" DIA  
 0.29 SQ IN/FT in each direction for 96" DIA

NOTES:

1. MANHOLES SHALL BE CONSTRUCTED IN ACCORDANCE WITH AASHTO M-199 UNLESS OTHERWISE SHOWN ON PLANS OR NOTED IN THE WSDOT/APWA STANDARD SPECIFICATIONS.
2. HANDHOLDS IN ADJUSTMENT SECTION SHALL HAVE 3" MINIMUM CLEARANCE. STEPS IN MANHOLE SHALL HAVE 6" MINIMUM CLEARANCE. SEE DWG. NO. 39 KCRS, "MANHOLE DETAILS."
3. ALL REINFORCED CAST-IN-PLACE CONCRETE SHALL BE CLASS A. NON-REINFORCED CONCRETE IN CHANNEL AND SHELF SHALL BE CLASS C. ALL PRECAST CONCRETE SHALL BE CLASS AX.
4. PRECAST BASES SHALL BE FURNISHED WITH CUTOUTS OR KNOCKOUTS. KNOCKOUTS SHALL HAVE A WALL THICKNESS OF 2" MINIMUM. UNUSED KNOCKOUTS NEED NOT BE GROUDED IF WALL IS LEFT INTACT. PIPES SHALL BE INSTALLED ONLY IN FACTORY KNOCKOUTS UNLESS OTHERWISE APPROVED BY THE ENGINEER.
5. KNOCKOUT OR CUTOUT HOLE SIZE SHALL EQUAL PIPE OUTER DIAMETER PLUS MANHOLE WALL THICKNESS. MAXIMUM HOLE SIZE SHALL BE 36" FOR 48" M.H., 42" FOR 54" M.H., 60" FOR 72" M.H., 84" FOR 96" M.H. MINIMUM DISTANCE BETWEEN HOLES SHALL BE 8" FOR 48" AND 54" M.H.; 12" FOR 72" AND 96" M.H.
6. MANHOLE RINGS AND COVERS SHALL BE IN ACCORDANCE WITH SEC. 7.07 KCRS AND MEET THE STRENGTH REQUIREMENTS OF FEDERAL SPECIFICATION RR-F-621D. MATING SURFACES SHALL BE FINISHED TO ASSURE NON-ROCKING FIT WITH ANY COVER POSITION.
7. ALL BASE REINFORCING STEEL SHALL HAVE A MINIMUM YIELD STRENGTH OF 60,000 PSI AND BE PLACED IN THE UPPER HALF OF THE BASE WITH 1" MINIMUM CLEARANCE.
8. FOR HEIGHTS OF 12' OR LESS, MINIMUM SOIL BEARING VALUE SHALL EQUAL 3,300 POUNDS PER SQUARE FOOT. FOR HEIGHTS OVER 12', MINIMUM SOIL BEARING VALUE SHALL EQUAL 3,800 POUNDS PER SQUARE FOOT.
9. FOR DETAILS SHOWING GRADE RING, LADDER, STEPS, HANDHOLDS AND TOP SLABS, SEE DWG. NO. 39 KCRS, "MANHOLE DETAILS."
10. SEE SEC. 7-05.3, WSDOT/APWA STANDARD SPECIFICATIONS FOR JOINT REQUIREMENTS.

(SEE WSDOT/APWA STANDARD PLAN B-23c.)

**MANHOLE TYPE 3**  
 48", 54", 72", & 96"

KING COUNTY, WASHINGTON DWG. NO. 37

NOTES:

1. MANHOLES SHALL BE CONSTRUCTED IN ACCORDANCE WITH AASHTO M-199 UNLESS OTHERWISE SHOWN ON PLANS OR NOTED IN THE WSDOT/APWA STANDARD SPECIFICATIONS.
2. HANDHOLDS IN ADJUSTMENT SECTION SHALL HAVE 3" MINIMUM CLEARANCE. STEPS IN MANHOLE SHALL HAVE 6" MINIMUM CLEARANCE. SEE DWG. NO. 39 KCRS, "MANHOLE DETAILS."
3. MANHOLE RINGS AND COVERS SHALL BE IN ACCORDANCE WITH SEC. 7.07 KCRS AND MEET THE STRENGTH REQUIREMENTS OF FEDERAL SPECIFICATION RR-F-621D. MATING SURFACES SHALL BE FINISHED TO ASSURE NON-ROCKING FIT WITH ANY COVER POSITION.
4. ALL PRECAST CONCRETE SHALL BE CLASS AX.
5. FOR DETAILS SHOWING GRADE RING, LADDER, STEPS, HANDHOLDS AND TOP SLABS, SEE DWG. NO. 39 KCRS, "MANHOLE DETAILS."

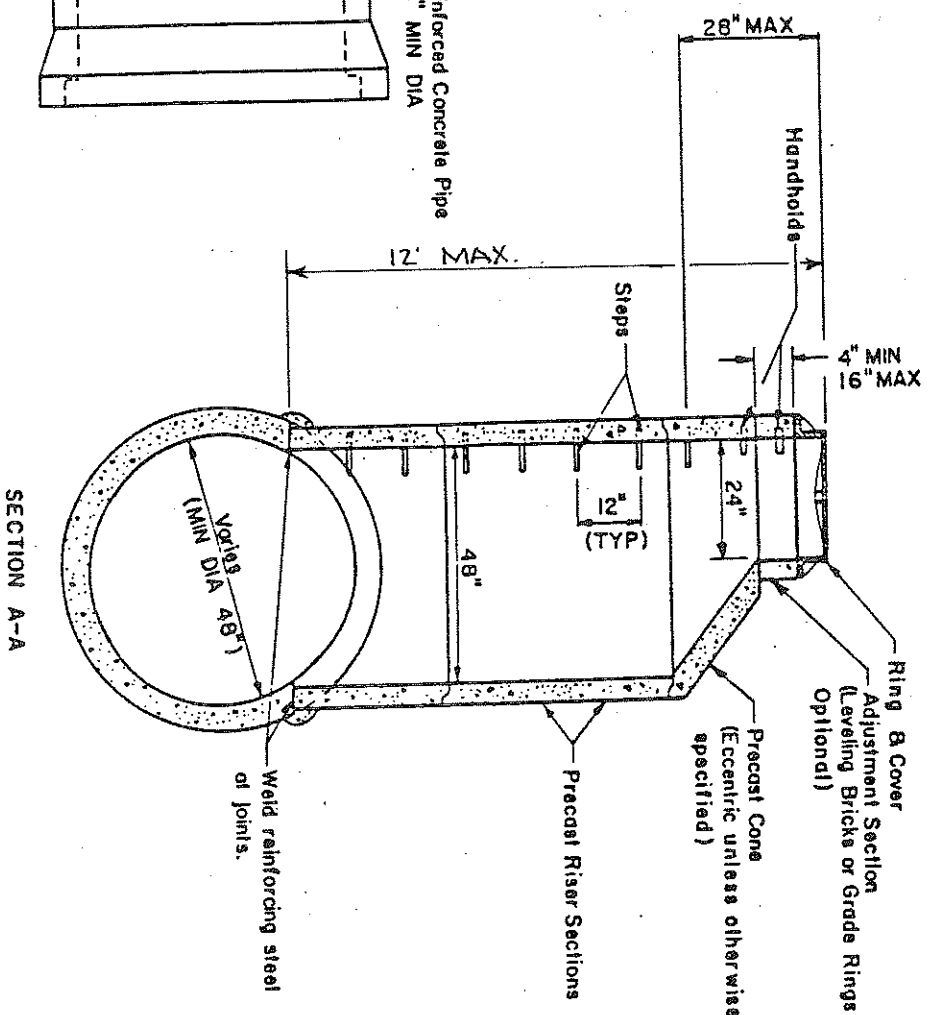
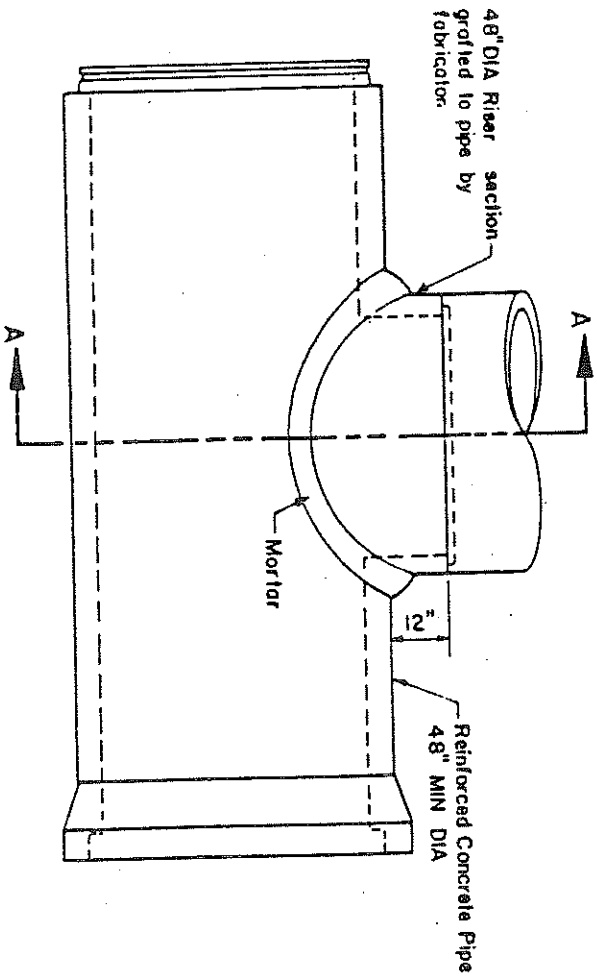

(SEE WSDOT/APWA STANDARD PLAN B-234)

MANHOLE TYPE 4

KING COUNTY, WASHINGTON	DWG. NO. 38
-------------------------	-------------

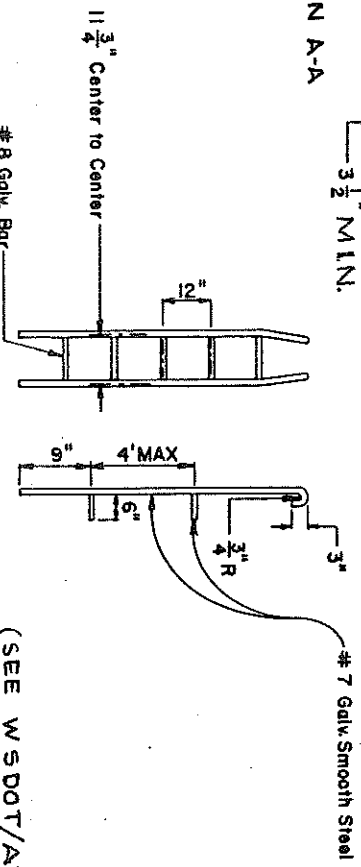
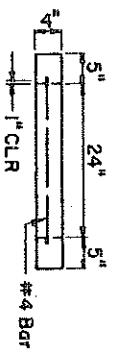
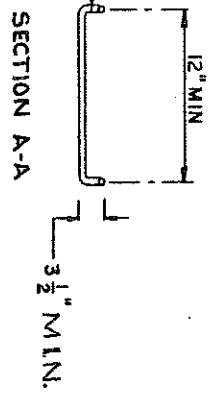
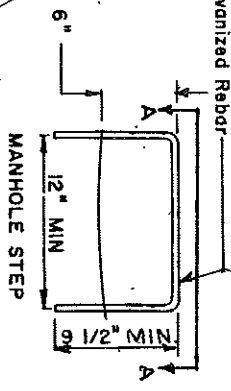
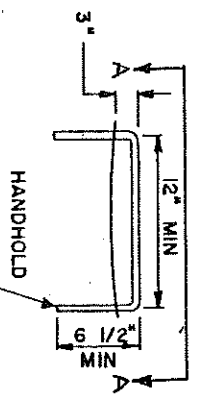
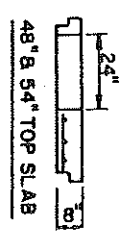
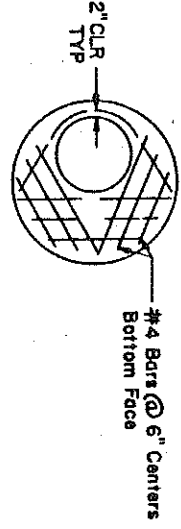
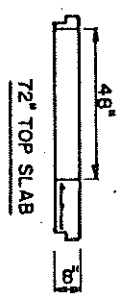
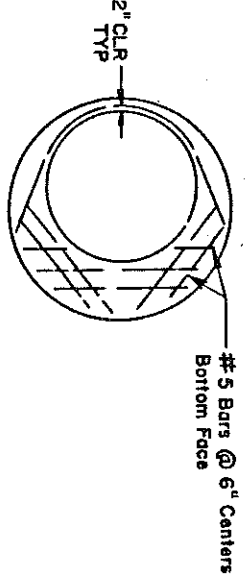
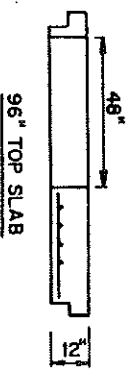
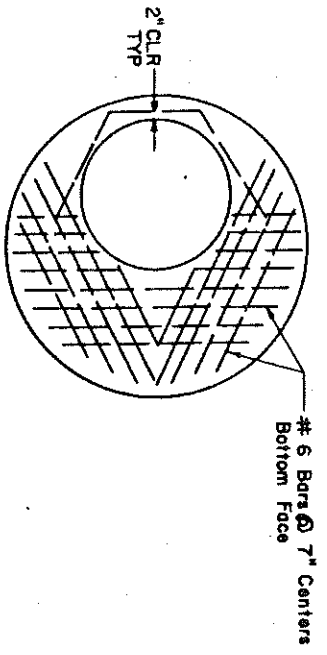

- NOTES:
1. PROPRIETARY MANHOLE HANDHOLDS AND STEPS ARE ACCEPTABLE, PROVIDED THAT THEY CONFORM TO SECTION R, AASHTO M-199 AND MEET ALL WISHA REQUIREMENTS.
  2. MANHOLE STEP/HANDHOLD LEGS SHALL BE PARALLEL OR APPROXIMATELY RADIAL AT THE OPTION OF THE MANUFACTURER, EXCEPT THAT ALL STEPS IN ANY MANHOLE SHALL BE SIMILAR. LEGS SHALL NOT PENETRATE OUTER WALL.
  3. HANDHOLDS AND STEPS SHALL HAVE "DROP" RINGS OR PROTRUSIONS TO PREVENT SIDEWAYS SLIP.
  4. LADDERS OR STEPS SHALL EXTEND TO WITHIN 16" OF BOTTOM OF MANHOLE.
  5. HANGING LADDERS SHALL BE PERMANENTLY FASTENED AT TOP BY HANGING ON STEP OR BY BOLTING OR IMBEDDING IN CONCRETE. EACH SHALL BE IMBEDDED AT BOTTOM IN BASE OR SHELF.
  6. ADDITIONAL SAFETY FEATURES MAY BE REQUIRED IN VERY DEEP OR UNUSUAL STRUCTURES.

(SEE WSDOT/APWA STANDARD PLAN B-24)

**MANHOLE DETAILS**

KING COUNTY, WASHINGTON DWG. NO. **39**

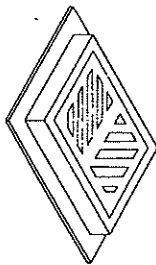

Frame and grate  
(SEE SEC 7.07 KCRS AND  
APPLICABLE DRAWINGS KCRS.

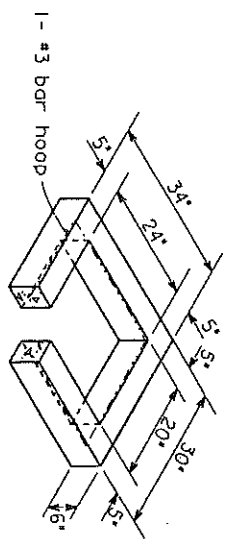

6" Riser Section

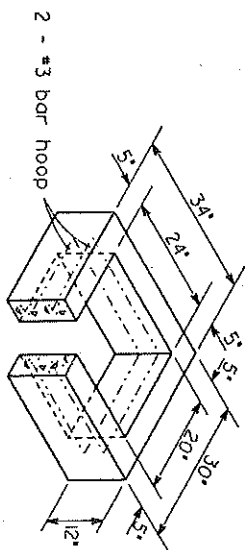

12" Riser Section

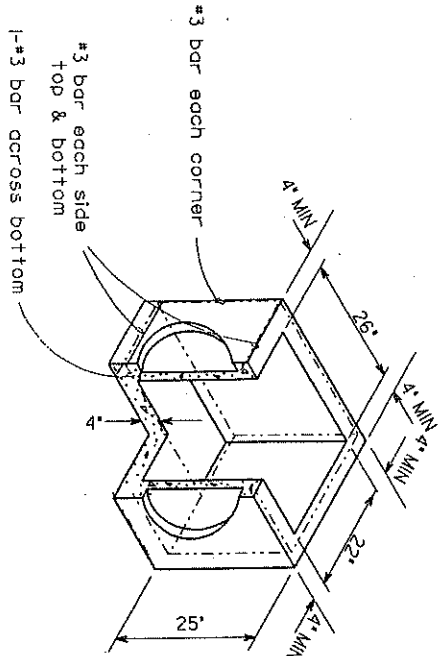

Precast Base Section  
(Measurement of the top  
of the base)

NOTES:

1. CONCRETE INLET TO BE CONSTRUCTED IN ACCORDANCE WITH ASTM C 478 & ASTM C 890 UNLESS OTHERWISE SHOWN ON PLANS OR NOTED IN THE STANDARD SPECIFICATIONS.
2. AS AN ACCEPTABLE ALTERNATE TO REBAR, WELDED WIRE FABRIC HAVING A MINIMUM AREA OF 0.12 SQUARE INCHES PER FOOT MAY BE USED. WELDED WIRE FABRIC SHALL COMPLY TO ASTM A 497.
3. ALL REINFORCED CAST IN PLACE CONCRETE SHALL BE CLASS A.
4. PRECAST BASES SHALL BE FURNISHED WITH CUTOUTS OR KNOCKOUTS SHALL HAVE A WALL THICKNESS OF 2" MINIMUM. ALL PIPE SHALL BE INSTALLED IN FACTORY PROVIDED KNOCKOUTS. UNUSED KNOCKOUTS NEED NOT BE GROUTED IF WALL IS LEFT INTACT.
5. KNOCKOUT OR CUTOUT HOLE SIZE IS EQUAL TO PIPE OUTER DIAMETER PLUS CATCH BASIN WALL THICKNESS.
6. ROUND KNOCKOUTS MAY BE ON ALL 4 SIDES WITH MAXIMUM DIAMETER OF 17".
7. THE MAXIMUM DEPTH FROM THE FINISHED GRADE TO THE PIPE INVERT IS 5'-0".
8. CONCRETE INLET FRAME AND GRATES SHALL BE IN ACCORDANCE WITH STANDARD SPECIFICATIONS AND MEET THE STRENGTH REQUIREMENTS OF FEDERAL SPECIFICATION RR-F-621D. MATTING SURFACES SHALL BE FINISHED TO ASSURE NON-ROCKING FIT WITH ANY COVER POSITION.
9. THE TAPER ON THE SIDES OF THE PRECAST BASE SECTION AND RISER SECTION SHALL NOT EXCEED 1/4"/FT.
10. FRAME AND GRATE MAY BE INSTALLED WITH FLANGE DOWN OR CAST INTO RISER.

(SEE WSDOT/APWA  
STANDARD PLAN B-2c)

**CURB INLET**

KING COUNTY,  
WASHINGTON

DWG. NO. **40**

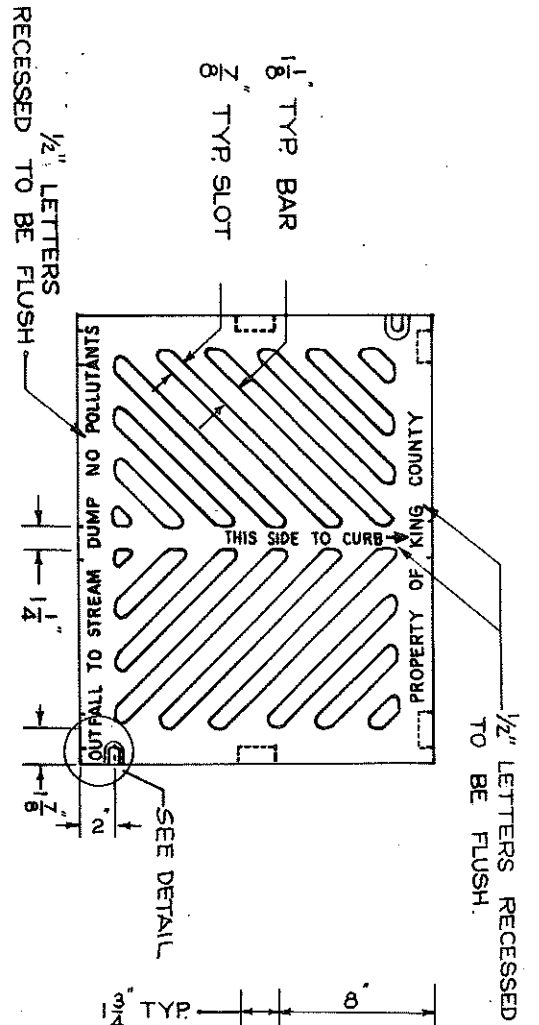

**TOP VIEW.**

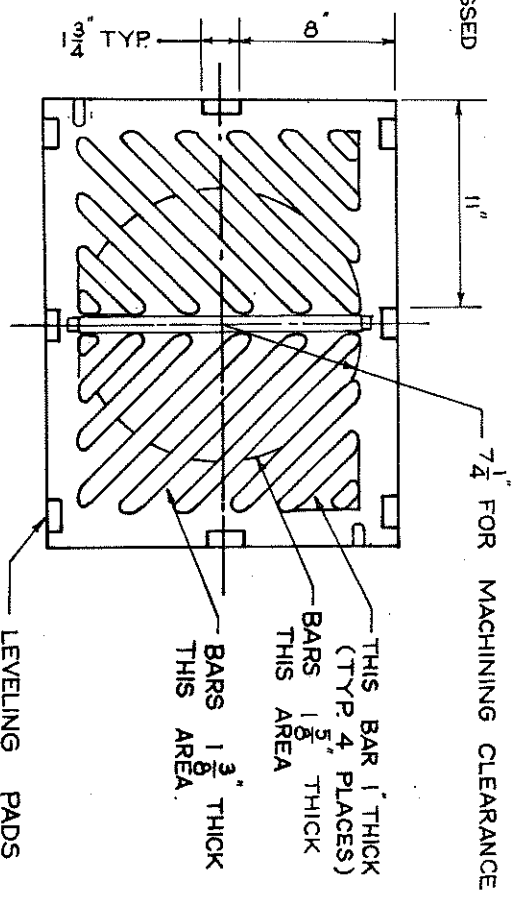

**BOTTOM VIEW.**

**SIDE VIEW.**

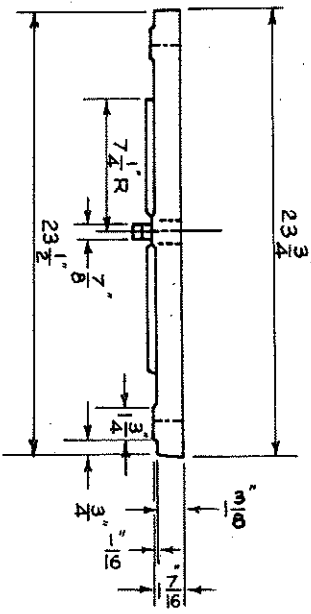

**END VIEW.**

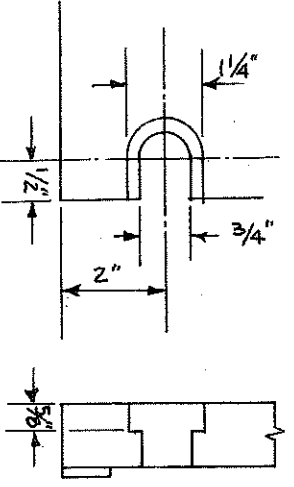
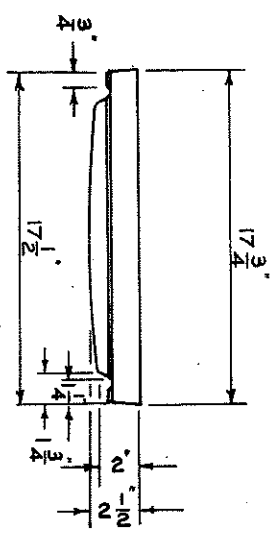

**SLOT DETAIL**  
SEE NOTE 2

- NOTES:
1. SLOT FORMED AND RECESSED FOR 5/8"-11 NC X 2" SOCKET HEAD (ALLEN HEAD) CAP SCREW.
  2. GRATE SHALL BE CAST IRON PER ASTM A48 CLASS 30 UNLESS OTHERWISE SPECIFIED.
  3. SEE SECTION 7.07 K.C.R.S.

**STANDARD GRATE**

KING COUNTY, WASHINGTON	DWG. NO. <b>41</b>
----------------------------	--------------------

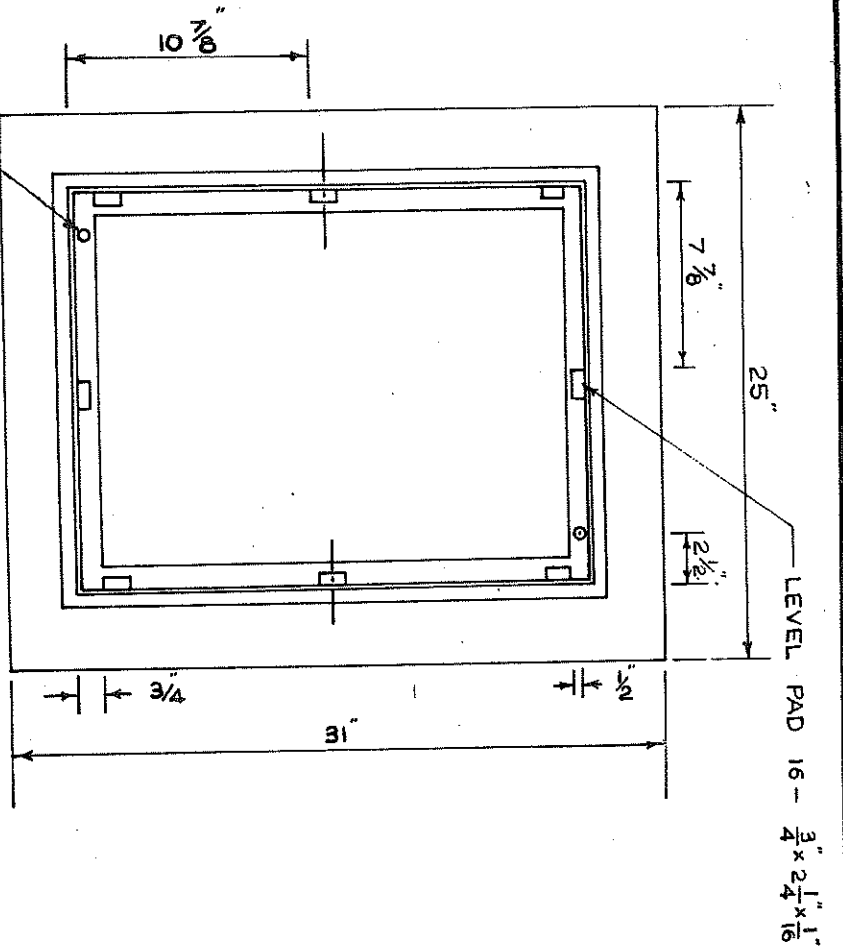

**PLAN**

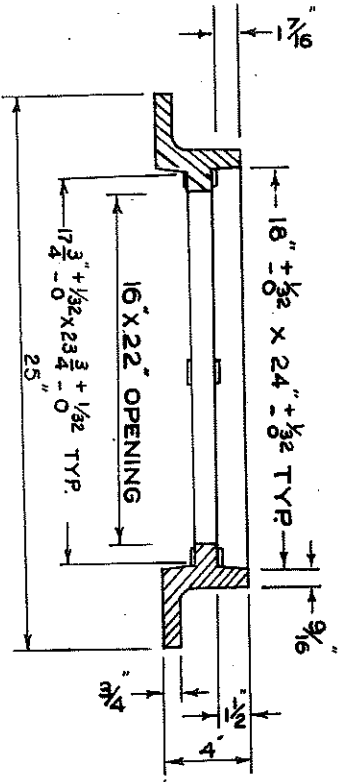

**ELEVATION.**

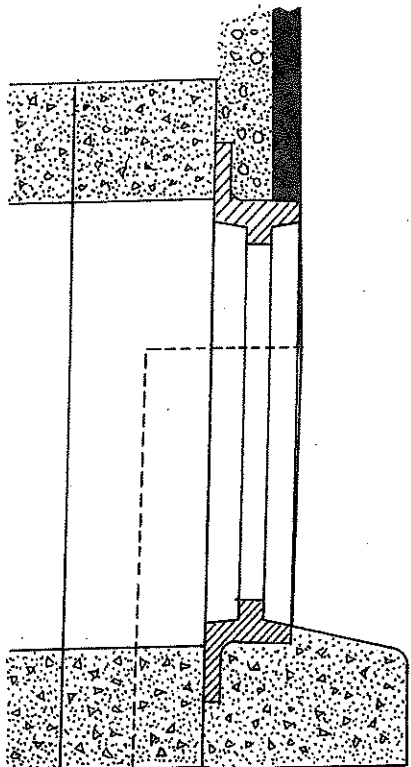

**CONSTRUCTION AT CURB**

SEE NOTE 4

**NOTES:**

1. DRILL AND TAP FOR, AND PROVIDE, TWO LOCKING BOLTS 5/8"-11 NC STAINLESS TYPE S04 STEEL SOCKET HEAD (ALLEN HEAD) CAP SCREWS 2" LONG WHEN USED WITH SOLID COVER. (DWG No. 43) OR WHEN SPECIFIED BY ENGINEER.
2. FRAME MATERIAL IS CAST IRON PER ASTM A-48 CLASS 30.
3. SET FRAME TO GRADE AND CONSTRUCT ROAD AND GUTTER TO BE FLUSH WITH FRAME.
4. SEE SEC. 7.07 K.C.R.S.

**STANDARD FRAME WITH  
VERTICAL CURB INSTALLATION**

KING COUNTY  
WASHINGTON

DWG. NO. **42**

- NOTES:
1. USE WITH FRAME (DWG. No 42). DRILLED AND TAPPED FOR LOCKING BOLTS.
  2. USE WITH TWO LOCKING BOLTS  $\frac{5}{8}$ "-11NC STAINLESS TYPE 304 STEEL SOCKET HEAD (ALLEN HEAD) CAP SCREWS, 2" LONG.
  3. MATERIAL IS CAST IRON PER ASTM A48 CLASS 30.
  4. SEE SECTION 7.07 KCRS.

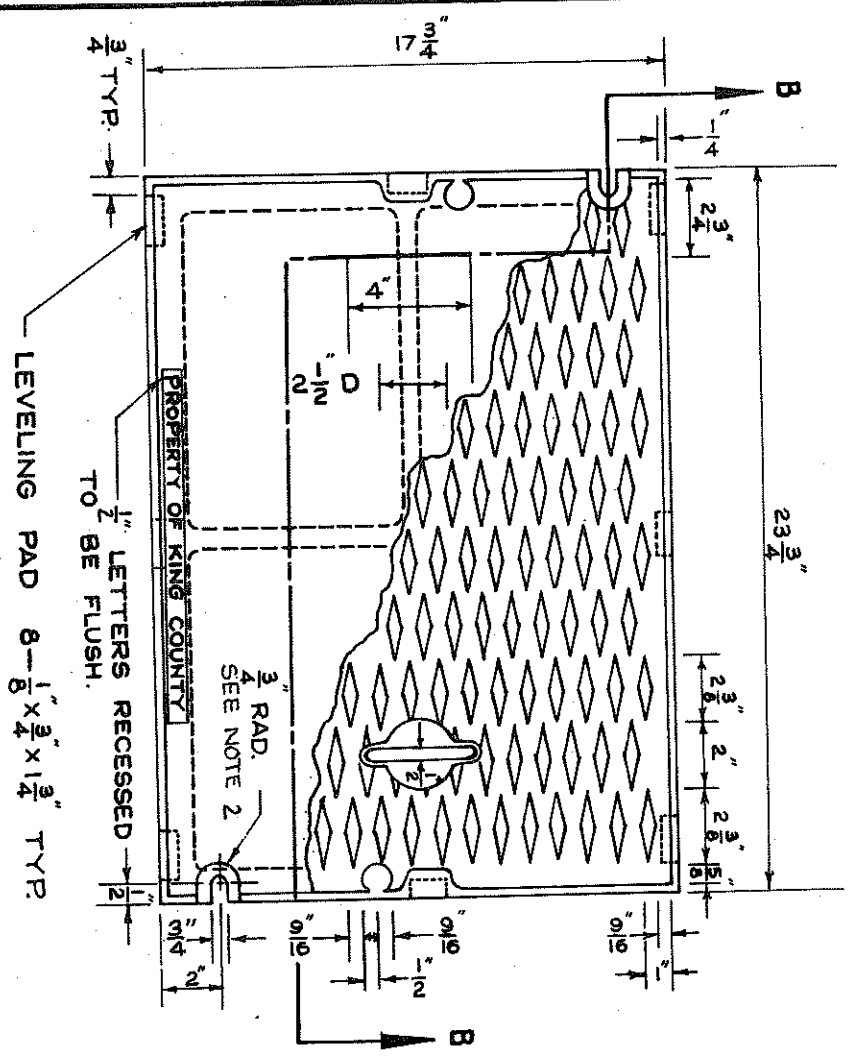

COVER ESTIMATED WT. 92

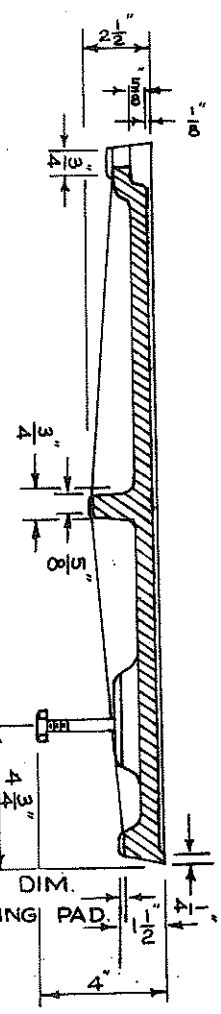

SECTION B-B

FINISH DIM. ON LEVELING PAD.

SOLID COVER	
KING COUNTY, WASHINGTON	DWG. NO. 43

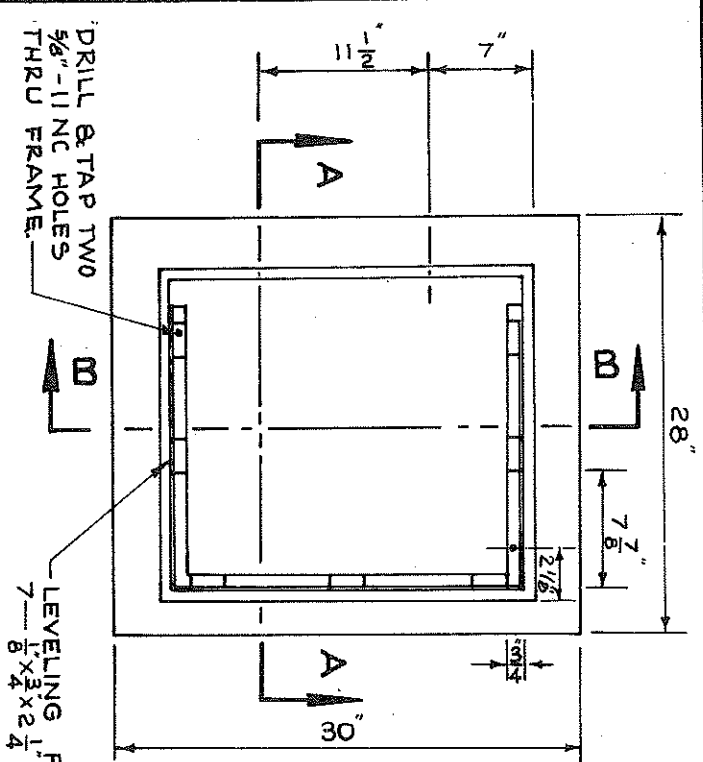

PLAN VIEW.

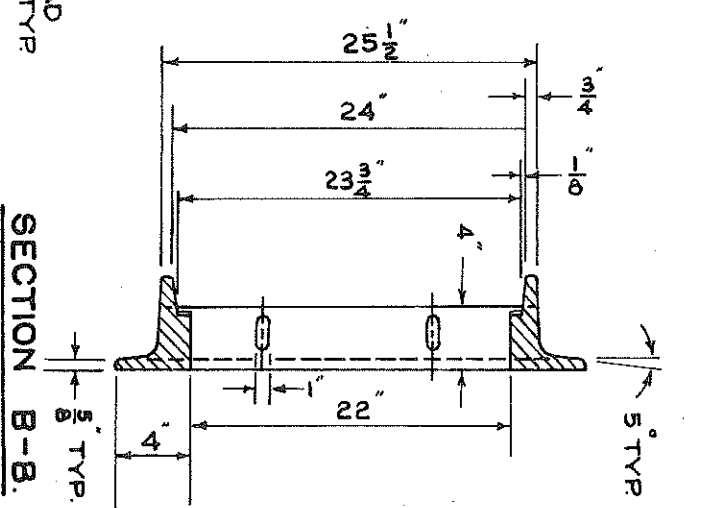

SECTION B-B.

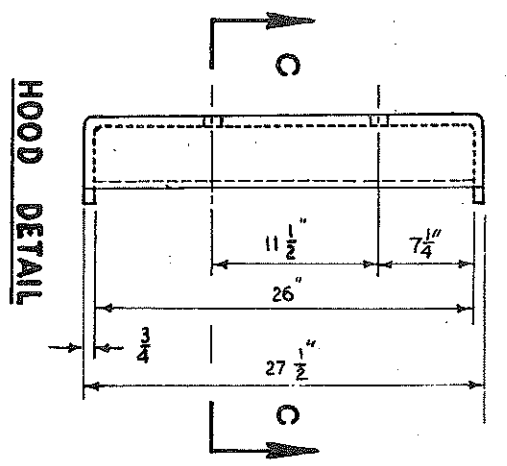

HOOD DETAIL

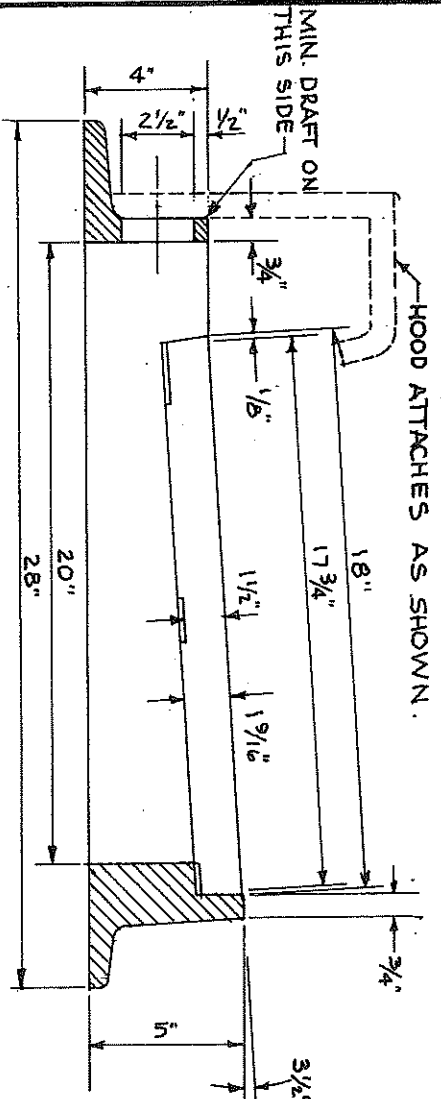

SECTION A-A.

2-1" DIA. HOLES, FOR 3/4" BOLT, WASHER, & NUT. SEE NOTE 4.

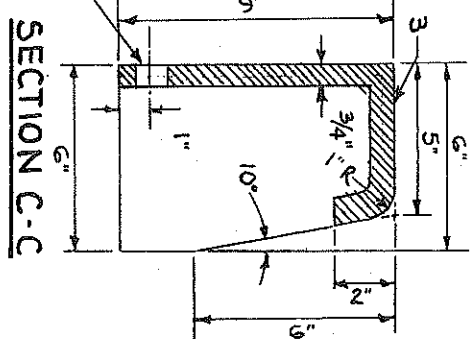

SECTION C-C

- NOTES:
1. EST. 365#, USE CAST IRON ASTM A48 CL.30.
  2. USE VANED GRATE IN DUCTILE IRON AS SHOWN ON DWG No 46 KCRS.
  3. MAKE 3/16" NON-SKID DIAMOND PATTERN ON TOP SURFACE.
  4. BOLT, WASHER, AND NUT SHALL BE GALV. OR CORROSION RESISTANT.
  5. SEE SEC. 7.07 KCRS.

THROUGH-CURB INLET FRAME

KING COUNTY, WASHINGTON  
 DWG. NO. 44

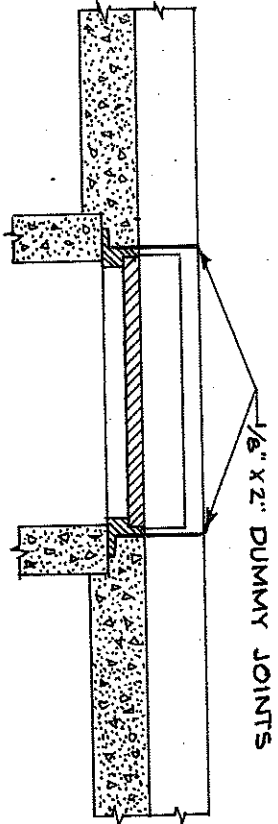
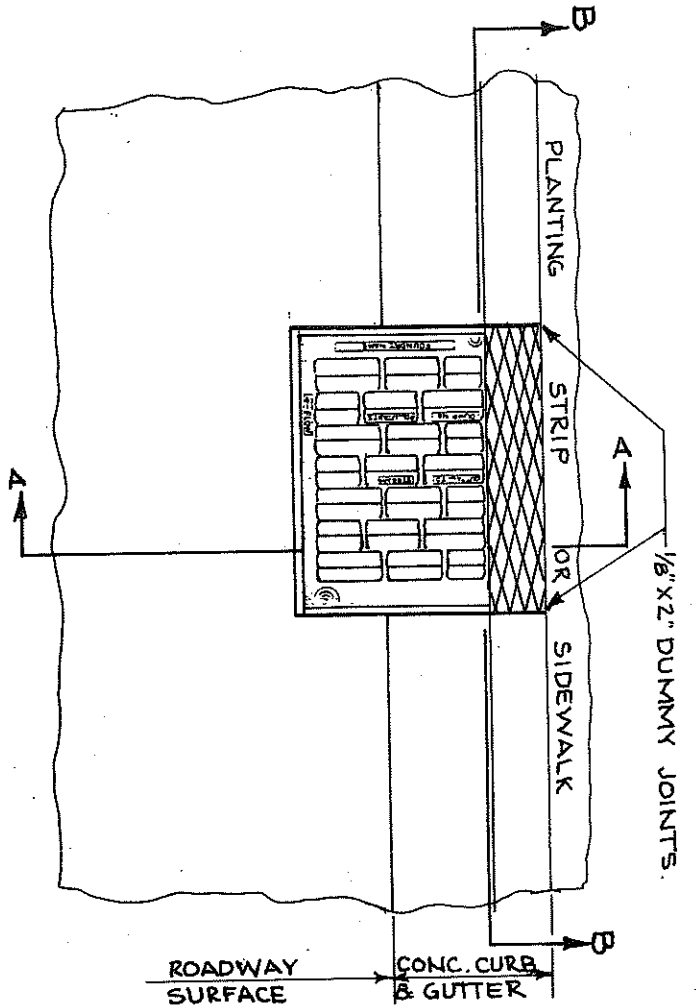

**SECTION B-B**

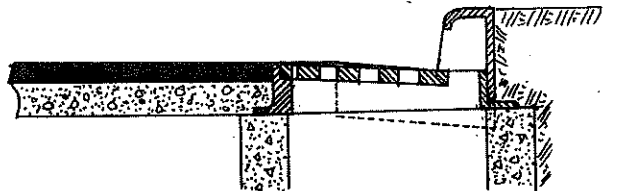

**SECTION A-A**

**NOTE:**  
 SET TO GRADE AND CONSTRUCT  
 ROAD AND GUTTER TO BE  
 FLUSH WITH FRAME.

**THROUGH-CURB INLET FRAME  
 & GRATE WITH  
 VERTICAL CURB INSTALLATION**

KING COUNTY,  
 WASHINGTON

DWG. NO. **45**

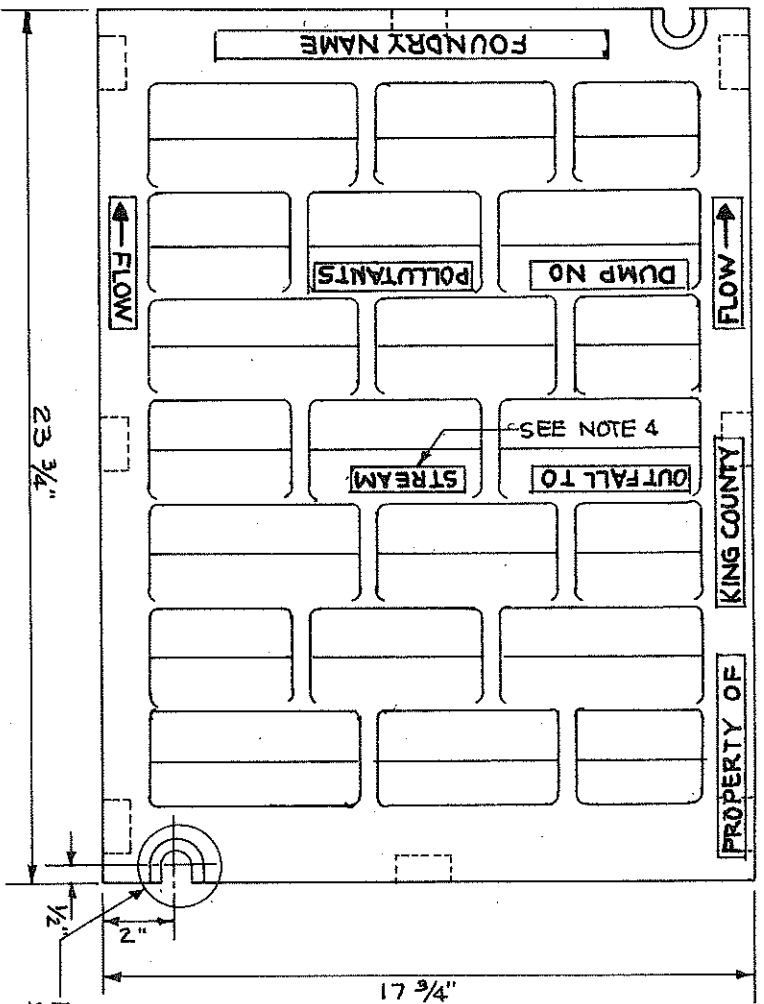

FOR SLOT DETAIL  
SEE DWG. No 41 KCRS.

- NOTES:
1. OLYMPIC FOUNDRIY SELF-LOCK VANED GRATE SM50SL IS ACCEPTABLE ALTERNATIVE SUBJECT TO APPROVAL BY ENGINEER.
  2. USE WITH TWO LOCKING BOLTS 3/8" - 11NC STAINLESS TYPE 304 STEEL SOCKET HEAD (ALLEN HEAD) CAP SCREWS 2" LONG, IF SPECIFIED. NOTE SLOT DETAIL.
  3. MATERIAL IS DUCTILE IRON ASTM A536 GRADE 80-55-06.
  4. "OUTFALL TO STREAM DUMP NO POLLUTANTS" MAY BE LOCATED ON BORDER AREA.
  5. SEE SECTION 7.07 K.C.R.S.

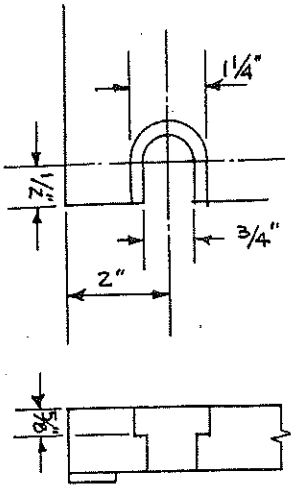
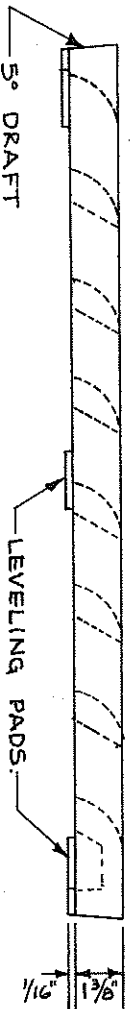

SLOT DETAIL  
SEE NOTE 2

VANED GRATE	
KING COUNTY, WASHINGTON	DWG. NO. 46

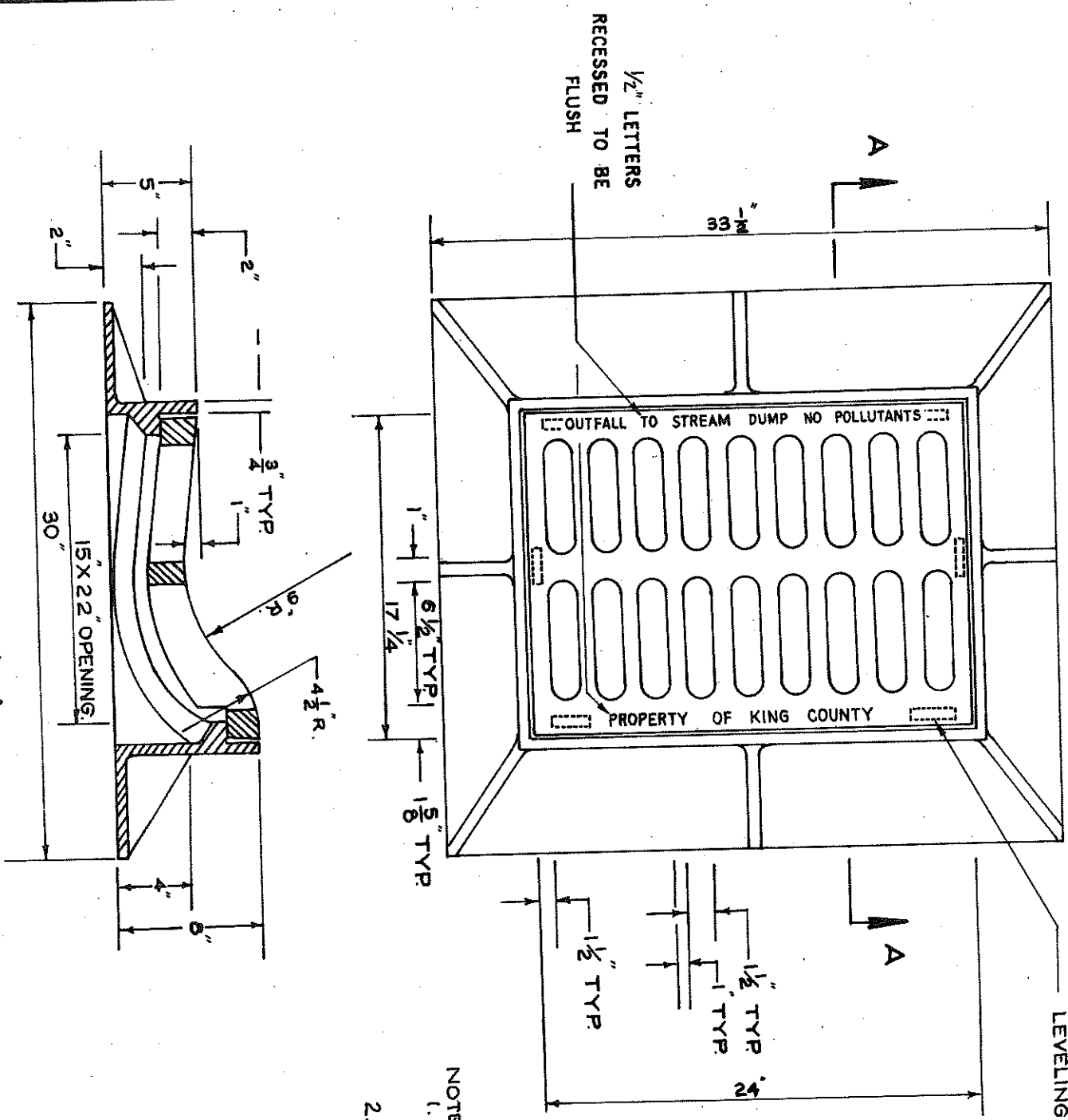

LEVELING PAD 8- $\frac{3}{4}$  x 2 $\frac{1}{4}$  x  $\frac{1}{16}$

$\frac{1}{2}$ " LETTERS  
RECESSED TO BE  
FLUSH

SECTION A A

- NOTES:  
 1. MATERIAL IS CAST IRON ASTM A48 CLASS 30.  
 2. SEE SECTION 7.07 KCRS.

ROLLED CURB FRAME  
 & GRATE

KING COUNTY,  
 WASHINGTON

DWG. NO. 47

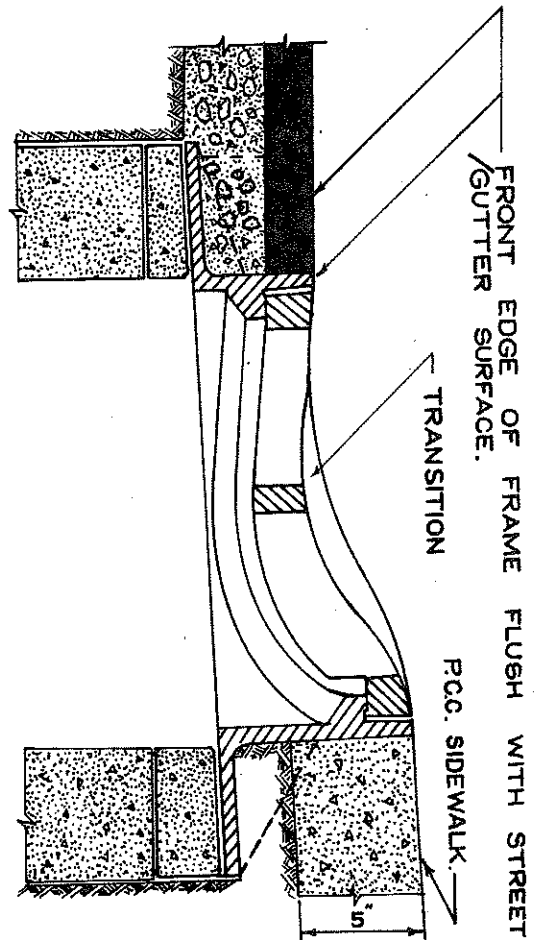
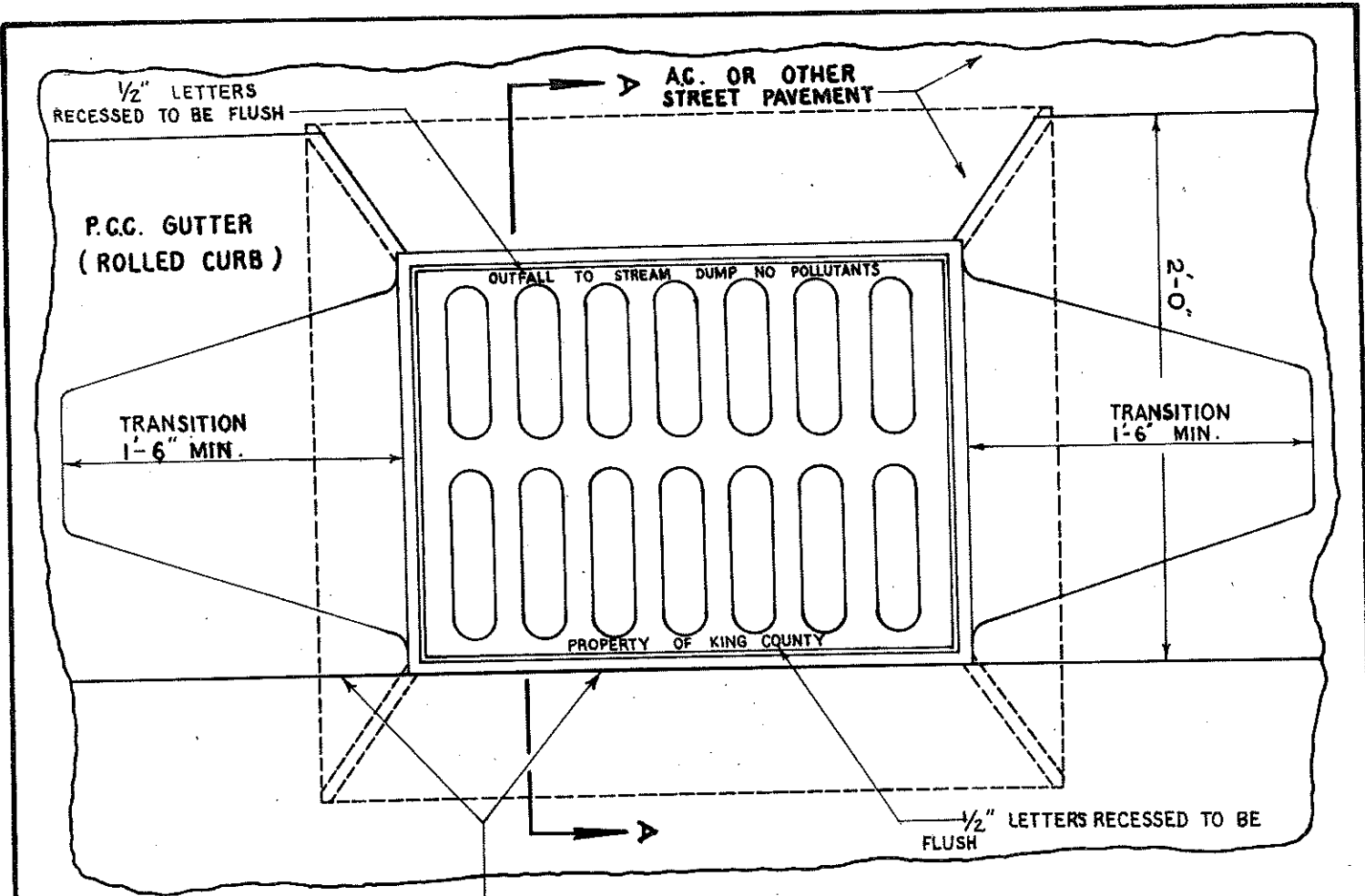

SECTION A-A

BACK EDGE OF FRAME EVEN WITH BACK FACE OF CURB.

NOTES:

1. SET FRAME TO GRADE AND CONSTRUCT ROAD AND CURB TO BE FLUSH AT FRONT AND BACK OF FRAME
2. SEE SECTION 7.07 KCGRS

ROLLED CURB FRAME & GRATE INSTALLATION

KING COUNTY, WASHINGTON DWG. NO. 48

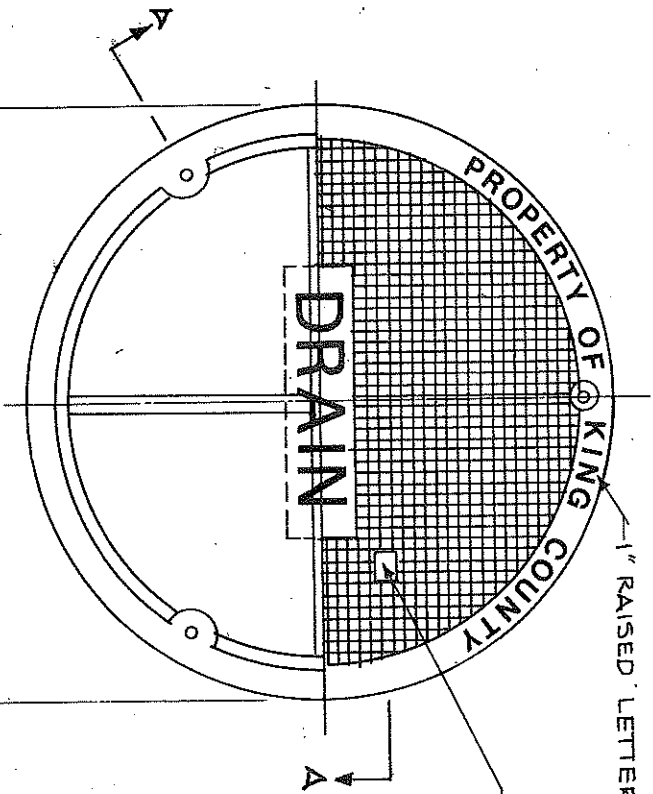

**SECTION A-A**

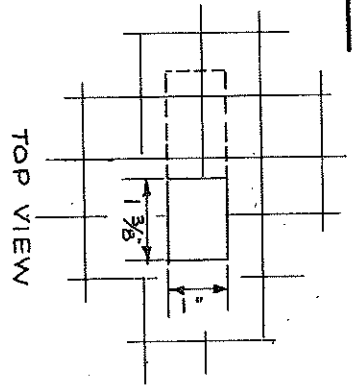
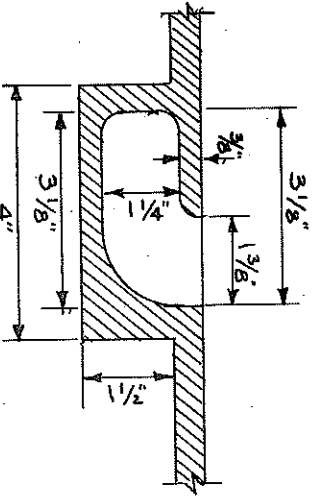
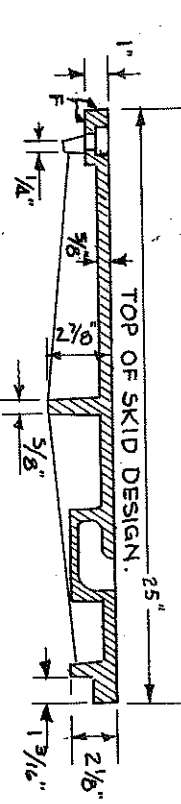

**BLIND PICK NOTCH DETAIL**

BLIND PICK NOTCH.

**COVER SKID DESIGN DETAIL**

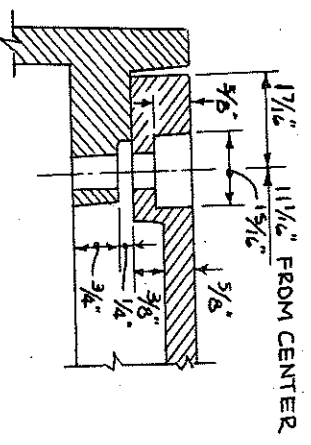
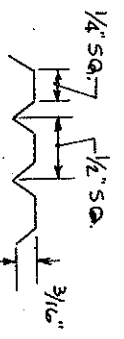

**BOLT-DOWN DETAIL**

- NOTES**
1. USE WITH THREE LOCKING BOLTS 3/8" - 11 NC STAINLESS TYPE 304 STEEL SOCKET HEAD (ALLEN HEAD) CAP SCREWS 2" LONG. DRILL HOLES SPACED 120° AT 11 1/2" RADIUS.
  2. MATERIAL IS DUCTILE IRON ASTM A 53C GRADE 80-55-06.
  3. SEE SECTION 7.07 K.C.R.S.

**LOCKING MANHOLE COVER**

KING COUNTY WASHINGTON	DWG. NO. 49
---------------------------	----------------

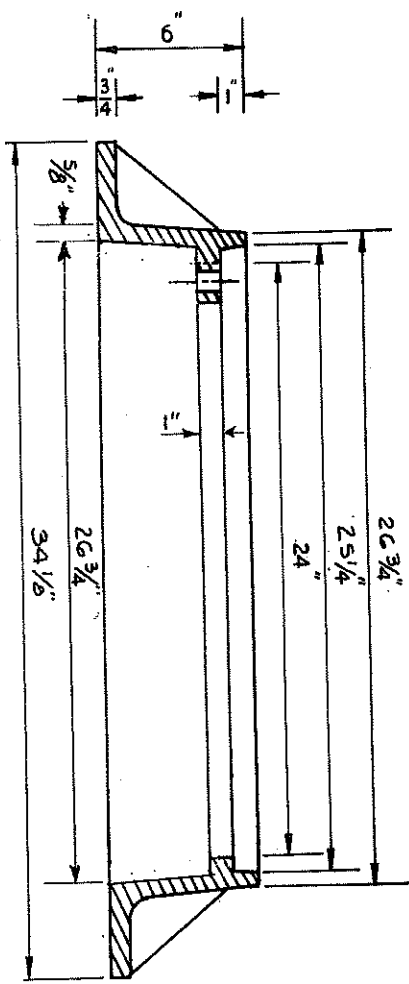
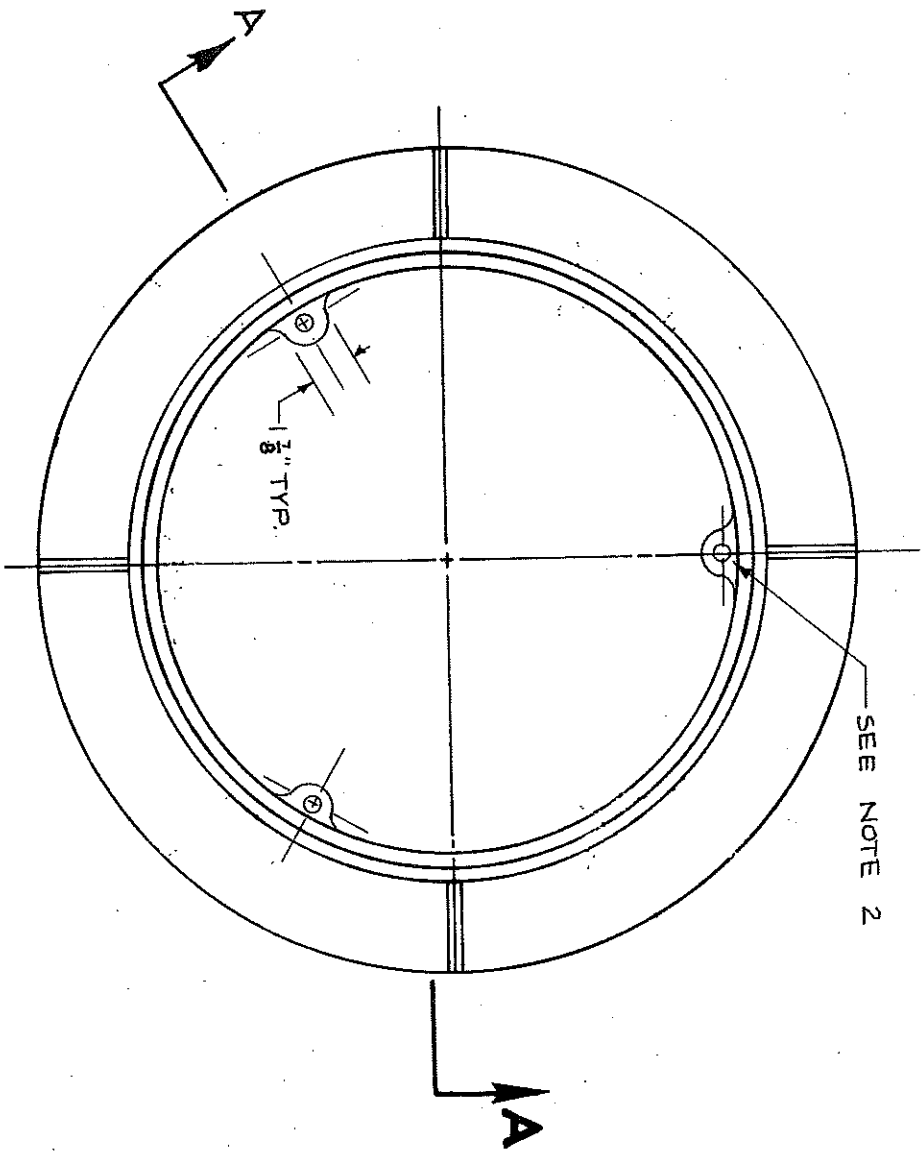

**SECTION A--A**

SEE NOTE 2

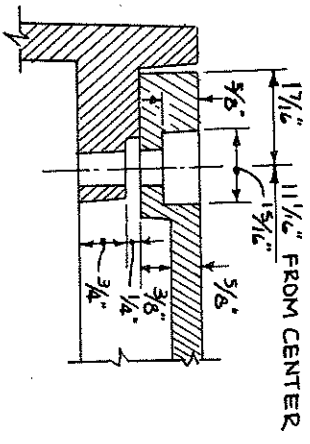

**BOLT-DOWN DETAIL**

- NOTES:
1. MATERIAL IS CAST IRON ASTM A-40 CLASS 30.
  2. DRILL AND TAP THREE 5/8"-11 NC HOLES THRU FRAME AT 120° AND 11 1/6" RADIUS.
  3. SEE SECTION 7.07. K.C.R.S.

**LOCKING MANHOLE FRAME**

KING COUNTY WASHINGTON	DWG. NO. <b>50</b>
---------------------------	-----------------------

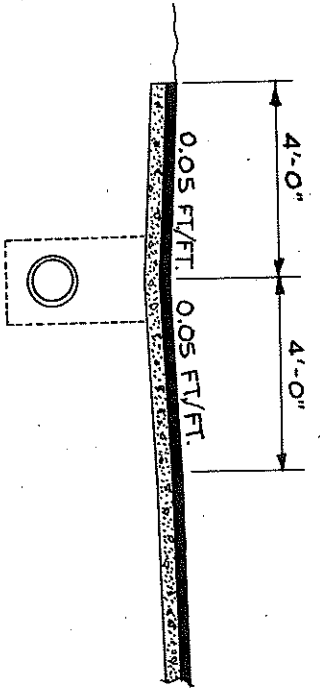
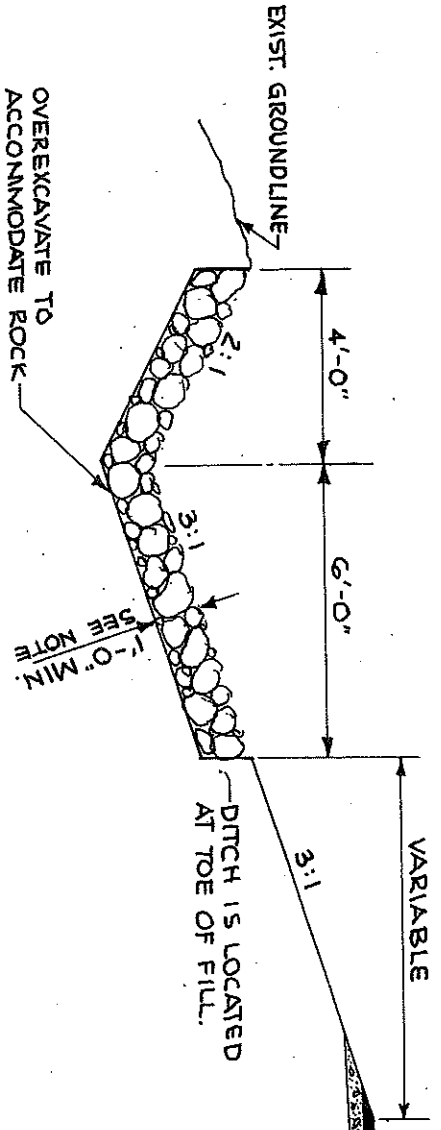
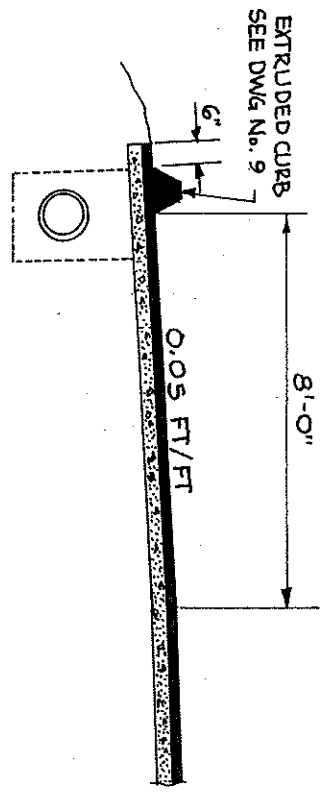
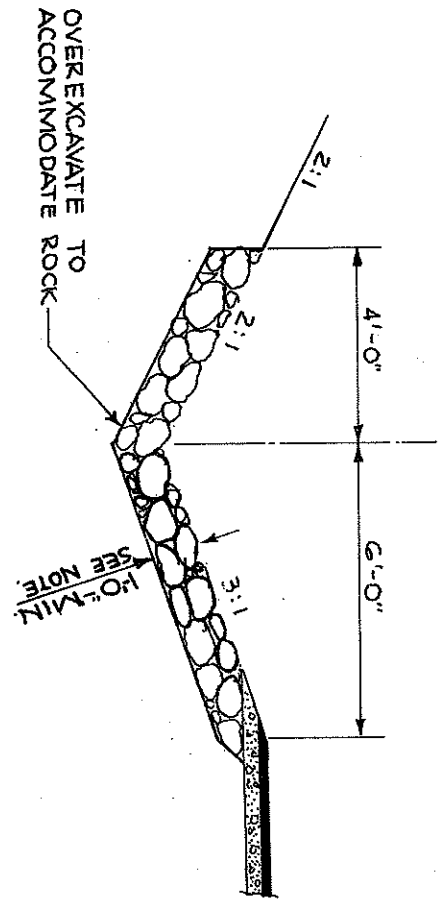

**ROCK-LINED SHOULDER DITCH  
IN CUT SECTION**

**CURBED SHOULDER**

**ROCK-LINED SHOULDER DITCH  
IN FILL SECTION**

**TURNPIKE SHOULDER**

NOTES:  
1. DEEPER ROCK FILL MAY  
BE SPECIFIED.

2. SEE SECTION 7.02 KCRS

**ROCK-LINED SHOULDER DITCHES  
& CURBED OR TURNPIKE SHOULDERS**

KING COUNTY,  
WASHINGTON

DWG. NO. 51



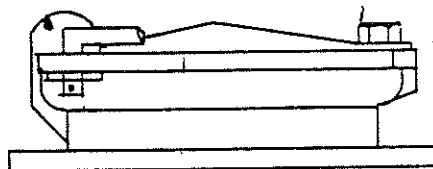
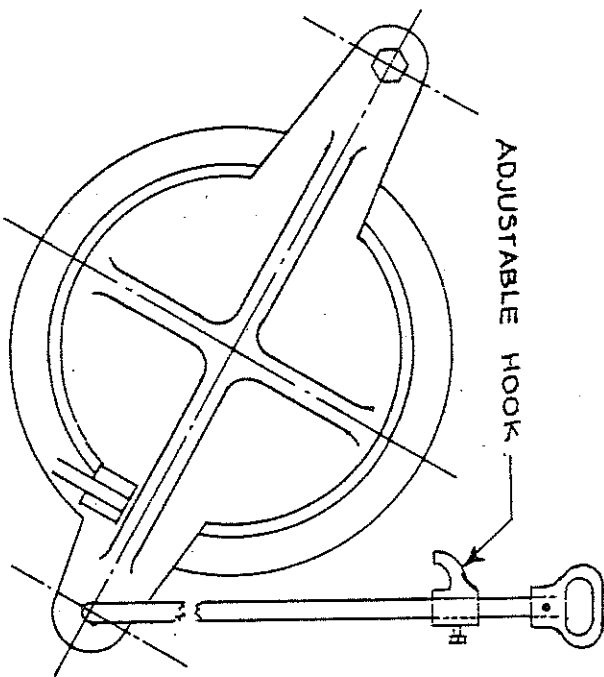

FLANGED END

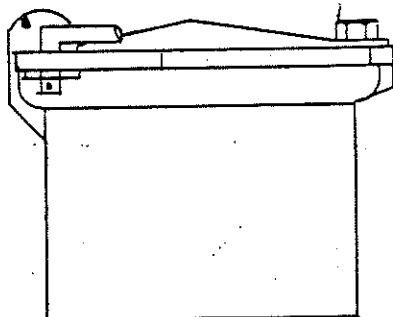

SPIGOT END

NOTES:

1. SHEAR GATE SHALL BE
  - A. SHEAR GATE, CAST IRON BODY AND GATE, OLYMPIC FDY. STD. OR EQUAL. OR
  - B. SHEAR GATE ALUMINUM OR CAST IRON, DRAINAGE SPECIALTIES (SAVANNAH, GA) STD. OR EQUAL.
2. GATE SHALL BE 8" DIAM. UNLESS OTHERWISE SPECIFIED.
3. GATE SHALL BE JOINED TO TEE SECTION BY BOLTING (THROUGH FLANGE), WELDING, OR OTHER SECURE MEANS.
4. LIFT ROD: AS SPECIFIED BY MFR. WITH HANDLE EXTENDING TO WITHIN ONE FOOT OF COVER AND ADJUSTABLE HOOK LOCK FASTENED TO FRAME OR UPPER HANDHOLD.

FRP-T SHEAR GATE DETAIL

KING COUNTY,  
WASHINGTON

DWG. NO. 53

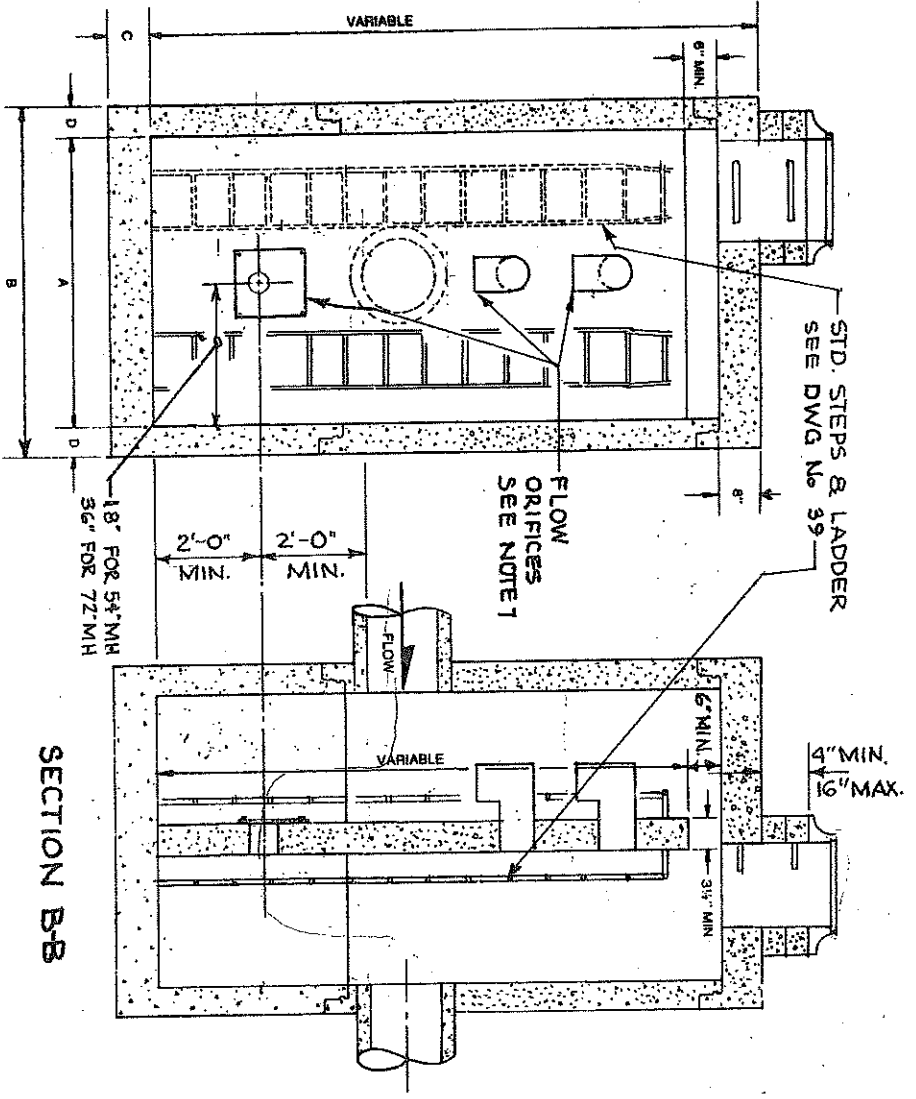

**SECTION A-A**

**SECTION B-B**

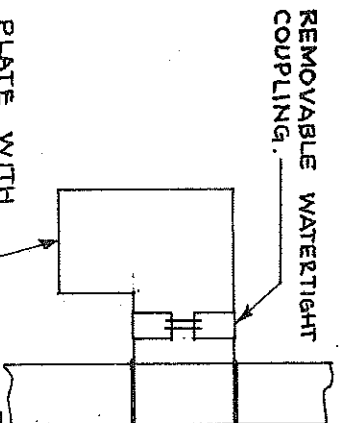

**ELBOW DETAIL**

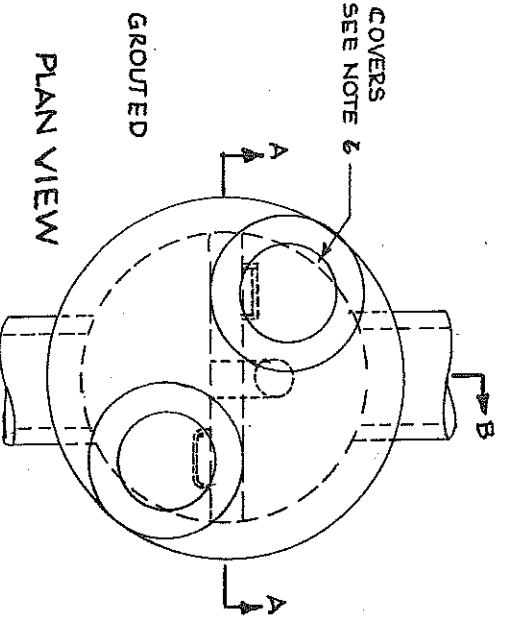
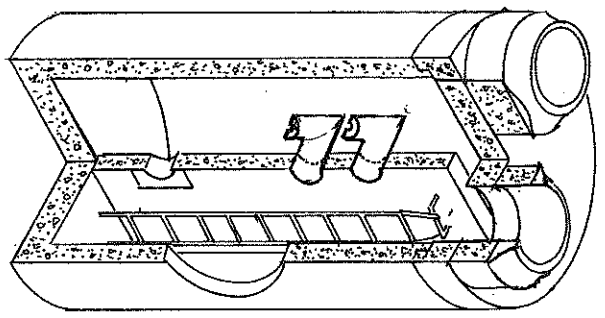

**PLAN VIEW**

**FLOW RESTRICTOR/OIL POLLUTION CONTROL DEVICE, BAFFLE TYPE (FROP-B)**

KING COUNTY, WASHINGTON  
 DWG. NO. **54**

**NOTES:**

1. SEE SURFACE WATER MGMT. DIV. BULLETIN "MULTIPLE ORIFICES" EFF. SEPT. 1, 1985.
2. PIPE SIZES AND SLOPES AND ALL ELEVATIONS: PER PLANS.
3. OUTLET CAPACITY: NOT LESS THAN COMBINED INLETS.
4. METAL PARTS: CORROSION RESISTANT, STEEL PARTS GALVANIZED.
5. CATCH BASIN: TYPE 2, TO BE CONSTRUCTED IN ACCORDANCE WITH DWG. NO. 33 AND ASHTO M-199 UNLESS OTHERWISE SPECIFIED.
6. COVERS: ROUND, SOLID MARKED "DRAIN," WITH LOCKING BOLTS. SEE DWGS. NO. 49 & 50.
7. ORIFICES: SIZED AND LOCATED AS REQUIRED, WITH LOWEST ORIFICE MIN. 2' FROM BASE.