

Residential Energy and Ventilation Summary

Applicant: _____ Parcel: _____ Permit Number: _____

Check the box adjacent to applicable options given or fill-in the blanks.

Job Type: New Dwelling ___ Addition ___ Addition and Remodel ___ Remodel ___ Square Ft. _____

Heating Fuel: Gas ___ Electric ___ Oil ___ Propane ___ Other: _____ Size: _____ Btuh / KW

Heating system: Forced Air ___ Wall or baseboard units ___ Radiant in-floor ___ Hydronic ___

Heat Pump ___ Ductless Heat Pump ___ Mini-split Heat pump ___ Existing system ___ Other: _____

Prescriptive compliance: Zone 4 Marine (wood-framed buildings) R402.1

Openings ^a U-Values		Ceiling Insulation		Walls ^a	Below Grade Walls ^c		Floors	Slab on grade	
% floor area	Vertical	Overhead	attic	vaulted ^b	Above Grade	interior			exterior
Unlimited	0.30 <i>EC 1d: 0.24</i>	0.50	R-49 or R-38 ADV	R-38	R-21 Int.	R-21 Int.w/ thermal break	R-10	R-30	R-10
<i>NOTE: Energy credit options may affect the component's values</i>									
<i>EC option 1a</i>	0.28	0.50	""	""	""	""	""	R-38	R-10 Full
<i>EC option 1b</i>	0.25	0.50	""	""	R21+R4ci	R21+R5ci	""	R-38	R-10 Full
<i>EC option</i>	0.22	0.50	R-49 ADV	R-49	R21+R12ci	R21+R12ci	""	R-38	R-10 Full

footnote a: openings includes all windows and doors. Intermediate framing requires headers to be insulated

footnote b: applicable only to single joist or rafter cavity, not scissor trusses

footnote c: R-21 equivalent may be R-15 interior rigid continuous insulation (ci), OR R-13 batt interior with R-5 rigid continuous insulation (ci)

U-Factor / Total UA Equivalent compliance (fill-in proposed values)

	Openings	U-value		Ceiling Insulation		Walls	Below Grade Walls		Floors	Slab on grade
	% floor area	Vertical	Overhead	attic	vaulted	Above	interior	exterior		
Target Values	15%	0.300	0.50	0.026	0.026	0.056	0.042	0.042	0.029	0.54
Proposed Values										
Equivalent Insulation R-values:										

WHOLE HOUSE VENTILATION SYSTEM ventilation rate per Table M1507.3.3(1) / (2)

- ___ Exhaust fan with 24-hr timer and fresh air inlets in each habitable room per IRC M1507.3.4
- ___ Integrated with forced air system per IRC M1507.3.5
- ___ Supply fan per IRC M1507.3.6
- ___ Heat Recovery system per IRC M1507.3.7
- ___ Engineered design in compliance with IMC section 403.8.10.
- ___ Exempt: Addition less than 500 sq.ft. or Remodel only.

Specify location of Whole House Fan: _____ Size: _____ cfm _____ hrs./day

Residential Energy and Ventilation Compliance Summary, continued

ENERGY CREDIT OPTION DESCRIPTIONS: Choose option(s) for total points equal to minimum required for project size: Addition < 500 sq.ft. = 0.5 pts.; Addition > 500 sq.ft. and Addition < 1500 sq.ft. = 1.5 pts.; Bldg sq.ft. < 1500 with less than 300 sq.ft. openings = 1.5 pts.; Bldg sq.ft. > 5000= 4.5 pts.; All others = 3.5 pts. Remodels <u>only</u> are exempt from energy credit options.	
<input type="checkbox"/> 1a (0.5 pt)	Efficient Building Envelope 1a: Table R402.1.1 Prescriptive compliance with openings U = 0.28, floor R-38, slabs R-10 perimeter and under entire slab, OR Total UA Equivalent compliance Target UA reduced by 5% (0.5 pt)
<input type="checkbox"/> 1b (1.0 pt)	Efficient Building Envelope 1b: Table R402.1.1 Prescriptive compliance with openings U = 0.25, wall R-21 plus R-4, floor R-38, slabs R-10 perimeter and under entire slab with below grade walls R-21 plus R-5 c.i., OR Total UA Equivalent compliance with Target UA reduced by 15%. (1.0pt)
<input type="checkbox"/> 1c (2.0 pts)	Efficient Building Envelope 1c: Table R402.1.1 Prescriptive compliance with openings U = 0.22, walls R-21 plus R-12 c.i., floor R-38, slabs R-10 perimeter and under entire slab, and R-49 advanced frame ceilings and vaulted areas, OR Total UA Equivalent compliance with Target UA reduced by 30%. (2.0pts)
<input type="checkbox"/> 1d (0.5 pt)	Efficient Building Envelope 1d: Table R402.1.1 Prescriptive compliance with openings U = 0.24 (0.5 pt)
<input type="checkbox"/> 2a (0.5 pt)	Air leakage Control and Efficient Ventilation 2a: Compliance per R402.4.1.2: Envelope leakage reduced to maximum 3.0 ACH . Whole house ventilation requirements met by ventilation system per IRC M1507.3 with high efficiency fan (maximum 0.35 watts/cfm) not interlocked with furnace ventilation system. (0.5 pt)
<input type="checkbox"/> 2b (1.0 pt)	Air leakage Control and Efficient Ventilation 2b: Compliance per R402.4.1.2: Envelope leakage reduced to maximum 2.0 ACH . Whole house ventilation requirements met by heat recovery system per IRC M1507.3 with minimum sensible heat recovery efficiency of 0.70. (1.0 pt) Show heat recovery system
<input type="checkbox"/> 2c (1.5 pts)	Air leakage Control and Efficient Ventilation 2c: Compliance per R402.4.1.2: Envelope leakage reduced to maximum 1.5 ACH . Whole house ventilation requirements met by heat recovery system per IRC M1507.3 with minimum sensible heat recovery efficiency of 0.85. (1.5 pts) Show heat recovery system
<input type="checkbox"/> 3a (1.0 pt)	High Efficiency HVAC Equipment 3a: Gas, propane, or oil-fired <u>furnace</u> with minimum AFUE of 94% or boiler with minimum AFUE of 92%. Plans shall specify equipment type, size, and minimum efficiency.
<input type="checkbox"/> 3b (1.0 pt)	High Efficiency HVAC Equipment 3b: Air-source heat pump with minimum HSPF of 9.0. Plans shall specify heating equipment type, size, and minimum efficiency. (1.0 pt)
<input type="checkbox"/> 3c (1.5 pts)	High Efficiency HVAC Equipment 3c: Closed-loop ground source heat pump with minimum COP of 3.3 OR open-loop water source heat pump with maximum pumping hydraulic head of 150 ft. and with COP ≥ 3.6. Plans shall specify heating equipment type, size, and minimum efficiency. (1.5 pts)
<input type="checkbox"/> 3d (1.0 pt)	High Efficiency HVAC Equipment 3d: Where primary space heating system is zonal electric heating , a ductless heat pump system shall be installed to provide heating to the largest zone . (1.0 pt)
<input type="checkbox"/> 4 (1.0 pt)	High Efficiency HVAC Distribution: All heating and cooling components installed inside conditioned space. All combustion equipment shall be direct vent or sealed combustion. No system components installed in crawlspace. Duct type and length limitations and insulated to minimum R-8 if located outside conditioned space No electric resistance heat or ductless heat pumps are permitted. Direct combustion heating equipment AFUE ≥80%. show equipment type and location of all equipment and type of ductwork.
<input type="checkbox"/> 5a (0.5 pt)	Efficient Water Heating 5a: All showerheads and kitchen sink faucets shall be rated at 1.75 gpm or less, all others at 1.0 gpm or less when tested in accordance with ASME A112.18.1/CSA B125.1. (0.5 pt)
<input type="checkbox"/> 5b (1.0 pt)	Efficient Water Heating 5b: Water heating system shall include one of the following: gas, propane or oil water heater with minimum EF of 0.74; OR water heater heated by ground source heat pump with minimum COP of 3.3 OR open-loop water source heat pump with maximum pumping hydraulic head of 150 ft. and with COP > 3.6. Plans shall specify heating equipment type, size, and minimum efficiency. (1.0 pt)

Residential Energy and Ventilation Compliance Summary, continued

<input type="checkbox"/> 5c (1.5 pts)	Efficient Water Heating 5c: Water heating system shall include one of the following: <u>gas, propane or oil</u> water heater with minimum EF of 0.91; OR <u>Electric heat pump</u> water heater with EF ≥ 2.0 per NEEA's Northern Climate specifications for Heat Pump Water Heaters; OR solar water heating supplementing standard water heater. Solar water heating will provide rated minimum savings of 85 therms or 2000 kWh based on Solar Rating and Certification Corp (SRCC) Annual Performance of OG-300 Certified Solar Water Heating Systems(provide savings calculations); specify water heating equipment type, size, and efficiency.				
<input type="checkbox"/> 5d (0.5 pt)	Efficient Water Heating 5d: Drain water heat recovery unit(s) installed on all shower waste water drains with minimum efficiency $\geq 40\%$ if installed for equal flow, OR minimum efficiency $\geq 52\%$ if installed for unequal flow. Rated per CSA B55.1 standard and so labeled. Must submit Plumbing diagram that specify water heat recovery units, and plumbing layout needed to install with documentation for compliance to standard.				
<input type="checkbox"/> 6 (0.5 - 3 pts)	Renewable Electric Energy: for each 1200 kWh of electrical generation per housing unit provided annually by on-site wind or solar equipment allows 0.5 pt credit up to 3 pts credits. Generation shall be calculated as follows: <table border="1" data-bbox="248 636 1533 835"> <tr> <td data-bbox="248 636 362 730">=</td> <td data-bbox="370 636 1533 730">Solar electric systems: design shall be demonstrated to meet requirement using the National Renewable Energy laboratory calculator PVWATTS. Solar access documentation to be included.</td> </tr> <tr> <td data-bbox="248 741 362 835">=</td> <td data-bbox="370 741 1533 835">Wind generation projects: design shall document annual power generation based on the following factors: wind turbine power curve, average annual wind speed at the site, frequency distribution of the wind speed at the site and the height of the tower.</td> </tr> </table>	=	Solar electric systems: design shall be demonstrated to meet requirement using the National Renewable Energy laboratory calculator PVWATTS. Solar access documentation to be included.	=	Wind generation projects: design shall document annual power generation based on the following factors: wind turbine power curve, average annual wind speed at the site, frequency distribution of the wind speed at the site and the height of the tower.
=	Solar electric systems: design shall be demonstrated to meet requirement using the National Renewable Energy laboratory calculator PVWATTS. Solar access documentation to be included.				
=	Wind generation projects: design shall document annual power generation based on the following factors: wind turbine power curve, average annual wind speed at the site, frequency distribution of the wind speed at the site and the height of the tower.				
<p>Must specify on the building plans the option being selected, and shall show the photovoltaic or wind turbine equipment type, provide documentation of solar or wind access, and include a calculation of the minimum annual energy powerproduction.</p>					

Washington State Energy Code requirements for Alterations to Existing Structures

- Unaltered portions of the existing building are not required to comply with the current Energy Code requirements. Remodels are exempt from Energy Credit Option Compliance
- All buildings and structures, and portions of shall be maintained in conformance with the Code edition when installed.
- Alterations shall be deemed in compliance where addition alone complies, where existing and alteration comply as single building, or where addition uses no more energy than existing unaltered building.
- Alterations shall be such that the existing building is no less conforming than it was before the alteration, and existing building with alteration does not use any more energy than the existing prior to the alteration.
- Conversion of non-conditioned space shall be treated as an addition and must comply as if new construction.
- Where wall cavities are exposed during construction, fill wall cavity to maximum extent possible: minimum R-15 batt insulation in 2x4 stud walls, R-21 in 2x6 stud walls.
- Where roof cavities are exposed during construction, fill rafter/ceiling cavity to R-38 or maximum extent possible and maintain 1" airspace above insulation for ventilation.
- Where floor framing cavities are exposed during construction, install R-30 insulation under exposed conditioned floor areas.
- All new windows and doors, and all relocated / reinstalled windows or doors shall have a weighted average U = 0.30
- All new mechanical equipment and system components shall comply with current Code provisions.
- When more than 50% of light fixtures are replaced, 75% of ALL LAMPS shall be high efficiency (LED or CFL).

Residential Energy and Ventilation Compliance Summary, continued

AIR BARRIER AND INSULATION INSTALLATION TABLE R402.4.1.1		
COMPONENT	AIR BARRIER CRITERIA ^d	INSULATION CRITERIA ^d
Air barrier and thermal barrier	A continuous air barrier shall be installed in the building envelope. Exterior thermal envelope contains a continuous air barrier. Breaks or joints in the air barrier shall be sealed.	Air-permeable insulation shall not be used as a sealing material. Class I or II vapor retarders are required on the interior side of framed cavities.
Cavity insulation installation	All cavities in the thermal envelope shall be filled with insulation. The density of the insulation shall be at the manufacturers' product recommendation and said density shall be maintained for all volume of each cavity. Batt type insulation will show no voids or gaps and maintain an even density for the entire cavity. Batt insulation shall be installed in the recommended cavity depth. Where an obstruction in the cavity due to services, blocking, bracing or other obstruction exists, the batt product will be cut to fit the remaining depth of the cavity. Where the batt is cut around obstructions, loose fill insulation shall be placed to fill any surface or concealed voids, and at the manufacturers' specified density. Where faced batt is used, the installation tabs must be stapled to the face of the stud. There shall be no compression to the batt at the edges of the cavity due to inset stapling installation tabs. Insulation that upon installation readily conforms to available space shall be installed filling the entire cavity and within the manufacturers' density recommendation.	
Ceiling/attic	The air barrier in any dropped ceiling/soffit shall be aligned with the insulation and any gaps in the air barrier sealed. Access openings, drop down stair or knee wall doors to unconditioned attic spaces shall be sealed.	Batt insulation installed in attic roof assemblies may be compressed at exterior wall lines to allow for required attic ventilation. The insulation in any dropped ceiling or soffit shall be aligned with the air barrier.
Walls	The junction of the foundation and sill plate shall be sealed. The junction of the top plate and top of exterior walls shall be sealed. Knee walls shall be sealed.	Cavities within corners and headers shall be insulated by completely filling the cavity with a material having a minimum thermal resistance of R-3 per inch. Exterior thermal envelope insulation for framed walls shall be installed in substantial contact and continuous alignment with the air barrier.
Windows, skylights and	Space between window/door jambs and framing and skylights and framing shall be sealed.	
Rim joists	Rim joists shall include the air barrier.	Rim joists shall be insulated
Floors (including above-garage and cantilevered)	The air barrier shall be installed at any exposed edge of insulation.	Installed to maintain permanent contact with underside of subfloor decking or permitted to be in contact with the topside of sheathing or continuous insulation installed on the underside of floor framing and extend from the bottom to the top of all perimeter floor
Crawl space walls	Soil in unvented crawl spaces shall be covered with Class I, black vapor retarder with joints taped.	Where provided in lieu of floor insulation, insulation shall be permanently attached to the crawlspace walls.
Shafts, penetrations	Duct shafts, utility penetrations, and flue shafts opening to exterior or unconditioned space shall be sealed.	
Narrow cavities		Batts in narrow cavities shall be cut to fit and installed to the correct density without any voids or gaps or compression. Narrow cavities shall be filled by insulation that on installation readily conforms to the available cavity space.
Garage separation	Air sealing shall be provided between the garage and conditioned spaces.	
Recessed lighting	Shall be sealed to the drywall.	Shall be air tight, and IC rated.
Plumbing and wiring		Batt insulation shall be cut neatly to fit around wiring and plumbing in exterior walls. There shall be no voids or gaps or compression where cut to fit. Insulation that readily conforms to available space shall extend behind piping and wiring.
Shower and/or tub	Installed at exterior walls adjacent to showers and tubs shall separate them from showers and tubs.	Exterior walls adjacent to showers or tubs shall be insulated
Electrical/phone	Barrier shall be installed behind electrical or communication boxes on exterior wall or install air sealed boxes.	
HVAC register boots	Boots that penetrate building thermal envelope shall be sealed to the subfloor or drywall.	
Concealed Sprinklers	When required to be sealed, fire sprinklers shall only be sealed in a manner that is recommended by the manufacturer. Caulking or other adhesive sealants shall not be used to fill voids between fire sprinkler cover plates and walls or ceilings.	

Residential Energy and Ventilation Compliance Summary, continued

VENTILATION AND INDOOR AIR QUALITY REQUIREMENTS

Whole House Ventilation fan(s) shall be sized according to International Residential Code section M1507.3.3.

* Continuously operating exhaust ventilation systems shall provide minimum flows per Table M1507.3.3(1).

* Intermittently operating ventilation systems shall have the minimum flows from Table M1507.3.3(1) adjusted by the ventilation rate multiplier value in Table M1507.3.3(2) according to the formula $Q_f = Q_r \times E_f$

**2015 International Residential Code Table M1507.3.3(1)
Minimum Ventilation Rates For Dwellings Four Stories Or Less, Q_r**

Floor Area	Number of Bedrooms								
	0	1	2	3	4	5	6	7	>7
0 to 1500	30	30	45	45	60	60	75	75	90
1501 to 3000	45	45	60	60	75	75	90	90	105
3001 to 4500	60	60	75	75	90	90	105	105	120
4501 to 6000	75	75	75	90	90	105	105	120	135
6001 to 7500	90	90	90	105	105	120	135	135	150
>7500	105	105	120	120	135	135	150	150	165

2015 International Residential Code Table M1507.3.3(2)

INTERMITTENT WHOLE-HOUSE VENTILATION RATE FACTORS (E_f)

Run-time % in each 4-hour segment	Rate Multiplier Factor	Min. Fan Size (cfm)	Specified Fan Size
25% (1 hr every 4 hrs; 6 hrs /day)	4		
33% (1 hr 20 min every 4 hrs; 8 hrs /day)	3		
50% (2 hrs every 4 hrs; 12 hrs /day)	2		
66% (2 hrs 40 min every 4 hrs; 16 hrs /day)	1.5		
75% (3 hrs every 4 hrs; 18 hrs /day)	1.3		
100% (continuously operating)	1.0		

Whole house exhaust fan shall have a maximum sone rating of 1.0, or install in-line duct fan located a minimum 48 inches from intake grille opening.

MAXIMUM AIR LEAKAGE

Components of the building thermal envelope as listed in TABLE R402.4.1.1 shall be installed per manufacturer's specifications to limit air leakage rate to not exceed **5 air changes per hour**.

(Energy Credit Options 2 limits max ACH, refer to Energy Credit Option Table above)

Blower door test @50 Pa max. rate: (Bldg Vol (ft³) _____ x 5 ACH) / 60 min. = _____ cfm

WHOLE HOUSE VENTILATION SYSTEM

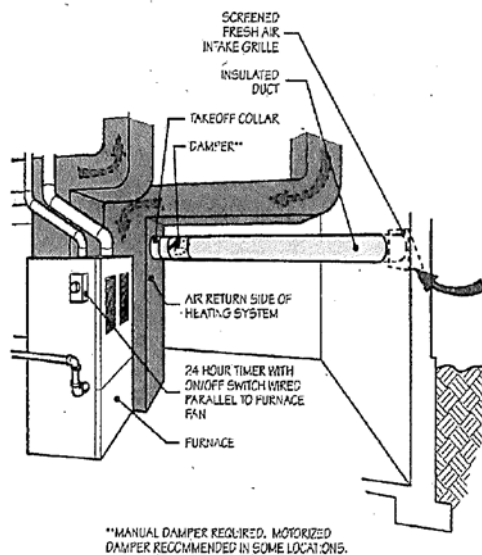
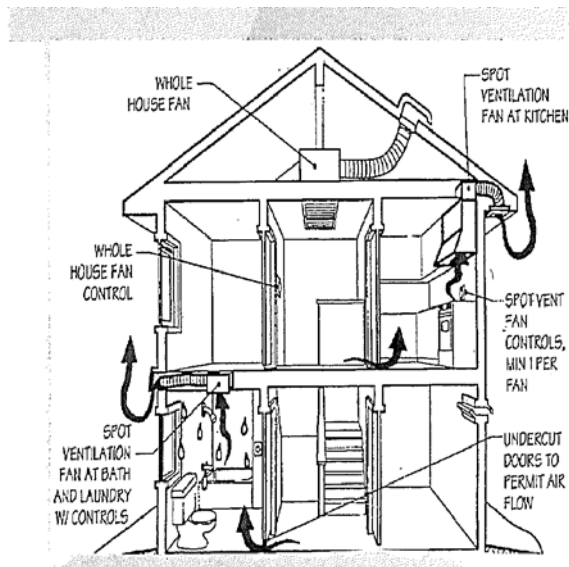

M1507.3.4 Exhaust Fan System

M1507.3.5 Integrated System with Furnace

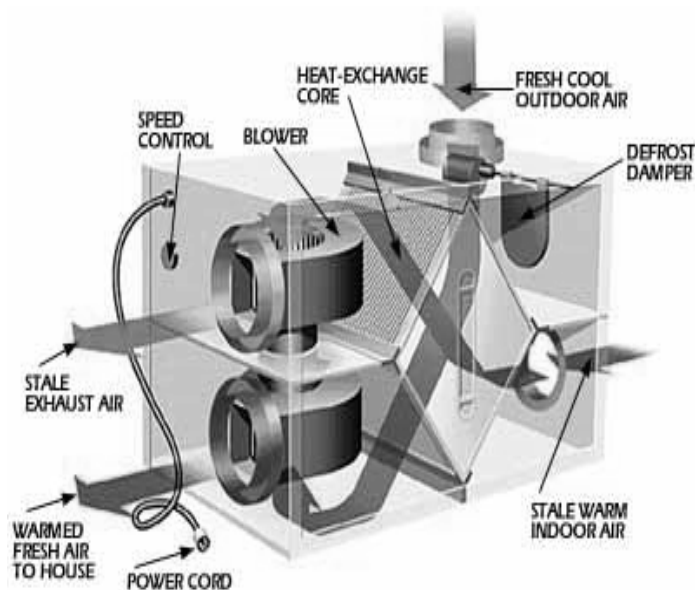
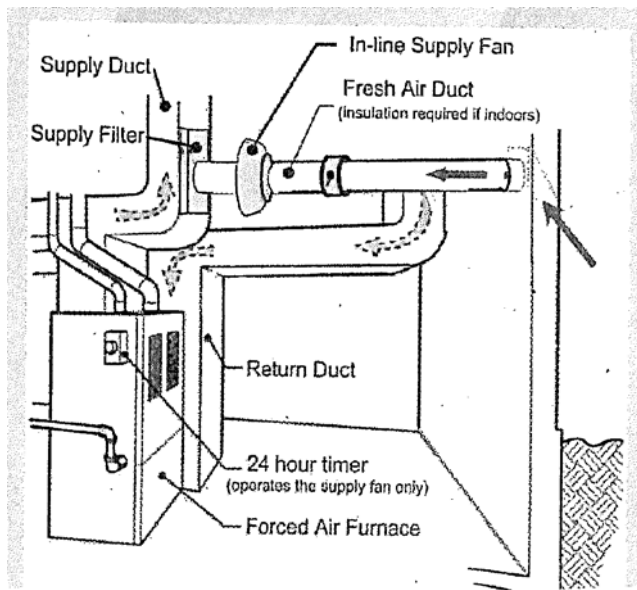

M1507.3.6 Supply Fan System

M1507.3.7 Heat Recovery System

Residential Energy and Ventilation Compliance Summary, continued

Building Heat Loss Calculation / U-factor Equivalent Compliance

Use common U-values from Appendix A, WAC chapter 51-11C or ASHRAE Handbook of Fundamentals
 Multiply component's area by U-value. Compliance achieved if Proposed is less than Code Allowable.

	Proposed components					CODE ALLOWABLE		
	Insulation Value	U-Value	Area	U*A=		U-Value	Area	U*A=
Attic Area					Opening area entered as 15% of total floor area ====>	0.027		
Vaulted Roof Area						0.026		
Existing Attic Area								
Existing Vaulted Roof Area								
Skylights						0.500		
New Windows / Doors						0.300		
Existing Windows / Doors								
Exterior Wall Area (net area)						0.056		
Existing Wall Area (net area)								
Floor Area over unheated area						0.029		
Existing Floor over unheated area								
Slab on Grade linear feet			ft.			0.54		
Existing Slab on Grade linear feet			ft.					
Below Grade Walls (net area)						0.042		
Existing Below Grade Walls								
				Total UA heat loss:		TOTAL heat loss allowed:		
				Energy credit option reduction				
					Opt.1a	5%		
					Opt.1b	15%		
					Opt.1c	30%		

Residential Energy and Ventilation Compliance Summary, continued

RESIDENTIAL SIMPLE HEAT SYSTEM SIZING ESTIMATION

Heating and cooling systems shall be sized in accordance with ACCA Manual S or equivalent.

Indoor Design temperature	70	City:	
Outdoor Design Temperature			
Design Temperature Difference:			
Total Conditioned Area (sq.ft.)		Average floor height	
Conditioned Volume (CV) =			
Total UA heat loss of proposed =			
Envelope Heat Load		Btuh	KW
(Total UA x Design Temp. difference)	Divide Btuh by 3413 to convert to KW		
Air Leakage Heat Load		Btuh	KW
(CV x 0.6 x Design Temp. Difference x 0.018)			
Building Design Heat Load		Btuh	KW
(Air Leakage Load + Envelope Heat Load)			
Building and Duct Heat Load		Btuh	KW
(Increase Building Design Heat Load by 10% if ducts located in unconditioned space)			
Maximum Heating Equipment Output		Btuh	KW
(40% increase allowed for Forced Air Furnace; 25% increase allowed for Heat Pump Systems)			

Actual heat sizing calculation for unit(s) installed to be supplied by mechanical contractor at the time of equipment installation.

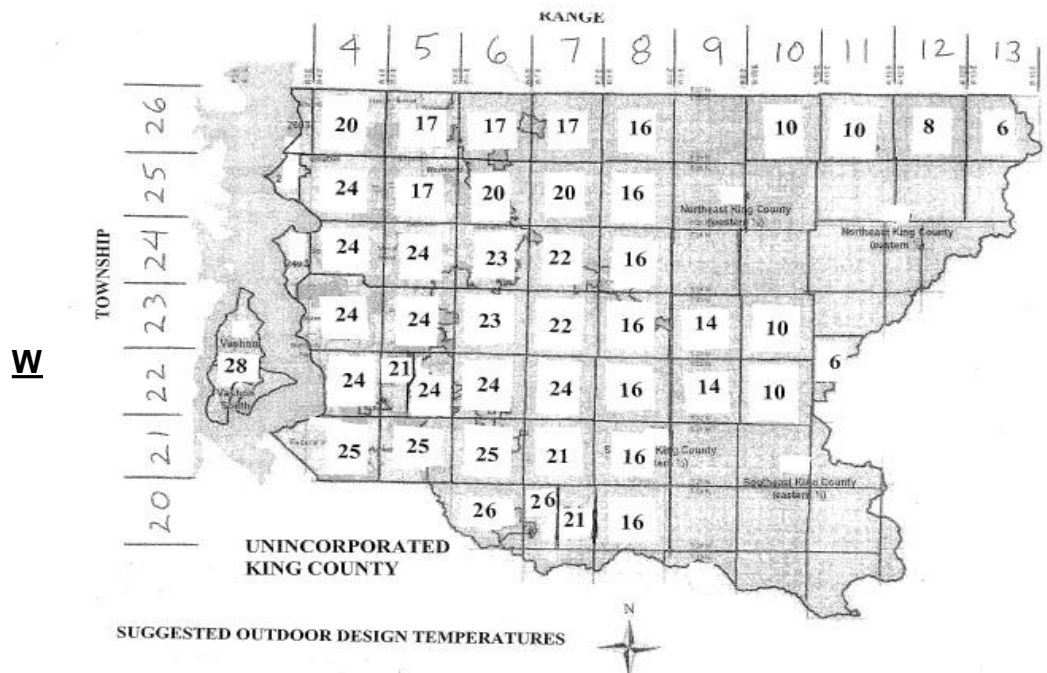

Residential Energy and Ventilation Compliance Summary, continued

Common U-Values for various framed elements

Ceilings / Attics		Framing type			Floors						
TYPE	Insulation	Standard	Intermed	Advance		Insulation	Beams	Joists			
FLAT	R-19	0.049		0.047		None	0.112	0.134			
	R-30	0.036		0.032		R-11	0.052	0.056			
	R-38	0.031		0.026		R-19	0.038	0.041			
	R-49	0.027		0.20		R-22	0.034	0.037			
	R-60	0.025		0.017		R-25	0.032	0.034			
Scissor Truss						R-30	0.028	0.029			
4:12	R-30	0.043		0.031		R-38	0.024	0.025			
4:12	R-38	0.040		0.025	SLAB ON GRADE	Slab perimeter insulated					
4:12	R-49	0.030		0.020	Uninsulated R-0	0.73					
5:12	R-30	0.039		0.032		2 ft. vert/horiz	4 ft vert/horiz				
5:12	R-38	0.035		0.026		R-5	0.58	0.54			
5:12	R-49	0.032		0.020		R-10	0.54	0.48			
VAULTED		16" OC	24" OC	24" OC		R-15	0.52	0.45			
2x10	R-19	0.049	0.048	0.049	FULLY INSULATED	Unheated	Heated	Slab			
2x12	R-30	0.034	0.033	0.033		R-0	0.73	0.84			
2x14	R-38	0.027	0.027	0.027		R-5	0.43	0.74			
2x10 unvent	R-30	0.034	0.033	0.033		R-10	0.36	0.55			
2x12 unvent	R-38	0.029	0.027	0.027		R-15	0.31	0.44			
						R-20	0.26	0.39			
WALLS		Framing type			BELOW GRADE WALLS			Wall	Slab		
Lapped Wood Siding		Standard	Intermed	Advance	Depth below grade			U-value	F-factor		
2x4 wood	R-11	0.088	0.086	0.084	2 ft.	Uninsulated		0.35	0.59		
	R-13	0.082	0.080	0.078		Below	R-11 interior		0.066	0.68	
	R-15	0.076	0.073	0.071			R-11 int / thermal brk		0.070	0.60	
2x6	R-19	0.062	0.058	0.056			R-21 interior		0.043	0.69	
	R-21	0.057	0.054	0.051			R-21 int / thermal brk		0.045	0.61	
	R-22	0.059	0.055	0.052			R-10 exterior		0.070	0.60	
	(2) R-11	0.060	0.057	0.054	R-12 exterior			0.061	0.60		
2x8	R-25	0.051	0.047	0.045	3.5 ft.	Uninsulated		0.278	0.53		
T1-11 Wood Siding						below	R-11 interior		0.062	0.63	
2x4	R-11	0.094	0.092	0.090			R-11 int / thermal brk		0.064	0.57	
	R-13	0.088	0.085	0.0863			R-21 interior		0.041	0.64	
	R-15	0.081	0.078	0.075			R-21 int / thermal brk		0.042	0.57	
2x6	R-19	0.065	0.061	0.058			R-10 exterior		0.064	0.57	
	R-21	0.060	0.056	0.053	R-12 exterior			0.057	0.57		
	R-22	0.062	0.058	0.054	7 ft.	Uninsulated		0.193	0.46		
	(2) R-11	0.063	0.059	0.056		below	R-11 interior		0.054	0.56	
2x8	R-25	0.053	0.049	0.046			R-11 int / thermal brk		0.056	0.42	
Metal	16" oc	24" oc		16" oc			24" oc	R-21 interior		0.037	0.57
R-11	0.132		R-19	0.109			0.094	R-21 int / thermal brk		0.038	0.43
R-13	0.124		R-21	0.106			0.090	R-10 exterior		0.056	0.42
R-15	0.118		R-25	0.080	0.091		R-12 exterior		0.050	0.12	